



ON-LINE FUNDAMENTAL FREQUENCY TRACKING METHOD FOR HARMONIC SIGNAL AND APPLICATION TO ANC

S. KIM AND Y. PARK

*Department of Mechanical Engineering, Center for Noise and Vibration control,
Korea Advanced Institute of Science and Technology, Science Town, Taejeon 305-701,
South Korea. E-mail: yjpark@sorak.kaist.ac.kr*

(Received 23 December 1999, and in final form 28 August 2000)

In this paper, a new indirect feedback active noise control (ANC) scheme based on the fundamental frequency estimation is proposed for systems with a harmonic noise. When reference signals necessary for feedforward ANC configuration are difficult to obtain, the conventional ANC algorithms for multi-tonal noise do not measure the reference signals but generate them with the estimated frequencies [1]. However, the beating phenomena, in which certain frequency components of the noise vanish intermittently, may make the adaptive frequency estimation difficult. The confusion in the estimated frequencies due to the beating phenomena makes the generated reference signals worthless. The proposed algorithm consists of two parts. The first part is a reference generator using the fundamental frequency estimation and the second one is the conventional feedforward control. We propose the fundamental frequency estimation algorithm using decision rules, which is insensitive to the beating phenomena. In addition, the proposed fundamental frequency estimation algorithm has good tracking capability and lower variance of frequency estimation error than that of the conventional cascade ANF method. We are also able to control all interested modes of the noise, even which cannot be estimated by the conventional frequency estimation method because of the poor *S/N* ratio. We verify the performance of the proposed ANC method through simulations for the measured cabin noise of a passenger ship and the measured time-varying engine booming noise of a passenger vehicle.

© 2001 Academic Press

1. INTRODUCTION

An effort to cancel the noise by superposing a sound with the opposite phase of the noise, which is called the active noise control (ANC), has been widely studied. ANC is very effective especially against low-frequency noise below 500 Hz, which is hard to reduce by passive means. For active control of sound and vibration, two types of control strategy have been widely applied. The first one is a feedforward control method, which requires both a reference signal and an error signal. This method attenuates broadband noise as well as narrowband one. The measured reference signal, which is correlated with the impending primary noise, is used so as to derive the control input. If the correlation between the reference and the error signal is perfect, it is theoretically possible to make the error signal zero, which is very attractive feature. However, if there is only the partial correlation, the system only cancels the primary noise components that are correlated with the reference signal. Because of its high stability and performance robustness, it has been used in many applications [2]. The second one is a feedback control method, which requires the error

signal alone to attenuate periodic noise. There are systems with difficulty in obtaining suitable references or active control systems characterized by a narrowband disturbance. These systems typically use feedback control in order to avoid the problems associated with obtaining a reference signal for use in a feedforward LMS configuration. It is well known that a certain level of noise reduction can only be achieved over a limited bandwidth. For this method, the smaller the error signal is driven, the higher the control gain must be, and the less stable will be the system [3].

Active control of the harmonic noise has received a great deal of attention because rotating or reciprocating machinery such as engines or fans induces the harmonic noise [1, 4]. As mentioned above, we can obtain good performance for the harmonic noise using a feedforward control method only when a reference is available. ANC with reference generator, which estimates the frequencies of the period noise, has been studied when a reference is not available. Typical example is active control of an exhaust engine noise in the cabin of a passenger ship [1].

In this paper, a new indirect feedback ANC algorithm is proposed for the harmonic noise. Firstly, we estimate the fundamental frequency of the noise signal in the controlled field. Secondly, we generate the harmonic signal with the estimated fundamental frequency and use it as reference signal in the conventional feedforward ANC configuration. If the fundamental frequency of the noise is exactly estimated, the scheme will be identical to the conventional normalized feedforward method that measures harmonics directly, except that the smaller order of the adaptive controller may be used because the reference signal of the proposed method has no measurement noise.

Consider the noise signal with the beating phenomena. The closer two beating frequencies get, the longer the vanishing duration becomes. In this case, certain harmonic components vanish and reappear repeatedly and it causes drift in the estimated frequencies. Therefore, the conventional frequency estimation methods might not estimate the frequencies of the noise during the vanishing periods.

We propose a new fundamental frequency estimation algorithm for harmonic noise with the beating phenomena. Decision rules based on harmonic constraints filter out the erroneous estimation caused by the beating phenomena. Then, we estimate the fundamental frequency with only well-estimated components of the noise. Therefore, we can avoid the effect of the beating phenomena and keep the tracking capability of frequency estimation intact. In order to verify the feasibility of the proposed method we simulate the proposed method for the measured cabin noise of a passenger ship and time-varying engine booming noise of a vehicle.

2. ON-LINE FUNDAMENTAL FREQUENCY TRACKING METHOD

2.1. FREQUENCY ESTIMATION METHOD BASED ON THE CASCADE ADAPTIVE NOTCH FILTER

The problem of estimating the frequencies of multiple sinusoids buried in noise has received considerable attention of researchers in the field of signal processing [1, 5]. The frequency estimation method using the cascade adaptive notch filter (ANF) has superior performance for harmonic noise in terms of computational efficiency, convergence rate and threshold SNR [1]. Notations of this paper follow those of reference [1].

Figure 1 shows the block diagram of the frequency estimation method based on the cascade ANF. The cascade ANF is composed of p notch filters of order 2 in series to estimate p frequencies of p sinusoids. When we adapt each notch filter to minimize the squared error of each section, the central notch frequencies of the notch filters become the frequencies of the sinusoidal signal $x(n)$.

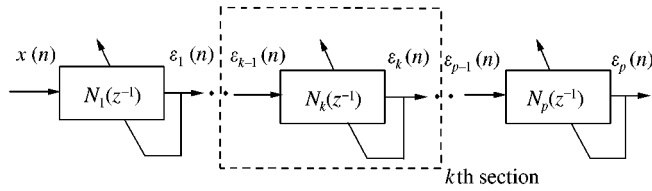

Figure 1. Block diagram of the cascade ANF method.

Equation (1) shows the transfer function of the notch filter with constrained poles and zeros, where q^{-1} indicates one-step delay operator. Tuning variable ρ , called a pole contraction factor, is a positive real number close to but smaller than 1 and is related to the bandwidth of the notch

$$\begin{aligned} \varepsilon_k(n) &= N_k(q^{-1})\varepsilon_{k-1}(n) = \frac{A_k(q^{-1})}{A_k(\rho q^{-1})} \varepsilon_{k-1}(n), \\ &= \frac{1 + a_k(n)q^{-1} + q^{-2}}{1 + \rho a_k(n)q^{-1} + \rho^2 q^{-2}} \varepsilon_{k-1}(n), \quad k = 1, 2, \dots, p. \end{aligned} \tag{1}$$

We adapt the parameter $a_k(n)$ of the notch filters by the linearized minimal parameter estimation method based on recursive least-squares method [1]. The adaptation algorithm is derived as follows:

$$\tilde{\varepsilon}_k(n) \equiv \frac{1}{A_k(\rho q^{-1})} \varepsilon_{k-1}(n) = \varepsilon_{k-1}(n) - \rho a_k(n-1)\tilde{\varepsilon}_k(n-1) - \rho^2 \tilde{\varepsilon}_k(n-2), \tag{2}$$

$$\Phi_k(n) = \lambda \Phi_k(n-1) + \tilde{\varepsilon}_k(n-1)^2, \tag{3}$$

$$z_k(n) = \lambda z_k(n-1) + \tilde{\varepsilon}_k(n-1) \{ \tilde{\varepsilon}_k(n) + \tilde{\varepsilon}_k(n-2) \}, \tag{4}$$

$$a_k(n) = -\Phi_k(n)^{-1} z_k(n), \quad k = 1, 2, \dots, p, \tag{5}$$

where λ is a forgetting factors.

Each sections is adapted by equations (2)–(5) sequentially. The frequencies of the sinusoidal signal $x(n)$ are obtained from the central notch frequencies calculated as follows:

$$\hat{f}_k(n) = \frac{1}{2\pi} \cos^{-1} \left(-\frac{a_k(n)}{2} \right), \quad k = 1, 2, \dots, p. \tag{6}$$

Figures 2 and 3 show the steady state power spectrum and the periodogram of the noisy harmonic signal, respectively.

We estimated the tonal frequencies of the noisy signal measured in the cabin of a passenger ship with constant speed to obtain more realistic results. According to the spectrum analysis of the signal, higher order harmonics in range of 70–160 Hz are dominant. Moreover, we observed the beating phenomean according to the spectrum analysis with very high resolution in Figure 2 and the vanishing harmonic components intermittently as shown in Figure 3, time–frequency plot. Even after the complete convergence, the frequency estimation was confused during the vanishing duration as shown in Figures 3 and 4. Figure 4 shows the frequency estimation results of the signal by the cascade ANF method.

We propose the fundamental frequency estimation method in the next section, which is able to avoid the drifting effect caused by the beating phenomena.

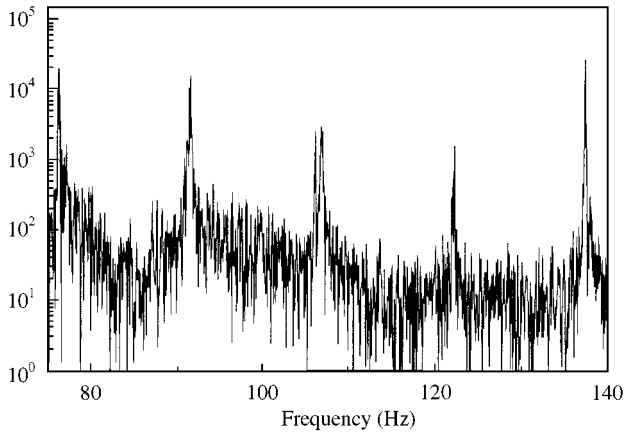

Figure 2. Spectrum with high resolution.

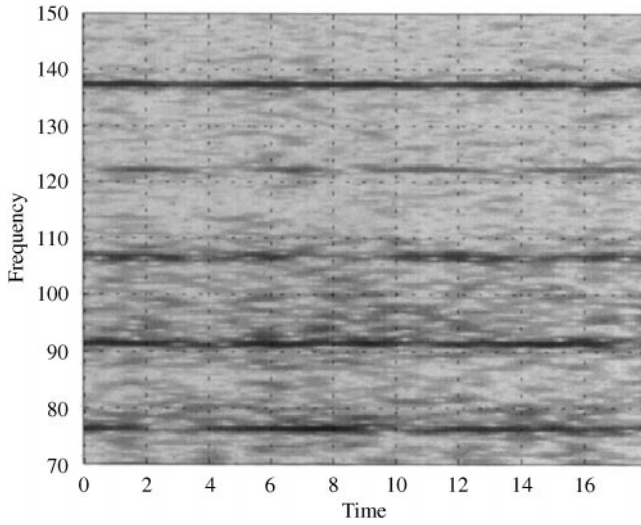

Figure 3. Periodogram of cabin noise of a passenger ship

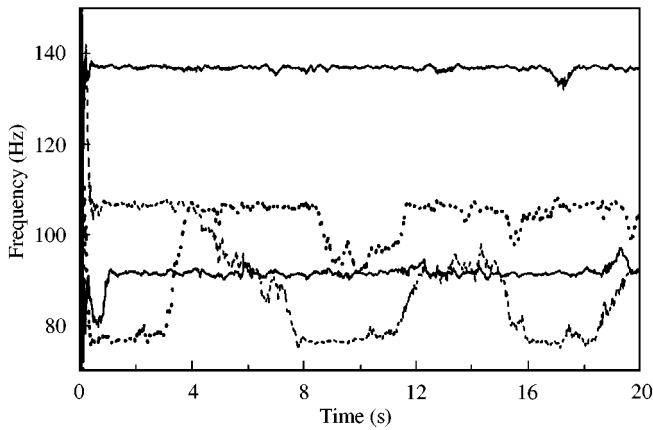

Figure 4. Estimated frequencies confused due to beating phenomena: (—, f_1 ; — —, f_2 ; ····, f_3 ; - · - ·, f_4).

2.2. DECISION RULES USING HARMONIC CONSTRAINTS

In general, rotating or reciprocating machinery such as engines or fans induces the harmonic noise. We propose the fundamental frequency estimation method for the harmonic noise. Firstly, we estimate the frequencies of the harmonic signal by the cascade ANF method. Secondly, we filter out the effect of drifting components among the estimated frequencies caused by the beating phenomena by using the decision rules. Thirdly, we estimate the fundamental frequency of the harmonic signal with only well-estimated frequencies. We assume that it is previously known which order harmonics are dominant and the orders of the dominant modes are time-invariant. Note that it does not mean the fundamental frequency is time-invariant. The schematic diagram of the frequency estimation method with decision rules is shown in Figure 5.

Decision rules use harmonic constraints, which are obtained from the mode order assumption. The fundamental frequency is obtained by dividing each estimated frequency with its previously known mode order. We construct decision rules as follows. (1) Confirm the convergence of the frequency estimation by checking whether all the estimation values are in allowable variance. (The next step is conducted after convergence). (2) Sort the estimated frequencies. (3) Calculate p fundamental frequencies $\Delta \hat{f}_k(n)$ from p notch filters as follows:

$$\Delta \hat{f}_k(n) = \frac{\hat{f}_k(n)}{m_k}, \quad m_k = \text{mode order}, \quad k = 1, 2, \dots, p. \quad (7)$$

(4) Check whether each of calculated fundamental frequencies is inside a tolerance bound. (5) Estimate the fundamental frequency through averaging the fundamental frequencies inside the tolerance bound as follows:

$$\Delta f(n) = \frac{1}{p_1} \sum_{k=1}^{p_1} \Delta \hat{f}_k(n), \quad (8)$$

where p_1 is the number of the well-estimated fundamental frequencies.

Note that variance of the estimation error can be reduced due to the averaging effect. This property is derived in Appendix A. See also Appendix B for the convergence checking algorithm.

2.3. FUNDAMENTAL FREQUENCY TRACKING

As mentioned in the above section, we estimate the fundamental frequency by averaging the fundamental frequencies selected by the decision rules. The proposed method is not

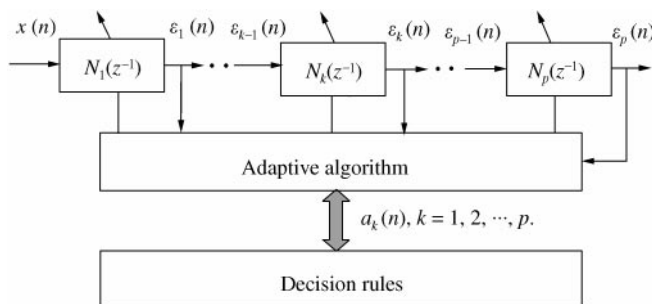

Figure 5. The schematic diagram of the frequency estimation method with decision rules.

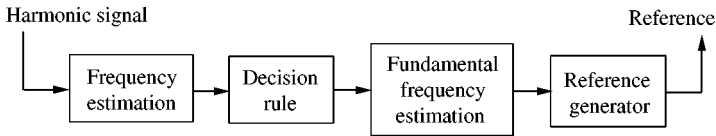

Figure 6. The schematic diagram of the reference generation method.

affected by the drifting effect caused by the beating phenomena because the decision rules filter out the erroneous frequency estimation components. Moreover, the method is able to keep the fast tracking capability of the cascade ANF method intact [1].

The reference generation part and how to use it for a feedforward ANC configuration will be mentioned in the next section. Figure 6 shows the schematic diagram of the reference generation method.

3. ACTIVE CONTROL OF HARMONIC NOISE

3.1. REFERENCE GENERATION FOR FEEDFORWARD ANC

We generate the reference signal for feedforward ANC configuration by using the fundamental frequency and known mode order. The conventional ANC method with reference generator based on the frequency estimation [1] generates the reference signal from the estimated frequencies. Therefore, disturbance components, which cannot be estimated by the frequency estimation method, cannot be used as reference. However, the proposed method generates the reference signal, which includes all frequency components of the disturbance noise. The reference signal $r(n)$ is generated as follows:

$$r(n) = \sum_{k=1}^l \sin\left(2\pi \sum_{i=0}^n f_k(i)\right), \quad (9)$$

where l is the number of the modes of the interested disturbance noise. In equation (9), the frequency $f_k(n)$ is as follows:

$$f_k(n) = m_{a,k} \times \Delta f(n). \quad (10)$$

where $k = 1, 2, \dots, l$, and $m_{a,k}$ is the mode order of the frequency whose magnitude should be reduced.

3.2. ANC WITH REFERENCE GENERATOR

It is necessary to estimate the disturbance signal from the error signal so as to estimate the fundamental frequency of the disturbance noise. We use the internal model control (IMC) technique to estimate the disturbance signal [1, 6]. Figure 7 shows the block diagram of ANC with reference generator.

In Figure 7, the $\mathbf{W}(z)$, the $\mathbf{H}(z)$, and the $\hat{\mathbf{H}}(z)$ are a controller filter, a cancellation path, and a model of the cancellation path, respectively. Reference generator is the block of the proposed approach mentioned in section 2. The $d(n)$ and the $\hat{d}(n)$ are a disturbance noise and an estimate of $d(n)$, respectively. The lower part of the block diagram is equivalent to a block diagram of the *filtered-x* LMS algorithm [7]. The upper part of the block diagram consists of both the part to estimate $d(n)$ and the part to estimate the fundamental frequency of $\hat{d}(n)$ and to generate the reference signal. The estimate of the disturbance noise, $\hat{d}(n)$, is

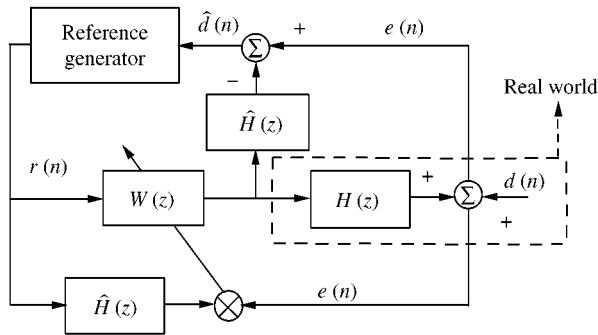

Figure 7. Block diagram of ANC with reference generator.

obtained as follows:

$$\hat{d}(n) = e(n) - \hat{H}(q^{-1})W(q^{-1})r(n). \quad (11)$$

If the model of the cancellation path is exact, $\hat{d}(n)$ is equal to $d(n)$ and it becomes the harmonic input of the reference generator. Therefore, we firstly estimate the disturbance noise using equation (11). Secondly, we estimate the fundamental frequency of the estimated disturbance noise using equations (1)–(8) and generate the reference signal using equations (9) and (10). Finally, it is used as the reference of the conventional *filtered-x* LMS algorithm. In order to improve performance of the proposed method, we use a band-pass filter with a proper bandwidth in front of the harmonic input.

4. SIMULATION RESULTS

We simulated the proposed method for both the measured cabin noise of the passenger ship to verify its performance and the measured time-varying engine booming noise of the vehicle to verify the tracking capability. We used a constrained *filtered-x* LMS algorithm [8] as the feedforward control algorithm. In this simulation, we assumed that we know the exact model of the cancellation path.

For the case of knowing the exact model, the stability of the similar ANC algorithm is considered in reference by Kim and Park [1]. Even though $\hat{\mathbf{H}}(z)$ is not identical to $\mathbf{H}(z)$ as long as $\mathbf{H}(z)$ is time invariant and the disturbance noise is quasi-stationary, the fundamental frequency of the true disturbance noise is equal to that of the estimated disturbance noise. Therefore, if $\mathbf{H}(z)$ is time invariant and the disturbance noise is quasi-stationary, the disagreement of $\hat{\mathbf{H}}(z)$ and $\mathbf{H}(z)$ does not have major influence on the stability of the proposed reference generation algorithm.

Figure 8 shows the steady state power spectra of the cabin noise of a passenger ship before and after control. The periodogram of the noise is shown in Figure 3. The step size of controller update was 0.04 and the tap of the controller filter was 70. As shown in Figure 8, five frequency components were reduced by about 10–20 dB. In the simulations, we used the cancellation path H obtained from the experiment in reference [1]. Figure 9 shows the cancellation path with 48 FIR taps.

Figure 10 shows the frequencies of the generated reference signal. Because the number of the dominant frequency components in range of the interested bandwidth 70–160 Hz is four, we estimated four frequencies ($p = 4$) and the fundamental frequency from them, and generated the reference signal which includes five frequency components ($l = 5$) to be

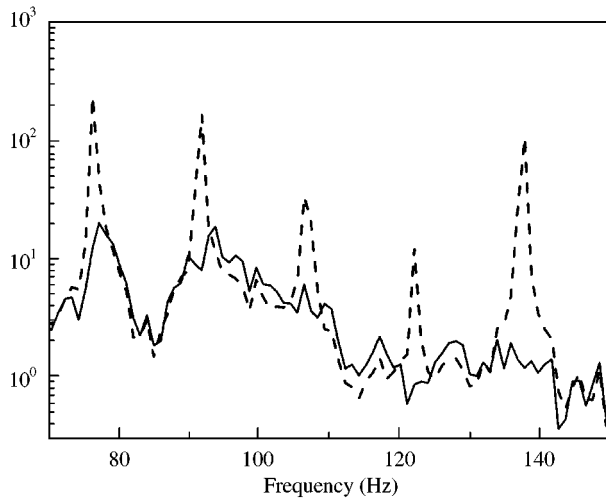

Figure 8. Power spectra of the cabin noise of a passenger ship before and after control: ---, before control; —, after control.

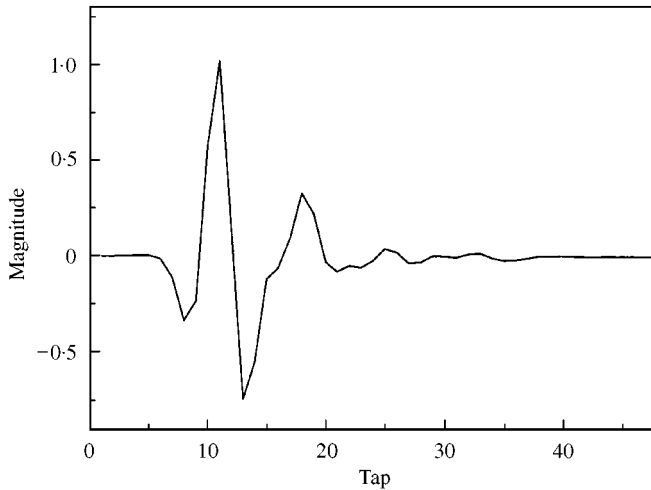

Figure 9. The cancellation path resulted from experiment: —, cancellation path.

reduced. The estimated fundamental frequency was 15.3 Hz and the mode order was $m_k = [5, 6, 7, 9]$ and $m_{a,k} = [5, 6, 7, 8, 9]$. The frequency estimation was converged after 2850 step. The forgetting factor and the pole contraction factor were updated as follows:

$$\rho(n + 1) = 0.99\rho(n) + (1 - 0.99)0.99 \quad \text{and} \quad \lambda(n + 1) = 0.99\lambda(n) + (1 - 0.99)0.99, \quad (12)$$

where both initial values were 0.85. As shown in Figure 10, the proposed method was not affected by the beating phenomena, and the fundamental frequency was estimated properly.

Figure 11(a) and 11(b) show the waterfall of the measured engine booming noise before and after control, respectively. The step size of controller update was 0.3 and the tap of the adaptive filter was 50. The cancellation path H was modelled by an FIR filter with six-step delay, i.e., $[0, 0, 0, 0, 0, 4, -3, 1, 0.5, 0.1]$. It is assumed that the cancellation path is exact. As shown in Figure 11(a) and 11(b), nine frequency components were reduced by about 5–15 dB.

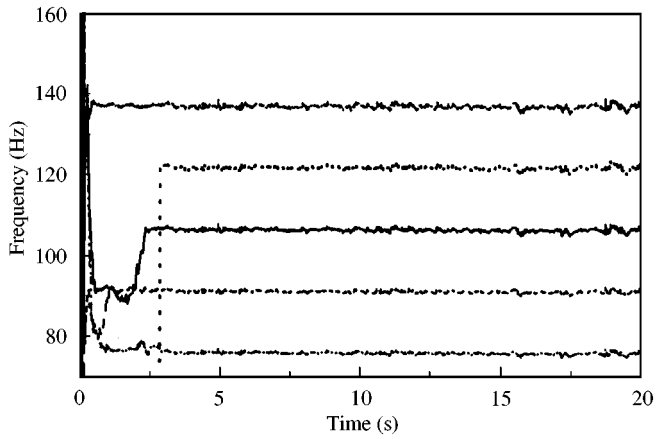

Figure 10. Frequencies of the generated reference signal: \dashdotdash , f_1 ; $---$, f_2 ; $—$, f_3 ; \dashdot , f_4 ; \dots , f_5 .

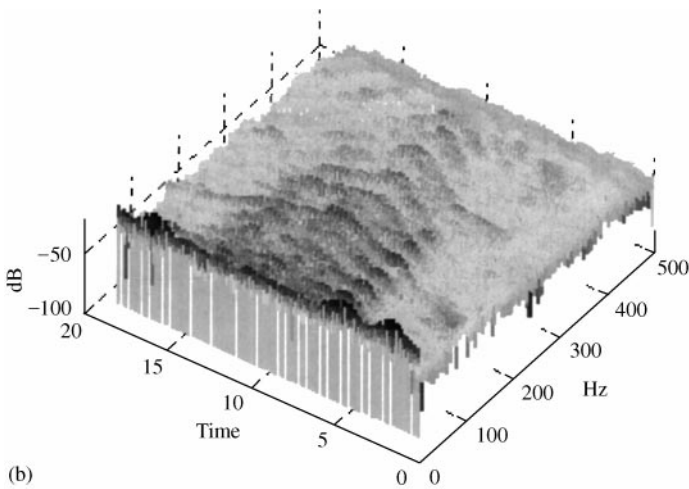
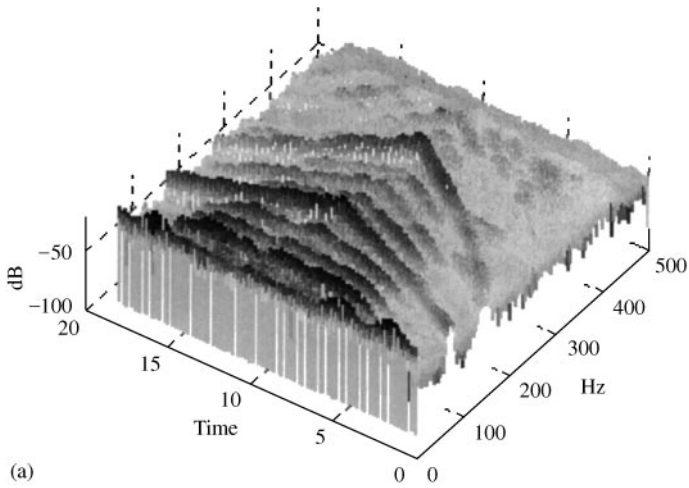

Figure 11. Waterfall of the engine booming noise (a) before control; (b) after control.

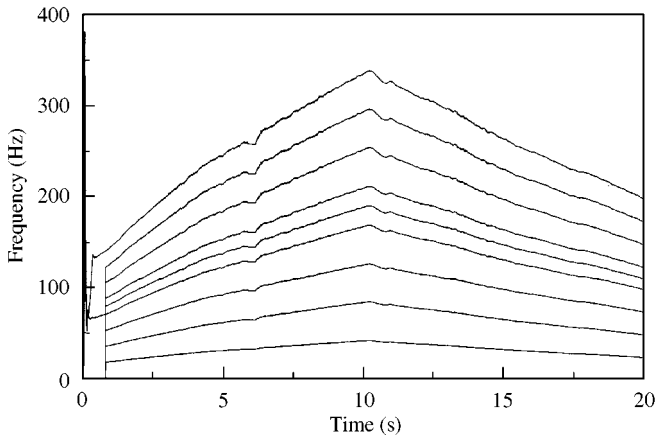

Figure 12. Frequencies of the generated reference signal.

Figure 12 shows the frequencies of the generated reference signal. Because the number of the dominant frequency components in range of the bandwidth 10–450 Hz is 2, we estimated two frequencies ($p = 2$) and the fundamental frequency from them, and generated the reference signal which included nine frequency components ($l = 9$) to be reduced. The mode order was $m_k = [4, 8]$ and $m_{a,k} = [1, 2, 3, 4, 4.5, 5, 6, 7, 8]$. The frequency estimation converged after 820 steps. The forgetting factor and the pole contraction factor were updated as follows:

$$\rho(n+1) = 0.99\rho(n) + (1 - 0.99)0.98 \quad \text{and} \quad \lambda(n+1) = 0.99\lambda(n) + (1 - 0.99)0.98, \quad (13)$$

where both initial values were 0.85. As shown in Figure 12, the proposed method has good tracking capability.

5. CONCLUSIONS

We proposed an ANC scheme based on the fundamental frequency estimation for harmonic noise reduction. The proposed algorithm is composed of two parts. The first part is a reference generator using the estimated fundamental frequency, and the second one is the conventional feedforward control. The proposed indirect feedback ANC algorithm generates the reference signals, and embodies the feedforward configuration using them. We can obtain better performance than the conventional feedback ANC algorithm.

The proposed fundamental frequency estimation method using the decision rules was not influenced by the beating phenomena. In addition, it has good tracking capability and lower variance of frequency estimation error than that of the conventional cascade ANF method. We were also able to control every interested mode of the harmonic noise. We verified performance of the proposed ANC method through simulations for the measured cabin noise of a passenger ship and the measured time-varying engine booming noise of a vehicle.

REFERENCES

1. S. KIM and Y. PARK 1999 *Journal of Sound and Vibration* **227**, 647–666. Active control of multi-tonal noise with reference generator based on on-line frequency estimation.

2. C. H. HANSEN and S. D. SNYDER 1997 *Active Control of Noise and Vibration*, 374–543. London: E & FN SPON.
3. S. M. KUO and D. VIJAYAN 1994 *Noise Control Engineering* **42**, 37–46. Adaptive algorithm experimental verification of feedback active noise control systems.
4. T. USAGAWA, Y. SHIMADA and M. EBATA 1998 *INTERNOISE'98*, Adaptive algorithm for active control of periodic noise with on-line frequency tracking.
5. S. M. KAY and S. L. MARPLE 1981 *Proceedings of the IEEE* **69**, 1380–1419. Spectrum analysis—a modern perspective.
6. S. E. FORSYTHE, M. D. MCCOLLUM and A. D. MCCLEARY 1991 *Proceedings of Advances in Active Control of Sound and Vibration*, 879–889. Stabilization of a digitally controlled active isolation system.
7. J. C. BURGESS 1981 *Journal of the Acoustical Society of America* **70**, 715–725. Active adaptive sound control in a duct: a computer simulation.
8. I.-S. KIM, H.-S. NA, K.-J. KIM and Y. PARK 1994 *Journal of the Acoustical Society of America* **95**, 3376–3389. Constraint filtered-x and filtered-u least mean square algorithms for the active control of noise in ducts.

APPENDIX A: DECREASE OF VARIANCE BY AVERAGING EFFECT

Consider p_1 statistically independent random processes and their summed process as follows:

$$x_i(\mu_i, \sigma_i^2), \quad i = 1, 2, \dots, p_1 \quad \text{and} \quad x_s = \frac{1}{p_1} \sum_{i=1}^{p_1} x_i. \quad (\text{A1})$$

Then, the following properties are valid through simple derivation:

$$\mu_s = E[x_s] = \frac{1}{p_1} \sum_{i=1}^{p_1} \mu_i, \quad (\text{A2})$$

$$\sigma_s^2 = E[(x_s - \mu_s)^2] = \frac{1}{p_1} \left(\frac{1}{p_1} \sum_{i=1}^{p_1} \sigma_i^2 \right). \quad (\text{A3})$$

Variance of the summed signal theoretically decrease by about p_1 times compared with original signals.

APPENDIX B: CONVERGENCE CHECK ALGORITHM

$$\begin{aligned} \mu_{a,k}(n) &= s\mu_{a,k}(n-1) + (1-s)a_k(n), \\ \sigma_k(n) &= s\sigma_k(n-1) + (1-s)a_k(n)^2, \\ \text{var}_{a,k}(n) &= \sigma_k(n) - \mu_{a,k}(n)^2, \end{aligned} \quad (\text{B1})$$

if $(\text{var}_{a,k}(n) < \text{MIN_VAR})$, then it converges.

For simulations of the cabin noise, MIN_VAR is 0.0003, and $s = e^{(-1/200)}$. For simulations of the engine booming noise, MIN_VAR is 0.003, and $s = e^{(-1/100)}$.