



DYNAMIC CORRECTION OF EXCITATION IN HAND-HELD ELECTRO-PNEUMATIC PERCUSSION MACHINES

E. V. GOLYCHEVA, V. I. BABITSKY AND A. M. VEPRIK

Wolfson School of Mechanical and Manufacturing Engineering, Loughborough University, Loughborough, Leicestershire LE11 3TU, England. E-mail: V.Golycheva@lboro.ac.uk

(Received 3 August 2001, and in final form 28 February 2002)

Vibration levels experienced by operators of hand-held percussion machines are high, causing injuries when operated for the durations common in industry, which is why the design of low-vibration percussion machines is a significant problem. One of the main sources of hazardous vibration of electro-pneumatic percussion machines is an impulsive pressure force developed within an air cushion and applied directly to the machine casing. This paper shows that an additional flexible element added to the exciting piston of the electro-pneumatic hammer improves excitation performance, leading to an extension of acceleration time and a reduction in the intensity of impulses of pneumatic impacts thereby relieving load on the operator. The concept proposed is substantiated by wide simulation of the machine dynamics.

© 2002 Elsevier Science Ltd. All rights reserved.

1. INTRODUCTION

Percussion hand-held machines typically rely on systematic impacts for demolition or treatment of hard materials and are widely used in different areas of industry. Millions of portable chipping machines, riveting and other types of hammers, concrete breakers, impact wrenches, hammer drills, etc., are used in various fields of industry, construction and transport.

A specific feature of this kind of machinery is a permanent direct interaction between operator and machine. Consequently, the percussion machine causes harmful vibration effects to the operator. Long-term use of hand-held percussion machines may result in hand–arm vibration syndrome (HAVS). Various surveys have suggested that over 160 000 workers in Great Britain are exposed to hand–arm vibration, although, the exact number of cases of HAVS is difficult to estimate. It was also found that workers using non-impact machines had a lower prevalence of elbow and shoulder symptoms than those using low-frequency impact machines. Impulses that are produced by the percussion machine and perceived by an operator are an important factor to consider in the design of vibratory machines and in the hazard risk assessment of their use [1, 2]. Normally hand-transmitted vibration has been expressed in units of root-mean-square (r.m.s.) acceleration (m/s^2) which is usually analyzed over a frequency range and neither the calculation of these values nor the measurements emphasize the essential influence of the narrow and high peaks of the vibration signal. Percussion machines, however, produce a vibration primarily due to impulsive interactions between parts of the machine and systematic impacts between the machine and the surface treated [3]. These impulses can produce permanent trauma in human joints and tissues [2].

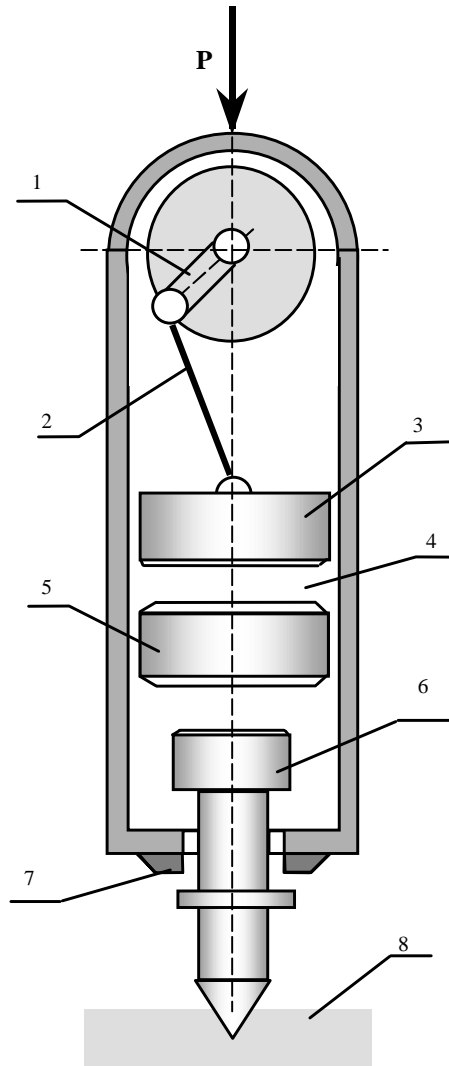

Figure 1. Schematic diagram of an electro-pneumatic hammer.

Design of a low-vibration machine is normally aimed at reducing the vibratory effects on an operator to levels that do not exceed the limits stipulated by health and safety limits and standards. The current investigation deals with an electro-pneumatic hammer, which is of great practical value. Figure 1 shows schematically a typical machine of this category. The electric motor drives the exciting piston (3) via the crank (1) and the connecting rod (2). The piston drives the striker (5) via the air cushion (4). The striker hits the pick (6) which hits the surface (8) being treated and then while rebounding can impact the buffer (7) of the casing. Excitation of the striker is due to the periodic compression of the air in the chamber (4).

The operator has to press the machine to the object with a permanent force (this is called *feed force*), which is the main factor in transferring energy from the excitation source into the medium being treated [3–5]. The feed force, which is considered to be the external force, depends on the interaction of the machine as a whole with the object of

treatment. This includes both the interaction of the striker with a pick or intermediate piston for processing and the positioning of the machine and the pick in an appropriate position against the object being treated. Any additional interactions between the machine and the object of treatment lead to an increase in the feed force applied by an operator and it imposes additional loading upon the operator. Usually, the manufacturer specifies a particular force for particular machine without considering changes in the operator's response over the working process time and possible differences in the operator's physical abilities [6]. In this study, the feed force developed by the operator is considered to be an essential part of the working process for the machine.

The feed force, the force due to rebound and the force that is equal to the sum of the unbalanced inertia forces, is applied to the percussion machine casing and through it to the operator. Since the stiff crank-shaft mechanism does not allow for vibration isolation, the operator also perceives pneumatic impacts. As a result, the main sources of vibration in the electro-pneumatic percussion machine are: (1) pressure force applied periodically to the exciting piston; (2) inertia forces associated with the acceleration of moving parts; and (3) secondary impact between the pick and the buffer after the pick rebound [3, 7–9].

There are a number of different methods for protecting the operator from hand-transmitted vibrations. The first, and probably the most effective method of reducing vibratory effects of the machine on the operator, is to reduce the intensity of sources of harmful vibration through proper design of the machine. Optimal excitation and suitable choice of mechanisms can help to reduce hand-transmitted vibration. The other solution is to add elements for balancing the moving parts of the machine. This method decreases the low-frequency vibration of the machine, but adds complexity to the design and increases the weight and energy consumption of the machine. It usually leads to a cost-inefficient design. Alternatively, a second striker can be added which will act in turn with the first striker and achieve partial balancing. However, in this case, the design of the machine becomes even more complicated [10].

Sophistication of the excitation process can reduce the vibration level and relieve the demands on the isolation system. Babitsky [4] got a theoretical optimal excitation as a result of the solution for the problem equivalent to optimal control, which allows for a reduction in hazardous hand-transmitted vibration and relieves the load on the drive. Currently in the design of electro-pneumatic hammers, excitation is provided by an electrical motor and crank-shaft mechanism. Under these circumstances, the sinusoidal movement of the driving piston is determined by the parameters of crankshaft mechanism and cannot be changed or adjusted. Comparison of the real excitation with the results of optimal analysis showed that an additional passive compliant element attached to the driving piston may allow for excitation to be obtained that is closer to the optimal. The aim of this research is to introduce and investigate this modification and its influence on the dynamic of the percussion machine. The results obtained using numerical simulations confirmed the effectiveness of the proposal.

2. DYNAMIC MODEL OF THE MACHINE

To investigate the dynamic processes in the percussion machine, a lumped parameter model (see Figure 2) is suggested. The model reflects the interaction of all major components of the machine and also the interaction of the system with the surroundings. Hand-transmitted vibration of the machine that is observed in the direction parallel to the stroke direction X is the most significant. The interactions between the machine and the operator in two other directions are not considered. The pressure force in the air cushion

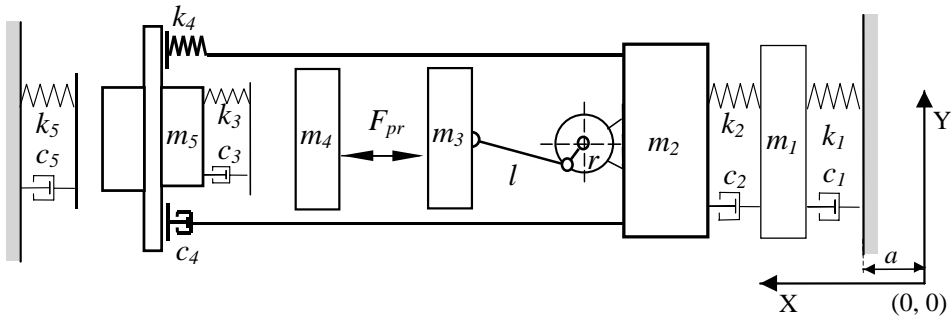

Figure 2. Dynamic model of the pneumatic hammer.

and secondary impact forces between the pick and buffer of the casing have been included to consider major factors that are responsible for vibration.

The operator can control the output of the percussion machine by changing the feed force, and therefore the operator-machine interaction must be considered as part of the system. A simplified model of the human hand has been chosen as a single-degree-of-freedom system which consists of a linear spring-damper combination with the following parameters: $k_1 = 3.55 \times 10^5$ N/m, $c_1 = 300$ Ns/m, $m_1 = 1.8$ kg. These values were obtained from an experiment which relied on the method of mechanical impedance. Masses $m_1 - m_5$ represent masses of the operator's hand, the machine casing, exciting piston, striker and the pick, respectively; k_2, c_2 are the parameters of the vibration isolation system (usually, the rubber cushion on the handle), k_3, c_3 are the mechanical characteristics of contact between the striker and pick, k_4, c_4 are the parameters of the buffer of the casing, k_5, c_5 are the parameters of the linear spring-damper combination reflecting the mechanical characteristics of material being treated; F_{pr} is the parameter representing the pneumatic force between the driving piston and the striker, r is the radius of the crank, l is the length of the connecting rod, S is the length of the compression chamber between the exciting piston and the striker when the pressure in the chamber is atmospheric, and d is the stroke length (when all elastic elements are not deformed, the exciting piston is at the extreme distance from the pick and the position of the striker is determined by the atmospheric pressure in the pneumatic cushion).

The feed force, produced by the operator, is accounted for by changing parameter a with the assumption that the attachment on the left-hand side is fixed (see Figure 2). Here a is the distance between origin of absolute co-ordinates $(0, 0)$ and the attachment of the system on the right-hand side.

It is supposed that the treated material is restored before each new impact, therefore, the process of penetration into the material is not taken into consideration. It is assumed that the character of the demolishing process is unimportant for the investigation of the percussion machine vibration. Consequently, the object being treated is represented as a linear spring-damper combination and does not change its position during the working process.

Equations of motion of each mass take the general form

$$m_i \ddot{x}_i = \sum F_i^{imp} + \sum F_i^{el} + \sum F_i, \quad (1)$$

where $\sum F_i^{imp}$ is the sum of impact forces applied to the mass, $\sum F_i^{el}$ the sum of elasticity forces applied to the mass, and $\sum F_i$ the forces that cannot be described by general formula for force of elasticity or impact (pressure force, driving force).

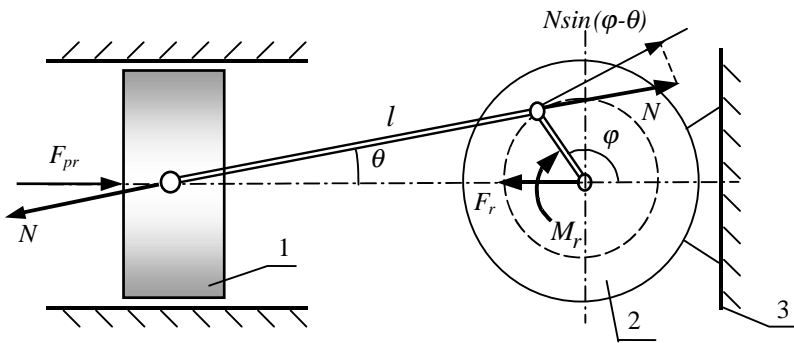

Figure 3. Schematics of forces in “crank slider mechanism-motor”.

The model of visco-elastic impact, which relies on the Kelvin–Voigt model [5], is used as the basis for a description of collisions between parts of the machine. The limiter is modelled as a parallel spring and dashpot and the impact force is calculated using the formula [11]

$$F_i^{imp}(z_i, \dot{z}_i) = \begin{cases} c_i \dot{z}_i + k_i z_i & \text{if } z_i > 0 \text{ and } F_i^{imp}(z_i, \dot{z}_i) > 0 \\ 0 & \text{if } z_i > 0 \text{ and } F_i^{imp}(z_i, \dot{z}_i) \leq 0 \\ 0 & \text{if } z_i < 0, \end{cases} \quad (2)$$

where z_i is the contact deformation. To illustrate, F_3^{imp} is between the striker and the pick, and $z_3 = x_4 - d - x_5$, where x_4 and x_5 are relative displacements of the masses m_4 and m_5 from their equilibrium position.

In a similar manner,

$$F_i^{el} = c_i \dot{z}_i + k_i z_i. \quad (3)$$

Figure 3 shows the forces applied to the ‘crank mechanism – electric driver’ system. The high-speed alternating current commutator motor and high gear ratio of the reducer, which are currently used, allows uniform rotation of the crank to be assumed. Hence, the acceleration of the exciting piston in this case is from the geometry in Figure 3 as follows:

$$\ddot{x}_3 = r\dot{\varphi}^2 \left(\cos \varphi - \frac{r}{l} \cos 2\varphi \right). \quad (4)$$

From Figure 3, the reaction force F_r due to the rigid coupling between the stator and the casing of the machine and torque M_r of the resistance force applied to the mechanism is transferred to the rotor of the motor. In this case, only vibration in the direction parallel to the stroke is considered. As a result

$$F_r = N \cos \theta, \quad M_r = N \sin(\varphi - \theta)r, \quad (5)$$

where $N = m_3 \ddot{x}_3 + F_{pr}$ is the force applied by the driver to the exciting piston, θ is the angle between the connecting rod and horizontal axis and r is the crank radius.

Assuming that the volume of air between the exciting piston and striker remains at all times constant, the conditions in the compression chamber might be considered to be close to isothermal and the pressure in the chamber between the exciting piston and rotor is atmospheric. Hence, the force developed by the air cushion is defined as

$$F_{pr} = pA[S/(S + x_3 - x_4) - 1], \quad (6)$$

where p is the atmospheric pressure, A is the cross-sectional area of a piston, and x_3, x_4 are the relative co-ordinates of the striker and exciting piston. Calculations show that the above simplification of the thermodynamical process does not influence the dynamic behaviour of the model [5].

The above set of equations of motion (1)–(6) for the proposed model enable investigation of the machine–operator interaction and sources of vibration since they include all the major parts of the machine and their mutual interactions.

Non-linearity and complexity of the model make analytical solutions difficult, hence the model has been investigated numerically using Simulink (part of the Matlab 5.3 software suite).

3. NUMERICAL SIMULATIONS

Simulation has been run in the Matlab-Simulink environment. A block diagram is shown in Figure 4 where each block represents a subsystem which is constructed according to equations (1)–(6). Simulation of Simulink models involves the numerical integration of sets of ordinary differential equations (ODEs). Simulink provides a number of solvers for simulation of such equations. The model under consideration has continuous states so variable-step solver *ode45* was chosen. *Ode45* is based on an explicit Runge–Kutta (4, 5) formula, the Dormand–Prince pair. Variable-step solvers can modify their step sizes during simulation. They provide error control and zero crossing detection. The maximum

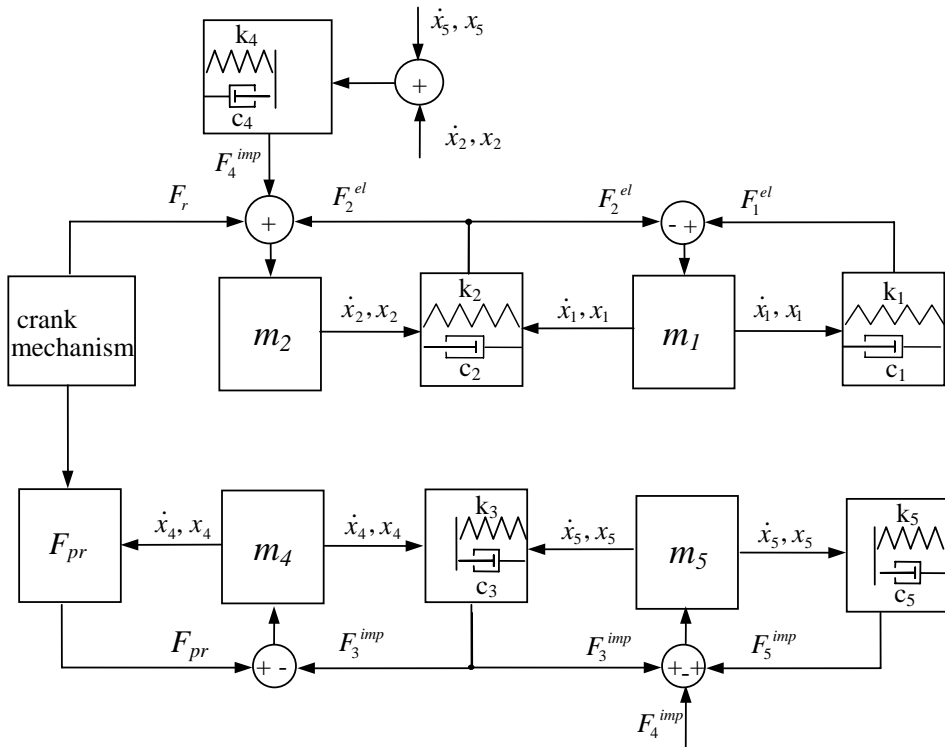

Figure 4. Simulink block diagram of the pneumatic hammer.

step size was set as 1/4 of the period of the process (0.005 s) and the initial step size as 0.0001 s. The solver uses standard local error control techniques to monitor the error at each time step. During each time step, the solvers compute the state values at the end of the step and also determine the local error, and the estimated error of these state values. They then compare the local error to the acceptable error, which is a function of the relative tolerance (set as 10^{-3}) and absolute tolerance (10^{-4}). If the error is greater than the acceptable error for any state, the solver reduces the step size and tries again.

The software allows all dynamic characteristics of the system to be obtained and includes variation of the parameters which are essential for the design of percussion machines, such as the size of compression chamber, crank arm radius, masses of different parts, feed force, etc.

Typical parameters of a heavy hammer drill that have been used in this model are: pre-impact velocity of the pick, $\dot{x}_{5-} = 6$ m/s; mass of the pick, $m_5 = 0.2$ kg; mass of the machine casing, $m_2 = 8$ kg; frequency of impact of the pick against the treated surface, $f = 45$ Hz; approximate stiffness of the treated material, $k_5 = 3 \times 10^7$ N/m and loss factor of the treated material, $\zeta_{5-c_5}/2(k_5 m_5)^{0.5} = 0.7$ obtained using typical characteristics for concrete loading and formula (7) in reference [4].

The size of the compression chamber, stroke length, masses and the rest of the parameters used in the dynamic model of the machine have been found using the Monte-Carlo optimization method so that the root-mean-square value of hand acceleration is minimal for the prescribed velocity of the pick just before impact. By using a random number generator in Matlab 5, N number of simulations were made while values of the parameters were changed randomly and independently within the area of search. Matlab 5 uses a new random number generator that can generate all the floating-point numbers in the closed interval $[2^{-53}, 1-2^{-53}]$. Theoretically, it can generate over 2^{1492} values before repeating itself. After N simulations, an optimal set of values for the parameters used in the dynamic model of the pneumatic hammer was obtained. This optimum set of parameters corresponded to a process frequency value of 45 Hz, velocity of the pick just before impact 6 m/s and minimum r.m.s. value for hand acceleration. The result of the parameter search permitted a narrowing of the search range for each parameter; the range was reduced by one-third using the optimum set as a new centre of the search. The sequence of steps was stopped when the ratio between the current and previous r.m.s. value was greater than 0.95. The number of simulations, N , was equal to 3000 for the first step and reduced by 1/4 for each subsequent step. By this means, the reference model with a rigid exciting piston was obtained for minimum hand acceleration and the predesigned velocity just before impact.

The interaction between the excitation mechanism and the striker as a source of vibration can be analyzed using results of numerical simulations (see Figure 5). The crank slider mechanism has inertia, and therefore, after the piston hits the striker through the air cushion (see point A in Figure 5) it continues moving in the same direction. After the striker rebounds (see point B), the driving piston is still moving forward and resists the backward movement of the striker. Consequently, the striker does not have sufficient acceleration distance and the necessary impact velocity is obtained by increasing the force of the pneumatic impact between piston and striker rather than by using the optimal striker movement. Figure 6 shows the time history of acceleration of the hand of an operator with mass m_1 .

The acceleration curve for the operator's hand results from a combination of compression of the pneumatic spring (peak A) and the secondary impact of the pick against the buffer element of the casing (peak B). There are small peaks, C, on the curve of the force of the secondary impact due to the second rebound of the pick. Peak D is the

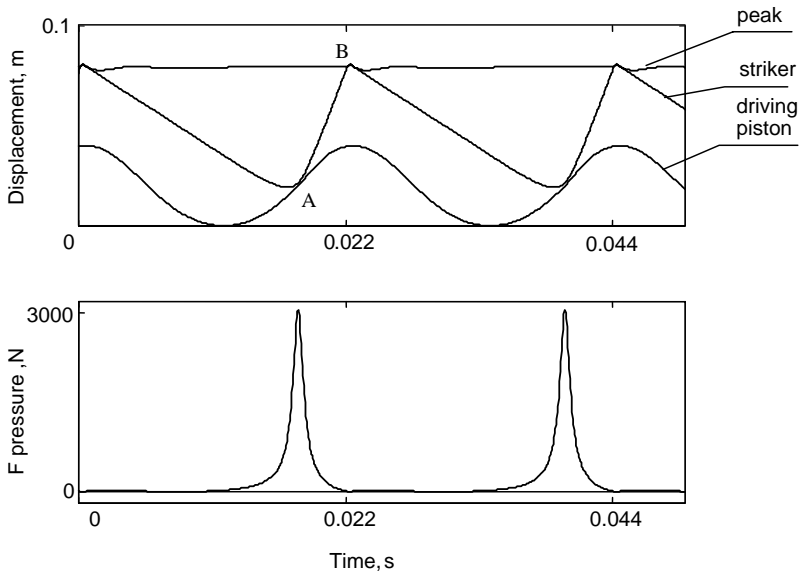

Figure 5. Sample of a time-history of displacements of the moving parts of the excitation mechanism and force of pneumatic impact.

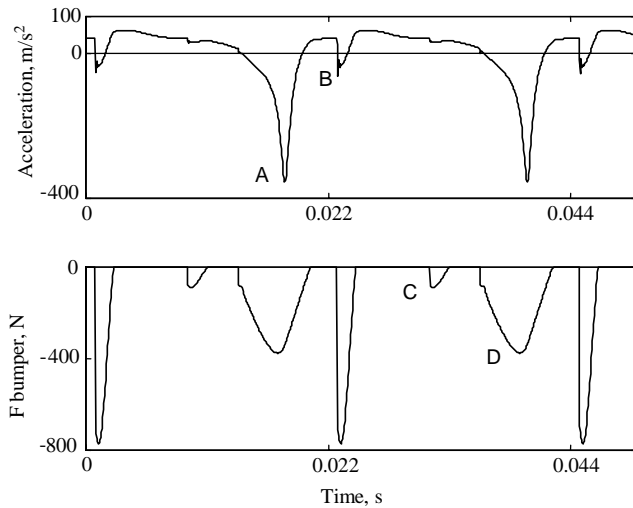

Figure 6. Sample of a time-history of acceleration of the hand of the operator and bumper force.

result of impact of the casing that is pressed against the pick by the spring dashpot combination, k_1 , c_1 , after the pneumatic impact. The value of this peak depends on the chosen dynamic characteristics of the human hand. Considering that these parameters vary from one subject to another, the results obtained were checked with different values of k_1 , c_1 , and m_1 , and the qualitative characteristics of the hand acceleration and bumper force were found to remain unchanged.

Varying the parameters of the buffer, k_4 and c_4 , could decrease peaks due to the secondary impact on the acceleration curve, although in practice, the stiffness of this

element must be high enough to maintain the constant stroke length. The periodicity and capacity of the process is very sensitive to changes in these parameters since they determine the stroke length and, consequently, the velocity just before impact. It is shown below that the excitation performance can be improved by modifying the striker motion.

4. OPTIMAL STRIKER MOTION

The dynamic analysis of the percussion machine shows that the periodic excitation force acting on the striker has a simultaneous opposite action on the casing of the machine and through it on the operator. The results of the numerical simulations (see Figure 6) support this conclusion. The performance of the percussion machine may be improved by optimizing the force of excitation.

The optimal excitation that is necessary to realize a steady state vibro-impact process with a single impact during the period and reduced influence on the operator was obtained by Babitsky [4]. Since, in practice, it is difficult to realize an optimal excitation, the quasi-optimal excitations, $u(t)$, with a condensed acceleration impulse are introduced as follows:

$$u(t) = \begin{cases} -U & \text{if } t \in [0, t_1), \\ +nU & \text{if } t \in [t_1, T), \end{cases} \tag{7}$$

where

$$U = \frac{(1 + R)\dot{x}_s f}{n - (1 + n)/(1 + R)[1 - \sqrt{1 - n(1 - R^2)/(1 + n)}]}, \tag{8}$$

$$\frac{t_1}{T} = \frac{1}{1 + R} \left[1 - \sqrt{1 - \frac{n(1 - R^2)}{1 + n}} \right], \tag{9}$$

where R is the restitution ratio coefficient of striker reflection after the impact, \dot{x}_s is the velocity of striker just before the impact, f is the frequency of impacts, n is the approximating coefficient ($n=1$ corresponds to the optimal excitation), and T is the period of the impacts.

The tendency to reduce the initial negative acceleration and to condense the positive acceleration impulse was observed as a sequence of quasi-optimal approximations. The exciting force acts in the positive direction only when the approximating coefficient value $n = 100$. Further possible estimations of these condensed positive impulses were calculated. The different possible excitations of the striker with the introduction of a permissible duration of the positive impulse, Δ , were obtained. In this case,

$$u(t) = \begin{cases} 0 & \text{if } t \in [0, t_1), \\ U & \text{if } t \in [t_1, t_1 + \Delta), \\ 0 & \text{if } t \in [t_1 + \Delta, T), \end{cases} \tag{10}$$

where U , t_1 are unknown values and $(t_1 + \Delta)/T \leq 1$. The formulas for variables t_1 and U are as follows [4]:

$$\frac{t_1}{T} = 1 - \frac{1}{2} \left(\frac{\Delta}{T} \right) - \frac{R}{1 + R}, \tag{11}$$

$$U = \frac{(1 + R)\dot{x}_s f}{\Delta/T}. \tag{12}$$

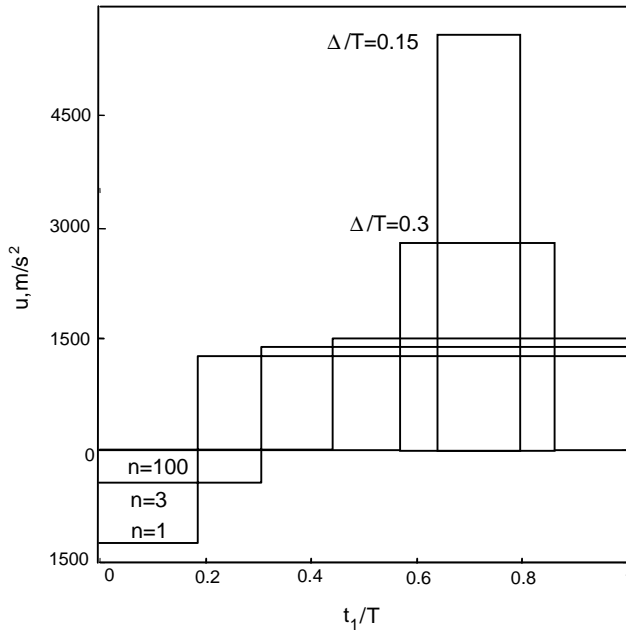

Figure 7. Quasi-optimal excitations with reduced rebound of striker.

Figure 7 shows the possible quasi-optimal excitations drawn in accordance with expressions (7)–(12) for the dynamic system under consideration [4].

The highest values of the excitation force (acceleration impulse) correspond to the shortest values of interval Δ . The worst case, when $\Delta/T = 0.1$, corresponds approximately to the excitation of modern hammers. The force of the pneumatic impact obtained by numerical simulations (see Figure 5) is consistent with Figure 7 since short interactions between the driving piston and the striker cause a high force value.

Analysis of the quasi-optimal excitations obtained suggests that extending the duration of the positive impulses of the excitation force (striker acceleration) may decrease the influence of the process on the operator without affecting the entire performance of the machine. The sluggishness of the crank slider mechanism and electric motor does not allow for permanent control of the striker movements. In this article, the flexible element attached to the piston is proposed, to modify excitation in order to reduce impulses due to pneumatic impact by extending acceleration time.

5. DYNAMIC MODEL WITH MODIFIED EXCITATION MECHANISM

The source of excitation was modified by an additional passive flexible element attached to the driving piston. When the natural frequency of the additional dynamic system is higher than the working frequency, this element works in a spring-control mode and allows extension of the positive impulses of the pneumatic impact.

In order to compare the results, the dynamic model considered here (see Figure 8) is similar to the previous model with the exception that the flexible element is represented as a mass attached to the driving piston by a linear spring and dashpot.

The optimal parameters of the flexible element are as follows: mass $m_e = 0.08$ kg, natural frequency, $\omega_e/2\pi = 170$ Hz and loss factor, $\zeta_e = c_e/2(k_e m_e)^{0.5} = 0.3$ chosen with

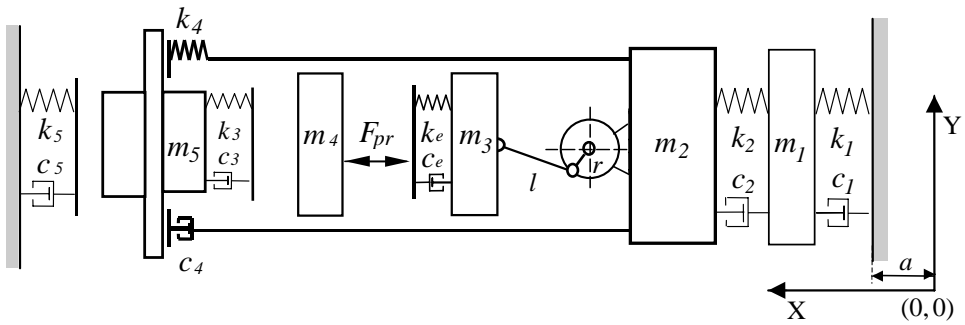

Figure 8. A dynamic model of pneumatic hammer with additional flexible element (membrane).

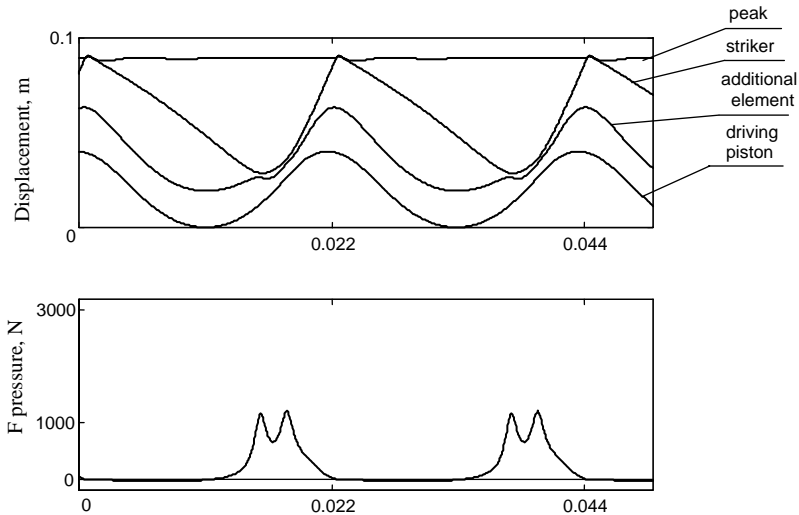

Figure 9. Sample of a time history of displacements of moving parts of the excitation and force of pneumatic impact.

the intention of practical realization of this element. The size of the air chamber and stroke length have been changed in order to obtain the prescribed velocity of the pick just before impact within the single-impact periodic process. The rest of the parameters remain the same as in the previous model.

Figure 9 presents displacements of the driving parts and the force of pneumatic impact. This figure shows that the passive flexible element permits changes of the excitation force so that it is closer to the optimal one. The value of positive impulses corresponding to the force developed by the air cushion are reduced due to an increase in their time duration. In comparison with previous characteristics (see Figure 5), their magnitudes were reduced by a factor of 2-8, whereas the frequency of the process and pre-impact velocity of the pick remained unchanged.

The root mean square of the hand acceleration for the new system with a flexible element was reduced by a factor of 1.4. The most significant effect of introducing the additional flexible element can be seen by comparing the sample of time history of hand acceleration for the original system (see Figure 6) and the modified one (Figure 10). Due to the fact that the parameters of the buffer and the pick remain unchanged, the value of the

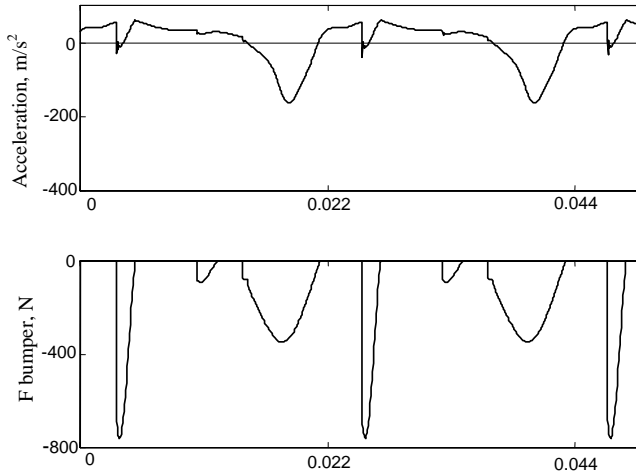

Figure 10. Sample of a time history of acceleration of operator hand and force of secondary impact.

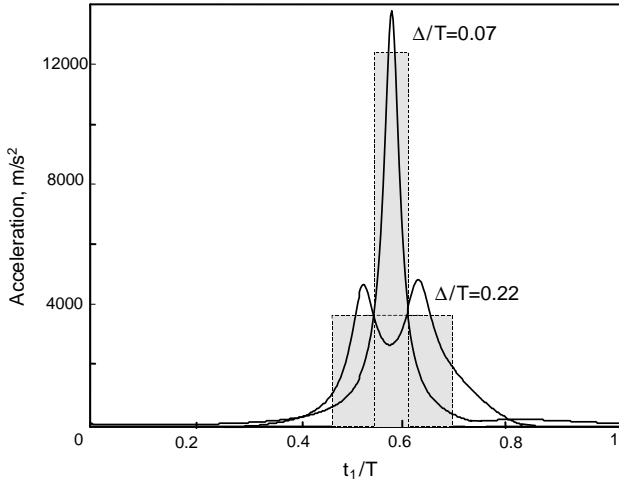

Figure 11. Comparison of different excitations.

buffer force and the corresponding peaks in the acceleration time history do not change whilst the peaks due to the force of the pneumatic impact are reduced by a factor of 2.8.

The impulses in the acceleration of the operator's hand, as mentioned before, are an important factor to consider in the design of vibratory machines and in the hazard risk assessment of machines. Routine measurements do not take peak values of the vibration signals into consideration [12]. However, high-frequency components may be more hazardous in the aetiology of the vibration syndrome than has been previously thought. Decreasing the risk of injury to operators of hand-held machines depends essentially on the degree of impulsiveness of the acceleration perceived by the operator. This is because these impulses can give the most destructive effect in human joints. In some cases, protection from injury can be achieved more effectively by a reduction in the peak values of hand acceleration rather than by a reduction in the value of its r.m.s.

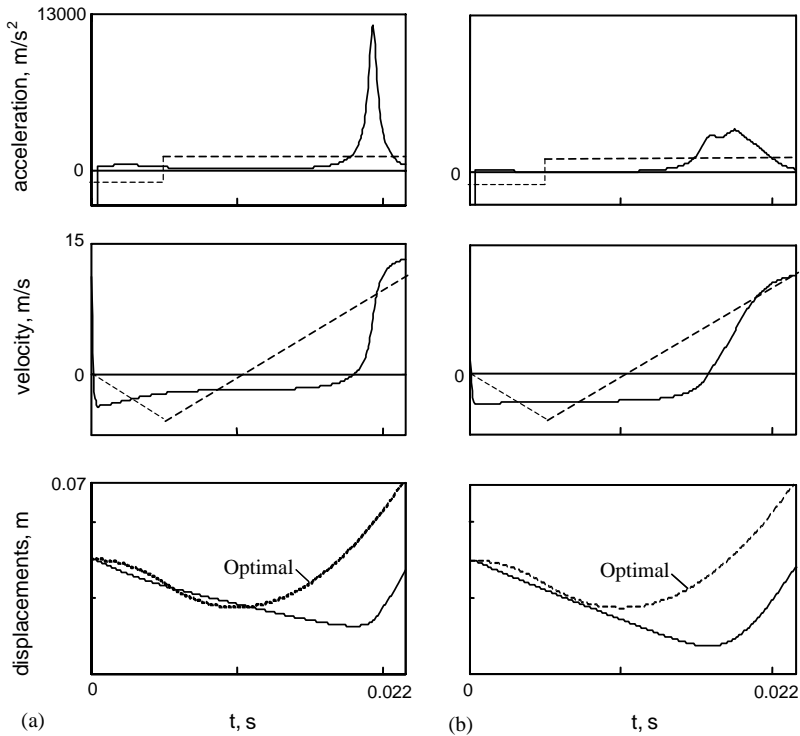

Figure 12. (a) Striker motion for stiff piston, dash line—optimal striker movement [4]; (b) Striker motion for piston with compliant element, dash line—optimal striker movement.

Figure 11 compares the acceleration of the striker for the original model and the model with modified the source of excitation. The shaded area is the closest optimal excitation for each model obtained using equations (10)–(12). A comparison of the quasi-optimal excitation for the original model with excitation for the modified model shows that the duration of the positive acceleration impulse is increased three-fold, while the value of the impulse is decreased by a factor of 3.5. From Figure 7, it can be seen that the effect of extending impulses correlates well with the quasi-optimal excitation for the condensed acceleration impulse. Increasing the impulse time results in a reduction in its magnitude without affecting the pre-impact velocity. Comparison between the striker motion for the system with a rigid piston and for the system with a piston with an additional flexible element shows that modification of the source of excitation generates a striker motion that is closer to the optimal one.

Figure 12 compares the motion of the striker for both systems and the optimal one obtained in reference [4]. Even though changes in the velocity and displacement are not very noticeable, the acceleration curve shows a significant extension of the positive impulse with a reduction in its magnitude. The extension of the accelerating impulses not only reduces the peak force of the pneumatic impact, but also improves the control of the striker movement. The additional flexibility that is added to the driving piston allows for an increase in the time of the actual control of the striker motion by the driving piston. Figure 13 estimates the angle of the crank rotation when the striker accelerates towards the pick by the force developed within the air cushion.

The additional flexible element maintains the fixed distance between the element and the striker that is equal to 3 mm (see Figure 13(b)). In this study, this distance and associated

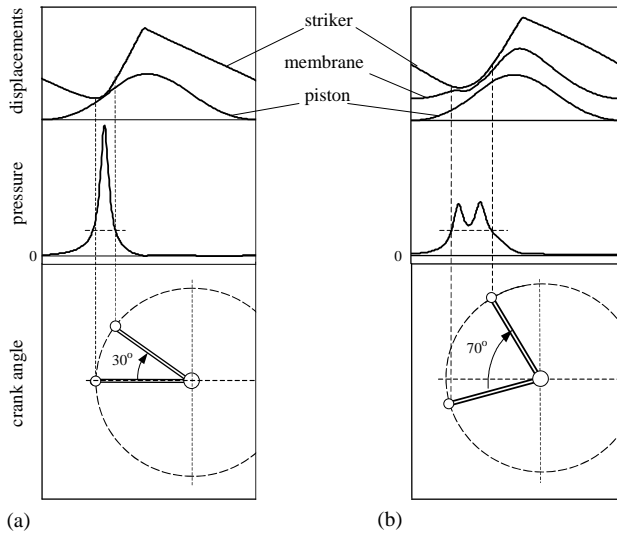

Figure 13. Schematic of crank rotation for the stage of positive acceleration impulse: (a) original model of percussion machine, and (b) model with additional flexible element.

time interval are called the “effective distance” and the “time of effective striker control”. Hence, the time of effective striker control was estimated as 30° crank revolution for the original model (see Figure 13(a)) while introduction of the additional flexible element improves this value to 70° (Figure 13(b)).

Introduction of the additional flexible element attached to the exciting piston does not affect the performance parameters of the percussion machine. The modification does not influence the sensitivity of the characteristics of the process to the feed force applied by the operator, nor does it affect the influence of the buffer parameters.

6. CONCLUSIONS

Modification of the excitation source of an electro-pneumatic hammer by implanting an additional linear spring-mass-damper element to the exciting piston allows for significant improvement in the excitation performance of the hand-held percussion machine. The flexible element extends the impulse duration developed by the air cushion, thereby reducing their values and relieving the load on the operator. The modified source of excitation also realises better control of the striker movements. The possibility of further improvement by introducing nonlinearity into this element may be investigated in future.

Dynamical confirmation of results of the general optimal theory for hand-held percussion machines [4] obtained within the framework of realistic models gives way to the new design concepts of these machines with reduced vibration loading on operators.

REFERENCES

1. J. STARCK 1984 *Scandinavian Journal Work Environment Health* **10**, 171–178. High impulse acceleration levels in hand-held vibratory machines.
2. A. J. BRAMMER and W. TAYLOR 1982 *Vibration Effects on the Hand and Arm in Industry*. New York: John Wiley & Sons, Inc.

3. V. K. ASTASHEV, V. I. BABITSKY and M. Z. KOLOVSKY 2000 *Dynamics and Control of Machines*. Berlin: Springer.
4. V. I. BABITSKY 1998 *Journal Sound and Vibration* **214**, 165–182. Hand-held percussion machine as discrete non-linear converter. Erratum 1999, **222**, 893.
5. V. I. BABITSKY 1998 *Theory of Vibro-impact Systems and Applications*. Berlin: Springer. (Revised translation from Russian 1978, Moscow: Nauka).
6. M. J. GRIFFIN 1990 *Handbook of Human Vibration*. London: Academic Press.
7. R. JAHN and M. HESSE 1986 *Scandinavian Journal Work Environment Health* **12**, 343–346 Applications of hand–arm models in the investigation of the interaction between man and machine.
8. G. BIANCHI, K. V. FROLOV and A. OLEDZKI, editors 1979 *Proceedings of the International CISM-IFTToMM-WHO Symposium, Udine, Italy*, April 3–6. Man under vibration. Suffering and protection.
9. C. E. CREDE 1965 *Shock and Vibration Concepts in Engineering Design*. Englewood cliffs, NJ, New York: Prentice-Hall, Inc.
10. *Vibration Solutions. Practical Ways to reduce the Risk of Hand-arm Vibration Injury*. HSE Books 1997 ISBN 0 7176 09545.
11. V. I. BABITSKY and A. M. VEPRIK 1998 *Journal of Sound and Vibration* **218**, 269–292. Universal bumpered vibration isolator for severe environment.
12. BRITISH STANDARD 1995 BS EN 28662-3. Hand-held portable power tools. Measurements of vibrations at the handle.