



LETTERS TO THE EDITOR



VIBRATION ANALYSIS OF CONSTANT POWER REGULATED SWASH PLATE AXIAL PISTON PUMPS

M. K. BAHR, J. SVOBODA AND R. B. BHAT

*Mechanical Engineering Department, Concordia University, 1455 De Maisonneuve Boulevard West,
Montreal, Quebec H3G 1MG, Canada E-mail: mecheng@vax2.concordia.ca*

(Received 6 June 2001, and in final form 16 April 2002)

1. INTRODUCTION

The static and dynamic characteristics of swash plate axial piston pumps with cylindrical cylinder blocks were extensively investigated during the last three decades. The static and dynamic performance of a pressure compensated swash plate axial piston pump was studied by Zaki and Baz [1]. A linearized model was developed and used to investigate the effect of some operating parameters on the pump performance. This model was adopted by Baz [2] to develop a method for selecting the pump parameters that yield optimum dynamic performance. Akers and Lin [3] applied the optimal control theory to determine the design parameters of the pressure regulator of an axial piston pump, which incorporates a single stage electro-hydraulic servovalve. Modelling and designing a variable geometric volume axial piston pump was also investigated by Manring and Johnson [4], where the effect of factors such as the actuator and discharge hose volumes, controller gain and system leakage on the performance was discussed.

Swash plate pumps with conical cylinder blocks have been recently studied. Kassem and Bahr [5] carried out a comprehensive theoretical study to investigate the effect of the triangular silencing groove dimensions on the piston chamber pressure and pump flow rate. The study led to a recommended valve plate configuration that causes gradual rise and drop in piston chamber pressure, suppresses cavitation and has low pump discharge fluctuations. For this type of pumps, the moment acting on the swash plate was studied theoretically by Kassem and Bahr [6]. It was shown that the component of the moment that must be balanced by the pump control system increases nearly linearly with the increase in the load pressure and/or the decrease in the swash plate inclination angle. Dynamic performance of electrically constant power regulated swash plate pumps was studied theoretically by Kassem and Bahr [7]. In their study, fuzzy logic controller is proposed to replace the PD controller currently in use. It was shown that the fuzzy logic controller shows better pump dynamic performance under both the design and off-design parameters of the control system.

Dynamic performance of the electrically constant power controlled pumps was evaluated earlier from the point of view of the swash plate and the proportional valve spool response to a step change in the load pressure. In the present study, vibration analysis of the proportional valve spool at different operational and design conditions is carried out. The results are presented and discussed.

2. PUMP MATHEMATICAL MODEL

The studied pumping mechanism is shown in Figure 1. The displacement s_k of the k th piston as a function of its angular position θ_k is given by [5]

$$s_k = L - (L_1/\cos \beta) \quad (1)$$

where $L = (0.5D_2 \cos \theta_k \tan \alpha + L_1)/(\cos \beta - \cos \theta_k \sin \beta \tan \alpha)$, $\theta_k = (\omega t + 2\pi(k-1))/N$, $\beta = \tan^{-1} 0.5(D_1 - D_2)/L_2$, and α is the swash plate inclination angle.

Applying the continuity equation to the piston chamber control volume (CV) shown schematically in Figure 2, we get [5]

$$Q_{sk} + A_p \dot{s}_k = Q_{dk} + p_k/R_L + V_{ck} \dot{p}_k/B, \quad (2)$$

where

$$Q_{dk} = C_d A_{dk} (2|p_k - p_d|/\rho)^{1/2} \text{sgn}(p_k - p_d), \quad Q_{sk} = C_d A_{sk} (2|p_s - p_k|/\rho)^{1/2} \text{sgn}(p_s - p_k),$$

and

$$V_{ck} = A_p(0.5L_c - s_k) + V_o.$$

Knowing the pump dimensions, the piston chamber instantaneous pressure p_k can be determined by solving the foregoing equations numerically. The normal force acting on the swash plate due to the k th piston was shown in reference [6] to be

$$F_k^n = (A_p p_k + m_p a_k + m_p \omega^2 r_{ck} \sin \beta + F_s)/(\sin \alpha \cos \theta \sin \beta - \cos \alpha \cos \beta), \quad (3)$$

where $r_{ck} = 0.5D_1 - (x_c + s_k) \sin \beta = 0.5D_1 - (0.5L_p + s_k) \sin \beta$.

With the co-ordinate system shown in Figure 2, the moment acting on the swash plate in its swinging direction due to the k th piston normal force is given by $M_{yk} = F_{zk}^n x_k - F_{xk}^n z_k$, where $x_k = L \cos \theta_k \sin \beta + R_2 \cos \theta_k$ and $z_k = -L \cos \beta + L_1$. The total moment acting on the swash plate due to all pistons is given by

$$M_y = \sum_{k=1}^N M_{yk}. \quad (4)$$

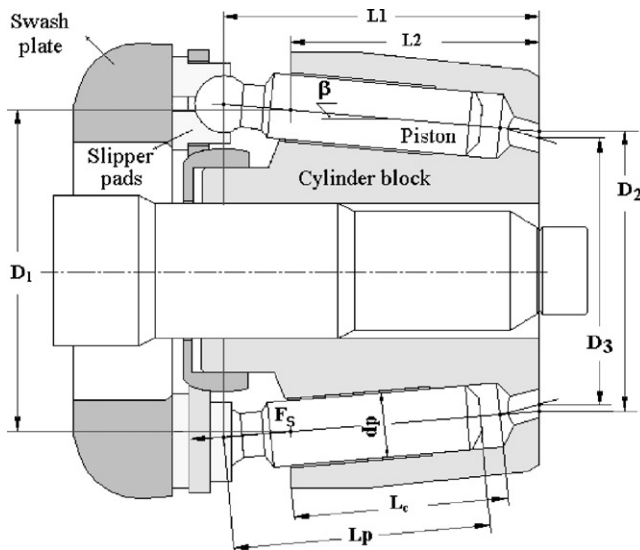

Figure 1. Layout of the pumping mechanism.

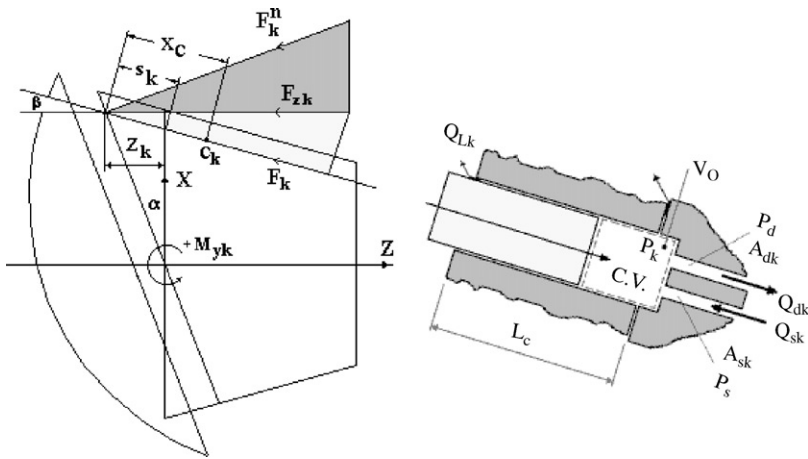

Figure 2. Piston chamber control volume and forces acting on the swash plate.

The moment M_y is the moment that tends to change the swash plate inclination angle, and in variable geometric volume pumps it should be overcome by the pump control system.

The circuit diagram of the control system used for constant power regulation of the pump is shown in Figure 3. The system consists of electronic control card, hydraulic directional proportional valve, a symmetrical hydraulic cylinder and three transducers. In open hydraulic circuits, when the proportional valve is de-energized the control pressure p_v swivels the swash plate to an adjustable minimum value, which should fulfill the pump self-lubrication requirements. It is to be noted that, at constant load pressure, the central position of the proportional valve spool is assumed to be the initial position where the control pressures p_{c1} and p_{c2} are nearly equal. The swash plate is thus held in a certain

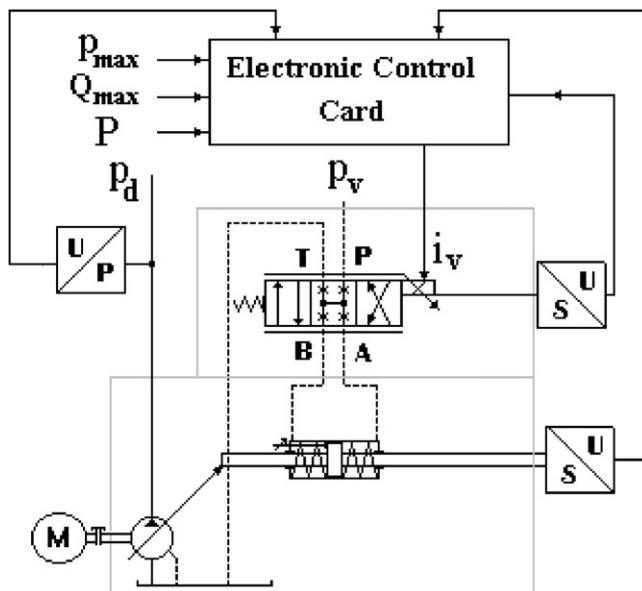

Figure 3. Symbolic representation of the control unit.

position waiting for the next control signal. In this case the proportional solenoid receives a current i_n which nearly equals one half the maximum value. The value of i_n should control the proportional valve spool displacement so as to distribute the control pressure on the control piston sides to overcome the control piston spring force and the mean value of the moment M_y at any swash plate inclination angle. Variation of the load pressure is sensed by the pressure transducer and fed to the arithmetic unit in the electronic control card. The arithmetic unit calculates a new reference value of the swash plate inclination angle corresponding to the load pressure to achieve constant power operation with the static characteristic limits respected. The swash plate inclination angle reference value is compared with the actual value, sensed by the swash plate position transducer, and then the error value is fed to the PD process controller in a negative feedback control loop. The PD process controller consequently generates another reference value of the proportional valve spool displacement. The PD controller has the gains are 8.2 and 0.018 for the proportional and derivative parts respectively. The spool displacement reference value is compared with the actual value that is sensed by the spool displacement transducer. The error value is fed to a PID controller with gains of 13,450 and 0.035 for the proportional, integral and derivative parts respectively. The PID controller generates, in accordance with the input error value, a control current signal i_v , which is fed to the proportional solenoid that causes change in the spool displacement. Proportional valve spool displacement causes oil to flow through the four control gaps of the valve so as to control the position of the control piston. When the proportional valve receives an actuating electrical signal from its electronic control card higher than i_n , the control piston moves in such a direction that increases the swash plate inclination angle and hence the pump geometric volume. When the new steady state is reached, the current passing through the proportional valve solenoid becomes again a new i_n . The equations governing the dynamics of the hydro-mechanical part of the control system, shown schematically in Figure 4, were first presented in reference [7]. The model was validated in reference [7] with good agreement between the simulated pump performance and that provided by the pump manufacturer.

In this paper, a new approach was presented through which the equation of motion of the swash plate was derived considering the forces acting on the control piston. When the proportional valve solenoid receives a control current i_v , a force proportional to this current; namely $k_i i_v$, acts on the valve spool and causes it to move. The equation of motion of the valve spool is

$$m_v \ddot{s}_v + f_v \dot{s}_v + k_v s_v = k_i i_v. \quad (5)$$

Assuming a constant discharge coefficient and negligible valve leakage, for the open center type valve we get

$$Q_a = C_d w (s_{v \max} - s_v) (2|p_{c1} - p_T|/\rho)^{1/2} \text{sgn}(p_{c1} - p_T), \quad (6)$$

$$Q_b = C_d w s_v (2|p_v - p_{c1}|/\rho)^{1/2} \text{sgn}(p_v - p_{c1}), \quad (7)$$

$$Q_c = C_d w (s_{v \max} - s_v) (2|p_v - p_{c2}|/\rho)^{1/2} \text{sgn}(p_v - p_{c2}), \quad (8)$$

$$Q_b = C_d w s_v (2|p_{c1} - p_T|/\rho)^{1/2} \text{sgn}(p_{c2} - p_T) \quad (9)$$

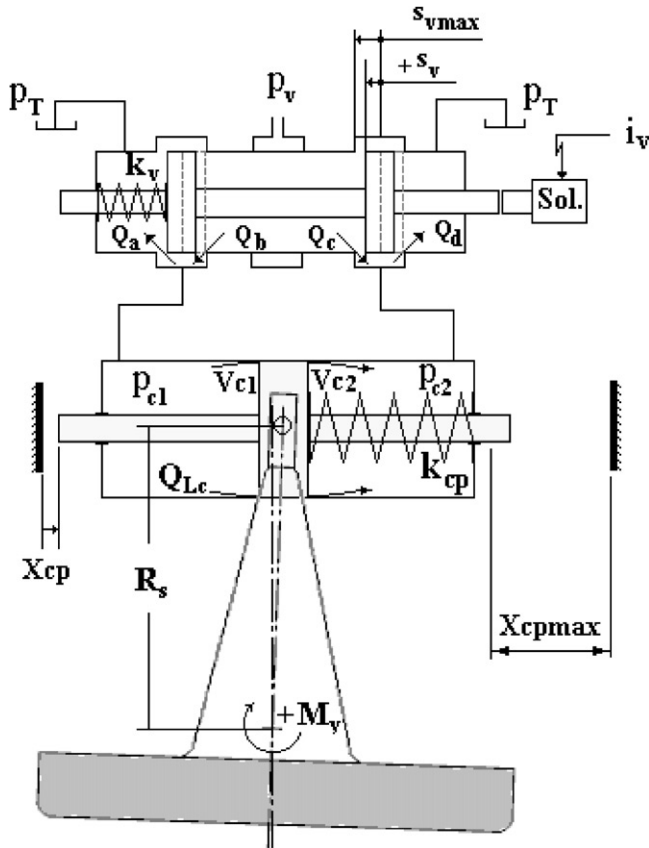

Figure 4. Schematic representation of the hydro-mechanical part of the control unit.

Applying the continuity equation, it can be shown that the pressures p_{c1} and p_{c2} are given by

$$p_{c1} = \frac{B}{V_{c1}} \int (Q_b - Q_a - A_{cp} \dot{x}_{cp} - p_c / R_L) dt, \quad p_{c2} = \frac{B}{V_{c2}} \int (Q_c - Q_d + A_{cp} \dot{x}_{cp} + p_c / R_L) dt \quad (10)$$

where $V_{c1} = V_{ci} + A_{cp} x_{cp}$ and $V_{c2} = V_{ci} - A_{cp} x_{cp}$.

The pressure difference on the two sides of the control piston drives it to a new equilibrium position. The instantaneous angular speed and swash plate inclination angle are then given by

$$\dot{\alpha} = \frac{1}{I_e} \int [(p_{c1} - p_{c2}) A_{cp} R_s + M_y - f_{\alpha} \dot{\alpha} - k_{\alpha} (\alpha + 0.09)] dt, \quad \alpha = \int \dot{\alpha} dt, \quad (11, 12)$$

where the value of f_{α} considers the damping at the control piston as well as the swash plate supporting bearings, while the value of k_{α} considers the spring action at the control piston. Value of I_e consider the moment of inertia of the swash plate and the parts attached to it as well as the moving mass of the control piston.

3. PUMP SIMULATION AND PERFORMANCE EVALUATION

A Matlab–Simulink simulation program was first introduced in reference [7], in order to simulate the pump dynamic performance. This program has been further developed in the present study based on the new approach in calculation of the swash plate instantaneous inclination angle. Simulation for different constructional and operational parameters for a 9-piston pump, of size 40 cc/rev running at 1450 r.p.m., were carried out. At first, the swash plate is assumed to be held fixed by an external means at 7.5° inclination angle, which is equal to 50% of its maximum inclination angle. In this position, computer runs were carried out without considering the control action to calculate the moment M_y at different load pressures; namely 10, 20 and 30 MPa by solving the equations (1) – (4) simultaneously.

As shown in Figure 5, the moment fluctuates between low positive and high negative peak values. A Fourier analysis of the periodic lateral moment at each load pressure shows nine harmonics and a negative mean value. The frequency of the fundamental is approximately 24 Hz, which is the pump rotational speed. The negative mean value of the lateral moment tends to drive the swash plate towards the minimum position, and its absolute value increases with the increase of the load pressure.

The control pressure difference across the control piston, P_c , was then assumed to have constant value such that the swash plate is left free to move. The value of P_c at each load pressure was chosen to overcome the control piston spring force and the mean value of the moment M_y when the swash plate was positioned at 50% of its maximum inclination angle. Computer runs were carried out, taking into consideration the absence of the control action, to simulate the motion of the swash plate under the effect of the lateral

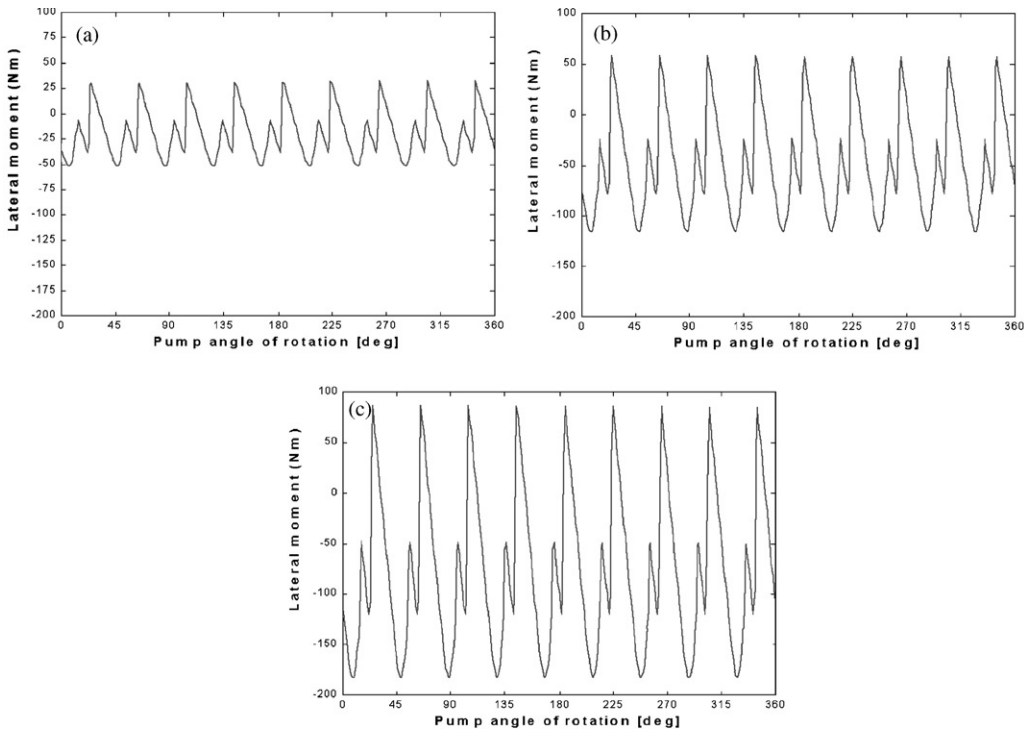

Figure 5. Lateral moment acting on the swash plate at different load pressures: (a) $p_d = 10$ MPa, mean value = -10 Nm; (b) $p_d = 20$ MPa, mean value = -35 Nm; (c) $p_d = 30$ MPa, mean value = -67 Nm.

moment. Simulation results, for the swash plate inclination angle response under the exciting moment M_y , are shown in Figure 6. Evidently, the swash plate inclination angle fluctuates periodically around 50% of its maximum value with amplitude increases with the increasing load pressure. Fourier analysis for the swash plate forced vibration shows that it contains the same frequencies as in the lateral moment.

Figure 7 shows the simulation with the controller included to eliminate the swash plate vibration and keep it positioned at the desired value so as to achieve constant power operation with the variable load pressure. It shows the periodic vibration of the proportional valve spool under steady state conditions. Fourier analysis for the valve spool vibration, at different load pressures, reveals that the mean values increase with the increase in load pressure, and shows that the frequency content in the spool vibration is the pump rotational speed and its integer multiples. This can be explained as follows. To keep the swash plate position at the desired value, the valve spool fluctuates in an opposite manner to the swash plate fluctuation in order to compensate the effect of the lateral moment acting on the swash plate. It is to be noted that, regardless the steady state value of the swash plate inclination angle and affecting by the lateral moment, the steady state mean value of the spool displacement increases with the increase in the load pressure.

Using different types of hydraulic oil as well as oil aging and/or change of the amount of the entrained air to the oil may cause a change in the oil bulk modulus. Simulation runs were carried out to investigate the effect of the oil bulk modulus on the pump performance. The oil bulk modulus was assumed to be at 50% and 150% of the design value while keeping the load pressure constant at 30 MPa. Simulation results shown in Figure 8 are compared with those when the design value of the bulk modulus is used. A

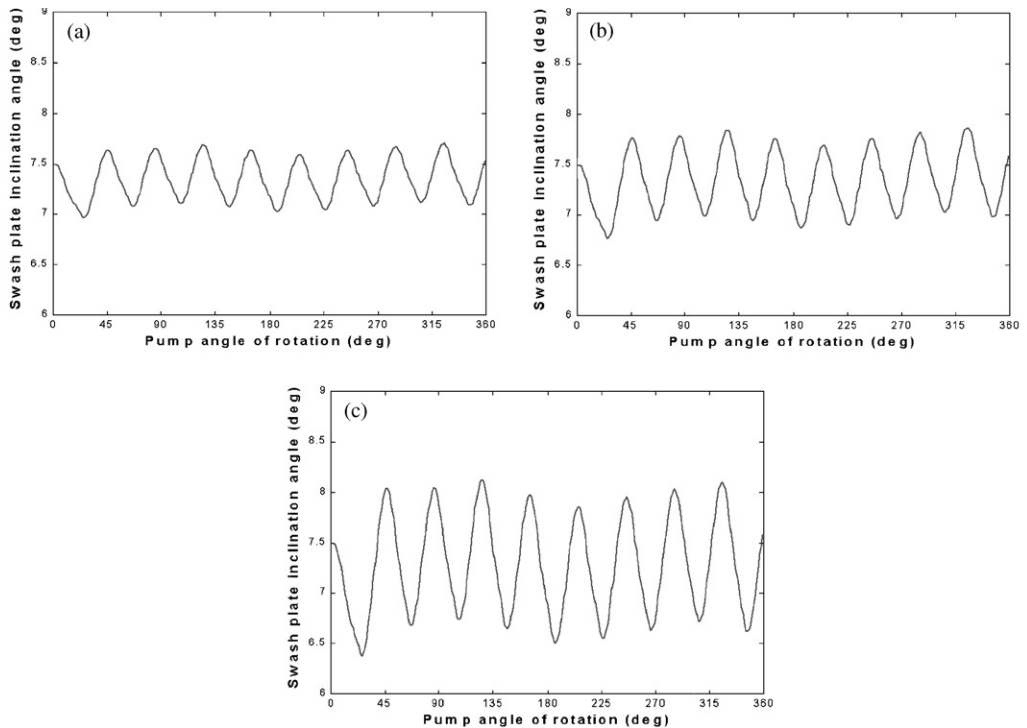

Figure 6. Swash plat forced vibration under the effect of the lateral moment: (a) $p_d = 10$ Mpa, mean value = 7.5°; (b) $p_d = 20$ Mpa, mean value = 7.5°; (c) $p_d = 30$ Mpa, mean value = 7.5°.

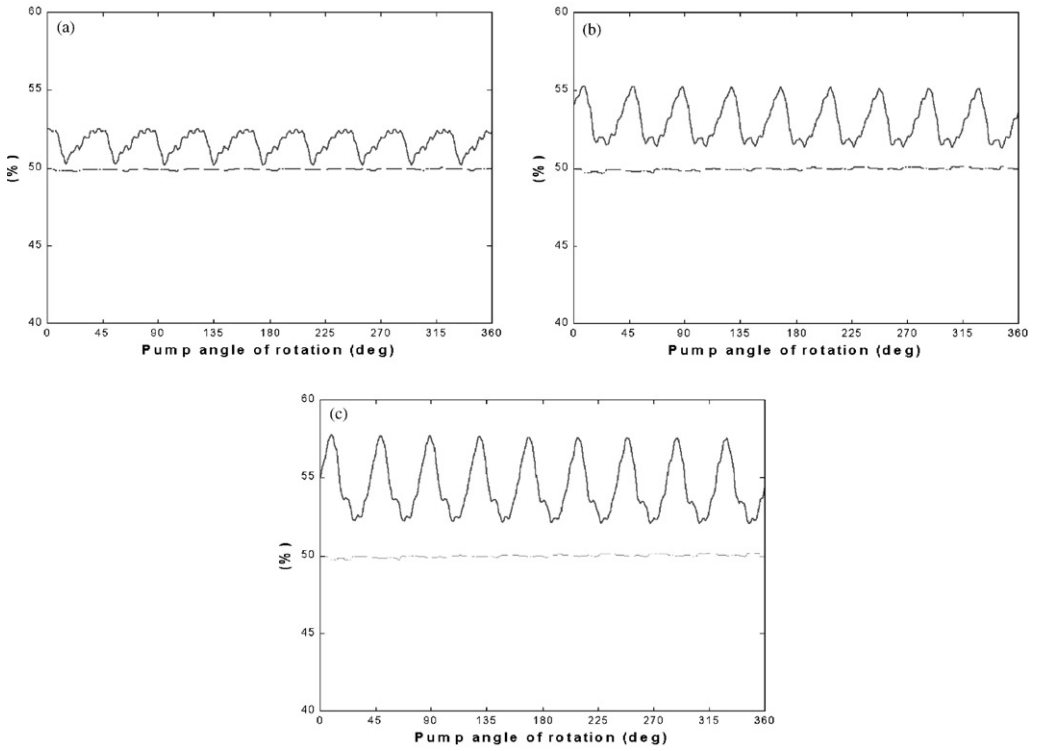

Figure 7. Effect of the load pressure on the pump performance: (a) $p_d = 10$ Mpa; (b) $p_d = 20$ Mpa; (c) $p_d = 30$ Mpa; —, spool displacement; · - · - ·, swash plate inclination angle.

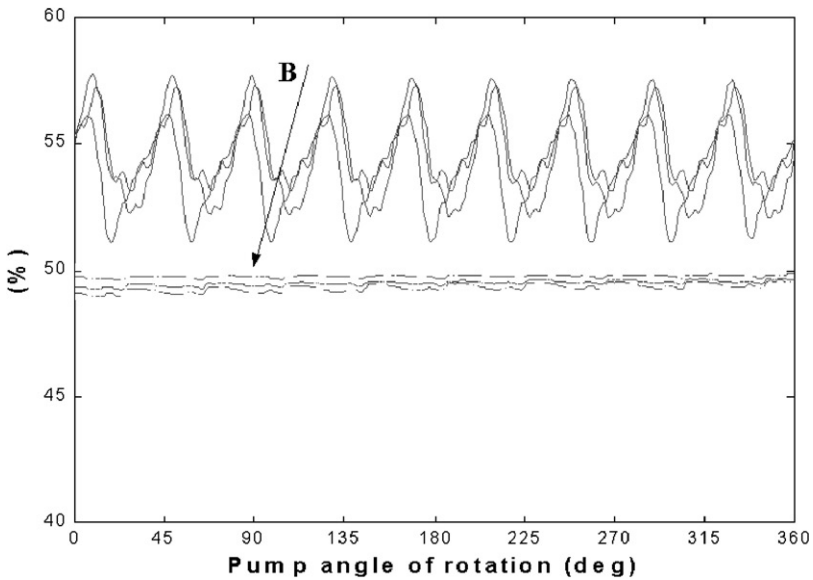

Figure 8. Effect of the hydraulic oil bulk modulus on the pump performance: (a) $p_d = 10$ Mpa; (b) $p_d = 20$ Mpa; (c) $p_d = 30$ Mpa; —, spool displacement; · - · - ·, swash plate inclination angle.

similar comprehensive study was conducted to investigate the effect of the damping coefficient at the proportional valve spool and its spring stiffness as well as those of the control piston on the spool vibration and the swash plate steady state inclination angle. Results are shown in Figures 9–12 respectively. Results show that changing both the damping coefficients and the spring stiffness, within the proposed limits, affect the amplitude of the spool vibration differently, which led to a drift in the swash plate steady state inclination angle evaluated approximately to be from 0.5% to 1.5% of the maximum angle. It is to be noted that, in all cases, the damping coefficient has relatively less effect as compared with the effect of the spring stiffness.

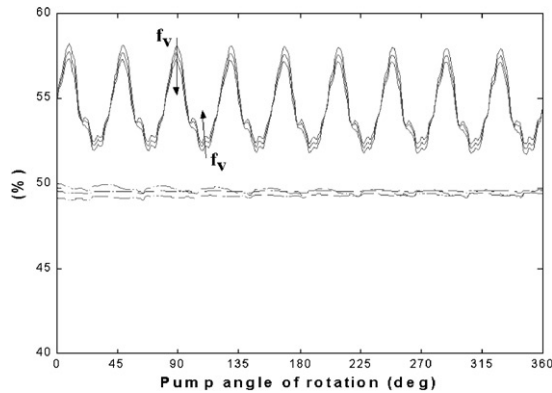

Figure 9. Effect of the valve spool damping coefficient on the pump performance: (a) $p_d=10$ Mpa; (b) $p_d=20$ Mpa; (c) $p_d=30$ Mpa; —, spool displacement; · — · — · —, swash plate inclination angle.

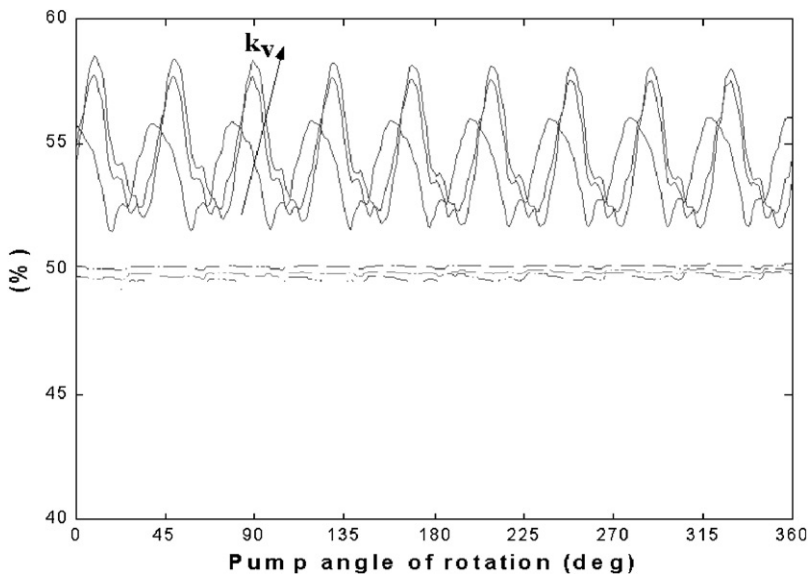

Figure 10. Effect of the valve spool spring stiffness on the pump performance: (a) $p_d=10$ Mpa; (b) $p_d=20$ Mpa; (c) $p_d=30$ Mpa; —, spool displacement; · — · — · —, swash plate inclination angle.

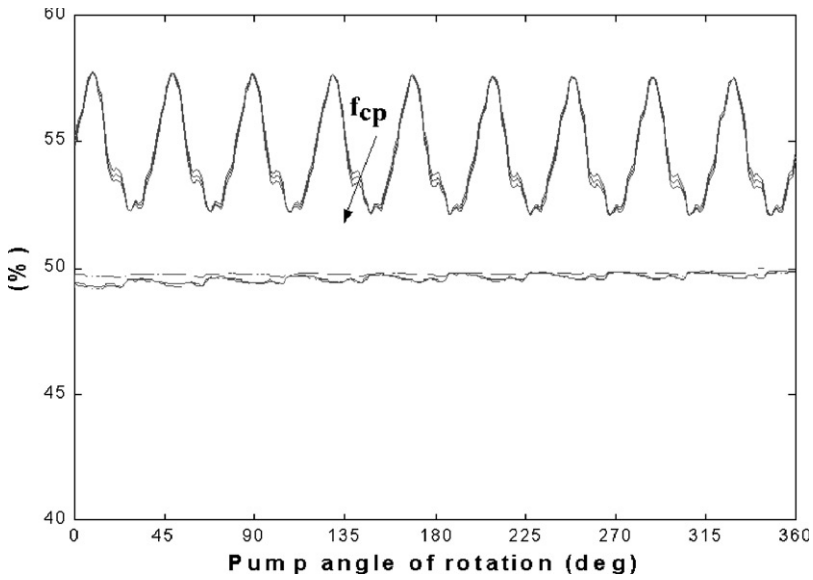

Figure 11. Effect of the control piston damping coefficient on the pump performance: (a) $p_d=10$ Mpa; (b) $p_d=20$ Mpa; (c) $p_d=30$ Mpa; —, spool displacement; $\cdot - \cdot - \cdot -$, swash plate inclination angle.

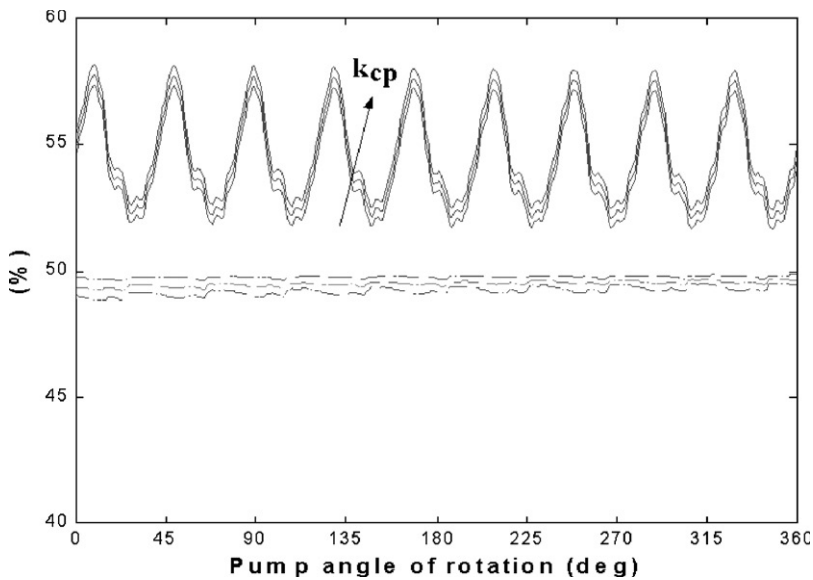

Figure 12. Effect of the control piston spring stiffness on the pump performance: (a) $p_d=10$ Mpa; (b) $p_d=20$ Mpa; (c) $p_d=30$ Mpa; —, spool displacement; $\cdot - \cdot - \cdot -$, swash plate inclination angle.

4. CONCLUSION

A mathematical model was developed to investigate the vibration characteristics of the pumping mechanism of constant power regulated swash plate axial piston pumps with conical cylinder blocks. The obtained simulation results show that the lateral moment

acting on the swash plate fluctuates in a periodic fashion and contains nine harmonics and a negative mean value. The frequency of the first harmonic is at the pump rotational speed, and the frequencies of the higher harmonics are integer multiples of the first one. The negative mean value of the lateral moment tends to drive the swash plate towards the minimum position, and its absolute value increases with the increase of the load pressure. In order to control the swash plate inclination angle to be nearly constant and equal to the desired value, under the effect of the excitation of the lateral moment, the proportional valve spool vibrates in a periodic fashion with the same frequencies as those in the lateral moment. A comprehensive theoretical study was carried out to investigate the influence of damping coefficients and the spring stiffness of the control valve and the control piston, as well as the oil bulk modulus, on the valve spool vibration. Simulation results with variation of these parameters within 50–150% of the design values show that they do not affect the steady state swash plate inclination angle considerably.

REFERENCES

1. H. ZAKI and A. BAZ 1979 *Journal of Fluidic Quarterly* **11**, 73–87. On the dynamics of axial piston pumps.
2. A. BAZ 1980 *Journal Fluid Control* **20**, 64–81. Optimization of the dynamics of pressure-compensated axial piston pumps.
3. A. AKERS and S. J. LIN 1987 *Proceedings of the American Control Conference* **3**, 1865–187. The control of an axial piston pump using single-stage electrohydraulic servovalve.
4. N. D. MANRING and R. E. JOHNSON 1996 *Journal Dynamic Systems, Measurement, and Control* **118**, 267–272. Modeling and designing a variable-displacement open-loop pump.
5. S. A. KASSEM and M. K. BAHR 2000 *Proceedings of the Seventh Mechanical Design and Production Congress MDP7*, 139–148. Pergamon Press. Oxford: Effect of port plate silencing grooves on performance of swash plate axial piston pumps.
6. S. A. KASSEM and M. K. BAHR 2000 *Proceedings of the Sixth Triennial International Symposium on Fluid Control Measurement and Visualization Flucom 2000 Conference, Sherbrooke, Canada*. On the dynamics of swash plate axial piston pumps with conical cylinder blocks.
7. S. A. KASSEM and M. K. BAHR 2001 *Proceedings of the International Mechanical Engineering Congress and Exposition ASME-ME2001, New York*. Fuzzy logic control of constant power regulated swash plate axial piston pumps.

APPENDIX A: NOMENCLATURE

$A_d(A_s)$	delivery (Suction) port area m^2
A_{cp}	area of the control piston ($= 8.1 \times 10^{-4} \text{m}^2$)
A_p	piston cross-section area ($= 2.27 \times 10^{-4} \text{m}^2$)
a_k	kth piston acceleration m/s^2
B	effective bulk modulus ($= 1 \times 10^9 \text{Pa}$)
C_d	coefficient of discharge ($= 0.611$, dimension)
D_1	diameter of cylinders' pitch circle at cylinder block base ($= 0.07175 \text{m}$)
D_2	diameter pitch circle diameter at cylinder block top. ($= 0.0602 \text{m}$)
D_3	diameter of pitch circle of valve plate ($= 0.0547 \text{m}$)
d_p	piston diameter ($= 0.017 \text{m}$)
f_{cp}	control piston viscous friction coefficient ($= 500 \text{N.s/m}$)
F^n	piston force acting normally on the swash plate (N)
F_s	spring force per piston (15 N)
f_v	proportional valve viscous friction coefficient ($= 90 \text{N.s/m}$)
$F_{x,y,z}$	normal force components acting on the swash plate (N)
I_e	equivalent moment of inertia of the swash plate (kg m^2)
i_v	proportional valve solenoid current (A)
k	piston number in the piston group arrangement (dimensionless)

k_{cp}	control piston spring stiffness (24×10^3 N/m)
k_i	proportional solenoid force-current constant (2.5 N/A)
k_v	proportional valve spring stiffness (= 20000 N/m)
L	variable length (m)
L_1, L_2	lengths, referred in Figure 1 (= 0.0766, 0.0661 m)
L_c	cylinder length (= 0.0573 m)
L_p	piston length (= 0.591 m)
m_p	piston mass (= 0.118 kg)
m_v	proportional valve spool mass (= 0.1 kg)
M_y	lateral moment acting on the swash plate (Nm)
N	number of pistons (= 9 dimensionless)
n	prime-mover speed (= 1450 r.p.m.)
P	value of the controlled constant power (kW)
p_c	pressure difference across the control piston (Pa)
$p_{c1,2}$	pressure at the two sides of the control piston (Pa)
p_d	pump delivery pressure (Pa)
p_k	piston chamber pressure (Pa)
p_{max}	static characteristic maximum pressure (Pa)
p_s	pump suction pressure (= 0.05×10^5 Pa)
p_T	tank line pressure (= 1×10^5 Pa)
p_v	control pressure (Pa)
$Q_{a,b,c,d}$	flow rates through proportional valve ports (m^3/s)
Q_d	delivery flow of one cylinder (m^3/s)
Q_{max}	static characteristic maximum flow (m^3/s)
Q_s	suction flow rate into one cylinder (m^3/s)
R_L	leakage resistance (= 1×10^{13} Pa/(m^3/s))
r_{ck}	radius of piston center of gravity trace (m)
s_k	piston displacement (m)
$s_{v(max)}$	proportional valve spool displacement (maximum) (= 0.001 m)
t	time (s)
$V_{c1,2}$	control volume on the two sides of the control piston (m^3)
V_{ci}	initial control volume (= 13×10^{-6} m^3)
V_{ck}	instantaneous cylinder volume of the k th piston (m^3)
V_o	additional piston chamber volume (= 1×10^{-6} m^3)
w	proportional valve area factor (= 4.8×10^{-3} m)
x_c	distance between piston spherical head center and piston center of gravity (m)
$x_{cp} (min, max)$	control piston displacement (minimum, maximum) (= 0, 0.015)m)
x_k, y_k, z_k	cartesian co-ordinates of piston spherical head center (m)
$\dot{s}_k, \dot{x}_{cp}, \dot{s}_v$	velocity of k th piston, control piston, valve spool (m/s)
$\dot{\alpha}$	swash plate angular velocity (s^{-1})
α	swash plate angle of inclination
β	cylinder block cone angle (= 5°)
θ_k	angular position of the k th piston
ρ	oil density (= 850 kg/m^3)
ω	pump angular velocity (s^{-1})