

# Resonance phenomena of an elastic ring under a moving load

G.L. Forbes\*, R.B. Randall

*School of Mechanical and Manufacturing Engineering, University of New South Wales, Sydney 2052, Australia*

Received 5 September 2007; received in revised form 2 May 2008; accepted 10 May 2008

Handling Editor: L.G. Tham

Available online 20 June 2008

---

## Abstract

This study investigates the response of a circular ring under a moving load. Past work on shells under the influence of moving loads is consolidated, with explanation of the formation of the unique quasi-stationary mode shapes, which are seen under these conditions. This work presents an alternate method of solution for problems for which moving loads are present and encourages distinguishing between normal mode shape methods and the solution methods for the proposed quasi-stationary resonance problems. This alternate method is then followed through to a general solution for quasi-stationary mode shapes, with specific solutions presented for the following three cases: magnitude-varying moving point load, phase varying moving point load and a non-uniform continuous moving load, all applied to a stationary ring.

© 2008 Elsevier Ltd. All rights reserved.

---

## 1. Introduction

The motivation for the work described in this paper is an investigation into whether information about turbine blade natural frequency can be extracted from the dynamic motion of the turbine casing under operating conditions. This would provide advantages over the currently prominent method of blade tip timing, which requires perforation of the casing. Operating conditions within a gas turbine present unique, spatially varying, loading conditions, which are described within subsequent sections of this paper. Specifically the moving pressure fields around the inside of the casing due to the pressure profiles around the rotor blades, cause harmonically varying moving pressure forces on the inside of the casing, which is the basis for the solution derived in Section 5.3. Furthermore, the vibration of individual rotor blades will cause the rotating pressure profiles around the rotor blades to be modulated by the blades' dynamic motion; and thus the response to a phase modulated moving force is required, giving rise to the solution presented in Section 5.2.

Historically the vibration of rings, and the extension to the case of cylindrical shells, have been of research interest for quite some time with many authors adding to the body of knowledge, starting with Love [1] presenting the first full representation of the coupling of the transverse bending and in-plane compression waves within a shell in his definitive work. Many hundreds of research papers have been, and continue to be produced using Love's deep curve shell model and the work contributing to this area of knowledge on forced shell vibrations due to a spatially stationary load needs no introduction and is indeed vast. Further improved

---

\*Corresponding author. Tel.: +61 2 9385 6864.

E-mail addresses: [gareth.forbes@student.unsw.edu.au](mailto:gareth.forbes@student.unsw.edu.au) (G.L. Forbes), [b.randall@unsw.edu.au](mailto:b.randall@unsw.edu.au) (R.B. Randall).

modelling assumptions on top of Love's work accounting for rotatory inertia, nonlinearities and shear deformation have also found quite a large amount of attention in research. Driven by the number of physical applications, predominantly in the automotive and locomotive industries, can, under modelling assumptions, be represented as a rotating ring under forced conditions. The additional problem of a rotating ring subjected to a spatially stationary load has also received quite a large amount of research interest, with the solution first presented in a complete form by Carrier [2] as reported in Refs. [3,4].

In addition to the abovementioned two types of loading viz. (i) stationary ring under spatially stationary load, (ii) rotating ring under a spatially stationary load, there exists a third unique problem set of steady-state loading a shell might undergo, this being; (iii) a stationary ring under a spatially varying load. It is to be noted that this third steady-state condition may be analysed as an extension of the first (i) however the unique response form, different mode shapes, and problem solution is believed to warrant distinguishing between the two, and is recommended by these authors for future study of this type of loading and response conditions.

Due to the large amount of work that has been developed in the former two categories, the small amount of work previously carried out on the response of a ring under a moving load is surprising. It is the aim of this paper to bring together the current work on such a case, to provide a single point of reference for solution methodology, and additionally to add some more specific solutions, explanations, amendments and physical interpretation of this response phenomenon.

The first work found on moving loads applied to a stationary shell was by Liao and Kessel [5], in which the case of a constant speed moving point load on a cylindrical shell was treated, and for the first time the resonance conditions for a moving point load were shown to be present when  $\Omega = \omega_{nk}/n$ . The physical reasoning behind the division by the mode number for a resonance condition is explained in Ref. [6]. Response of a rotating ring under a stationary load and the inverse case of a stationary ring under the influence of a constant speed moving point load were compared in Ref. [3], with the formulation of the equations for the response derived using the same two modal parameter method that is used for the inextensional rotating ring case. In Ref. [4] the problem of a stationary ring, and additionally in Ref. [7] for a cylinder, under a moving point load and comparison to the inverse problem was taken further, with the introduction of a (harmonically) magnitude-varying moving point load case. The general periodic magnitude-varying point load case was also then investigated, as was a moving distributed load within a specified arc range. The percentage error if the distributed load was assumed as a point load was also given. The "method of images" was used in Ref. [8] to find the response of a ring supported by a visco-elastic spring base, subject to a moving point load. It was found by Metrikine and Tochilin [8] that resonance occurred when the ring length is divisible by a wavelength of a wave radiated by the load or the load speed was close to the minimum phase velocity of waves in the ring.

Various engineering problems involve axisymmetric structures under the influence of moving loads, including but not limited to: the casing of Gas Turbines, under the rotating pressure fields from rotor blades; planetary gear systems, with the sun and ring gears under the influence of the force of the moving planet gears; the outer race of rolling element bearings, from forces transmitted through the moving rolling elements; and submarine vessels, from rotating pressure fields from the propeller. The first application of a moving load case to a real physical problem, of a rotating harmonic internal pressure loading on the internal surface of a fan casing, due to the pressure difference between rotating blades, was initially investigated in Ref. [9]. The results obtained were however unclear as to the response form, and in addition the poor experimental verification found by the author added to inconclusive outcomes being drawn from this work. A nonlinear harmonic balance method was developed in Ref. [10] for the same form of forcing conditions as examined in Ref. [9]. However, the only resonant condition examined was the system's exhibition of a dynamic response typical of a hardening spring nonlinear system.

Recently, Canchi and Parker [11] introduced the problem case of a circular ring subjected to forces applied by moving springs to model the interaction within a planetary gearbox with the gear mesh between the planet gears and ring gear represented as a set of moving springs which rotate with the planet carrier speed, and further expanded to include variations in the spring stiffness with respect to time in Ref. [12]. The work in Ref. [11] investigated the parametric instabilities of in-plane bending vibrations, with two numerical methods used to validate the parametric analytical approach used for solution. The principal resonance conditions found by Canchi and Parker [11] for moving spring sets on a stationary ring were of the same type as found by Huang

and Soedel [3], however extra parametric resonances were found due to the force being transmitted to the ring through spring sets and not a directly applied force as in Ref. [3].

Most recently the authors, giving the motivation for this article, have developed the response of a gas turbine casing under the influence of a phase varying moving harmonic pressure force, to simulate the rotating pressure fields inside a gas turbine. The dominant, purely deterministic, pressure loadings were investigated in Ref. [13], with further extension to the response of an elastic ring under the influence of a moving stochastic pressure force in Ref. [14]. This is believed to be the first investigation of an elastic ring under a stochastic moving load.

Experimental verification of any moving load solutions is scarce, with the work in Refs. [9] and [15] the only known results available. As stated earlier, the experiments conducted in Ref. [9] were inconclusive, however more success was found by Penneton et al. [15], where the response and sound radiation of a cylindrical shell under a constant speed moving point load was undertaken. Good correlation between experimental results and an analytical model were shown with a frequency-domain approach to represent the load used to aid the analytical solution process.

The aforementioned papers represent the entire body of research, known to us, conducted on the response of shells under a moving load. In general, they have been limited to the inextensional assumption, with the notable exception of Ref. [3]. Because these studies are not completely exhaustive, this has given the opportunity for the collation and interpretation of all present work, the presentation of a new method for solution, new specific solution cases without the relaxation of the inextensional assumption, to be followed in the subsequent sections.

## 2. Problem and equation formulation

The governing equations of motion for a stationary ring have been presented, and solved, by many previous authors, and were presented in Ref. [6] in the following form:

$$\begin{aligned} \frac{EI}{R^4} \left( \frac{\partial^3 u_0}{\partial \theta^3} - \frac{\partial^4 u_3}{\partial \theta^4} \right) - \frac{EA}{R^2} \left( \frac{\partial u_0}{\partial \theta} + u_3 \right) + q'_3 &= \rho A \frac{\partial^2 u_3}{\partial t^2} \\ \frac{EI}{R^4} \left( \frac{\partial^2 u_0}{\partial \theta^2} - \frac{\partial^3 u_3}{\partial \theta^3} \right) + \frac{EA}{R^2} \left( \frac{\partial^2 u_0}{\partial \theta^2} + \frac{\partial u_3}{\partial \theta} \right) + q'_\theta &= \rho A \frac{\partial^2 u_0}{\partial t^2} \end{aligned} \quad (2.1)$$

Note that the forcing terms are per unit length, if Eq. (2.1) is divided by the ring width, then the force is given as a pressure. Also  $I$  is the second moment of area about the neutral axis and  $A$  is the cross sectional area. The effects of Poisson's ratio are neglected in a circular ring assumption (as opposed to a circular cylinder, see Ref. [6] for a more thorough discussion of this).

If the usual assumption is made that the steady-state response is harmonic in time and the time and spatial variables are separable, then it can be shown that

$$\begin{aligned} u_3(\theta, t) &= A_{nk} e^{jn\theta} e^{j\omega_{nk}t} \\ u_\theta(\theta, t) &= B_{nk} j e^{-jn\theta} e^{j\omega_{nk}t} \end{aligned} \quad (2.2)$$

is a fundamental solution of the equations of motion. Solution of the equations of motion must provide the response form for any kind of loading which the system is under. It is known that for a spatially stationary load or under free vibration the response form will be made up of forward and a backward travelling wave which combine to create a response of a harmonically varying standing wave form. It is then the convention to make a judicious choice of the solution form of the equations of motion such that the mode shapes are usually expressed as [6,16,17]

$$\begin{aligned} u_3(\theta, t) &= A_{nk} \cos(n\theta) e^{j\omega_{nk}t} \\ u_\theta(\theta, t) &= B_{nk} \sin(n\theta) e^{j\omega_{nk}t} \end{aligned} \quad (2.3)$$

Solution for the frequency at which these modes vibrate, natural frequencies, can be found with substitution of Eq. (2.3) into Eq. (2.1). Dividing by width ' $b$ ' and setting the forcing terms to zero gives the homogenous

equation (2.4):

$$\begin{bmatrix} C_{11} & C_{12} \\ C_{21} & C_{22} \end{bmatrix} \begin{bmatrix} u_3 \\ u_\theta \end{bmatrix} = \begin{bmatrix} 0 \\ 0 \end{bmatrix} \tag{2.4}$$

where

$$\begin{aligned} C_{11} &= -\frac{D}{R^4} \left( \frac{\partial^4}{\partial \theta^4} \right) - \frac{K}{R^2} - \rho h \left( \frac{\partial^2}{\partial t^2} \right) \\ C_{12} &= \frac{D}{R^4} \left( \frac{\partial^3}{\partial \theta^3} \right) - \frac{K}{R^2} \left( \frac{\partial}{\partial \theta} \right) = -C_{21} \\ C_{22} &= \frac{D}{R^4} \left( \frac{\partial^2}{\partial \theta^2} \right) + \frac{K}{R^2} \left( \frac{\partial^2}{\partial \theta^2} \right) - \rho h \left( \frac{\partial^2}{\partial t^2} \right) \end{aligned}$$

Solution of Eq. (2.4) will produce the natural frequencies by resolving when the determinant is set to zero and for the amplitude ratios by back substitution of the eigenvalues into Eq. (2.4) resulting in

$$\omega_{nk}^2 = \frac{K_1}{2} \left( 1 \pm \sqrt{1 - 4 \frac{K_2}{K_1^2}} \right) \tag{2.5}$$

where

$$\begin{aligned} D &= \frac{Eh^3}{12} \\ K &= Eh \\ K_1 &= \frac{(n^2 + 1)}{R^2 \rho h} \left( \frac{n^2 D}{R^2} + K \right) \\ K_2 &= \frac{n^2(n^2 - 1)^2}{R^2(\rho h)^2} DK \\ \frac{B_{nk}}{A_{nk}} &= \frac{(n/R^2)[(n^2 D/R^2) + K]}{\rho h \omega_{nk}^2 - (n^2/R^2)(D/R^2 + K)} \end{aligned} \tag{2.6}$$

Note that the *k*-subscript is introduced to represent the two unique solution types that come from the fourth-order characteristic equation, the higher order frequency is associated with the compression dominated mode shapes and the lower order frequency is in turn associated with the bending mode shapes. Although these mode shapes are coupled such that both compression and bending are always present, from now on reference to the compression or bending mode shapes refers to the respective dominated mode shape.

A problem however arises when what was a convenient judicious choice of the solution form is then used when the sought forced vibration solution is no longer spatially stationary. It is fundamental to all steady-state forced vibration solutions that the response form must also follow the same form as the force itself. With this it is easily recognised that a harmonically varying standing wave form cannot be the solution form when a spatially non-stationary load is applied. It therefore requires the use of different mode shape functions from those in Eq. (2.3), for the solution under a moving load.

The solution of the problem of a circular ring under a moving force was handled by Huang and Soedel [3] using a modified method of normal mode expansion for a stationary load. The solution was solved for the modal participation factors in the form of

$$\begin{aligned} u_3(\theta, t) &= \sum_{n=1}^{\infty} \alpha_n(t) \cos(n\theta) + \beta_n(t) \sin(n\theta) \\ u_\theta(\theta, t) &= \sum_{n=1}^{\infty} C_n \alpha_n(t) \sin(n\theta) - C_n \beta_n(t) \cos(n\theta) \end{aligned} \tag{2.7}$$

The assumed mode shapes were given as

$$\begin{aligned} u_3(\theta) &= \cos n(\theta - \phi) \\ u_\theta(\theta) &= C_{nk} \sin n(\theta - \phi) \end{aligned} \tag{2.8}$$

with  $\phi$  being an arbitrary angle set by the spatial position of the load at the initial conditions [6].

The creation of Eq. (2.7) from the given standing wave mode shapes in Eq. (2.8) was not developed in Ref. [3]. The initial position of the load which causes the mode shapes in Eq. (2.8) to orientate themselves such that the maximum deflection is at the load point is given by the angle  $\phi$ , however in the cause of a moving load this angle is no longer a constant but a function of the load’s motion and therefore a variable in time,  $\Omega t$ . Substitution of this variable for the mode shape orientation into Eq. (2.8) will result in Eq. (2.9), which then can be separated in time and space to the form which was used in Ref. [3] in Eq. (2.7):

$$\begin{aligned} u_3(\theta, t) &= \cos n(\theta - \theta^* - \Omega t) \\ u_\theta(\theta, t) &= C_{nk} \sin n(\theta - \theta^* - \Omega t) \end{aligned} \tag{2.9}$$

or in complex form:

$$\begin{aligned} u_3(\theta, t) &= \text{Re}(e^{jn(\theta - \theta^*)} e^{-jn\Omega t}) \\ u_\theta(\theta, t) &= \text{Re}(j e^{-jn(\theta - \theta^*)} e^{-jn\Omega t}) \end{aligned} \tag{2.10}$$

where  $\theta^*$  is the initial location of the load.

Eq. (2.10) can now be seen to be in the general canonical form of solution for the equations of motion, which was stated in Eq. (2.2). It is now proposed that the solution of forced vibrations of shells under moving loads use mode shapes in the form of Eq. (2.10), and only considering positive frequencies the reason for which will be further explained later.

Solution of the equations of motion Eq. (2.1) with Eq. (2.10) can be shown to have the same form as the solutions in Eqs. (2.4) and (2.5). However, with  $\Omega = \omega_{nk}/n$ , it is clear that at this load rotational frequency resonance will occur [3,4,6]. If we follow the nomenclature that was first used by Timoshenko [18], as reported in Ref. [19], in his initial work with infinite beams subject to a moving load, this resonance phenomenon will be further referred to as a quasi-stationary resonance condition and denoted by  $\tilde{\omega}_{nk}$ . The use of this description arises from the deformation being stationary to a Newtonian observer but harmonic in space and time with respect to a Euclidian reference. It is also noted that this response phenomenon is referred to as a resonance and not a natural frequency as it is dependent on the loading type, and does not follow the conventional meaning of a natural frequency.

### 3. General solution for quasi-stationary modes

The generalised solution for quasi-stationary modes is formed in the same way as any modal expansion solution, but with the assumption of the mode shapes in their complex exponential form, which reduces the need for solving for two modal participation factors, of Eq. (2.10), as stated earlier.

Formation of the frequency equation is achieved by substitution of the assumed mode shapes into the equations of motion; therefore, the quasi-stationary resonance condition can now be defined as (remembering again that only the positive frequencies are to be considered):

$$\tilde{\omega}_{nk}^2 = \frac{K_1}{2n^2} \left( 1 \pm \sqrt{1 - 4 \frac{K_2}{K_1^2}} \right) \tag{3.1}$$

$$C_{nk} = \frac{B_{nk}}{A_{nk}} = \frac{(n/R^2)[(n^2 D/R^2) + K]}{\rho h \tilde{\omega}_{nk}^2 n^2 - (n^2/R^2)(D/R^2 + K)} \tag{3.2}$$

The above solutions for the quasi-stationary resonance frequencies and amplitude ratios can be seen to be the same as for normal modes in Eqs. (2.5) and (2.6), respectively, though with substitution of  $\omega_{nk}/n = \tilde{\omega}_{nk}$ .

The method for construction of the equations for the displacement of a forced solution using modal expansion is readily available in texts such as Ref. [6]. They will however be stated below for the first time in their entirety for quasi-stationary resonance conditions.

The forced response by the use of modal expansion assumes the following form:

$$\begin{aligned}
 u_3(\theta, t) &= \sum_{n=1}^{\infty} \sum_{k=1}^2 P_{nk}(t) e^{jn(\theta-\theta^*)} \\
 u_\theta(\theta, t) &= \sum_{n=1}^{\infty} \sum_{k=1}^2 C_{nk} P_{nk}(t) j e^{-jn(\theta-\theta^*)}
 \end{aligned}
 \tag{3.3}$$

To solve for the modal participation factor the above Eqs. (3.3) are substituted into the equations of motion, and making use of the orthogonality of the equations, the following ordinary differential equation is formed:

$$\ddot{P}_n + \frac{\lambda_n}{\rho h} \dot{P}_n + n^2 \tilde{\omega}_n^2 P_n = F_n
 \tag{3.4}$$

where  $F_n$  is the Fourier series expansion of the forcing function  $q_i$ . The subscript  $i$  is introduced as a place holder for the two axis directions, such that

$$\begin{aligned}
 F_n &= \frac{1}{\rho h N_n} \int_{\theta} (q_i \text{conj}(U_{in})) R d\theta \\
 N_n &= \int_{\theta} (U_{in} \text{conj}(U_{in})) R d\theta
 \end{aligned}
 \tag{3.5}$$

It is noted from the above equation (3.5), that only positive frequency values will produce a non-trivial solution, which as stated above will be an assumption for quasi-stationary mode shapes.

For a steady-state solution, Eq. (3.4) can be written as

$$\ddot{P}_n + 2\zeta_n n \tilde{\omega}_n \dot{P}_n + n^2 \tilde{\omega}_n^2 P_n = F_n^* e^{jn\Omega t}
 \tag{3.6}$$

where

$$\zeta_n = \frac{\lambda_n}{2\rho h n \omega_{nq}}$$

and  $F_n^*$  is the spatially separated part of  $F_n$ . Therefore, if we let

$$P_n = A_n e^{j(n\Omega t - \phi_n)}$$

then the response is a harmonic series of the driving force with the magnitude and phase lag contribution from each mode given by

$$A_n = \frac{F_n^*}{n^2 \tilde{\omega}_{nk}^2 \sqrt{(1 - (\Omega/\tilde{\omega}_{nk})^2)^2 + 4\zeta_n^2 (\Omega/\tilde{\omega}_{nk})^2}}
 \tag{3.7}$$

$$\phi_n = \tan^{-1} \left( \frac{2\zeta_n (\Omega/\tilde{\omega}_{nk})}{1 - (\Omega/\tilde{\omega}_{nk})^2} \right)
 \tag{3.8}$$

$$u_3(\theta, t) = \sum_{n=1}^{\infty} \sum_{k=1}^2 A_{nk} e^{j(n\Omega t - \phi_n)} e^{jn\theta}
 \tag{3.9}$$

$$u_3(\theta, t) = \sum_{n=1}^{\infty} \sum_{k=1}^2 C_{nk} A_{nk} j e^{j(n\Omega t - \phi_n)} e^{-jn\theta}
 \tag{3.10}$$

The above general solutions can be applied to any moving load case. The important points to be taken from this general solution method is that different mode shapes, modal participation factors and principal resonance frequencies need to be used in moving load cases in comparison to a spatially stationary load case.

#### 4. Discussion on the generalised resonance phenomenon

Now that the general solution of the equations of motion of an elastic shell subjected to a moving load have been found, an investigation into the quasi-stationary resonance conditions can be undertaken.

The geometric and material properties used in this example case are shown in Table 1 (see Fig. 1). Plots of mode number vs. resonance frequency for both normal modes and quasi-stationary modes are shown in Fig. 2. At each natural frequency of the system, a backward and forward travelling wave is set up in the material, at a velocity related to the natural frequency and given by  $v = f\lambda$ , with either a bending or compression dominated mode shape. As the ratio of mode number to radius becomes larger, the influence of the shell’s curvature, and indeed the coupling between these mode shapes, lessens such that the bending mode shapes act like bending modes of a beam and the compression modes act like longitudinal modes in a beam. This is seen in Fig. 2 for the normal modes, where the compression modes begin to show a non-dispersive frequency relationship whereas the bending waves continue to have a dispersive frequency relationship. Under the influence of a moving load, resonance obviously occurs when the load’s velocity matches that of any mode of vibration, therefore if the modes begin to exhibit a non-dispersive frequency relationship, then all modes of vibration will have the same wave velocity and as such under a moving load at this frequency all modes will be excited. This resonance behaviour is seen in Fig. 2, for the quasi-stationary modes, where the graph of mode number vs. resonance frequency asymptotically converges to a single frequency being the material’s wave speed,  $c = \sqrt{E/\rho}$ . A load travelling at this velocity will cause a shock wave, with waveforms being set up in front of the load. Further insight into this particular phenomenon for straight beams can be found in Ref. [19].

Table 1  
Geometric and material properties for examples

Density	$\rho = 7.85 \times 10^{-9} \text{ N s}^2/\text{mm}^4$
Young’s modulus	$E = 20.6 \times 10^4 \text{ N/mm}^2$
Mean radius	$R = 100 \text{ mm}$
Radial thickness	$h = 2 \text{ mm}$

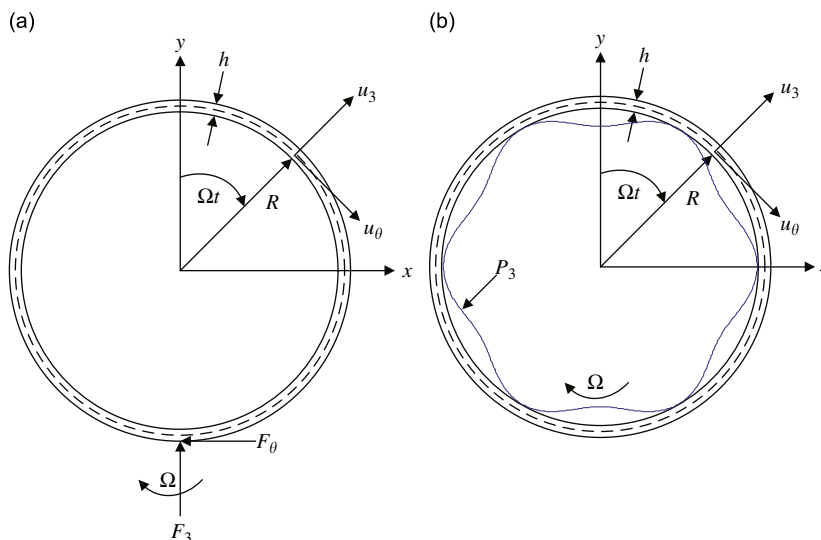

Fig. 1. Travelling point load (a) and rotating pressure loading (b) on a circular ring.



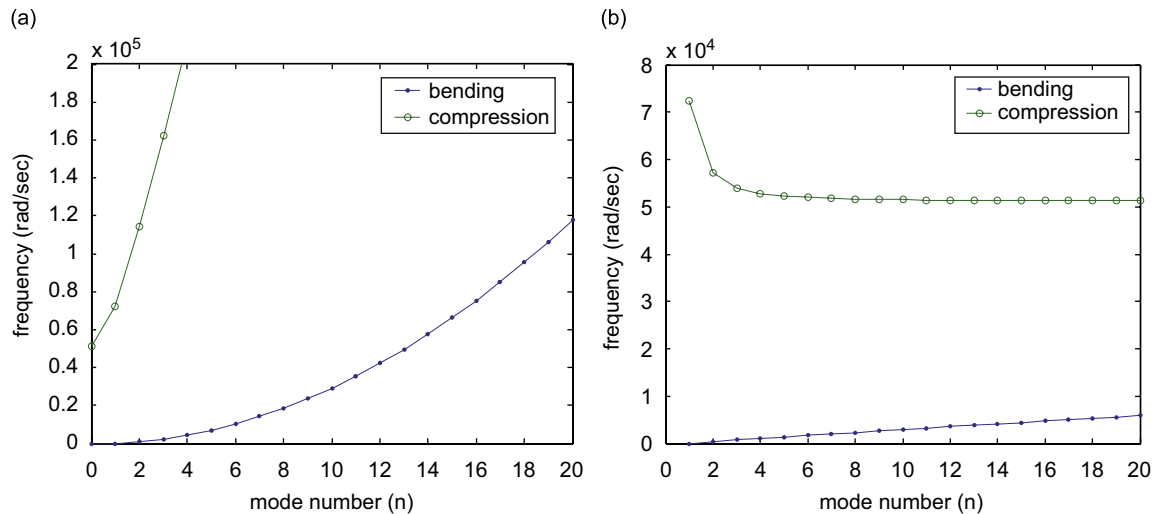

Fig. 2. Natural frequencies vs. mode number for (a) stationary normal mode shapes and (b) quasi-stationary mode shapes.

Interestingly, a rotating ring under a stationary load, which is the inverted load case of a moving load on a stationary ring, exhibits no resonance conditions under a stationary load as found by Huang and Soedel [3], Canchi and Parker [12], and others. As was stated above, for a moving load on a stationary ring, resonance occurs when the load velocity matches the wave speed velocity for any mode of vibration, which means for resonance in a rotating ring under the influence of a stationary load, the ring's rotational speed must be equal to any mode's wave speed. It is shown in Ref. [3] that for a rotating ring, the natural frequency, and hence the material wave speed, bifurcates around the rotational speed of the rotating ring, due to the coriolis and centrifugal tension components. Thus, the rotational velocity of the ring will never equal the wave speed within the material, such that no resonance conditions for the inverted case of a rotating ring under a stationary load will exist.

Lastly, the physical explanation of how quasi-stationary mode shapes which travel around the circumference of a ring can exist will be entered into. It is known that a single impulse load on a structure will create sets of forward and backward travelling waves which combine to create standing normal mode shapes. It can also be assumed that a travelling point load could be, in the limit, made from a sum of infinite impulse loads spaced at an infinitesimally small distance from each other around the circumference of a ring, which are applied with a time delay proportional to the load's circumferential velocity. This means as the first impulse load is applied forward and backward waves are set up, which happens again with another impulse load at an infinitesimally small distance away, and so on as the load travels around the ring. If the fourth-order quasi-stationary mode was excited, i.e. the load is travelling at the fourth-order mode's wave velocity in the material, with the aid of Fig. 3 it can be explained how quasi-stationary modes can develop. It is seen that when the first of the impulse loads at a specific starting position (a) is applied, travelling waves are set up, with the forward travelling wave moving at the speed of the load. When the load has travelled one third of a wavelength (b) it is seen that the forward and backward waves at the starting position and at the load's position are cancelled out, leaving one forward travelling wave. This continues for the next set of waves set up at the next infinitesimal distance up until two-thirds of one wavelength (c). Then all backward waves are cancelled out and the resonance condition of a single wave travelling with the impulse load then exists (d). Additionally, this explanation provides an interesting result, qualitatively showing that a transient component will exist up until two-thirds of a wavelength of the lowest mode of interest, however after this time a complete steady-state solution exists.

## 5. Specific solutions

The solution to the following specific loading cases all involve the same process of determining the radial and tangential displacement of the shell using the procedure outlined in the general solution method. The only



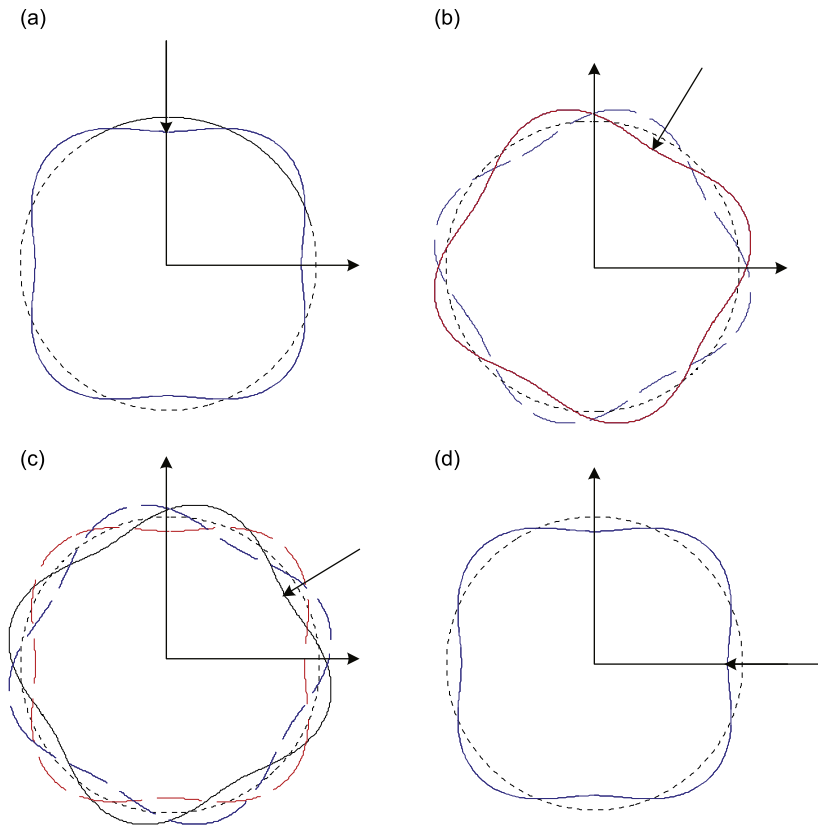

Fig. 3. Wave forms set up by travelling point load, forward travelling waves —, and backward travelling waves ----.

factor changing each time is the forcing function. Evaluation of the generalised force vector for each case will allow easy evaluation of each loading case. A new subscript index preceding the forcing function will be introduced to distinguish the forcing term for each of the specific cases that follow.

### 5.1. Magnitude varying, moving point load (1)

The forcing functions for a harmonically varying moving point load, expressed as a Dirac delta function, where  $F_3$ ,  $F_\theta$  are the maximum force magnitudes per unit width in the transverse and tangential directions respectively, are as follows:

$${}_1q_3 = -\left(\frac{F_3}{R}\right)\delta(\theta - \Omega t)\cos(\omega t - \gamma) \tag{5.1}$$

$${}_1q_\theta = -\left(\frac{F_\theta}{R}\right)\delta(\theta - \Omega t)\cos(\omega t - \gamma) \tag{5.2}$$

These can be expressed in terms of complex exponentials as

$${}_1q_3 = -\left(\frac{F_3}{2R}\right)[\delta(\theta - \Omega t)e^{j(\omega t - \gamma)} + \delta(\theta - \Omega t)e^{-j(\omega t - \gamma)}] \tag{5.3}$$

$${}_1q_\theta = -\left(\frac{F_\theta}{2R}\right)[\delta(\theta - \Omega t)e^{j(\omega t - \gamma)} + \delta(\theta - \Omega t)e^{-j(\omega t - \gamma)}] \tag{5.4}$$

Substitution of Eq. (5.3) into Eq. (3.5) results in

$${}_1Q_3 = \frac{1}{\rho h N_{nk}} \int_0^{2\pi} -\left(\frac{F_3}{2R}\right) [\delta(\theta - \Omega t) e^{j(\omega t - \gamma)} e^{-jn\theta} + \delta(\theta - \Omega t) e^{-j(\omega t - \gamma)} e^{-jn\theta}] R d\theta \tag{5.5}$$

$${}_1Q_3 = -\frac{F_3}{2\rho h N_{nk}} [e^{j(\omega t - \gamma)} e^{-jn\Omega t} + e^{-j(\omega t - \gamma)} e^{-jn\Omega t}] \tag{5.6}$$

Similarly it can be found from Eq. (5.4) that

$${}_1Q_\theta = \frac{jF_\theta C_{nk}}{2\rho h N_{nk}} [e^{j(\omega t - \gamma)} e^{-jn\Omega t} + e^{-j(\omega t - \gamma)} e^{-jn\Omega t}] \tag{5.7}$$

The generalised force vector may now be expressed as

$${}_1F_n = \frac{\sqrt{F_3^2 + C_{nk}^2 F_\theta^2}}{2\rho h N_{nk}} (e^{-j(n\Omega t + \omega t + \gamma + n\phi)} + e^{-j(n\Omega t - \omega t - \gamma + n\phi)}) \tag{5.8}$$

where

$$N_{nk} = 2\pi R(1 + C_{nk}^2) \tag{5.9}$$

$$n\phi = \tan^{-1}\left(\frac{F_\theta C_{nk}}{F_3}\right) \tag{5.10}$$

Solution for the radial and tangential displacement using the methods from the general solution are shown to be as follows (it can be seen that the solution is in the same general form as shown in Ref. [4]):

$${}_1u_3(\theta, t) = \text{Re} \left\{ \sum_{n=1}^{\infty} \sum_{k=1}^2 e^{jn\theta} [{}_1a_{nk} e^{-j(n\Omega t + \omega t + \gamma + n\phi + \psi_1)} + {}_1b_{nk} e^{-j(n\Omega t - \omega t - \gamma + n\phi + \psi_2)}] \right\} \tag{5.11}$$

$${}_1u_\theta(\theta, t) = \text{Re} \left\{ \sum_{n=1}^{\infty} \sum_{k=1}^2 j C_{nk} e^{-jn\theta} [{}_1a_{nk} e^{-j(n\Omega t + \omega t + \gamma + n\phi + \psi_1)} + {}_1b_{nk} e^{-j(n\Omega t - \omega t - \gamma + n\phi + \psi_2)}] \right\} \tag{5.12}$$

where  ${}_1a_{nk}, {}_1b_{nk}$  are the modal participation amplitudes and  $\psi_1, \psi_2$  are the phase lags. They are solved below as

$${}_1a_{nk} = \frac{\sqrt{F_3^2 + C_{nk}^2 F_\theta^2}}{2\rho h N_{nk} n^2 \tilde{\omega}_{nk}^2 \sqrt{[1 - ((\Omega + \omega/n)/\tilde{\omega}_{nk})^2]^2 + 4\zeta_{nk} [(\Omega + \omega/n)/\tilde{\omega}_{nk}]^2}} \tag{5.13}$$

$${}_1b_{nk} = \frac{\sqrt{F_3^2 + C_{nk}^2 F_\theta^2}}{2\rho h N_{nk} n^2 \tilde{\omega}_{nk}^2 \sqrt{[1 - ((\Omega - \omega/n)/\tilde{\omega}_{nk})^2]^2 + 4\zeta_{nk} [(\Omega - \omega/n)/\tilde{\omega}_{nk}]^2}} \tag{5.14}$$

$$\psi_1 = -\tan^{-1} \left( \frac{2\zeta_{nk} ((\Omega + \omega/n)/\tilde{\omega}_{nk})}{1 - ((\Omega + \omega/n)/\tilde{\omega}_{nk})^2} \right) \tag{5.15}$$

$$\psi_2 = -\tan^{-1} \left( \frac{2\zeta_{nk} ((\Omega - \omega/n)/\tilde{\omega}_{nk})}{1 - ((\Omega - \omega/n)/\tilde{\omega}_{nk})^2} \right) \tag{5.16}$$

Inspection of Eqs. (5.13) and (5.14), shows a resonance condition existing when

$$\begin{aligned} \tilde{\omega}_{nk} &= \Omega + \omega/n \\ \tilde{\omega}_{nk} &= \Omega - \omega/n \end{aligned} \tag{5.17}$$

or in terms of the natural frequencies of the shell

$$\begin{aligned}\omega_{nk} &= n\Omega + \omega \\ \omega_{nk} &= n\Omega - \omega\end{aligned}\tag{5.18}$$

This is in contrast to the solution put forward by Huang and Soedel [4,7] being

$$\begin{aligned}\omega_{nk} &= \omega + n\Omega \\ \omega_{nk} &= \omega - n\Omega\end{aligned}\tag{5.19}$$

Eq. (5.17) or (5.18) is a proposed amendment to the results given by Huang and Soedel [4].

The above resonances are easily recognisable as being in the form of the well-known amplitude modulated signal, displaying the characteristics at resonance of a pair of sidebands around the driving frequency  $\Omega$ , at  $\pm\omega/n$ , as would be expected.

### 5.2. Phase varying, moving point load (2)

The forcing functions for a harmonically phase varying moving point load, expressed as a Dirac delta function, are as follows:

$${}_2q_3 = -\left(\frac{F_3}{R}\right)\delta[\theta - \Omega t - \beta \cos(\omega t - \gamma)]\tag{5.20}$$

$${}_2q_\theta = -\left(\frac{F_\theta}{R}\right)\delta[\theta - \Omega t - \beta \cos(\omega t - \gamma)]\tag{5.21}$$

These can be expressed in terms of complex exponentials as

$${}_2q_3 = -\left(\frac{F_3}{R}\right)\delta\left[\theta - \Omega t - \beta\left(\frac{e^{j(\omega t - \gamma)} + e^{-j(\omega t - \gamma)}}{2}\right)\right]\tag{5.22}$$

$${}_2q_\theta = -\left(\frac{F_\theta}{R}\right)\delta\left[\theta - \Omega t - \beta\left(\frac{e^{j(\omega t - \gamma)} + e^{-j(\omega t - \gamma)}}{2}\right)\right]\tag{5.23}$$

Substitution of Eq. (5.22) into Eq. (3.5) results in

$${}_2Q_3 = \frac{1}{\rho h N_{nk}} \int_0^{2\pi} -\left(\frac{F_3}{R}\right)\delta\left[\theta - \Omega t - \beta\left(\frac{e^{j(\omega t - \gamma)} + e^{-j(\omega t - \gamma)}}{2}\right)\right] e^{-jn\theta} R \partial\theta\tag{5.24}$$

Evaluation of the integral and simplify Eq. (5.24):

$$\begin{aligned}{}_2Q_3 &= -\frac{F_3}{\rho h N_{nk}} e^{-jn[\Omega t + \beta(e^{j(\omega t - \gamma)} + e^{-j(\omega t - \gamma)})/2]} \\ {}_2Q_3 &= -\frac{F_3 J_v(n\beta)}{\rho h N_{nk}} e^{-j[n\Omega t + v(\omega t - \gamma)]}\end{aligned}\tag{5.25}$$

where  $J_v(z)$  is the Bessel function of the first kind, and  $v$  takes all integer values between  $-\infty:\infty$ .

Similarly it can be found from Eq. (5.23) that

$${}_2Q_\theta = -\frac{j C_{nk} F_\theta J_v(n\beta)}{\rho h N_{nk}} e^{-j[n\Omega t + v(\omega t - \gamma)]}\tag{5.26}$$

The generalised force vector may now be expressed as

$${}_2F_n = \frac{J_v(n\beta)\sqrt{F_3^2 + C_{nk}^2 F_\theta^2}}{\rho h N_{nk}} (e^{-j(n\Omega t + v(\omega t - \gamma) + n\phi)})\tag{5.27}$$

Solution for radial and tangential displacements is then found to be as follows:

$${}_2u_3(\theta, t) = \text{Re} \left\{ \sum_{n=1}^{\infty} \sum_{v=-\infty}^{\infty} \sum_{k=1}^2 e^{jn\theta} [{}_2a_{nk} e^{-j(n\Omega t + v(\omega t - \gamma) + n\phi)} e^{-j{}_2\psi_1}] \right\} \tag{5.28}$$

$${}_2u_\theta(\theta, t) = \text{Re} \left\{ \sum_{n=1}^{\infty} \sum_{v=-\infty}^{\infty} \sum_{k=1}^2 jC_{nk} e^{jn\theta} [{}_2a_{nk} e^{-j(n\Omega t + v(\omega t - \gamma) + \phi)} e^{-j{}_2\psi_1}] \right\} \tag{5.29}$$

where  ${}_2a_{nk}$  is the modal participation amplitude and  ${}_2\psi_1$  is the phase lag. They are solved below as

$${}_2a_{nk} = \frac{J_v(n\beta) \sqrt{F_3^2 + C_{nk}^2 F_\theta^2}}{\rho h N_{nk} n^2 \tilde{\omega}_{nk}^2 \sqrt{[1 - ((\Omega + v\omega/n)/\tilde{\omega}_{nk})^2]^2 + 4\zeta_{nk} [((\Omega + v\omega/n)/\tilde{\omega}_{nk})^2]}} \tag{5.30}$$

$${}_2\psi_1 = -\tan^{-1} \left( \frac{2\zeta_{nk} ((\Omega + v\omega/n)/\tilde{\omega}_{nk})}{1 - ((\Omega + v\omega/n)/\tilde{\omega}_{nk})^2} \right) \tag{5.31}$$

Inspection of Eqs. (5.28) and (5.29) shows a resonance condition existing when

$$\begin{aligned} \tilde{\omega}_{nk} &= \Omega + v\omega/n \\ \tilde{\omega}_{nk} &= \Omega - v\omega/n \end{aligned} \tag{5.32}$$

Once again the solution takes the form as anticipated, of the well-known phase modulated signal, displaying the characteristics at resonance of an infinite number of sidebands around the driving frequency  $\Omega$ , spaced at  $\pm v\omega/n$  decaying with magnitude according to the first-order Bessel function  $J_v(n\beta)$ .

### 5.3. Non-uniform continuous rotating load (3)

The forcing functions for a continuous harmonically varying pressure, are as follows:

$${}_3q_3 = \text{Re} [P_3 e^{jm(\theta - \Omega t)}] \tag{5.33}$$

$${}_3q_\theta = \text{Re} [P_\theta e^{jm(\theta - \Omega t)}] \tag{5.34}$$

Substitution of Eq. (5.33) into Eq. (3.5) results in

$$\begin{aligned} {}_3Q_3 &= \frac{1}{\rho h N_{nk}} \int_0^{2\pi} P_3 e^{jm(\theta - \Omega t)} e^{-jn\theta} R \partial \theta \\ {}_3Q_3 &= \frac{P_3 \text{Re}^{-jm\Omega t}}{\rho h N_{nk}} \int_0^{2\pi} e^{j(m-n)\theta} \partial \theta \end{aligned} \tag{5.35}$$

Noting Eq. (5.35) is only valid for  $m = n$ , which gives a solution of

$${}_3Q_3 = \frac{2\pi P_3 \text{Re}^{-jm\Omega t}}{\rho h N_{mk}} \tag{5.36}$$

Similarly it can be found from Eq. (5.34) that

$${}_3Q_\theta = \frac{j2\pi P_\theta C_{mk} \text{Re}^{-jm\Omega t}}{\rho h N_{mk}} \tag{5.37}$$

The generalised force vector may now be expressed as

$${}_3F_m = \frac{2\pi R \sqrt{P_3^2 + P_\theta^2 C_{mk}^2}}{\rho h N_{mk}} e^{-jm(\Omega t + \phi)} \tag{5.38}$$

Solution for radial and tangential displacements is then found to be as follows:

$${}_3u_3 = \operatorname{Re} \left\{ \sum_{k=1}^2 e^{jm\theta} a_{mk} e^{-jm(\Omega t + \phi)} e^{-j {}_3\psi_1} \right\} \quad (5.39)$$

$${}_3u_\theta = \operatorname{Re} \left\{ \sum_{k=1}^2 j C_{mk} e^{jm\theta} a_{mk} e^{-jm(\Omega t + \phi)} e^{-j {}_3\psi_1} \right\} \quad (5.40)$$

where  ${}_3a_{mk}$  is the modal participation amplitude and  ${}_3\psi_1$  is the phase lag, they are solved below as

$${}_3a_{mk} = \frac{2\pi R \sqrt{P_3^2 + C_{mk}^2 P_\theta^2}}{\rho h N_{mk} n^2 \tilde{\omega}_{mk}^2 \sqrt{[1 - (\Omega/\tilde{\omega}_{mk})^2]^2 + 4\zeta_{mk}^2 (\Omega/\tilde{\omega}_{mk})^2}} \quad (5.41)$$

$${}_3\psi_1 = -\tan^{-1} \left( \frac{2\zeta_{mk} (\Omega/\tilde{\omega}_{mk})}{1 - (\Omega/\tilde{\omega}_{mk})^2} \right) \quad (5.42)$$

Inspection of Eqs. (5.39) and (5.40), shows a resonance condition existing when

$$\tilde{\omega}_{mk} = \Omega \quad (5.43)$$

The above resonance condition shows that only a single mode is excited by a continuous harmonically varying rotating pressure on a circular ring. A useful result of this would be that any rotating pressure field could be made of a Fourier expansion of rotating sinusoidal waves and the response made up from a sum of the above solutions for each frequency.

## 6. Conclusions

Study of the response of shells under moving loads has received only a small amount of research interest to date, but the increasing speeds, machine complexity, expanding signal processing techniques and the relentless struggle for better analysis of systems has led to this paper consolidating the current state of knowledge in this field, for further use in system response with shells under this type of loading.

A general discussion of the unique resonant phenomenon shells undergo when a moving load is applied was expanded and presented in depth for the first time. It was found that the difference between mode shapes and natural frequencies for a stationary ring under a spatially stationary load, as opposed to a moving load on a shell, was due to the existence of only forward travelling waves for quasi-stationary mode shapes. This also leads to a major difference in how the resonance frequencies are related to mode number for quasi-stationary mode shapes, with an asymptotic convergence to a single frequency of resonance for all mode shapes of compression type modes. The physical explanation of the quasi-stationary mode shapes from a moving point load was described, showing qualitatively that a transient response is present up until the point where the load has travelled around the shell's circumference a distance of two-thirds of the wavelength of the lowest mode shape of interest.

The solution for quasi-stationary modes was undertaken as a unique problem set, with different mode shapes, using complex exponentials, as an alternative to normal modal analysis, to help aid the solution formation.

Specific solutions for a moving point load harmonically varying, phase varying and a harmonically distributed load were also solved in the correct form for the first time. The form of the results for the specific solutions show what would be expected, with the analogous amplitude and phase modulated signals having resonance conditions modulated by a pair and infinite series of sidebands, respectively, around the centre resonance of  $\tilde{\omega}_{nk} = \omega_{nk}/n$ . The result for a moving harmonically distributed load showed that only a single mode shape is excited.

## References

- [1] A.E.H. Love, *A Treatise on the Mathematical Theory of Elasticity*, 4th ed., Dover Publications, New York, 1927 xviii, p. 643.
- [2] G.F. Carrier, On vibrations of rotating ring, *Brown University—Quarterly of Applied Mathematics* 3 (3) (1945) 235–245.
- [3] S.C. Huang, W. Soedel, Effects of Coriolis acceleration on the free and forced in-plane vibrations of rotating rings on elastic foundation, *Journal of Sound and Vibration* 115 (2) (1987) 253–274.
- [4] S.C. Huang, W. Soedel, Response of rotating rings to harmonic and periodic loading and comparison with the inverted problem, *Journal of Sound and Vibration* 118 (2) (1987) 253–270.
- [5] E.N.K. Liao, P.G. Kessel, Response of pressurized cylindrical shells subjected to moving loads, *Journal of Applied Mechanics, Transactions of ASME* 39 Ser E (1) (1972) 227–234.
- [6] W. Soedel, *Vibrations of Shells and Plates*, second ed., Marcel Dekker, New York, 1993 xix, p. 470.
- [7] S.-C. Huang, W. Soedel, On the forced vibration of simply supported rotating cylindrical shells, *Journal of the Acoustical Society of America* 84 (1) (1988) 275–285.
- [8] A.V. Metrikine, M.V. Tochilin, Steady-state vibrations of an elastic ring under a moving load, *Journal of Sound and Vibration* 232 (3) (2000) 511–524.
- [9] J.R. Hartin, E. Quandt, Forced response of a cylindrical shell due to a rotating harmonic internal pressure loading, *Active Control of Vibration and Noise, ASME, DE* 75 (1994) 337–342.
- [10] F.M. Detinko, Non-linear vibration and stability of a ring under non-uniform rotating load, *International Journal of Non-Linear Mechanics* 33 (1) (1998) 59–65.
- [11] S.V. Canchi, R.G. Parker, Parametric instability of a circular ring subjected to moving springs, *Journal of Sound and Vibration* 293 (1–2) (2006) 360–379.
- [12] S.V. Canchi, R.G. Parker, Parametric instability of a rotating circular ring with moving time-varying springs, *Journal of Vibration and Acoustics, Transactions of the ASME* 128 (2) (2006) 231–243.
- [13] G.L. Forbes, R.B. Randall, Simulated gas turbine casing response to rotor blade pressure excitation, *Fifth Australasian Congress on Applied Mechanics*, Brisbane, Australia, 2007.
- [14] G.L. Forbes, R.B. Randall, Separation of excitation forces from simulated gas turbine casing response measurements, *EURODYN 2008*, Southampton, UK, 2008.
- [15] R. Penneon, A. Berry, F. Laville, Vibration and sound radiation of a cylindrical shell under a circumferentially moving load, *Journal of the Acoustical Society of America* 98 (4) (1995) 2165.
- [16] M.S. Qatu, *Vibration of Laminated Shells and Plates*, Elsevier, Amsterdam, London, 2004, p. xvi, 409.
- [17] A.W. Leissa, et al., Vibration of shells. 1993, [United States]: Acoustical Society of America through the American Institute of Physics, viii, p. 428.
- [18] S. Timoshenko, Method of analysis of statical and dynamical stresses in rail, *International Congress for Applied Mechanics—Proceedings*, 1926, pp. 1–12.
- [19] L. Fryba, *Vibration of Solids and Structures Under Moving Loads*, third ed., Thomas Telford, London, 1999, p. xxvii, 494.