

NOTES.

The Colour produced by the Action of Light on Concentrated Solutions of Ammonium Thiocyanate. By EMIL ALPHONSE WERNER and KENNETH CLAUDE BAILEY.

THE well-known pink coloration which develops in ammonium thiocyanate, or in a concentrated aqueous solution of the salt, on exposure to light has been recently investigated by Holmes (this vol., p. 1690), who is disposed to attribute it to insoluble sulphur aggregates of sub-microscopic size produced in the irreversible change $\text{NH}_4\text{SCN} \rightarrow \text{NH}_4\text{CN} + \text{S (sol)}$.

In view of the following facts, however, it seems probable that the dissociation of the salt into ammonia and thiocyanic acid is the phenomenon which is primarily responsible for the result.

(a) Ammonium thiocyanate, or a strong solution thereof, which has developed a pink colour invariably shows an acid reaction, and neutralisation with ammonia causes the pink coloration to disappear.

(b) A colourless solution of potassium thiocyanate, which yields no colour to ether or amyl alcohol, gives, on addition of hydrochloric acid, a pink colour which is readily extracted from the solution by these solvents, a phenomenon already discussed by one of us (Bailey, *Proc. Roy. Irish Acad.*, 1924, **37**, 6).

(c) The coloration produced by insolation of ammonium thiocyanate appears to behave in a similar manner to the pink coloration produced as in (b). It can be extracted from aqueous solution by ether, but is not removed by carbon disulphide or benzene, solvents which might be expected to remove sulphur and thus extract or destroy the colour if due to the cause advanced by Holmes.

The solvents—amyl, butyl, and benzyl alcohols, amyl acetate, ether, diphenyl ether, and nitrobenzene—which gave a pink extract of thiocyanic acid from an aqueous solution of potassium thiocyanate acidified with hydrochloric acid all contain oxygen, whereas no extraction was obtained with amylene, ethylene dibromide, chloroform, carbon tetrachloride, carbon disulphide, benzyl chloride, benzene, toluene, or turpentine.

(d) A pink solution of thiocyanic acid in amyl alcohol, on exposure in a glass vessel to the action of light for a long time, gradually lost its colour, a precipitate was produced, and hydrocyanic acid was detected in the liquid. The development of hydrocyanic acid occurs, therefore, at a second stage in the process.

(e) Aqueous solutions of thiosulphuric acid and the thionic acids liberate colloidal sulphur but show no pink coloration.

The suggestion has been made (Bailey, *loc. cit.*) that the disappearance of colour in the dark or on heating can be explained in one of two ways. An equilibrium may exist between tautomeric forms of thiocyanic acid, of which the colourless form alone is stable at high temperatures and in the dark, or else a coloured complex, dissociated by heat or in the dark, is formed between the acid and the oxygen-containing solvent. The existence of a compound composed of equal numbers of molecules of thiocyanic acid and ether has been noted by Klason (*J. pr. Chem.*, 1887, **35**, 400). The possibility that the pink colour may be due to traces of iron cannot be ruled out, as is clear from the results obtained by Parenti (*Gazzetta*, 1889, **19**, 175) on repeating the earlier work of Miquel (*Bull. Soc. chim.*, 1876, **26**, 442). This point is being investigated.—TRINITY COLLEGE, DUBLIN. [Received, September 10th, 1926.]

The Condensation of Quinaldine with m-Nitrobenzaldehyde. By THOMAS WESTON JOHNS TAYLOR and CHARLES POWYS WOODHOUSE.

If quinaldine and *m*-nitrobenzaldehyde are condensed together by heating on the water-bath either with or without addition of zinc chloride, the sole product is 2-*m*-nitrostyrylquinoline, which crystallises from alcohol in yellow needles, m. p. 156° (Found: C, 74.0; H, 4.65; N, 9.83; *M*, in nitrobenzene, 272.5; in ethylene dibromide, 289.7. Calc.: C, 73.9; H, 4.3; N, 10.1%; *M*, 276). The picrate melts at 261° (decomp.). The compound is unaffected by boiling with acetic anhydride.

The observations of Wartanian (*Ber.*, 1890, **23**, 3645) as to the physical properties of this compound and as to the simultaneous formation in the above condensation of 2- β -hydroxy- β -*m*-nitrophenylethylquinoline are incorrect.

The styryl compound unites with bromine in chloroform solution to give a dibromide, which can be recrystallised from alcohol; m. p. 170—171° (Found: Br, 36.4. Calc.: Br, 36.7%).—THE DYSON PERRINS LABORATORY, OXFORD. [Received, June 9th, 1926.]

Arrangement for Alternating Current Electrolysis. By HENRY J. S. SAND and WILLIAM V. LLOYD.

EXPERIMENTS on superposing an alternating on a continuous current are often of considerable interest and importance (*e.g.*, Allmand and Barklie, *Trans. Faraday Soc.*, 1926, **22**, 35, which also gives further references). In many electrochemical laboratories the alternating current and the measuring instruments required for such experiments are not available. Moreover, it may be desirable

to measure electrode potentials separately during each pulse of the current, a possibility which, so far as we are aware, has hitherto not been realised (Glasstone, *J. Amer. Chem. Soc.*, 1925, 47, 940).

We describe the following circuit in the hope that it may be as useful to others as it has been to ourselves. It makes use of a source of continuous current and a revolving three-point commutator. Successive alternating pulses of arbitrarily adjustable value may be obtained and separately measured. The ammeter may be a direct-current instrument. Thus all the electrolytic effects obtainable by superposing alternating on direct current may be produced, the sinusoidal character of the alternating current being of no importance in such experiments.

FIG. 1.

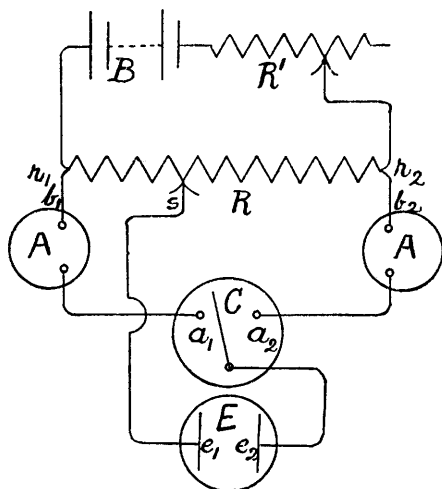

The accompanying figure is sufficiently explanatory. A suitable voltage can be impressed on the ends r_1 and r_2 of the sliding rheostat, R , by means of the battery, B , and the back resistance, R' . The slider s is connected to one of the electrodes e_1 of the cell E , the other electrode, e_2 , being connected through the commutator, C , alternately *via* the points a_1, b_1 or a_2, b_2 , respectively, to the

two ends, r_1 and r_2 , of the sliding rheostat. The branches $a_1 b_1$ and $a_2 b_2$ may each include an ammeter, A , but as a rule one ammeter suffices if it be successively interposed in either branch as required. (This can be easily arranged by means of a combined double-pole switch and short-circuiting key such as can be improvised from a Pohl commutator.) If two uni-directional pulses of different magnitude, corresponding to a feeble alternating current superposed on a more powerful continuous one, are required, they can be readily obtained by altering, say, the connexions $e_1 s$ and $b_2 r_2$ into $e_1 r_2$ and $b_2 s$. By the use of suitably designed commutators, the time during which successive pulses are in operation may be made unequal.

Where electrode potentials during each pulse are to be measured, a second two-point revolving commutator is mounted on the same shaft as the first. The auxiliary electrode is best permanently connected to one terminal of the potentiometer, the working

electrode under examination being connected through the two-point commutator to the other terminal of the potentiometer. The construction of the two-point commutator should be such that connexion is only made during a slightly shorter interval than that during which the pulse to be examined flows through the cell. The well-known Whetham double commutator can be readily adapted to the purpose, three unnecessary brushes being removed.—SIR JOHN CASS TECHNICAL INSTITUTE, E.C. 3. [*Received, September 16th, 1926.*]
