

CXIV.—*The Glow of Arsenic.*

By HARRY JULIUS EMELÉUS.

THE glow of arsenic is a feebly luminous and relatively cool flame which is observed in the oxidation of this element just below the ignition point. This mode of combustion differs from normal burning in that heat must be supplied to maintain the flame, which is of such a low intensity that it can be seen only in a dark room. According to Joubert (*Compt. rend.*, 1874, **78**, 1853) the oxygen pressure has to be below a certain value for the occurrence of this phenomenon. Bloch (*ibid.*, 1909, **149**, 775) found the product of the glow to be arsenic trioxide mixed with a little pentoxide. He could detect neither ionisation nor the presence of ozone in the gas passing away from the flame. The experiments described below were made to

investigate the "glow pressure" effect mentioned by Joubert (*loc. cit.*), and to compare this and other features of the oxidation of arsenic with the glow of phosphorus.

Two methods were used. In the first, the rate of pressure change in a closed system, resulting from the condensation of the arsenic trioxide formed, was observed. It was found that during the non-luminous stage of the reaction there was a slow absorption of oxygen, but that when the arsenic was glowing the rate of decrease of pressure was much greater. Secondly, visual observations were made of the temperature at which arsenic began to glow on being slowly heated in a stream of gas under various conditions.

The arsenic was freed from oxide by volatilising the latter in a vacuum at 280°. The element itself was then sublimed at 400°,

and the product broken up and sieved between meshes 20—8.

About 3 g. were packed round a thermometer bulb in A (Fig. 1),

and the apparatus was heated to 300° by a burner, water vapour being removed by a pump attached *via* phosphorus pentoxide guard-

tubes at C. Dry oxygen was admitted at D from a cylinder,

and the electrically heated furnace, B (10 cm. internal diameter),

adjusted to the required temperature, was raised to envelop A.

The decrease of pressure per minute was recorded as soon as a

contraction began; the pressure was then diminished by a few cm. of mercury, fresh readings were taken, and so on.

The general nature of the results was as follows. The formation of arsenic trioxide started well below 200°. At temperatures between 250° and 310° the rate of oxidation increased slightly as the pressure was decreased, the reaction being non-luminous. At a certain critical pressure—the "glow pressure"—the rate of oxidation suddenly increased, and a glow appeared near the arsenic surface. Simultaneously the temperature rose by about 7°.

Two experimentally-determined curves are shown in Fig. 2. These illustrate both the break in the oxidation rate and the influence of temperature on its position. From 6 to 10 such sets of observations could be made with one sample of arsenic, provided that this was heated in a vacuum between each set to remove oxide, and that water vapour was excluded. The presence of aqueous vapour

FIG. 1.

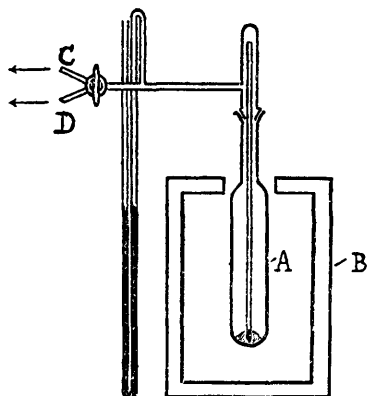

permanently retarded the reaction, probably owing to the formation of non-volatile films on the arsenic grains.

The glow pressure was found to depend both on the temperature

FIG. 2.

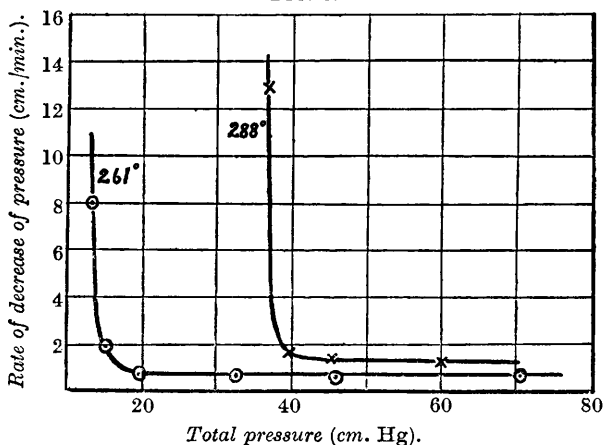

and on the length of the tube which was heated in the furnace. The curve in Fig. 3 shows a set of observations illustrating the influence of temperature (the tube was 16 cm. long and of 2.8 cm.

FIG. 3.

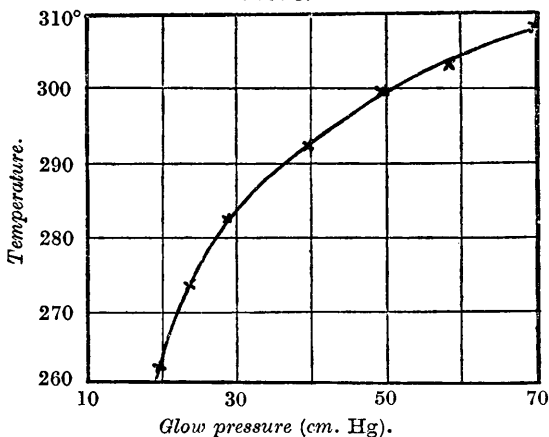

internal diameter, 6 cm. being heated in the furnace). In form, this curve corresponds with those obtained by Scharff in studying the influence of temperature on the glow pressure of phosphorus and some of its compounds (*Z. physikal. Chem.*, 1908, **62**, 179).

The length of tube heated was measured from the bottom to the sharply-defined zone where the oxide condensed. Table I shows the effect of varying this distance in a series of experiments. The same tube was used as before, the temperature being $292^{\circ} \pm 1^{\circ}$.

TABLE I.

Length of tube heated (cm.) ...	16	13	10.2	7.2	5.7
Glow pressure (cm. of mercury)	8	14	19	29	38

For different samples of arsenic the observed value of the glow pressure varied by less than 4 cm. This variation is probably due to the very large influence of the conditions of heating. A number of experiments made with oxygen-nitrogen mixtures showed that a glow pressure existed in this case also. The results were not readily compared with one another, however, owing to changes in the composition of the gas mixture during the non-luminous stage of the oxidation.

Experiments in Gas Streams.—The object of these was to compare the temperatures at which the glow started in air and in oxygen, and to find if certain vapours which inhibit the glow of phosphorus have any effect on that of arsenic. Apparatus similar to that shown in Fig. 1 was employed. The preheated gas stream was introduced by a side tube 1 cm. above the arsenic surface, and the temperature was raised slowly until a glow was observed. The main conclusions from these experiments were :

1. The temperature at which the glow appeared increased with the length of tube in the furnace, varying from 210° to 290° . The temperatures were lower than in stationary gas at the same pressure.
2. The glow occurred in oxygen at a temperature about 10° higher than in air under otherwise identical conditions.
3. No effect was produced on the glow temperature if the air used was saturated at room temperatures with carbon tetrachloride or nitrobenzene, or was diluted with 10% by volume of sulphur dioxide. All these substances inhibit the glow of phosphorus, though they are not among the most active. Many of the stronger poisons are thermally decomposed at the temperature at which arsenic glows.

The Cause of the Glow Pressure.—The foregoing experiments show that the glow of arsenic does not occur until the pressure is reduced. The cause of this is indicated in Table I, where it is shown that the greater the distance from the arsenic surface to the zone where the oxide condenses the less readily the glow occurs. From this it appears that the oxide itself hinders the reaction, this effect becoming smaller the steeper the concentration gradient which determines its removal by diffusion. This may be due to retardation of the

reaction owing to the accumulation of its product, or, alternatively, it may be ascribed to a specific inhibitory action, similar to the inhibition of the glow of phosphorus by substances such as ethylene.

The effect of reduction of pressure in promoting the glow may similarly be due to an acceleration of the removal of oxide. It is known that a substance evaporates at a greater rate at low pressures than at high, the relation between the rate of evaporation v , the total pressure P , and the partial pressure of the evaporating substance p' , being $v = c \log P/(P - p')$, where c is a constant (Stefan, *Sitzungsber. Akad. Wiss. Wien*, 1873, **68**, 385; compare also Ewan, *Phil. Mag.*, 1894, **38**, 505). The conditions in the present case are similar to those considered by Stefan. Evaluating this expression for the vapour pressure at, e.g., 291° , the relative rate of evaporation is found to increase rapidly below a certain total pressure, as shown in Table II ($p' = 6.54$ cms.).

TABLE II.

Total pressure, P (cm. Hg) ...	60	40	20	15	10	8	7
$\text{Log}_{10} P/(P - p')$	0.05	0.08	0.17	0.25	0.46	0.74	1.18

The pressure at which a rapid rate of evaporation sets in depends on the partial pressure of the oxide, and therefore on the temperature. Its variation with temperature is, moreover, similar to that of the glow pressure itself. If the above conception is correct, the production of the glow of arsenic on reducing the pressure may be considered as due, at least in part, to an acceleration of the removal of oxide, and hence of the reaction itself.

Analogy with the Glow of Phosphorus.—The chemical similarity of arsenic and phosphorus extends to their phosphorescent flames. In neither case does the luminous oxidation in oxygen start until the pressure is reduced. In each instance, the higher the temperature the less is the requisite pressure reduction. The non-luminous reaction preceding the glow is, however, much more vigorous for arsenic than for phosphorus (Rayleigh, *Proc. Roy. Soc.*, 1924, *A*, **106**, 1), and the experiments indicated that the ease of removal of the oxide so formed largely determined the occurrence of the glow. No corresponding phenomenon is known in the oxidation of phosphorus.

The glow of phosphorus occurs at considerably higher temperatures in oxygen than in air. In the case of arsenic, these two temperatures were found to be more nearly the same, and the difference could be ascribed to a larger formation of oxide in oxygen. Three substances which inhibit the glow of phosphorus are without influence on that of arsenic. It is possible, however, that others will be found capable of inhibiting the latter reaction also.

The author wishes to express his gratitude to Professor H. B. Baker, in whose laboratory these experiments were carried out, for his interest and advice. The research has been conducted during the tenure of an 1851 Senior Studentship.

IMPERIAL COLLEGE OF SCIENCE AND TECHNOLOGY,

LONDON, S.W. 7.

[*Received, January 18th, 1927.*]
