

CCXXII.—*A New Form of Thermostat and Observation Tubes for Polarimetric Work.*

By THOMAS STEWART PATTERSON.

IN polarimetric investigation, it is of very great importance to maintain a steady known temperature while the rotation of the active substance is being observed. The author in the course of his work has tried various forms of apparatus designed for this purpose, and some fifteen years ago adopted one which, since it has been found to give accurate results and to be easy to manipulate, may be of use to others engaged in similar work.

The polarimeter tube is so placed as to be in direct contact with the water in the thermostat. The upper part, I, of the accompanying figure gives a general idea of the whole apparatus. The polarimeter tube, A, has attached to it a side tube, B, reaching above the level of the liquid in the thermostat. The glass end discs may be cemented to the polarimeter tube or may be fixed in position by means of pieces of rubber tubing marked C in the lower, more detailed part of the figure. These act partly to prevent ingress of water into the tube or exit of material from it, and serve also, by being turned over the end of the cover glass, as washers to take up the pressure exerted by the brass end pieces, DD, of which there is one at each end. These are fastened together by means of the brass rods, FF, which have a small knob at one end and a screw at the other; the latter fits into a corresponding screw in one of the discs. These are really arranged as in the upper sketch, but the lower sketch shows the

details of each end. These rods just pass easily through holes in two collars, T T, which thus serve to keep the end plates, D D, in position. To the flanges, D D, are brazed brass tubes, G G. When the apparatus is in use, these brass tubes are passed through rubber bungs which fit into collars in the wall, L, of the bath, as shown at K K.

In carrying out an observation, the thermostat is emptied of liquid, and the polarimeter tube in its support of flanges and rods, either filled with the active liquid or empty, is introduced through the rubber bungs to appear as shown in I, an operation easily

FIG. 1.

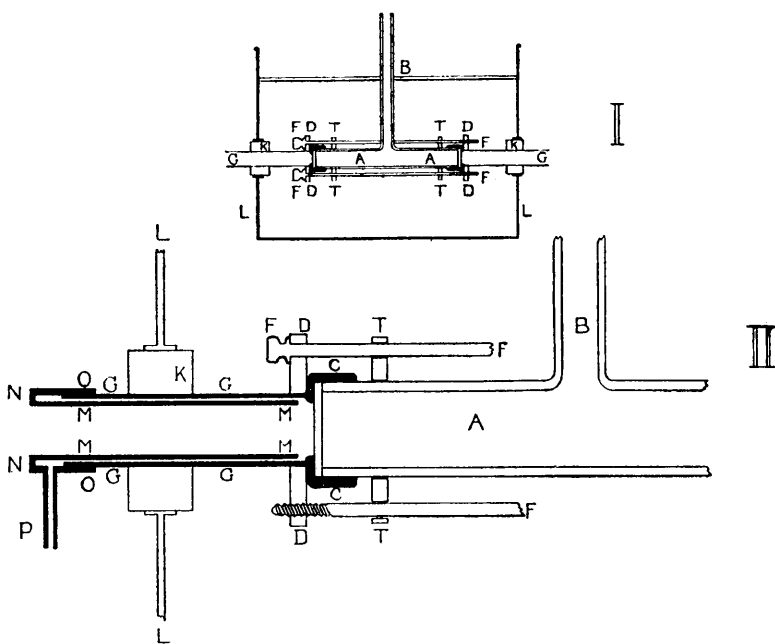

performed. The active liquid may now be introduced into the tube, if this has not already been done, and the thermostat filled with water, upon which, preferably, there should float a layer of oil.

The temperature of the thermostat may be controlled by any suitable form of adjustable thermo-regulator, that used in this laboratory being one designed by the author (*J. Soc. Chem. Ind.*, 1902, 21, 456). The liquid in the thermostat is also, in most cases, mechanically stirred, but this is not necessary for temperatures of 0°, 100°, and that of the atmosphere. By means of suitable screws on the legs of a quadrupod or tripod stand, the thermostat is adjusted so that the axis of the tube coincides accurately with the axis of the polarimeter.

Owing to the fact that there is direct contact between the glass of the polarimeter tube and the water in the thermostat, the temperature in the polarimeter tube becomes constant very rapidly; and since, between observations, the water in the thermostat may be replaced by water which, previously, has been heated very near the desired temperature, the time which must be allowed to elapse before a new temperature is established is reduced to a minimum. The variation of the temperature during the time required for the observations is very small indeed and the temperature may be maintained within about one-tenth of a degree of any desired value for long periods.

The temperature of boiling water is very easy to adjust too, especially when a layer of oil is used. A very small flame is sufficient to keep the water in the thermostat in ebullition and the temperature in the polarimeter tube is then exceedingly steady.

This is the upper limit of temperature at which we have used the apparatus, but it would not be difficult to adapt it for higher temperatures, by using concentrated potassium carbonate solution, for example, instead of water. For temperatures above 100° , we use an oil thermostat with an air chamber in which the tube is heated.

The apparatus described, however, may be used for temperatures *below* that of the atmosphere and it is possible to obtain very constant readings at a temperature of zero, which again is, of course, a very simple one to obtain; the thermostat is filled with a slush of ground ice and water. The difficulty then arises, however, that moisture is apt to condense on the end plates of the polarimeter tubes. To get over this difficulty, various methods were tried, but ultimately one which is exceedingly effective and also very simple has been adopted. This is illustrated in II. A piece of brass tubing, M M M M, which fits into the tube G G with a clearance of, perhaps, half a millimetre, and of a length sufficient to reach to about a millimetre or two from the end plate of the polarimeter tube, is soldered by an annulus, N, to another short piece of brass tube, O O, which just slips on to the outside of the tube G G. To this tube, O, is soldered a short narrow brass tube, P. The whole part M N O P can thus easily be removed when not wanted and equally easily replaced in position when required; one such part is fitted at each end of the polarimeter tube. The little tubes P are then connected to two of the arms of a Y piece, the third arm of which, in turn, connects with a drying tower containing sulphuric acid and pumice stone, this again being connected to a gas holder containing air. When observations are to be made at a temperature below that of the atmosphere, a quite slow current of dry air intro-

duced through the tubes P passes through the narrow space between the tubes M M and G G to near the end plate of the polarimeter tube, and out through the tube M M M M. The air close to the polarimeter end plate is thus kept thoroughly dry and no moisture is deposited upon the end plate. This arrangement is surprisingly efficient and even when a freezing mixture of carbon dioxide and alcohol is used as cooling agent, which causes the whole of the apparatus quickly to be covered with ice, a perfectly clear view through the polarimeter tube may be obtained, so long as the current of air is passing.

This little piece of apparatus will be found of very considerable value, since by its means it is easy to determine rotation values at zero, which is probably the most suitable standard temperature for the expression of polarimetric results, inasmuch as it can always be easily obtained, but which hitherto has been avoided, doubtless owing to the difficulty occasioned by the condensation of moisture on the end discs.

The bath which we use is 25 cm. long by 5 broad by 17 deep and accommodates comfortably tubes 160 mm. in length.

UNIVERSITY OF GLASGOW.

[Received, June 2nd, 1927.]
