

CCLXXII.—*The Transference of Water and its Dependence on Concentration in the Electrolysis of Sodium Chloride Solutions.*

By MILLICENT TAYLOR and EDWARD WILLIAM SAWYER.

IN 1909 Washburn (*J. Amer. Chem. Soc.*, **31**, 322) published careful measurements of the changes in concentration of a non-electrolyte during the electrolytic migration of the ions of salts in aqueous solution. Assuming these changes to be due to the transport of water by the ions, he was able to calculate the total water transported during the passage of one faraday of electricity. Some doubt, however, is thrown on the significance of these results, owing to the high molecular weight of raffinose, $C_{18}H_{32}O_{16}$, which was the only reference substance found by Washburn to give concordant results.

Coehn (*Z. Elektrochem.*, 1909, **15**, 622) observed the Tyndall cone in sucrose solutions and stated that this sugar migrates in the

electric field, hence raffinose, having a much higher molecular weight than sucrose, would be expected to show this phenomenon more strongly.

Newbery (J., 1917, **111**, 487), who concludes from experiments on overvoltage that the hydration of sodium and chlorine ions is highly improbable, attributes the results obtained by Washburn to the adsorption of ions by, and consequent migration of, the large raffinose molecules, and is of the opinion that this source of uncertainty can be eliminated only by the use of a reference substance of low molecular weight.

One of us (*J. Amer. Chem. Soc.*, 1928, **50**, 3261) has pointed out that urea (carbamide), with its low molecular weight, its low dissociation constant, 1.5×10^{-14} at 25° , and its great stability when pure at the ordinary temperature, together with the ease and accuracy with which it can be estimated, constitutes an almost ideal reference substance in this type of experiment.

Washburn's experiments (*loc. cit.*) were carried out with the chlorides of sodium, potassium, lithium, and, later (*ibid.*, 1915, **37**, 694), of caesium, and in view of the small amount of water transported, the concordance of the results is remarkable. The fact remains, however, that with each salt only one complete experiment was carried out in which the weight of transported water was calculated from the composition and weight of both anode and cathode solutions; moreover, the experiment with sodium chloride as reported in the first paper was only partly successful, and although repeated in 1915, the results showed less satisfactory agreement than those obtained with the other chlorides.

In view of Newbery's conclusion, therefore, we decided in our preliminary investigation of the efficiency of urea in this type of experiment to work with sodium chloride of approximately $0.5M$ -concentration.

As the result of two complete migration experiments, we find undoubted movement of water in the direction indicated by Washburn's work. The values for the weight of water transported per faraday of electricity agree more closely among themselves than do those of Washburn, and are somewhat larger. The probable cause of this larger value is discussed below.

EXPERIMENTAL.

The migration apparatus shown in the figure is designed to afford several middle portions for analysis and to minimise disturbance due to diffusion and convection. The main features are the long distance between anode and cathode compartments, the composite nature of the middle section, and the large size of the two-way taps,

A and B, which can be closed in the thermostat immediately the electrolysis is stopped. These taps not only cut off the middle from the electrode portions, but each also encloses some 70—80 c.c. of solution, which can be withdrawn for analysis through the openings C or D. The middle section, made of silica, consists of some 18 parallel tubes of about $\frac{1}{8}$ " diameter leading at each end into a common wide tube. The object is to ensure that the middle portion shall be kept at a temperature as constant as that of the

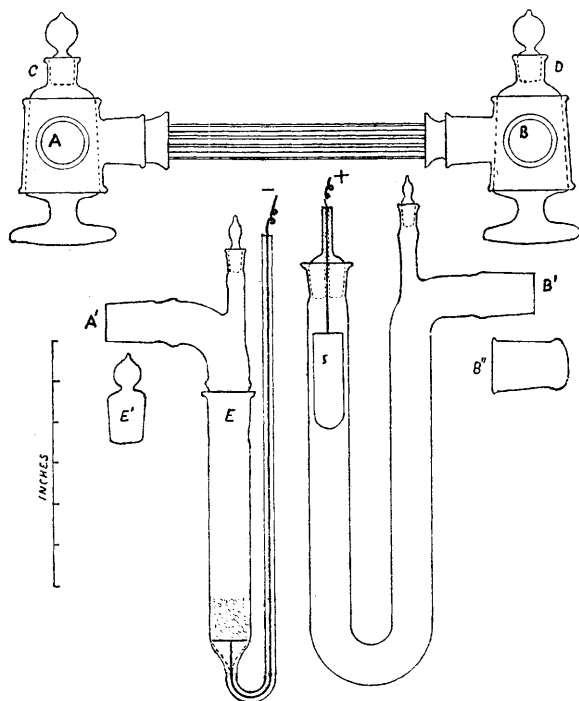

thermostat (*viz.*, $25^{\circ} \pm 0.02^{\circ}$) and to prevent convection. With the exception of the middle section, the whole apparatus is made of borosilicate glass.

This form of apparatus permits the removal of five middle portions, by the analysis of which the extent of diffusion of urea or electrolyte can be determined. Any portion differing in composition from the original solution can be included in the adjacent electrode portion. In the experiments here described, it was not found necessary to distinguish more than three middle portions, although the whole of the contained solution is included in the analytical results. This entailed weighing of each part of the apparatus, but

since any changes in composition of portions adjacent to the electrode portions were very slight, the only weights required with great accuracy were those of the anode and cathode portions.

The Electrodes.—The silver chloride cathode was prepared as described by Washburn (*loc. cit.*, 1909), except that, in view of the difficulty of complete removal of silver and silver chloride from the cathode tube after the experiment, a check was kept on its weight by precipitating a known weight of silver nitrate as chloride. Then, after transfer of the main portion of chloride with electrolyte solution to the cathode tube, the remainder was collected on a filter and estimated in the usual way. Thus the weight of silver and chloride in the cathode at the end of the experiment could be calculated.

The anode was Washburn's B type, consisting of electrolytic crystals of silver in a Soxhlet thimble.

Two silver coulomb-meters, one at each end of the migration apparatus, gave the total current passed and served to indicate the magnitude of any electrical leak. In the first experiment, when such leak occurred, it was detected by the much more sensitive method of earthing the metal edge of the thermostat through the tongue and a moist finger. The results of the first experiment, although qualitatively interesting, were discarded on account of this leak.

Materials.—The electrolytic solution was made with distilled water of specific conductivity 0.9×10^{-6} mho at 25° .

The urea (Kahlbaum's purest), after being finely ground and dried for about 12 hours at 95 – 100° , melted at 133.0 – 133.5° . Its $0.11M$ -solution in the above conductivity water was neutral to litmus and possessed a specific conductivity of 1.8×10^{-6} mho.

The sodium chloride, also Kahlbaum's pure material, was ignited in platinum immediately before being weighed, and with the urea was dissolved in a weighed quantity of conductivity water. The solution was kept in well-stoppered Jena bottles, the vaselin used on the stoppers having been repeatedly extracted with boiling distilled water.

The Migration Experiment.—After careful weighing of the anode and cathode compartments together with their respective caps and stoppers, the silver anode, and the cathode plate of silver coated with silver chloride were put in position, the silver chloride was added, and after all internal joints had been greased lightly with vaselin, the whole apparatus was put in position, filled with solution, and all external joints were coated with paraffin. The apparatus was then immersed in the thermostat, the only projecting parts being the narrow glass tubes carrying the anode and cathode leading wires.

When the temperature of the thermostat became steady, a current of about 80 milliamps. was passed for 14 hours; the current was then stopped, the taps A and B were closed, the whole apparatus was removed on its stand from the thermostat, and the portions of solution between the electrode portions and the taps A and B were transferred to weighed flasks by means of weighed pipettes. As care was taken to avoid deep immersion of these pipettes during withdrawal of the solution, and as the total weight of liquid clinging to either of them, internally and externally after use, was about 0.15 g., the error due to loss of externally clinging liquid was negligible. This was all the more the case, since if those portions differed at all in composition from the original solution the difference was very slight.

The electrode compartments fitted with their special caps and stoppers are dried, kept for about an hour in the balance case, and weighed with the usual precautions. The caked silver chloride cathode is thoroughly broken up by means of a stout, weighed silver wire, which after use is bent back on itself and left in the electrode compartment. Both solutions are then left for several days in contact with the electrode, the whole apparatus being turned over and shaken at intervals. Before withdrawal of the solutions for analysis the total weight is again checked, and every solution is tested for neutrality to litmus.

Method of Analysis.—The urea was estimated gravimetrically as described by Taylor (*J. Amer. Chem. Soc.*, 1928, **50**, 3261), being digested in a silica flask under pressure with slight excess of standard hydrochloric acid, subsequently neutralised with standard caustic soda. To estimate the sodium chloride, the neutral solution was transferred to a weighed platinum dish, and evaporated in a steam-oven at about 60°. During evaporation, the dish was covered by a platinum lid supported about 1 cm. above its edge. After evaporation to dryness, the lid was firmly fitted on to the dish, which was gradually heated in an air oven up to about 150°. Finally, the lid being still kept on, the dish was heated from above downwards with a naked flame till it attained constant weight.

The small known weight of salt formed by neutralisation of the acid was subtracted from the total weight of salt in the dish, after correction of the latter for buoyancy of the air. The original solution was analysed in the same way and changes in concentration were determined by a comparison of the initial and final analytical values.

Since the quantity of rinsing water used in the above process was somewhat large, the tendency was to give a value for the sodium chloride which was about 0.1% too high (see Table I, Expt. 2).

To avoid this, a modification was introduced in Expt. 3 which reduced the quantity of rinsing water to about 10 c.c. Before neutralisation of the acid in the digestion flask, very small quantities of conductivity water were repeatedly drawn in through the side tube. After neutralisation, the side tube was dried in a current of air scrubbed through cotton wool, and its cleanliness ascertained by inspection. Uniformity of the liquid in the flask was ensured by careful shaking, and after being weighed, the contained liquid was poured into the evaporating dish, and the flask and clinging liquid were immediately weighed again.

By subsequently weighing the clean dry flask, the fraction of the total liquid evaporated was determined. Since the standard acid was prepared by the method of Hulett and Bonner (*J. Amer. Chem. Soc.*, 1909, **31**, 390), whose silver chloride analyses of a given acid solution differ by about 0.1%, the analytical values for the original urea solution as compared with the quantity of material weighed out do not afford any criterion, within 0.1%, for the purity of the urea. The suitability of the latter for the purpose of these experiments is shown by its melting point, the conductivity of its solution, and the blank migration experiment. To avoid the magnified influence of any uncertainty regarding the standard acid on differences of concentration before and after migration, the same standard acid solution was used throughout all the analyses in any one experiment, and its concentration was checked against that of the original urea solution at the beginning and end of the analytical determinations.

Calibrated weights were used and all weighings were corrected for buoyancy of the air.

Results.

Blank Experiment.—In a blank experiment to determine the migration of urea alone in an electric field the apparatus was provided with a silver spiral anode and with a cathode consisting of a silver plate thickly coated with silver chloride as described by Washburn (*loc. cit.*). After being filled with approximately 0.1*M*-urea solution, the apparatus was put into the thermostat, the two silver voltmeters were placed in the circuit, and a *P.D.* of 210 volts was applied for 21 hours. At the end of this time

1 g. of anode	solution contained	0.0059632 g. of urea,
1 g. of cathode	„ „	0.0059621 „ „ ,
1 g. of middle	„ „	0.0059613 „ „ ;

whereas 1 g. of the original solution had contained 0.0059583 g. of urea (as weighed) or 0.0059612 g. (by analysis). Also, 0.0027 g. and 0.0025 g. of silver had been deposited respectively in the anode and the cathode voltameter.

These values leave no doubt as to the suitability of urea as a non-electrolytic reference substance, and also confirm the absence of electrical leak and of electro-osmotic effect.

Migration Experiments.—In all these experiments,

E.M.F. applied = 80 volts;
 average current = 0.08 amp.;
 duration of run = about 14 hours.

TABLE I.

Approximate composition of all solutions: NaCl = 0.5*M*;
 Urea = 0.1*M*.

Accurate weight compositions of solutions before electrolysis:
 100 G. of solution contain:

<i>Expt. 2.</i>	NaCl, g.	Urea, g.	<i>Expt. 3.</i>	NaCl, g.	Urea, g.
As made up	2.9334	0.58656	As made up	2.8859	0.60037
By analysis (1)	2.9359	0.58595	By analysis (1)	2.8870	0.60048
(2)	2.9359	0.58603	(2)	2.8872	0.60038
Analytical mean =	2.9359	0.58599	Analytical mean =	2.8871	0.60043

TABLE II.

Composition and Total Weight of All Portions.

Weight of Portion.	NaCl, Urea,		Total weight of	
	g./100 g. of solution.	of solution.	solution, g.	NaCl, g. Urea, g.
Experiment 2.				
Original	2.9359	0.58599		
Anode	2.3151	0.59357	141.984	3.2871 0.84277
Anode middle	2.9333	0.58649	117.419	3.4443 0.68865
Middle	2.9319	0.58534	226.308	6.6351 1.32468
Cathode middle ...	2.9431	0.58666	55.329	1.6284 0.32459
Cathode	4.4661	0.56959	57.712	2.5775 0.32872
			Total =	598.752 17.572 ₄ 3.5094 ₁
As calculated from original composition,				
			598.752 g. of solution contain	17.579 3.5086
Experiment 3.				
Original	2.8871	0.60042		
Anode	2.1860	0.60907	128.127	2.8008 0.78038
Anode middle	2.8849	0.60050	127.688	3.6837 0.76676
Middle	2.8856	0.60045	163.090	4.7061 0.97928
Cathode middle ...	2.8864	0.59966	122.281	3.5295 0.73327
Cathode	4.2105	0.58625	68.978	2.9043 0.40438
			Total =	610.164 17.624 ₄ 3.6640 ₇
As calculated from original composition,				
			610.164 g. of solution contain	17.616 ₁ 3.6635 ₆

The values for the cathode middle solution in Expt. 3 indicate some slight diffusion between that and the cathode solution; therefore, in calculating the transport of water and of salt, both solutions are included in the cathode portion.

Tables III(a) and III(b) give, for Expts. 2 and 3 respectively, the weights of sodium chloride and water associated with a constant quantity of urea, and also the weight of sodium chloride associated with a constant quantity of water in the two electrode portions before and after electrolysis; and the weights of silver deposited in the coulomb-meters in each case are given in Table III (c).

TABLE III.

	Anode solution.		Diff., g.	Cathode solution.		Diff., g.
	Initially, g.	Finally, g.		Initially, g.	Finally, g.	
(a) Experiment 2.						
<i>Calculated to constant urea.</i>						
Urea	0.84277	0.84277		0.32872	0.32872	
NaCl	4.2224	3.2871	-0.9353	1.6470	2.5775	+0.9305
H ₂ O	138.755	137.854	-0.901	54.121	54.806	+0.685
<i>Calculated to constant water.</i>						
H ₂ O	137.854	137.854		54.806	54.806	
NaCl	4.1950	3.2871	-0.9079	1.6678	2.5775	+0.9097
(b) Experiment 3.						
<i>Calculated to constant urea.</i>						
Urea	0.78038	0.78038		1.13766	1.13766	
NaCl	3.7524	2.8008	-0.9516	5.4706	6.4338	+0.9632
H ₂ O	125.440	124.546	-0.894	182.869	183.688	+0.819
<i>Calculated to constant water.</i>						
H ₂ O	124.546	124.546		183.688	183.688	
NaCl	3.7257	2.8008	-0.9249	5.4949	6.4338	+0.9389
(c) Weight of silver deposited in coulomb-meters :						
	Expt. 2.			Expt. 3.		
Anode	4.5025 g. = 0.041736 equiv.			4.6271 g. = 0.042891 equiv.		
Cathode ...	4.5025 g. = 0.041736 ,,			4.6270 g. = 0.042890 ,,		

From the values obtained in Table III, the equivalents of water (n_w) and of salt (n_s) transported are calculated, also the true transport numbers, T_{Na} and T_{Cl} , of kation and anion respectively, and by calculating the salt transported on the assumption that the weight of water in each electrode portion is constant, the ordinary or Hittorf transference numbers (T_{Na}^H , T_{Cl}^H) are obtained. These values, together with the number (n_w^k) of g.-mols. of water transported per faraday and the number n_w/n_s of g.-mols. of water per g.-mol. of salt transported are collected in Table IV.

The details of Expt. 1 are not included, as the cathode coulomb-meter disclosed a loss of 3% of the total current. The number of g.-mols. of water transported per faraday calculated from the anode portion was -1.95, and from the cathode +0.93, giving a mean value of 1.44, in roughly quantitative agreement with the results of Expts. 2 and 3.

TABLE IV.

Temperature = $25^\circ \pm 0.02^\circ$.

	Experiment 2.			Experiment 3.			Mean of
	Anode.	Cathode.	Mean.	Anode.	Cathode.	Mean.	Expts.
n_w	0.05001	0.03802	0.0440	0.0496	0.04546	0.0476	0.0458
n_s	0.01600	0.01592	0.0160	0.01628	0.01648	0.0164	0.0162
T_{Na}^+	0.3834	0.3814	0.382 ₄	0.3795	0.3842	0.381 ₉	0.382 ₁
T_{Cl}^-	0.6166	0.6186	0.618	0.6204	0.6158	0.618	0.618
T_{Na}^H	0.3721	0.3729	0.372 ₅	0.3689	0.3745	0.371 ₇	0.372 ₁
T_{Cl}^H	0.6279	0.6271	0.627 ₅	0.6309	0.6255	0.628 ₃	0.627 ₉
n_w/n_s	3.126	2.389	2.76	3.047	2.758	2.90	2.83
$n_{w/c}^k$	-1.198	+0.9110	1.054	-1.156	+1.060	1.108	1.08

Discussion.

A consideration of the trustworthy values in the literature leads to the conclusion, not only that the direct determinations of water transport are limited to the work of Washburn and Büchbock, but also that there are very few values for ionic transport which have been determined under constant conditions.

No method involving the use of a membrane (and hence subject to a correction of uncertain magnitude for electro-osmosis) can be considered sound, except in so far as it affords results which agree with those obtained by a method free from this drawback. This is the criticism to which the results of Remy (*Fortschritte der Chemie*, 1927, **19**, II, *A* and *B*, 57) and of Baborovsky and his collaborators (*J. Chim. physique*, 1928, **25**, 480) are subject, and it applies also to the measurement of ionic transport numbers as carried out by the last-named.

Washburn's values (*loc. cit.*) for the transport of water and sodium ions at 25° in approximately *N*-solutions of sodium chloride containing about 5 g. of raffinose in 100 g. of solution are as follows :

	Anode (1909).	Anode (1915).	Cathode (1915).	Mean.
T_{Na}^+	0.383	0.377	0.376	0.379
T_{Na}^H	0.366	0.365	0.355	0.362
n_w/n_s	2.2	1.6	2.7	2.2
n_w	0.84	0.61	1.04	0.83

Noyes and Falk (*J. Amer. Chem. Soc.*, 1911, **33**, 1436), summarising all the then-available data, concluded that at 25° the transport number of the sodium ion in sodium chloride decreases with increasing concentration, and that the rate of decrease becomes considerable in concentrations higher than $0.5N$. The later accurate values of McInnes (*ibid.*, 1925, **47**, 1922) and of Dewey (*ibid.*, p. 1927), as well as the relationship of our value in $0.5N$ -solution to that of Washburn in *N*-solution, confirm this conclusion.

Notwithstanding the fact that sodium has a lower mobility than chlorine, the total effect is transport of water to the cathode;

hence it follows that the sodium ion carries more water than the chlorine ion, and any decrease in sodium-ion transport number with corresponding increase in the chlorine-ion transport would tend to decrease the quantity of water transported. Again, since this decrease in sodium-ion transport is probably in part due to the increased viscosity of the solutions (McInnes, *ibid.*, 1921, **43**, 1217), the mobility of the sodium ion, being more influenced than that of the chlorine ion by increased concentration, will probably also be more influenced by the presence of a foreign substance such as raffinose.

Hence, apart from any theory regarding the relationship between the water and the ion, the one factor whose effect on the water transport is inevitable and can be clearly foreseen, *viz.*, the relative mobilities of anion and kation, will tend in the case of sodium chloride to bring about greater transport of water in the more dilute solution, and in the solution containing the smaller weight of reference substance.

The mean transport values, *viz.*, 1.08 for water and 0.382 for the sodium ion in 0.5*N*-sodium chloride solution containing 6 g. of urea per 1000 g., as compared with Washburn's mean values of 0.83 and 0.379 respectively in *N*-solution containing 50 g. of raffinose, are completely in accordance with the above consideration. Whether this change in water transport with dilution is in part due to other factors such as change in the value of ionic hydration with concentration, cannot be decided on the present data although they throw some light on the question.

Notwithstanding the extremely divergent estimates of the actual number of water molecules associated with or influenced by any specific ion, the opinion seems to prevail that this number is only slightly, if at all, influenced by concentration (Bjerrum, *Z. anorg. Chem.*, 1920, **109**, 283; Washburn, *J. Amer. Chem. Soc.*, 1909, **31**, 346; Sugden, *J.*, 1926, 174). The Hittorf transference numbers of the ions in 0.2*N*-sodium chloride at 25° have lately been the subject of a careful investigation by Dewey (*loc. cit.*), who obtained a mean value of 0.377 for the kation, whilst the most generally accepted value of Washburn in approximately *N*-solution at the same temperature is 0.365. These two values, together with our mean, 0.372, in 0.5*N*-solution, are the only values accurately determined in this range of concentration.

Some indication of the trustworthiness of these values, and consequently of the allied true transport numbers, is given by the fact that they fall on a straight line when plotted against the logarithms of the concentrations. It is therefore interesting to use the true transport numbers as determined by Washburn and our-

selves to calculate the absolute hydration of each ion in sodium chloride on the assumption that it is independent of the concentration. If m_k and m_a are the numbers of molecules of water associated with the cation and anion respectively, and n_w^F is the number of equivalents of water transported per faraday, the following equation holds :

$$n_w^F = (1 - n)m_k - nm_a,$$

where n is the true transport number of the anion. Washburn's mean value for n_w^F for N - and our mean value for $0.5N$ -solutions being used, the equations

$$1.08 = 0.382m_k - 0.618m_a,$$

and
$$0.83 = 0.3765m_k - 0.6235m_a$$

give 16 and 29 for m_a and m_k respectively.

The sum of these numbers accounts for a large proportion of the 55.6 mols. of water in a N -solution, and is impossibly large if the water of hydration is considered as being chemically attached to the ion. Even if Washburn's value, *viz.*, 0.83, were the mean of more closely concordant values, enabling confidence to be placed in this numerical result, no conclusion could be drawn from an isolated value. It merely serves to demonstrate that several accurate determinations under varying conditions of concentration and temperature cannot fail to throw light on the nature of the association between ion and solvent.

The importance of attacking the problem by this direct method is emphasised by the widely divergent estimates of hydration numbers obtained by measurements of such phenomena as distribution, salting-out, and viscosity (Ingham, J., 1928, 1917), and the admitted difficulty in these cases of distinguishing between the effect of hydration and of independent influences such as depolymerisation of the solvent (Sugden, *loc. cit.*).

Summary.

A prolonged experiment on the migration of urea at 25.0° in aqueous solution has established lack of movement of this substance in the electric field.

Urea being used as the non-electrolytic reference substance in two complete migration experiments with $0.5N$ -sodium chloride solution, the transport of water to the cathode already detected by Washburn in N -solution has been fully confirmed. Transport values for sodium and chlorine ions, concordant amongst themselves and affording a mean value identical within the limits of experimental error with that estimated by interpolation from the most trustworthy

values for other concentrations, have been obtained for the 0.5*N*-solution.

The weight of water transported per faraday of electricity as determined by us in 0.5*N*-solution is greater than Washburn's value in *N*-solution. This result is in accordance with the observed effect of dilution on the transport numbers of the ions in sodium chloride solution.

On the assumption that the number of water molecules attached to each ion is independent of the concentration at constant temperature, the absolute value of this number is calculated. The value obtained is larger both for sodium and for chlorine ions than any values elsewhere suggested for solutions of finite dilution. Further work in this direction is proposed.

The apparatus used in these experiments is a modified form of that used in long-continued migration experiments by Professor J. W. McBain, late of Bristol University. We thank him for directing our attention to the fact that all the direct experiments hitherto carried out on the ionic transport of water are open to objection as having been carried out either with an incompletely satisfactory reference substance, or in the presence of a membrane.

THE UNIVERSITY, BRISTOL.

[Received, July 1st, 1929.]
