

46. *Determination of the Rate of Rise of Pressure in the Combustion of Some Gas-Oxygen Mixtures.*

By COLIN CAMPBELL, WILLIAM BRIAN LITTLER, and CLIFFORD WHITWORTH.

THE early experiments of Mallard and Le Chatelier (*Compt. rend.*, 1882, **95**, 1352; *J. Physique*, 1882, **1**, 173; 1885, **4**, 59) demonstrated that when certain combustible gas-air mixtures, enclosed in a cylinder, were ignited by an electric spark, the rates of rise of pressure were regular and measurable with a fair degree of accuracy. When oxygen was used instead of air, these rates were very rapid and violent compression waves were produced. These investigators were not able to measure accurately the actual pressures produced in gas-oxygen mixtures because of the rapid and very large oscillations of the pressure-recording apparatus.

Berthelot and Vieille (*Compt. rend.*, 1884, **98**, 646; *Ann. Chim. Phys.*, 1885, **4**, 13) give values for the rate of rise of pressure in the mixtures $2\text{C}_2\text{H}_2 + 5\text{O}_2$, $\text{C}_2\text{H}_4 + 3\text{O}_2$, and $\text{CH}_4 + 2\text{O}_2$ to an accuracy of 0.00001 sec. but in view of later work (e.g., Fenning, *Rep. Mem. Roy. Aer. Comm.*, 1925, 979) it is doubtful whether much reliance can be placed on these figures.

Fenning (*loc. cit.*; *Phil. Trans.*, 1926, **225**, A, 331) has measured the rate of rise of pressure of some hydrocarbon-air and carbon monoxide-air mixtures, starting from initial pressures between 1 and 5 atmospheres; and Bone (*Proc. Roy. Soc.*, 1923, **103**, A, 205; *et seq.*) has extended this work to initial pressures up to 50 atmospheres.

In connexion with some experiments on a different matter, it was necessary to determine the rate of rise of pressure, for which no data were available, for a number of mixtures containing oxygen rather than air as the supporter of combustion. The results are given in this paper.

EXPERIMENTAL.

The apparatus, made by Messrs. Baskerville and Lindsay of Manchester, was not unlike that employed by Pier (*Z. physikal. Chem.*, 1908, **62**, 385; 1909, **66**, 759), and consisted of a steel explosion cylinder (A, Fig. 1) 22.9 cm. long and 8.2 cm. in diameter; its capacity was about 1000 c.c. The metal was 1.2 cm. thick, and the apparatus was designed to stand pressures up to 100 atmospheres. Flanges, BB, were screwed on to each end of the main body of the

FIG. 1.

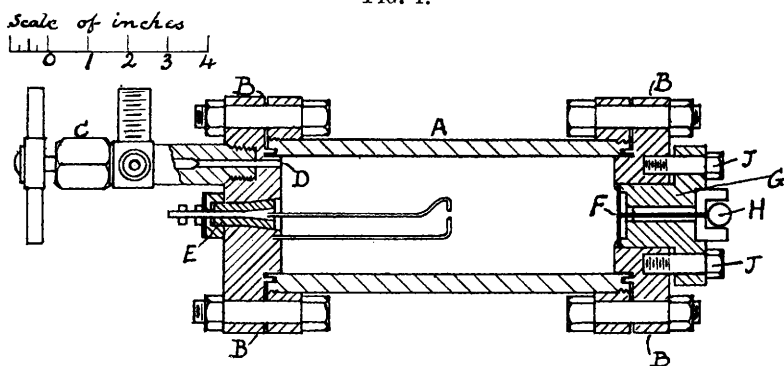

apparatus, and metal end-pieces were bolted to these flanges by means of steel bolts. Vacuum-tight joints were made by lead washers in a circular groove into which each end-piece fitted. The apparatus was evacuated and the gas mixture allowed to enter through the valve, C, which communicated with the cylinder by means of the narrow passage D (0.1 cm. diameter). Central ignition was effected across the spark gap (0.2 cm.) between the two pointed "Nichrom" wires: one of these was insulated by means of the ebonite plug, E, and the other was screwed directly into the metal end-piece. To prevent the burning of the ebonite plug, its surface was covered with several thin sheets of mica. The pressure-recording apparatus consisted of a steel disc, F (4 cm. diameter), which fitted into a cylindrical hollow in one of the end-pieces and rested against a collar; graphite-asbestos washers were placed between them in order to ensure a pressure-tight joint. The disc was held in position by means of the hollow steel fitting, G, which was screwed to the main flange, B, by means of the bolts J. Any movement

of the disc was transmitted to the stainless steel mirror H, by means of the steel rod resting against it. The mirror, which was pivoted on sapphire bearings, was supported in a small steel cup; an aluminium cup, though preferable from the point of view of inertia, was not able to withstand the sudden shock without denting. Many trial experiments were made in order to discover the most suitable means of pressing the rod, firmly but lightly, against the mirror, so that the latter would respond smoothly and rapidly to the small displacements of the steel disc and yet return to its original zero position when the pressure returned to atmospheric. Springs of various strengths and shapes were tried, but it was found that the mirror could be kept in position most suitably by means of a stretched rubber band. The movements of the mirror were magnified, about 500-fold, by projecting on to it a narrow beam of light from an electric arc, the reflected beam being focussed on to sensitised paper fastened round a cylindrical drum rotated at a known rate by means of a motor. The velocity of the drum was adjusted to about 5 m.p.s., the speed being determined to within 1% by timing successive rings of an electric bell actuated by an endless gear on the drum. A second spark in series with the first, focussed on to the sensitised paper, recorded the moment of ignition of the mixture.

Since different explosive mixtures produced very different pressures, it was convenient to use three discs of different strengths: these gave similar maximum deflections, of about 4 cm. of the spot of light, at pressures of 10, 20, and 100 atmospheres respectively.

Whilst the main object of the research was to determine the rates of rise of pressure, it was possible, at least with some of the more dilute mixtures, also to measure the maximum pressures produced; for this purpose each steel disc had to be previously calibrated. This was accomplished by attaching a standard pressure gauge to the inlet of the bomb, filling the latter with compressed air, and measuring the deflection of the spot of light with different air pressures. The calibration curves were straight lines.

In carrying out an experiment, the bomb was evacuated to a pressure of 0.1 cm., or less, of mercury by means of a "Hyvac" oil pump and then filled with the gaseous mixture, dried by passage over soda-lime and calcium chloride. After adjustment of the pressure to atmospheric, the valve was closed, and the mixture ignited by means of a spark from an induction coil capable of giving a $1\frac{1}{2}$ " spark in air. After an experiment, the bomb was re-evacuated and kept under vacuum for about an hour, or for longer if the exploded mixture had contained much hydrogen. This procedure enabled concordant results to be obtained.

The mixtures were made from gases obtained from cylinders

(except in the case of carbon monoxide, which was prepared from sodium formate) and were stored over mercury or water according to the solubility of the constituents. They contained small amounts of nitrogen (usually 1–2%) as impurity. In the analysis, this amount is included with the oxygen.

When the mixture contained either a small or a large percentage of combustible gas, the curves traced by the spot of light were smooth and easy to measure. Fig. 2a is a reproduction of the record obtained when the mixture $2\text{CO} + \text{O}_2 + 0.8\% \text{H}_2$ was used, and is typical for dilute mixtures such as $2\text{H}_2 + 18\text{O}_2$, $\text{CH}_4 + 10\text{O}_2$, $\text{C}_2\text{H}_4 + 20\text{O}_2$, etc. On increase of the percentage of combustible gas, vibrations appeared at the peak of the curve, resulting in records similar to that shown in Fig. 2b ($2\text{H}_2 + 10\text{O}_2$). When

FIG. 2.

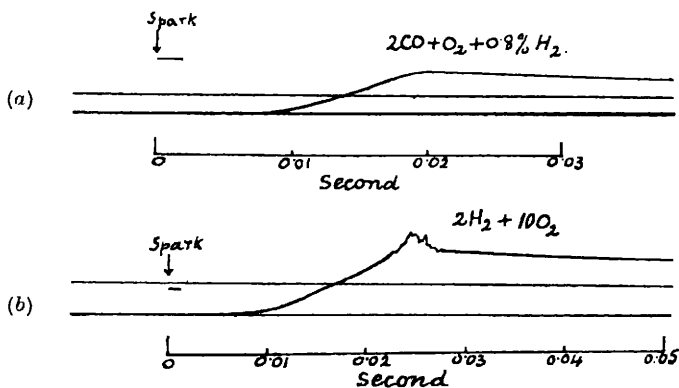

mixtures were used in which the amount of combustible gas approached that required for complete combustion, then, except in the case of carbon monoxide–oxygen mixtures, the rate of rise of pressure became exceedingly rapid and could only be measured very approximately; in many of these records, because of the violent vibrations of the recording apparatus, it was not possible to obtain any measure of the maximum pressure developed. Attempts were made to eliminate these vibrations by the insertion in the bomb of metal shields of various sizes at several different distances from the diaphragm; the resulting improvements were so small and so uncertain that the shields were finally discarded, and the results given were all obtained under similar experimental conditions.

It is very improbable in a cylinder of the above dimensions that detonation was set up, except possibly in the case of some of the most violent mixtures, *e.g.*, $\text{C}_2\text{H}_4 + 3\text{O}_2$. In such experiments

no record was obtained, probably because the spot of light moved too rapidly across the drum.

Results.—In the following tables are given the times (t_1) from the spark to the point of maximum pressure, and (t_2) from the first signs of pressure rise to the point of maximum pressure. In the case of some of the less violent mixtures, the maximum pressures produced are also given as $P_{\max.}$ (in terms of P_i , the initial pressure) but these can only be regarded as approximate. Since they would probably be different in another apparatus of different dimensions, no correction has been made for cooling losses, which would correspond to about $\frac{1}{2}$ atmosphere.

TABLE I.

Hydrogen-Oxygen Mixtures.

H ₂ , %	Mean time (secs.) to max. press.,		$\frac{P_{\max.}}{P_i}$
	t_1 .	t_2 .	
10.3	0.1637	0.1254	4.0
15.7	0.0247	0.0188	5.4
23.9	0.0070	0.0050	6.8
34.8	0.0032	0.0022	8.6
50.7	0.0033	0.0019	11 app.
82.4	0.0033	0.0020	8.2
89.6	0.0099	0.0072	6.0

TABLE II.

Ethylene-Oxygen Mixtures.

C ₂ H ₄ , %	Mean time (secs.) to max. press.,		$\frac{P_{\max.}}{P_i}$
	t_1 .	t_2 .	
3.9	—	0.0741	6.4
4.6	0.0533	0.0446	7.0
5.8	0.0196	0.0162	8.4
6.4	0.0147	0.0125	8.8
6.8	—	0.0106	9.2
8.0	0.0063	0.0052	9.6
10.0	0.0054	0.0037	—
10.6	0.0040	0.0030	10 app.

With hydrogen-oxygen mixtures no measurements were possible in the range 50–80% of hydrogen, but the time from the first sign of pressure rise to the maximum pressure in any such mixture cannot be greater than 0.002 sec.

TABLE III.

Methane-Oxygen Mixtures.

CH ₄ , %	Mean time (secs.) to max. press.,		$\frac{P_{\max.}}{P_i}$
	t_1 .	t_2 .	
6.7	0.1700	0.1448	5.4
7.5	0.1137	0.0934	7.6
8.9	0.0378	0.0318	7.6
10.7	0.0173	0.0149	8.2
11.0	0.0173	0.0141	12 app.
15.5	0.0051	0.0032	13 app.
21.1	0.0024	0.0017	13 app.
41.7	0.0023	0.0017	—
49.1	0.0124	0.0080	12 app.
49.5	0.0174	0.0108	10.0
52.1	—	0.0141	12 app.

TABLE IV.

Carbon Monoxide-Oxygen Mixtures.

CO, %	Mean time (secs.) to max. press.,		$\frac{P_{\max.}}{P_i}$
	t_1 .	t_2 .	
9.9	0.151	0.107	6.0
31.3	0.076	0.060	7.0
33.8	0.084	0.066	—
37.1	0.057	0.045	7.6
43.8	0.046	0.035	8.0
61.0	—	0.025	8.2
65.6	—	0.025	—
67.0	0.035	0.025	8.2
67.3	0.035	0.026	8.2
70.8	—	0.027	8.4
72.5	0.036	0.027	8.0
82.5	0.052	0.041	7.6
86.8	0.071	0.054	6.6
89.4	0.083	0.064	6.4
91.6	0.18	0.127	5.0

In the case of the ethylene-oxygen mixtures, satisfactory results were obtained when the amount of ethylene was between 4% and 11%. With stronger mixtures, the combustion was too violent to allow of measurement.

In the methane-oxygen series, measurements were not possible over the range 22–40% of methane.

FIG. 3.
Rates of rise of pressure of (i) CO-O₂ mixtures, (ii) H₂-O₂ mixtures,
(iii) CH₄-O₂ mixtures.

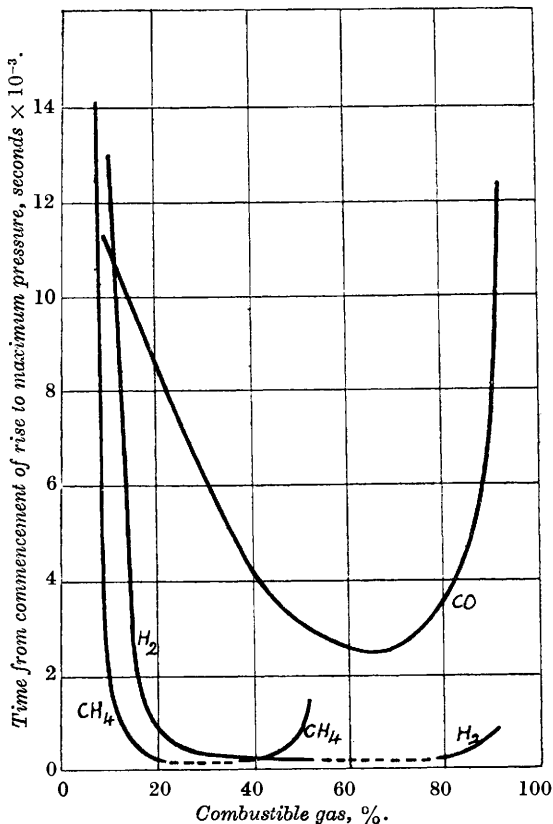

The values for the rate of rise of pressure of different mixtures of carbon monoxide and oxygen are dependent upon the amount of moisture present (Fenning, *loc. cit.*). In the experiments quoted above, the mixtures were, therefore, made up and allowed to stand for 18–20 hours over water at the laboratory temperature, *i.e.*, 15–17°. This small temperature variation, resulting in slightly different moisture contents of the mixtures, may account for the

fact that the agreement between individual time measurements was not quite so good as in the case of the mixtures already discussed. Hence the results in Table IV are only given to 0.001 sec. The results given in Tables I, III, and IV are plotted in Fig. 3. In the case of ethylene, the range of mixtures examined was too limited to be represented graphically.

It has been shown by Fenning and by Bone (*loc. cit.*) that with carbon monoxide-air mixtures the addition of hydrogen greatly reduces the time from the first signs of pressure rise to the maximum pressure. We have been able to show that a similar effect is produced when hydrogen is added to the mixture $2\text{CO} + \text{O}_2$, and further, that certain hydrocarbons produce a like result. In general, sufficient oxygen was present for complete combustion of the

TABLE V.

Carbon Monoxide-Hydrogen-Oxygen Mixtures.

Mixture, %.		Mean time (secs.) to max. press.,		$\frac{P_{\max.}}{P_1}$
CO.	H ₂ .	t ₁ .	t ₂ .	
66.0	0.0	0.035	0.0255	8.2
63.8	0.8	0.0195	0.0136	8.8
57.0	1.6	0.0165	0.0101	—
64.3	2.3	—	0.0078	—
62.7	2.8	0.0102	0.0073	9.0
62.2	3.7	0.0083	0.0063	8.8
60.8	4.3	0.0078	0.0057	9.2
59.1	6.7	0.0062	0.0048	9.2
54.7	9.3	0.0053	0.0044	—

TABLE VI.

Carbon Monoxide-Methane-Oxygen Mixtures.

Mixture, %.		Mean time (secs.) to max. press.,		$\frac{P_{\max.}}{P_1}$
CO.	CH ₄ .	t ₁ .	t ₂ .	
66.0	0.0	0.035	0.0255	8.2
65.8	0.3	0.0164	0.0113	8.6
66.5	0.8	0.0137	0.0094	8.6
63.8	1.5	0.0097	0.0071	9.0
57.0	3.8	0.0064	0.0050	—
47.6	9.0	0.0037	0.0027	—

TABLE VII.

Carbon Monoxide-Pentane-Oxygen Mixtures.

Mixture, %.		Mean time (secs.) to max. press.,		$\frac{P_{\max.}}{P_1}$
CO.	C ₅ H ₁₂ .	t ₁ .	t ₂ .	
66.0	0.0	0.035	0.0255	8.2
65.70	0.10	0.0224	0.0163	8.6
65.55	0.25	0.0161	0.0116	9.0
65.50	0.30	0.0156	0.0115	9.0
64.00	0.45	0.0123	0.0090	9.6
63.40	0.50	0.0116	0.0085	9.4
62.50	0.65	0.0097	0.0074	9.6
62.30	0.70	0.0100	0.0072	10 app.
61.40	0.90	0.0091	0.0066	—
60.50	1.00	0.0090	0.0060	—
59.75	1.15	0.0090	0.0059	—
58.80	1.30	0.0078	0.0054	—
57.80	1.50	0.0073	0.0050	—

TABLE VIII.

Carbon Monoxide-Acetylene-Oxygen Mixtures.

Mixture, %.		Mean time (secs.) to max. press.,		$\frac{P_{\max.}}{P_1}$
CO.	C ₂ H ₂ .	t ₁ .	t ₂ .	
66.0	0.00	0.035	0.0255	8.2
63.50	0.30	0.0242	0.0198	8.4
70.50	0.30	0.0285	0.0221	8.6
70.30	0.60	0.0205	0.0161	8.8
62.65	0.65	0.0181	0.0138	8.6
68.15	0.95	0.0167	0.0129	9.0
70.10	1.00	0.0151	0.0111	9.0
61.90	1.00	0.0138	0.0115	9.0
67.85	1.45	0.0120	0.0090	9.4
60.50	1.50	0.0125	0.0093	9.0
66.70	1.95	0.0090	0.0077	9.6
65.65	2.40	0.009	0.007	—

TABLE IX.

Carbon Monoxide-Ethylene-Oxygen Mixtures.

Mixture, %.		Mean time (secs.) to max. press.,		$\frac{P_{\max.}}{P_i}$
CO.	C ₂ H ₄ .	t_1 .	t_2 .	
66.0	0.0	0.035	0.0255	8.2
64.25	0.55	0.0157	0.0119	8.6
63.05	1.05	0.0120	0.0088	9.0
61.75	1.55	0.0100	0.0078	9.8
60.60	2.00	0.0084	0.0066	11 app.
59.40	2.50	0.0077	0.0058	9.6
56.20	3.20	0.0070	0.0055	9.8
57.90	3.15	0.0065	0.0048	—
52.50	6.50	0.0046	0.0034	—

FIG. 4.

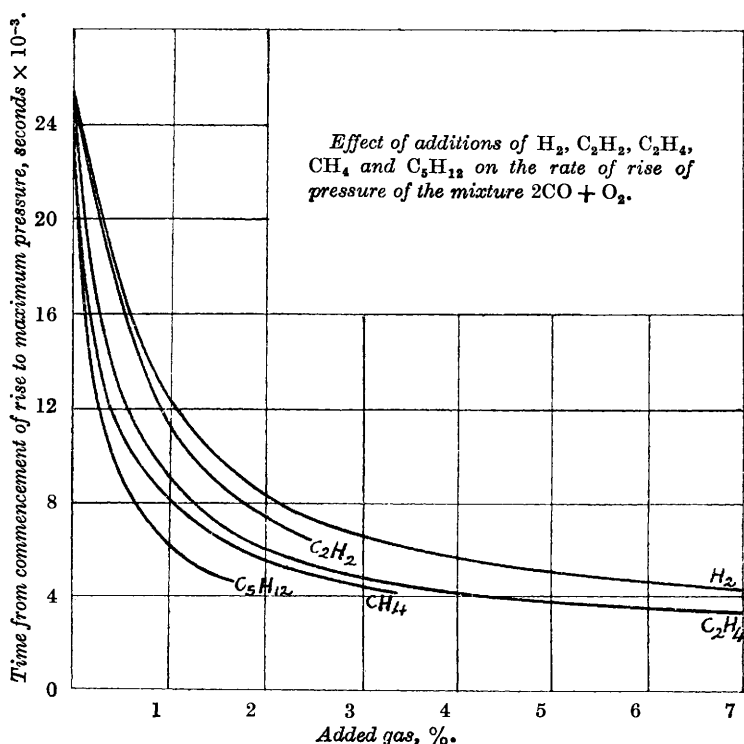

mixtures. The measurements obtained with such mixtures, dried by passage through tubes packed loosely with calcium chloride, are given in Tables V—IX. In each case the mixtures contained the quantities of carbon monoxide and added gas recorded, together with oxygen to make up 100%.

In some of the mixtures tabulated above it will be found that the amount of oxygen was, unintentionally, not quite enough to burn all the gases to completion, but this does not seem to be of prime importance. For instance, in Table VIII, when 1% of acetylene is present in two very different carbon monoxide-oxygen mixtures the times to reach maximum pressure and the maximum pressure produced are almost identical. The controlling factor, therefore, seems to be the amount of hydrogen, methane, etc., present in the mixture. In Fig. 4 these results are shown graphically.

Discussion of Results.—The results given for single combustible gas-oxygen mixtures show that the rates of rise of pressure for those mixtures containing excess of oxygen or of combustible gas are slower than mixtures whose compositions approximate more nearly to the theoretical mixture. These latter are all, with the exception of carbon monoxide-oxygen mixtures, so violent that measurements become impossible and one cannot say, in any one series, which mixture would give the most rapid rate of rise of pressure. The explosion wave in methane-oxygen mixtures travels most rapidly in the mixture containing 50% of methane, in which the reaction possibly corresponds to $\text{CH}_4 + \text{O}_2 \longrightarrow \text{CO} + \text{H}_2 + \text{H}_2\text{O}$, and not in the 33% mixture corresponding to $\text{CH}_4 + 2\text{O}_2 \longrightarrow \text{CO}_2 + 2\text{H}_2\text{O}$. We may assume that, in the latter case, the second molecule of oxygen is, in the explosion wave, acting as a diluent, just as Dixon (*Phil. Trans.*, 1893, **184**, A, 123) assumed for the reaction $\text{C}_2\text{N}_2 + 2\text{O}_2 \longrightarrow 2\text{CO}_2 + \text{N}_2$, in which the explosion rate is less than in that represented by the reaction $\text{C}_2\text{N}_2 + \text{O}_2 \longrightarrow 2\text{CO} + \text{N}_2$. In the above experiments in the bomb, however, the mixture developing pressure most rapidly evidently lies between $\text{CH}_4 + 1.3\text{O}_2$ and $\text{CH}_4 + 4\text{O}_2$, and is quite possibly the mixture $\text{CH}_4 + 2\text{O}_2$. The second molecule of oxygen is, in this case, not merely acting as a diluent but is taking some part in the reaction. This might possibly explain why the mixture $\text{CH}_4 + \text{O}_2 + \text{N}_2$ ($\text{O}_2 = 33\%$) would not ignite in the bomb; it was necessary that the content of oxygen should be not less than 37% before inflammation would take place.

In the case of moist carbon monoxide-oxygen mixtures, the curve seems to indicate that the mixture which develops pressure most rapidly is not very remote from the theoretical mixture containing about 66% of carbon monoxide. The rate of rise of pressure is affected to different degrees when other combustible gases as well as carbon monoxide are present, the effect increasing in the order hydrogen, acetylene, ethylene, methane, pentane. The two unsaturated hydrocarbons have apparently less effect, for

equal amounts, than methane and pentane, and the influence of the hydrocarbons is in the order of their hydrogen contents.

The mixtures which have a slow rate of rise of pressure are also those which detonate with difficulty when ignited in a long tube. For methane-oxygen, Payman and Walls (J., 1923, **123**, 420) found that the limit of detonation is 11.1% of methane: in this laboratory it has been found, using different methods of ignition, that the lower limit of detonation probably lies between 10.0% and 10.5% of methane. From the curves given above, the time between the first signs of pressure rise and maximum pressure, when the mixture is ignited in the bomb, is approximately 0.04 sec. In Table X are given the compositions of a number of different mixtures requiring this same time to reach maximum pressure, and also the limits of detonation as determined by different observers using slightly different methods.

TABLE X.

Detonation Limits of Combustible Gas-Oxygen Mixtures.

Amount of combustible gas in the mixture reaching max. press. in 0.04 sec.	Detonation limits.	
	Published.	Unpublished; obtained in these laboratories.
55% CH ₄ (By extrap ⁿ)	53.3% CH ₄ (Payman and Walls)	56% CH ₄
9% CH ₄	11.1% CH ₄ (Payman and Walls)	10% CH ₄
4.8% C ₂ H ₄	—	5% C ₂ H ₄
15% H ₂	18% H ₂ (In air; Wendlandt)	—
83% CO	82% CO (Bone)	83% CO
40% CO	{ 38% CO (Wendlandt) } { 40% CO (Bone) }	38% CO

The agreement between the detonation limits and the rate of rise of pressure seems more than fortuitous, and it is possible that the detonation limits of other mixtures might be predicted by determining that mixture which, in this particular apparatus, would reach its maximum pressure in 0.04 sec.

The authors desire to express to Mr. Norman Calvert, M.Sc., their thanks for assistance in the many preliminary experiments which led to the successful working of the apparatus. They wish to acknowledge the receipt of a grant for apparatus from the Royal Society, and they are also indebted to the Imperial Chemical Industries Ltd. for assistance.