

**204.** *Primary Photochemical Processes. Part I.  
The Decomposition of Formaldehyde.*

By RONALD G. W. NORRISH and FREDERICK W. KIRKBRIDE.

OF recent years it has become possible to inquire with advantage into the nature of the primary photochemical change. As a result it is evident the majority of photochemical changes in gases and vapours are associated with two types of absorption spectrum of the photoactive substance. This spectrum consists either of a

series of bands with a complete absence of fine structure, or of a region of altogether continuous absorption without any evidence of bands. According to modern spectroscopic theory, this absence of the fine rotational lines, which usually characterise the absorption spectra of molecules, is associated with the onset of photochemical decomposition. When a series of continuous bands without rotational structure are shown, the condition has been termed by Henri "predissociation," and it has been proved that in this case, as the result of the absorption of the light quantum, the molecule undergoes disruption within an interval less than its rotation period. For example, in the case of ammonia we have  $\text{NH}_3 + h\nu = \text{NH}_2 + \text{H}$ , the reaction rate being independent of collision frequency down to low pressures (Bonhoeffer and Farkas, *Z. physikal. Chem.*, 1928, **134**, 337).

A similar observation in the case of continuous absorption has been made by Lewis for hydrogen iodide (*J. Physical Chem.*, 1928, **32**, 270), and here also it is clear that the primary effect is the dissociation of the molecule within a very short interval after the act of absorption.

It is remarkable that very few reactions in gases and vapours are known which can be unequivocally stated to be associated with a part of the spectrum showing fine structure. In the case of nitrogen peroxide, predissociation begins at 3800 Å.U., and Norrish (*J.*, 1929, 1158, 1604, 1611) found that this point in the spectrum is associated with a photochemical threshold, in the sense that with longer wave-lengths the quantum efficiency rapidly falls away from the limiting value of 2, found at shorter wave-lengths, reaching zero at about 4100 Å.U. Here we undoubtedly have photochemical reactivity in a region showing rotational fine structure, but this may be explained if we assume an overlap with another band system and a gradual fading out of the predissociation between 3800 and 4100 Å.U. As Henri has shown ("Leipziger Vorträge," 1931, p. 131), such an assumption is in good agreement with the recently determined heat of dissociation of oxygen.

On the other hand, the decomposition of nitrosyl chloride is more difficult to explain, since here, according to Kistiakowski (*J. Amer. Chem. Soc.*, 1930, **52**, 102), the quantum efficiency continues uniformly at 2 as one passes from the region of predissociation to that of fine structure. This fact makes it impossible to account for the results by a gradual fading-out of predissociation as with nitrogen peroxide, and it must be assumed that the excitation process can lead to photochemical reactivity, *e.g.*,

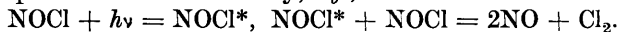

Apart from the data on nitrogen peroxide and nitrosyl chloride,

the only work which appears to be of sufficient precision to bear conclusively on the subject is de Hemptinne's study of the decomposition of benzaldehyde (*J. Phys. Radium*, 1928, **9**, 357); here it seems that photochemical reactivity is definitely confined to the predissociation region. The other work of Henri and his collaborators must be considered inconclusive on account of the meagre data supplied and the doubtful character of some of the filters employed.

The existing evidence can thus hardly be said to establish definitely any general relation between photochemical and predissociation thresholds, and in view of the importance of the problem, there is need for the careful study of further simple photochemical changes for the purpose of comparing the reactivity in the fine-structure and predissociation regions. We selected formaldehyde for the present study, first, because its predissociation limit is accurately known, secondly, because of the simplicity of the photochemical change  $\text{CH}_2\text{O} = \text{H}_2 + \text{CO}$ , and thirdly, because its decomposition is typical of a number of similar changes with other aldehydes,  $\text{R}\cdot\text{CHO} = \text{RH} + \text{CO}$ , which at least qualitatively seem to be associated with predissociation. On the other hand, formaldehyde is not an easy substance to work with, partly on account of its comparatively weak absorption, and partly because its tendency to polymerise at room temperature necessitated working at 100—110°. These difficulties were, however, overcome, and in the subsequent determinations of quantum efficiency the results were reproducible to  $\pm 15\%$ .

The absorption spectrum of formaldehyde from 3700 to 2500 Å.U. has been examined in detail by Henri and Schou (*Z. Physik*, 1928, **49**, 774) and by Herzberg (*Trans. Faraday Soc.*, 1931, **27**, 378). The spectrum shows rotational fine structure down to 2750 Å.U., but between 2750 and 2670 Å.U. there is a transition to a predissociation region, which continues to 2500 Å.U., where absorption ceases. The predissociation limit moves 70 Å.U. towards the visible region if the temperature is raised to 220°.

Formaldehyde was first investigated photochemically by Berthelot and Gaudechon (*Compt. rend.*, 1910, **151**, 478), who found that, in the form of trioxymethylene, it is decomposed by ultra-violet light, giving mainly hydrogen and carbon monoxide, together with small quantities of carbon dioxide and methane. Later, Bredig and Goldberger (*Z. physikal. Chem.*, 1924, **110**, 532) studied the reaction in the vapour phase. At 80° this proceeded almost quantitatively according to the equation  $\text{CH}_2\text{O} = \text{H}_2 + \text{CO}$ , but at 195° considerable quantities of carbon dioxide and methane were formed. The reaction proceeded in a unimolecular manner at low pressures

of formaldehyde, but became of zero order as the pressure and thickness of the absorbing layer were increased. These authors did not attempt to measure the quantum efficiency of the reaction, or to characterise the wave-length of the active radiation.

Bates and Spence (*J. Amer. Chem. Soc.*, 1931, **53**, 1694) state that the rate of polymerisation of formaldehyde (at 0°) is increased by ultra-violet light; but since the curve which they reproduce shows no distinct break at the point where illumination was begun, and in the present investigation no effect of this kind was noticed, the effect if real must be slight.

In our own preliminary experiments, using a colour filter of "Vita" glass which cut off light of wave-lengths less than 280  $\mu\mu$ , we observed a six-fold decrease of reaction velocity, and, allowing for possible imperfections of the filter, this was taken as confirming the dependence of photochemical decomposition on predissociation, as stated by us in a recent paper on the photochemical properties of the carbonyl group (*Trans. Faraday Soc.*, 1931, **27**, 404). It was, however, subsequently found impossible to account for the residual decomposition by the imperfection of the colour filter, and it became apparent that photochemical action was also to be attributed to the longer wave-lengths of the mercury lamp at 310  $\mu\mu$ , and that these were transmitted by the glass filter less than we had originally supposed.

It was then obvious that the only adequate test was to measure the quantum efficiency of the decomposition on both sides of the predissociation limit. The results obtained were not in accord with our preliminary conclusion, for the quantum efficiency is of the order of unity for each of the spectral regions 254—265, 303—313, and 334—365  $\mu\mu$ , while the predissociation limit at 100° cannot lie higher than 280  $\mu\mu$ , according to the measurements of Henri and Schou (*loc. cit.*).

#### EXPERIMENTAL.

*Preparation of Formaldehyde.*—Monomeric formaldehyde was prepared by distilling paraformaldehyde according to the method of Trautz and Ufer (*J. pr. Chem.*, 1926, **113**, 105). The liquid-air traps employed for condensation and redistillation were of the ordinary type having one internal seal. All the connecting tubing of the preparation train was wound with nichrome wire and asbestos cord, and a current passing through the wire maintained the temperature at 90°.

The distillations were thus effected without serious polymerisation, and the final product was such that its vapour, when confined in a bulb at 110° and pressures up to 170 mm., initially showed a pressure fall of only 0.05—0.1 mm. per minute, which decreased to 1—2 mm.

per hour. This pressure fall may be ascribed to polymerisation occurring near the taps, which, for want of a suitable tap-grease, were not directly heated.

*Preliminary Investigation.*—In the apparatus for the preliminary study of the decomposition, a double-walled cylindrical silica reaction vessel of 130 c.c. capacity was used (Fig. 1). The space between the double walls was filled with distilled water, and was electrically heated in such a way that the water was kept gently boiling; the temperature of the vessel was thus maintained constant at 100°. The vessel was connected, *via* a ground joint, to a mercury

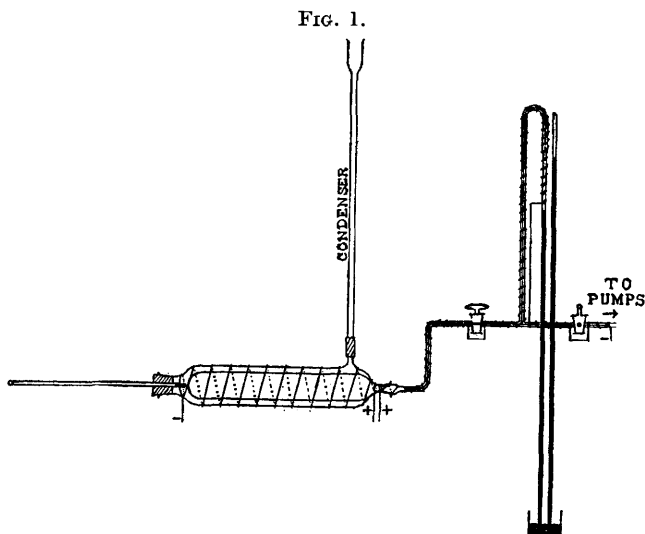

manometer, and, through taps, to the reservoir of formaldehyde and to the Hyvac and Töpler pumps. All the connecting tubing was heated as described above, and the ground joint was lubricated with a high-temperature grease made by dissolving excess of crêpe rubber in vaseline. In order to get a great intensity of illumination, a mercury-arc lamp was mounted parallel to the reaction vessel and at 10 cm. from it.

In the full light of the mercury lamp a rapid decomposition set in, the pressure tending towards a value double that of the original formaldehyde vapour. When the filter of "Vita" glass was inserted the rate of decomposition dropped to one-sixth, and, as stated above, this residual change must be due to wave-lengths greater than 280  $\mu\mu$ , since absorption photographs taken with the mercury and iron arcs indicated that the "Vita" glass was completely opaque below this wave-length.

In a series of runs, with and without the filter, the products of decomposition were pumped off by the Töpler pump and analysed in a gas burette designed to deal with small quantities of gas up to 6 c.c. The analyses confirmed the results of Bredig and Goldberger and showed that the decomposition to the extent of 95% can be represented by the simple equation  $\text{CH}_2\text{O} = \text{H}_2 + \text{CO}$ , and that it is the same for filtered light of wave-length longer than  $280\ \mu$  as it is for the shorter wave-length light of the predissociation region. The results of the analyses are tabulated below. The pressure fall observed in Expts. I and II occurred because the slow polymerisation was more rapid than the decomposition due to the long-wave ultra-violet light.

	Expt. I. Filter of 4.5 mm. " Vita " glass.	Expt. II. Filter of 7 mm. " Vita " glass.	Expt. III. No filter.	Expt. IV. Vessel kept in the dark.
Duration of exposure (mins.) ...	180	180	60	123
Initial pressure (mm.) .....	111.5	102.8	103.4	112.9
Final pressure (mm.) .....	103.3	90.5	113.3	102.9
Gas collected (c.c. at N.T.P.) ...	2.71	1.41	4.89	<0.06
Carbon monoxide, % .....	51.0	50.4	51.2	—
Hydrogen, % .....	45.5	47.5	48.5	—
Methane, % .....	2.4	—	0.4	—
Carbon dioxide, % .....	0.8	Nil	Nil	—

#### *Measurement of the Quantum Efficiency of the Reaction.*

The quantum efficiency was measured for the three spectral regions, 254—280, 303—313, and 334—365  $\mu$ .

On account of the slow polymerisation it was necessary to measure the amount of decomposition by pumping off the products and estimating the carbon monoxide formed. For this purpose, owing to the low intensity of the monochromatic beams, and the weak absorption of the formaldehyde, exposures of some 17 hours were necessary. The light absorption was calculated from the incident flux and the absorption coefficients of the formaldehyde for the different wave-lengths employed, the coefficients being determined in separate experiments.

The reaction vessel (Fig. 2) consisted of a quartz bulb of 220 c.c. capacity, supported in a cylindrical electric furnace closed at one end by a lens, and at the other by a quartz window. The furnace was maintained always at  $110^\circ$ . The reaction bulb was connected to the pumps, manometer, and supply tube through a ground-glass joint lubricated with a high-temperature tap-grease, and (in the later runs) sealed with "Picein." As before, all connecting tubing was electrically heated.

The manometer was U-shaped; the right-hand limb *A* was

evacuated by the Hyvac pump, and by means of the levelling-tube attached to the tube *B*, the mercury surface in the left-hand limb was kept always at the same point of the scale.

On account of the presence of the furnace, a thermopile could not be used to measure the light flux, hence a gas-filled sodium photoelectric cell, with a quartz window, was employed. The cell was sufficiently sensitive to be used in conjunction with a sensitive moving-coil galvanometer, which was rendered dead-beat by a shunt of 3,500 ohms. The cell was sensitive to light of all wave-lengths from the far ultra-violet to the blue; green and yellow light also affected it slightly.

The optical system was as shown in Fig. 2. The diaphragm *D*<sub>1</sub>, with an aperture of 2 cm., was as close to the lamp as possible, and about 5 cm. in front of *D*<sub>1</sub> was another diaphragm *D*<sub>2</sub>, also of

FIG. 2.

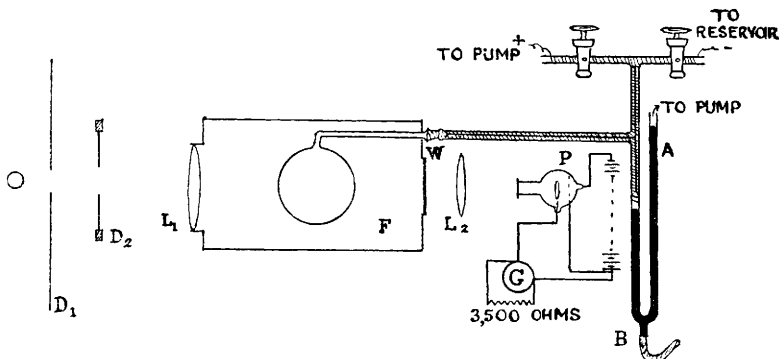

about 2 cm. aperture. After *D*<sub>2</sub> the light fell on a large quartz lens *L*<sub>1</sub> (of 10 cm. focal length and at 18 cm. from *D*<sub>1</sub>), entered the furnace, and passed through the reaction vessel, coming to a focus near the far end of *F*. After traversing the quartz window *W*, it was made to converge again by the quartz lens *L*<sub>2</sub> (6 cm. focal length), so that it fell on the photoelectric cell *P*.

*Calibration of Photoelectric Cell.*—The cell was first calibrated directly for light of wave-lengths 436 and 365  $\mu\mu$  by comparison with a thermopile circuit, of which the erg-sensitivity had been accurately determined by means of a standard carbon-filament lamp supplied by the National Physical Laboratory. The erg-sensitivity at 313 and 256  $\mu\mu$  was then obtained relatively to that at 436 and 365  $\mu\mu$  by comparison of the four wave-lengths, a monochromator and thermopile being used. The following results were obtained :

## Potential on cell—112 volts.

1 Cm. of galvanometer deflexion corresponds to

Wave-length ( $\mu\mu$ ).	Erg-sensitivity (ergs/sec.).	Quantum sensitivity (quanta/sec. $\times 10^{-14}$ ).
436	1230	2.74
365	591	1.10
313	477	0.76
254	1680	2.17

In practice it was convenient to use the cell at voltages lower than 112, and conversion factors for these lower voltages were separately determined.

*Colour Filters and Light Source.*—For isolating the various wave-lengths used, the following colour filters were employed :

436  $\mu\mu$ . A 3-cm. layer of 1% aqueous solution of tetramminocupric sulphate (Vanino, "Präparative Chemie," 1921, I, p. 500), combined with a 0.5-cm. layer of 4% aqueous quinine hydrochloride solution.

365  $\mu\mu$ . A Wratten "mercury monochromat filter No. 18a."

313  $\mu\mu$ . A 2-cm. layer of an aqueous solution containing 0.135 g./litre of potassium chromate and 0.014 g./litre of *p*-nitrosodimethylaniline, approximately as recommended by Winther (*Z. Elektrochem.*, 1913, **19**, 390), supplemented by a 2-mm. plate of "Vita" glass. A photograph of the mercury-arc spectrum through this combination showed that no trace of any line below 297  $\mu\mu$  was transmitted. A quantity of visible light was transmitted whose residual effect on the photoelectric cell was determined by cutting out the ultra-violet light with a 0.5-cm. layer of 4% quinine hydrochloride solution; the transmission of this quinine filter for visible light was separately determined.

254  $\mu\mu$ . A 5-cm. layer of chlorine at atmospheric pressure. This filter transmitted light of wave-lengths 254 and 265  $\mu\mu$ , but extinguished all wave-lengths between 280  $\mu\mu$  and the visible region. The intensity of the visible radiation transmitted was high, and, as for the 313  $\mu\mu$  filter, it had to be separately determined and allowed for, by introducing a glass plate of known transmission and measuring the residual deflexion.

The light source was a mercury-vapour lamp, straight pattern, run off a storage battery of 220 volts, and consuming a current of 2.5 amps. with a terminal voltage on the lamp of 150.

*Determination of the Absorption Coefficient of Formaldehyde.*—The above filters being used, the light absorption of the formaldehyde at large pressures up to 500 mm. in the reaction vessel was directly measured. From the figures so obtained, the absorption at the lower pressures used in the quantum efficiency measurements could be calculated.



The following values of  $1/p \cdot \log_{10} I_0/I$  were found,  $p$  being the pressure in mm. at  $110^\circ$ , and  $I_0$  and  $I$  representing the incident and the transmitted light respectively.

Wave-length, $\mu\mu$ .	$1/p \cdot \log_{10} I_0/I$ .	Approximate molecular extinction coefficient (decadic logarithms).
254—265	$(3.0 \pm 0.2) \times 10^{-4}$	0.89
303—313	$(8.2 \pm 0.6) \times 10^{-4}$	2.4
365	$(2.5 \pm 0.5) \times 10^{-5}$	0.07

*Correction for Absorption and Reflexion Losses.*—In measuring the light-flux, correction must be made for light losses at the back face of the vessel and the successive reflecting surfaces of the optical system, and for the absorption by the quartz, which for the shorter wave-lengths was quite high. These losses were therefore determined by direct transmission tests on the vessel, window, and lens, at each of the three wave-lengths.

*Course of an Experiment.*—When the furnace and mercury lamp had come to a steady state, the intensity of the light beam was measured as described above. Formaldehyde was then admitted to the reaction vessel to a pressure of about 170 mm., and irradiated for about 17 hours. A final reading of the pressure was made and the gases were then pumped out by the Töpler pump through liquid air, and collected. The carbon monoxide was estimated as before, and taken as a measure of the number of molecules of formaldehyde decomposed. Two control experiments in which formaldehyde at 170 mm. pressure was kept in the reaction vessel in the dark at  $110^\circ$  for 20 hours yielded no trace of carbon monoxide.

The final pressure of formaldehyde was deduced from the observed final pressure by subtracting the pressure due to the decomposition products; it was usually about 20% less than the initial pressure. The mean of the initial and the final pressure was then used to calculate the mean light absorption, the absorption coefficients listed above being used, and the quantum efficiency was calculated from the sensitivity of the photoelectric cell at the wave-length employed. The final results were as set out below.

At  $\lambda = 254\text{—}265 \mu\mu$ .

Photoelectric cell at 40 volts.

Conversion factor from 112 volts = 1 : 1.69.

	I.	II.	III.	IV.
Incident light flux (in cm. defn.) ...	7.35	6.1	7.5	5.0
Initial press. of $\text{CH}_2\text{O}$ (mm.) .....	170	172	175	174
Final press. of $\text{CH}_2\text{O}$ (mm.) .....	114	115	120	155
$\therefore$ Mean absorption (in cm. defn.) ...	0.69	0.57	0.72	0.53
Do. corrected for light losses .....	1.43	1.19	1.51	1.11
Time of illumination (secs.) .....	61,200	59,400	60,600	27,000
$\therefore$ Quanta absorbed $\times 10^{-19}$ .....	3.20	2.61	3.36	1.10
CO measured (c.c.) .....	1.09	0.86	0.99	0.42
$\therefore$ Mols. decomp. $\times 10^{-19}$ .....	2.96	2.33	2.68	1.12
$\therefore \gamma$ .....	0.9	0.9	0.8	1.0

At  $\lambda = 303\text{--}313 \mu\mu$ .

Photoelectric cell at 95 volts.

Conversion factor from 112 volts = 1 : 1.11.

	I.	II.	III.
Incident light flux (in cm. defn.) ...	6.15	9.0	4.95
Initial press. of $\text{CH}_2\text{O}$ (mm.) .....	178	178	174
Final press. of $\text{CH}_2\text{O}$ (mm.) .....	124	139	152
$\therefore$ Mean absorption (in cm. defn.) ...	1.51	2.31	1.29
Do. corrected for light losses .....	2.52	3.85	2.15
Time of illumination (secs.) .....	61,320	61,200	64,500
$\therefore$ Quanta absorbed $\times 10^{-19}$ .....	1.30	1.99	1.17
CO collected (c.c.) .....	0.53	0.79	0.48
$\therefore$ Mols. decomp. $\times 10^{-19}$ .....	1.43	2.14	1.29
$\therefore \gamma$ .....	1.1	1.1	1.1

At  $\lambda = 365 \mu\mu$ .\*

Photoelectric cell at 42 volts.

Conversion factor from 112 volts = 1 : 1.64.

	I.	II.	III.
Incident light flux (in cm. defn.) ...	46.3	41.8	40.9
Initial press. of $\text{CH}_2\text{O}$ (mm.) .....	178	181	176
Final press. of $\text{CH}_2\text{O}$ (mm.) .....	130	159.5	138
$\therefore$ Mean absorption (in cm. defn.) ...	0.40	0.40	0.36
Do. corrected for light losses .....	0.60	0.60	0.54
Time of illumination (secs.) .....	73,800	74,300	73,200
$\therefore$ Quanta absorbed $\times 10^{-18}$ .....	8.03	8.07	7.19
CO collected (c.c.) .....	0.26	0.17	0.15
$\therefore$ Mols. decomp. $\times 10^{-18}$ .....	7.0	4.6	4.1
$\therefore \gamma$ .....	0.9	0.6	0.6

\* At this wave-length the results must be regarded as correct only as regards order of magnitude, since both the light absorption and the amount of decomposition were very small.

The mean value for the quantum efficiency ( $\gamma$ ) is 0.9 at 254—265  $\mu\mu$ , and 1.1 at 303—313  $\mu\mu$ , so that within the experimental error it is unity, both in the predissociation region and at a considerable distance on the long-wave side of the predissociation limit (which is at about 280  $\mu\mu$ ). Even at 365  $\mu\mu$ , the quantum efficiency is of the same order, though here, however, the decomposition may have been chiefly due to the weak light of wave-length 334  $\mu\mu$ , which was transmitted appreciably by the Wratten filter. The results therefore show that there is probably no sharp photochemical threshold anywhere in the absorption region from 370 to 250  $\mu\mu$ , and certainly none to correspond with the predissociation limit.

#### Discussion of Results.

There were two questions to be answered with reference to the primary photochemical change in formaldehyde: (i) How far is the photochemical decomposition confined to the spectral region of predissociation? (ii) What is its nature?

(i) It is clear from our present results that the decomposition is by no means limited to the predissociation region, but that it con-

tinues unabated in the region of fine structure, with a nearly uniform quantum efficiency throughout the whole absorption system. Thus, while we may admit that the spectral data indicate a spontaneous decomposition independent of collision in the case of predissociation, we must admit also an equal probability of decomposition of excited molecules by collision in the region of fine structure. For this type of change we shall write

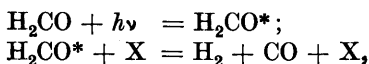

where X is any second molecule, the energy of excitation being redistributed by collision in such a way as to lead to molecular dissociation.

There seems evidence for a similar process in the case of chlorine, which has been shown to be photochemically active towards hydrogen in the spectral region of fine structure, outside its dissociation region (Allmand, *Trans. Faraday Soc.*, 1931, **27**, 425). For this we may similarly suggest

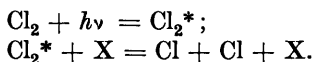

For the case of nitrosyl chloride referred to in the introduction we must also suppose

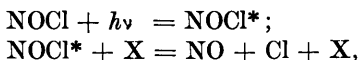

though here, in view of energy relationships, the second molecule X must also act as an acceptor for the chlorine atom, *e.g.*,  $\text{NOCl}^* + \text{NOCl} = 2\text{NO} + \text{Cl}_2$ .

In the present instance of formaldehyde, the reaction  $\text{CH}_2\text{O} = \text{H}_2 + \text{CO}$  is almost thermo-neutral, so if we regard this as the primary change there is no difficulty in imagining the collision of activated molecules as leading to reaction, and the original energy of excitation will appear in these products.

(ii) This, however, involves the second of the above questions, the nature of the change. Two primary processes have been proposed, that of Henri ("Leipziger Vorträge," 1931, p. 131), of Herzberg (*Trans. Faraday Soc.*, 1931, **27**, 378), and of Mecke (*Nature*, 1930, **125**, 526), involving the elimination of a hydrogen atom in the predissociation change:  $h\nu + \text{CH}_2\text{O} \longrightarrow \text{H} + \text{CHO}$ , and that of the present authors (*Trans. Faraday Soc.*, 1931, **27**, 404), involving primary splitting into hydrogen and carbon monoxide molecules without production of atoms:  $\text{CH}_2\text{O} + h\nu = \text{H}_2 + \text{CO}$ . The present results confirm the latter mechanism. In the first instance, if hydrogen atoms are liberated we might reasonably

expect a quantum efficiency greater than unity, since secondary processes, such as  $\text{H} + \text{CH}_2\text{O} = \text{H}_2 + \text{CHO}$ , would surely be possible. This is not found to be the case. In the second instance, the evidence for the production of atoms was based on the adequacy of the energy value of the quantum as compared with the thermal value of the C-H bond. This agreement disappears in view of the practically unabated reactivity at longer wave-lengths. For example, the energies of the quanta of wave-lengths 334—365 and 310  $\mu\mu$  are about 80,000 and 92,000 cal./g.-mol. respectively, while the value of the C-H bond is 93,600 cal./g.-mol. (Dickinson, Dillon, and Rasseti, *Physical Rev.*, 1929, **34**, 582).

If, however, the energy of binding of carbon to hydrogen in formaldehyde be considered less than the above, we might still suppose that the decomposition involving hydrogen atoms occurs when the energy of excitation is redistributed on collision.

Such evidence as exists is against this possibility, for when we consider the analogous decompositions in other aldehydes we find that apparently only one hydrocarbon, and no hydrogen, is produced from each aldehyde.

The following changes illustrate this :

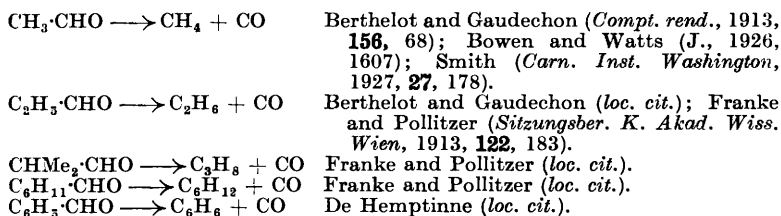

These reactions are completely analogous to that of formaldehyde, photodecomposition occurring in all cases in the region round 290  $\mu\mu$  in the absorption system corresponding to the carbonyl group, and being associated qualitatively with predissociation. If, however, they had involved hydrogen atoms or free radicals produced in a primary change analogous to that suggested by other workers for formaldehyde, hydrogen in all cases, and hydrocarbons (*e.g.*, ethane in the case of acetaldehyde, and diphenyl in that of benzaldehyde) would be expected in appreciable quantities. Yet these are not found, and all the above changes appear to occur practically exclusively as represented.

On the other hand, it is to be admitted that the analytical data for these reactions are not always as complete as could be desired, and it is hoped to test the point with greater certainty by re-examining certain of the above changes. For the above reasons we prefer the primary decomposition involving carbon monoxide and hydrogen

molecules—by spontaneous dissociation in the predissociation region, and by activation followed by collision in the region of fine structure :  $\text{CH}_2\text{O}^* + \text{X} = \text{H}_2 + \text{CO} + \text{X}$ .

*Summary.*

A study has been made of the photochemical decomposition of formaldehyde vapour. The following change takes place almost quantitatively :  $\text{H}_2\text{CO} = \text{H}_2 + \text{CO}$ .

The quantum efficiencies in the spectral regions 365—334, 313—303, and 265—254  $\mu\mu$  are found to be 0.7, 1.1, and 0.9, respectively, while the predissociation limit lies at 280  $\mu\mu$ . There is thus no evidence for a photochemical threshold associated with the predissociation limit. It is considered that the balance of evidence is against representation of the primary photochemical change as a splitting off of a hydrogen atom, and evidence is offered for the primary dissociation into hydrogen and carbon monoxide molecules :  $h\nu + \text{CH}_2\text{O} = \text{H}_2 + \text{CO}$ . This takes place spontaneously in the predissociation region, while in the region of fine structure it occurs as a result of a collision between an excited molecule and a second body, such a collision bringing about dissociation by a redistribution of the energy of excitation.

Our acknowledgments are due to the Royal Society and the Chemical Society for grants towards the cost of apparatus, to the Department of Scientific and Industrial Research and to Emmanuel College, Cambridge, for maintenance grants to one of us (F. W. K.), and to Dr. F. P. Bowden for assistance with his monochromator in calibrating the photoelectric cell.

DEPARTMENT OF PHYSICAL CHEMISTRY,  
CAMBRIDGE.

[Received, March 23rd, 1932.]

---