

37. *Primary Photochemical Processes. Part II. The Absorption Spectrum and Photochemical Decomposition of Diazomethane.*

By FREDERICK W. KIRKBRIDE and RONALD G. W. NORRISH.

CURTIUS (*Ber.*, 1908, **41**, 3168) has recorded that, in sunlight, an ethereal solution of diazomethane evolved gases which he presumed to be ethylene and nitrogen, and that the solution on evaporation yielded a viscous residue. No other observation upon the photochemistry of diazomethane was on record, although the subject offered many problems of interest, *e.g.*, the nature of the primary photochemical change, its relation to the type of absorption spectrum exhibited by the vapour, and whether, in view of the endothermic nature of the substance, the products of the primary change were able to initiate reaction chains leading to an explosive decomposition similar to that observed thermally.

In a qualitative and partly quantitative study of the absorption spectrum of diazomethane, correlated with the photochemical decomposition in the gas phase with reference to the nature and proportions of the products and to the quantum efficiency of the reaction,

we have found, using instruments of high dispersion, two regions of absorption, the first in the blue and violet, showing a structure suggesting predissociation, the second, very intense and continuous, in the ultra-violet beyond 2650 Å.U. A spectrophotometric measurement of the former region, when compared with the spectrum of azomethane, gives some confirmation of the ring structure for diazomethane (Hantzsch and Lifschitz, *Ber.*, 1912, **45**, 3022; Sidgwick, *J.*, 1929, 1108), and a comparison of the products of decomposition of the pure substances with those obtained in the presence of hydrogen or oxygen indicates the primary photochemical change as a severance of the two nitrogen atoms from the molecule. The subsequent history of the CH₂ radical, leading mainly to ethylene and propylene but also to other by-products, can be fairly satisfactorily traced.

The thermal decomposition of diazomethane was investigated by Steacie (*J. Physical Chem.*, 1931, **35**, 1493), who found a homogeneous bimolecular reaction at temperatures above 135°, with a heat of activation of about 36,000 cal./g.-mol., occurring according to the equation $2\text{CH}_2\text{N}_2 = \text{C}_2\text{H}_4 + 2\text{N}_2$. On the other hand, as might be expected from the strongly endothermic character of the substance, the decomposition readily became explosive, and there appeared to be an explosion limit of *ca.* 10 cm. at 217° and *ca.* 18 cm. at 187°. The explosions, however, were so uncontrollable, and so obviously dependent on the condition of the walls of the vessel, that no reliable data were obtained and the work was abandoned.

Photochemically we have found similar decomposition products, a large proportion of the diazomethane vapour reacting to give olefins and nitrogen, and the results appear to be the same with light of wave-length corresponding either to the first or to the second absorption region. In addition, however, there is a liquid substance, containing nitrogen, deposited on the walls of the reaction vessel, whose formation can be explained as a secondary "dark" process, in terms of reactions known to occur between olefins and diazomethane.

The determination of the quantum efficiency yielded values of 4–5 for light of wave-lengths 436 and 365 mμ. In no instance could an explosion be started photochemically; there is thus no evidence for a chain of any appreciable length, a fact which is somewhat surprising in view of the strongly exothermic character of the decomposition.

EXPERIMENTAL.

Preparation of Diazomethane.—CH₂N₂ was prepared (after Meerwein and Burnleit, *Ber.*, 1928, **61**, 1840) by the action of a solution of Na in ethylene glycol on nitrosomethylurethane; not more than 1.5 c.c. of the latter were used in each prepn., and the containing vessel was kept at 0° by immersion in ice-water. A current of dry N which was passed through the apparatus conveyed the evolved CH₂N₂, via a spiral immersed in ice and HCl aq., to a trap immersed in liquid air, where it was frozen out. The CH₂N₂ was freed from less volatile impurities by distillation in vac. from a trap cooled in solid CO₂ and Et₂O to one cooled in liquid air.

The product would keep indefinitely at –190°, and no explosions occurred after the completion of the prepn., provided that all glass surfaces had been carefully cleaned with H₂CrO₄. There was, however, a slow decomp. of the vapour at room temp., N being liberated without change of vol., and a coherent white solid film deposited on the glass of the reaction vessel; this solid contained no N, hence we may assume the equation $n\text{CH}_2\text{N}_2 = (\text{CH}_2)_n + n\text{N}_2$ (cf. Bamberger and Tschirner, *Ber.*, 1900, **33**, 956). The stability of the samples of CH₂N₂ improved as the work progressed, and finally a sample of the vapour was obtained which still retained its yellow colour after storage in a glass bulb at room temp. for 8 months. This fact enabled light-absorption measurements to be made without serious errors due to deposited white solid.

The Absorption Spectrum of Diazomethane.—For the absorption spectrum in the visible and near ultra-violet region, the vapour was introduced at a measured press. into an evacuated 20-cm. SiO₂ tube, with plane and parallel ends. The photographs were taken with a Hilger E₁ spectrograph, using a 100-watt filament lamp as a "continuous" light source, and the iron arc to give a reference spectrum. When the press. of the vapour was 59 mm., the absorption was apparently continuous, beginning at 4400 Å.U. and extending into the ultra-violet, but at 250 mm. a number of weak and extremely diffuse bands appeared from about 4710 to 4250 Å.U., the wave-lengths of the bands being approximately as below, in Å.U. :

<i>ca.</i> 4710	4600—4570	4490—4460	4360—4340
4670—4630	4550—4520	4430—4390	4310—4250

None of the bands could be defined with precision, but the mean separation between their centres is *ca.* 66 Å.U. or about 300 cm.⁻¹. This diffuseness strongly suggests that we are here concerned with the phenomenon of predissociation. Beyond 4200 Å.U. the absorption was continuous, reaching a max. intensity at about 3950 Å.U. and then decreasing until at 3200 Å.U., the limit of transmission of the lamp, it was no longer perceptible. These facts are illustrated qualitatively in Fig. 1.

The absorption spectrum was examined in the further ultra-violet region with the aid of a large concave grating spectrograph of 3 m. focal length, a H discharge tube being used as a "continuous" light source. The absorption vessel was a 100-cm. SiO₂ tube, and exposures were made with CH₂N₂ pressures of 6 and 22 mm. The spectra showed a second region of absorption, beginning at 2650 Å.U. and rapidly becoming very intense towards shorter wave-lengths. At both pressures the absorption was continuous.

Since the spectrum consists of diffuse bands followed by a continuum, it is clear that the absorption of a light-quantum leads immediately to the dissociation of the molecule. The dissociation process which seems *a priori* the most probable is CH₂N₂ + hν = CH₂ + N₂. Calcn. from thermochemical data [the value of the C=C link being taken as 110 cal. (Sidgwick and Bowen, *loc. cit.*), and the heat of formation of C₂H₄ as -2.7 k.-cals.] shows that this process would require 64 cal./g.-mol., if CH₂N₂ were a thermo-neutral compound, but as it is certainly strongly endothermic, the energy of the quantum of wave-length 4710 Å.U. (60 cal./g.-mol.) is sufficient to effect the above dissociation.

FIG. 1.

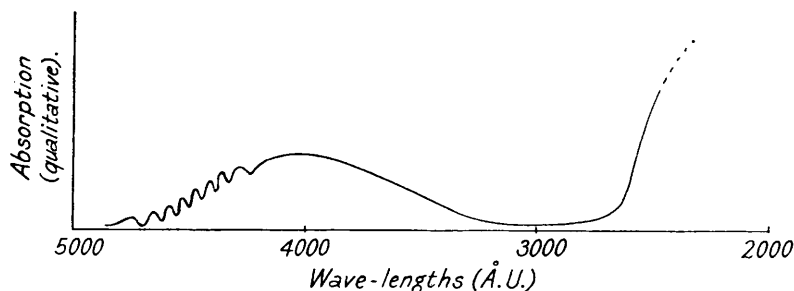

If, however, the ring formula for CH₂N₂ be accepted, dissociation involving rupture of the ring is also conceivable :

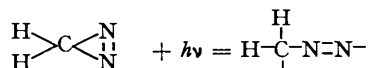

This process would require about 55 cal./g.-mol. to judge from the energy value of the C-N link in NH₂Me (Sidgwick and Bowen, *Ann. Reports*, 1931, 28, 367), but from the general behaviour of CH₂N₂ it does not seem likely that the process would occur without the simultaneous liberation of the internal energy of the mol. and the separation of a mol. of N₂, leading in effect to the former process, which therefore is to be taken as the most probable course of the optical dissociation of CH₂N₂. This conclusion is supported by the photochemical results (see below).

Comparison of the Spectrum of Diazomethane with that of Azomethane.—The CH₂N₂ spectrum was examined with a Nutting visual spectrophotometer, the vapour being contained in the 20-cm. SiO₂ tube at a press. of 300 mm. The extinction coefficients (ε) obtained have been plotted in Fig. 2, which also gives values obtained at 436, 405, and 365 mμ, with the apparatus illustrated in Fig. 4. The complete data on the spectrum may now be compared with those for azomethane (Ramsperger, *J. Amer. Chem. Soc.*, 1928, 50, 123).

	Diazomethane, CH ₂ N ₂ .	Azomethane, CH ₃ ·N ₂ ·CH ₃ .
Commencement of first absptn. region (Å.U.)...	4800	4050
Position of max. in this region (Å.U.)	3950	3400
End of first absptn. region (Å.U.)	3200	2800
Max. value of ε in first absptn. region	4.9	4.6
Commencement of second absptn. region (Å.U.)	2650	2600
Character of spectrum	Diffuse bands to 4250 Å.U., then continuous	Continuous*

* But since Ramsperger used a Hg arc as source, this merely signifies that the azomethane spectrum has no *marked* structure.

The close general resemblance between the two spectra is clear, and is in accordance with the supposition that the azo-group of azomethane is also present in CH_2N_2 . The evidence from the absorption spectrum therefore supports the ring formula for the latter.

FIG. 2.

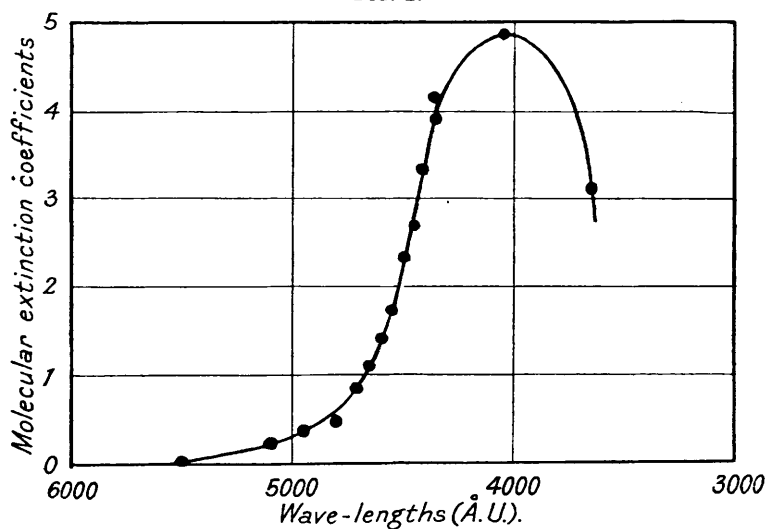
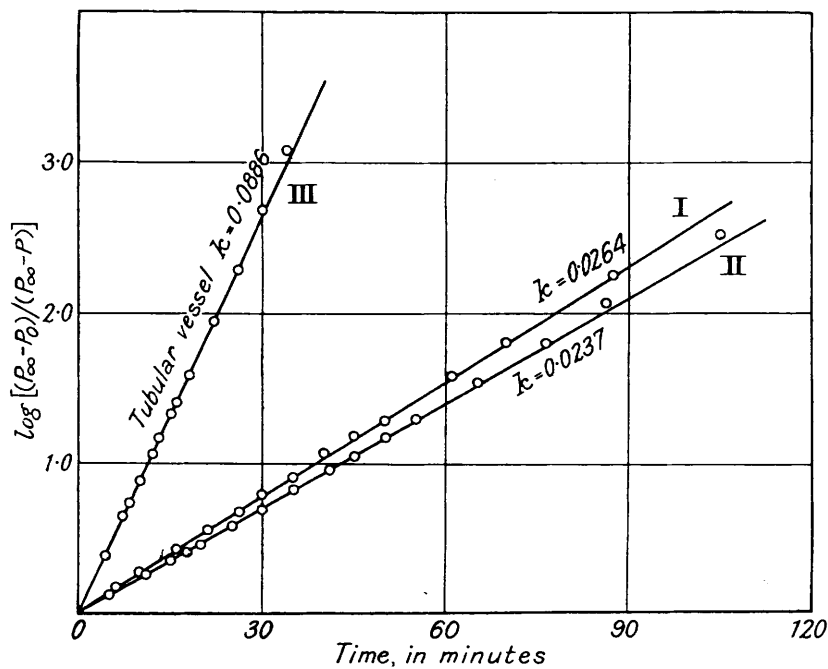

FIG. 3.



Initial press. of CH_2N_2 : (I) 104 mm., (II) 207.5 mm.

Photochemical Decomposition of Diazomethane.—Light from a Hg-vapour lamp, operated at const. voltage, was concentrated by means of a large lens on the reaction vessel, a bulb of 212 c.c. capacity. This was connected to a U-shaped manometer, and was maintained at 25° by immersion in a cylindrical vessel through which H_2O from an electrically regulated thermostat

was circulated. The apparatus was evacuated by a Hyvac pump, and the gaseous products of reaction collected by means of a Töpler pump.

Course of reaction. On illumination of the CH_2N_2 , at 100—200 mm. an immediate increase of press. set in: the yellow colour of the vapour gradually disappeared, and small brownish drops collected on the vessel walls. The press. increased in an accurately unimolecular manner to its final value, which was 25—30% more than the initial. This is illustrated in Fig. 3, which shows the straight lines obtained by plotting $\log_e (P_\infty - P_0)/(P_\infty - P)$ against t , P being the obs. press. at t min., P_0 and P_∞ respectively the initial and the final press., and k the vel. const.

The course of the reaction was also tested at lower press. With initial press. down to 12 mm., the reaction was still unimolecular, and the increase of press. was always between 26% and 30%.

An alternative arrangement of apparatus by which it was possible to obtain a much greater intensity gave very similar results. In this case a water-jacketed tubular reaction vessel situated close to the lamp, and maintained at 25°, was used, and although a much more rapid decomp. was obtained (see curve III of Fig. 3), the press. increase was of the same magnitude, and liquid drops formed as before.

In an attempt to initiate explosions the initial press. of CH_2N_2 was raised as high as 550 mm., with the same intense illumination, but in no case was an explosion observed. The tubular glass reaction vessel was then replaced by a similar vessel of silica, so as to admit light of wave-length corresponding to the second absorption region in the ultra-violet, the lamp being, as before, placed as close as possible; but although the decomp. occurred still more rapidly, it did not lose its unimolecular character, and the final press. increase of 27.6% showed that there was no change from the results obtained when light only of the longer wave-lengths was admitted.

Composition of the residual gases. The gaseous products of the reaction were passed through a trap cooled in liquid air and pumped out into a small gas burette of capacity 6 c.c., or, when larger quantities of gas were available, into a Lunge nitrometer which was used in conjunction with Hempel pipettes.

The fraction of the gas uncondensable at -190° comprised on the average 75.1% of the total gas from the reaction vessel. It was unaffected by the usual reagents, and it would not explode with O, but combustion over red-hot CuO showed that it contained 71.9 parts of N to 3.2 of CH_4 .

A further fraction (20.1% of the total gases) was obtained on warming the trap to -80° by means of solid CO_2 . Treatment with Br aq. showed that 88.5% of it consisted of olefins, and the remainder was shown by explosion with O to be C_2H_6 . Further samples of the fraction were then exploded with O (the C_2H_6 being present), and three closely concordant analyses showed that 37 of the 88.5 parts of olefin consisted of propylene, the remainder being C_2H_4 .

By warming the trap to 20° , the fraction of the residual gas condensable at -80° was found, from the press. it exerted, to amount to about 4% of the total gas, though it could not be pumped out, since it was absorbed by either the P_2O_5 in the Töpler pump or the moisture in the gas burette. It may have been a nitrogenous base.

The results of the gas analysis are summarised below, the figures indicating vols. relative to that of the initial CH_2N_2 as 100. They show that no simple equation can represent the course of the reaction.

Uncondensable	N, 91.3; CH_4 , 4.2.
Condensable at -190°	C_2H_4 , 13.1; C_2H_6 , 9.4; C_2H_6 , 3.0.
Condensable at -80°	6.1 (by diff.).

The liquid residue. The brownish liquid formed in the reaction vessel had a low v.p., since it remained after thorough evacuation with the Töpler pump. It was extracted from the reaction vessel with Et_2O and, after evaporation of Et_2O , had an amine-like odour, was readily sol. in acids, and gave with H_2O a weakly alk., cloudy solution. Lassaigne's test showed that it contained N, and when its alc. solution was treated with Na, NH_3 was evolved. It was therefore a weak nitrogenous base. Now, since Azzarelo (*Atti R. Accad. Lincei*, 1905, 14, ii, 286) found that C_2H_4 reacts with CH_2N_2 to give pyrazoline, presumably C_3H_6 would give a methylpyrazoline; further, the pyrazolines readily lose H to give the corresponding pyrazoles. It is therefore likely that the liquid residue consisted of a mixture of substances of this type.

Measurement of the Quantum Efficiency of the Reaction.—The apparatus used is illustrated in Fig. 4. The reaction vessel A, of fused SiO_2 , was connected to a sensitive glass Bourdon gauge

B, the pointer of which was observed through a travelling microscope. The general method of manipulation of the gauge was as described by Norrish (J., 1925, 127, 2316); it was calibrated to about 3% accuracy against a Hg manometer. H₂O from an electrically regulated thermostat was circulated through the outer jacket of the gauge, and also through the Cu tank *C*. The temp. of the gauge and of the bulb *A* were thus maintained const. at 25°.

The optical system consisted of a diaphragm fixed close to the lamp, a large quartz lens (focal length 10 cm.) at 11 cm. from this diaphragm, and a second diaphragm placed 12 cm. from the large lens. Immediately after this was the tank *C* (the windows of which were plane SiO₂ plates), followed by the smaller quartz lens *L*₂, which collected the light emerging from *C* into the Na photoelectric cell *P*. The electrical circuit and the method of calibration of this cell were as described in Part I (J., 1932, 1518).

To isolate monochromatic light of wave-length 436 mμ, the colour filter employed consisted of a plate of Co glass combined with a 0.5-cm. layer of 4% quinine hydrochloride aq. For 365 mμ, a Wratten No. 18a filter was used.

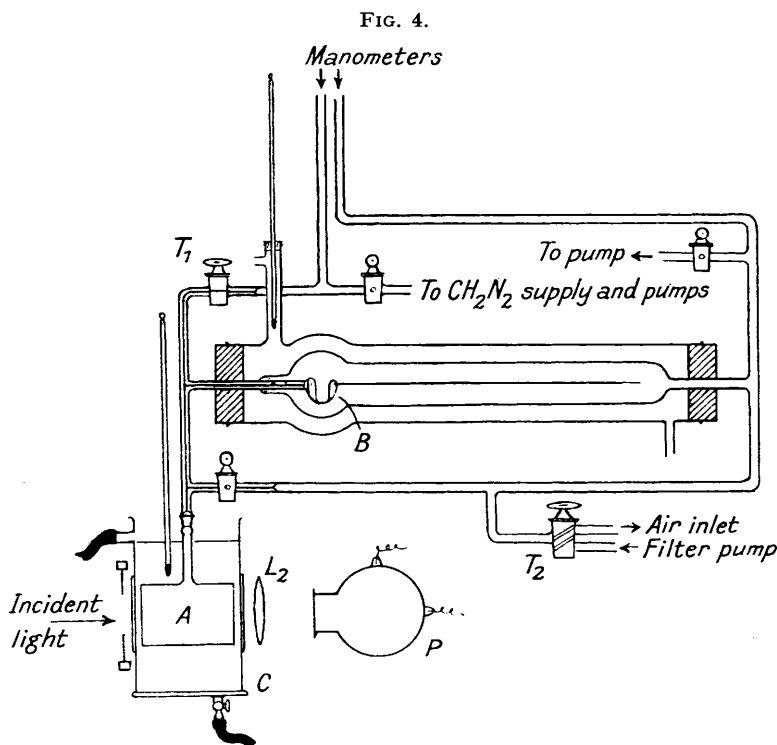

In carrying out a determination, the apparatus was first thoroughly evacuated with a Hyvac pump. Then the deflexion of the galvanometer connected to the photoelectric cell was recorded, and a shutter was inserted in the light beam. CH₂N₂ was admitted to *A*, and after the gauge pointer had been set to zero by manipulation of *T*₂, the manometers were read and illumination begun. The reading of the gauge pointer was recorded at intervals, and likewise the deflexion of the galvanometer. When the press. had increased by about 1 mm., the CH₂N₂ was pumped out and the galvanometer again read, so that the mean absorbed light flux could be calculated.

The pointer readings were plotted against time, and, since the reaction proceeded only to a relatively small extent, the points lay on a straight line, of which the slope gave the rate of press. increase.

It being assumed that an average press. increase of 27% indicates complete decomp. of the CH₂N₂, the rate of press. increase when multiplied by 100/27 = 3.7 gave the rate of decomp. in mm./sec. The capacity of the bulb and gauge having been found to be 68.7 c.c., the quantum efficiencies for light of 436 mμ and 365 mμ were calculated from the data recorded below.

	At 365 m μ .		At 436 m μ .	
Voltage of photoelectric cell	41		110	
Sensitivity (quanta/sec.) for 1 cm. defn.	1.27×10^{14}		2.40×10^{14}	
	I.	II.	I.	II.
Initial press. (mm. Hg)	148.5	200.6	208.5	202.5
Mean light absptn. (in cm. defn.)	5.1	6.05	2.63	2.92
Do. corr. for light losses	6.75	8.01	3.47	3.85
Do. do., in quanta/sec. $\times 10^{-14}$	8.55	10.1	8.32	9.2
Rate of press. increase (mm./min.)	0.0263	0.0333	0.0251	0.0277
Mols. decomp. per sec. $\times 10^{-15}$	3.63	4.60	3.47	3.83
Quantum efficiency, γ	4.23	4.53	4.2	4.2

The quantum efficiency thus lies between 4 and 5. The optical dissociation of the CH_2N_2 mol. must therefore be followed by a short chain of secondary reactions, involving on the average about 4 mols. of CH_2N_2 ; this is in accordance with the complex nature of the decomp. products.

Irradiation of Diazomethane in Presence of Hydrogen and of Oxygen.—The diffuseness of the spectrum of CH_2N_2 indicates that the primary photochemical process which follows the act of absorption is a dissociation of the mol., and the nature of the products of decomp. shows that this probably occurs according to the equation $\text{CH}_2\text{N}_2 + h\nu = \text{CH}_2 + \text{N}_2$; the actual final products of reaction may be supposed to arise from the action of CH_2 groups on unchanged CH_2N_2 mols.

It seemed that the correctness of this mechanism could be tested by carrying out the decomp. in the presence of H, which, by combining with the CH_2 groups to form CH_4 , should reduce the formation of olefins; this reduction would be coupled with a corresponding suppression of secondary reactions, so that a smaller formation of nitrogenous bases and a more nearly quant. yield of free N_2 would be obtained. Table I, which gives the results of the illumination at 25° of a mixture of equal vols. of the two gases, in comparison with those of the simple decomp. under the same conditions, shows that all these expectations were realised. The proportion of CH_4 and N increased, that of olefins diminished, and the nitrogenous liquid was no longer noticeable. (In the table, the vols. are given relative to that of the initial CH_2N_2 at S.T.P. as 100.)

TABLE I.

Initial press. of CH_2N_2 (at 25°), 100.1 mm.; H added, 100.3 mm.; final total press., 226.9 mm.

	In mixture.	In simple decomp.
Vol. of N_2 produced	97.0	91.3
" CH_4 "	14.0	4.2
" residual H_2	82.3	nil
Initial vol. of H_2	100.2	—
Vol. of H_2 consumed	17.9	—
" olefins produced	17.2	22.5
" C_2H_6 "	4.0	3.0
" C_3H_8 "	4.6	nil
Volatile substances condensable at -80°	2.6	6.1

Similar expts. were performed with mixtures of CH_2N_2 and carefully purified O; here the reaction was too rapid, and the press. increase too small, for the kinetics to be followed. The results of analysis of the gaseous products are in Table II, vols. being on the above basis.

TABLE II.

	I.	II.
Initial press. of CH_2N_2 (mm. at 25°)	60.0	120.7
" " O_2 added (mm.)	94.1	188.7
Relative vol. of O_2	156.7	156.5
Final press. increase, %	8.8	7.2
Vol. of residual O_2	117.6	117.0
" O_2 consumed	39.1	39.5
" CO produced	10.2	10.7
" N_2 "	101.8	101.0
" H_2 and CH_4 produced	trace	trace
" CO_2 produced	5.8	5.95
" C_2H_4 "	3.65	3.65

The N of the CH_2N_2 was thus quant. liberated as such, no oxides of N being formed, but the greater part of the C and H went into two liquid products. One of these was non-volatile, and sol. in H_2O to a weakly acid solution; the other had a v. p. of 48 mm. at 13°, did not freeze at

— 80°, and dissolved in H₂O to give a solution which coloured Schiff's reagent—it was thus probably aldehydic. These liquid products, together with the oxides of C, are undoubtedly the oxidation products of the CH₂ radicals. The quant. elimination of N shows that only the CH₂ radicals were attacked, and the results obtained, both in the hydrogenation and in the oxidation expts., therefore agree in supporting the conclusion that the primary photochemical process involves, not merely the rupture of the $\begin{array}{c} \text{H} \\ | \\ \text{H} \end{array} \text{C} \begin{array}{c} \text{N} \\ | \\ \text{N} \end{array}$ ring, but a complete dissociation according to the equation: $\text{CH}_2\text{N}_2 + h\nu = \text{CH}_2 + \text{N}_2$.

The formation of the final reaction products in the simple photochemical decomposition may be accounted for as follows:

(1) *Ethylene.* (a) $\text{CH}_2\text{N}_2 + h\nu = \text{CH}_2 + \text{N}_2$; (b) $\text{CH}_2 + \text{CH}_2\text{N}_2 = \text{C}_2\text{H}_4^* + \text{N}_2$, the C_2H_4^* afterwards losing its excitation energy by collision. These reactions give a value of 2 for γ , which, however, might be increased if the C_2H_4^* or N_2 molecules are sometimes able to dissociate another CH_2N_2 molecule by collision.

(2) *Propylene.* (a) and (b) as above, then (c) $\text{C}_2\text{H}_4^* + \text{CH}_2\text{N}_2 = \text{C}_3\text{H}_6 + \text{N}_2$, giving a value of 3 for γ .

(3) Some of the ethylene formed as in (1) may be supposed to yield pyrazoline: $\text{C}_2\text{H}_4 + \text{CH}_2\text{N}_2 = \text{C}_3\text{H}_6\text{N}_2$, giving a value of 3 for γ .

(4) Similarly, propylene formed as in (2) may be supposed to afford a methylpyrazoline: $\text{C}_3\text{H}_6 + \text{CH}_2\text{N}_2 = \text{C}_4\text{H}_8\text{N}_2$, giving a value of 4 for γ .

A calculation based on this scheme and on the percentage composition of the reaction products shows that the mean value of γ should be about 3. The observed value is approximately 4, and the discrepancy between the two is probably outside the limits of experimental error. We may therefore suppose that in a small proportion of instances the primary process is followed by a repeating chain such as is suggested under (1) above.

In conclusion, we suggest that the differences between the photochemical and the thermal decomposition of diazomethane are to be explained by ascribing to the latter a reaction mechanism involving, not free radicals, but excited molecules which are produced in bimolecular collisions, and react directly thus: $\text{CH}_2\text{N}_2^* + \text{CH}_2\text{N}_2 = \text{C}_2\text{H}_4 + 2\text{N}_2$. The explosions occurring at temperatures and pressures above certain limiting values are presumably due to branching reaction chains, initiated with the aid of the energy of the ethylene and nitrogen molecules first formed. The absence of explosions in the photochemical reaction may be due to the expenditure of the energy of decomposition in the synthesis of complex products.

SUMMARY.

1. The absorption spectrum of diazomethane vapour shows two absorption regions; the first, from 4710 Å.U. to 3200 Å.U., consists of diffuse bands followed by a continuum, and the second, beginning at 2650 Å.U., is completely continuous. The general character of the spectrum supports the formula $\begin{array}{c} \text{H} \\ | \\ \text{H} \end{array} \text{C} \begin{array}{c} \text{N} \\ | \\ \text{N} \end{array}$ for diazomethane.

2. The photochemical decomposition of diazomethane has been found to be kinetically a unimolecular reaction in which the main products are nitrogen, ethylene, propylene, and a non-volatile liquid which is possibly a pyrazoline derivative. The quantum efficiency is approximately 4 at both 365 and 436 m μ .

3. From the above facts, and from the photochemical behaviour of mixtures of diazomethane with hydrogen and with oxygen, it is concluded that the primary process in the photochemical decomposition is $\text{CH}_2\text{N}_2 + h\nu = \text{CH}_2 + \text{N}_2$. The formation of the actual reaction products is readily explained in terms of subsequent secondary processes.

The authors thank the Government Grant Committee of the Royal Society, Emmanuel College, and the Department of Scientific and Industrial Research for grants.