

139. *Studies in the Mechanism of Flame Movement. Part III. The Speed of Flame in Currents of Mixtures of Methane and Air.*

By H. F. COWARD and E. H. M. GEORGESON.

It was shown by Mason and Wheeler (J., 1920, 117, 1227) that, when a 6.35% methane-air mixture was fed through safety gauzes into a tube, the far end of which was open,

FIG. 1.

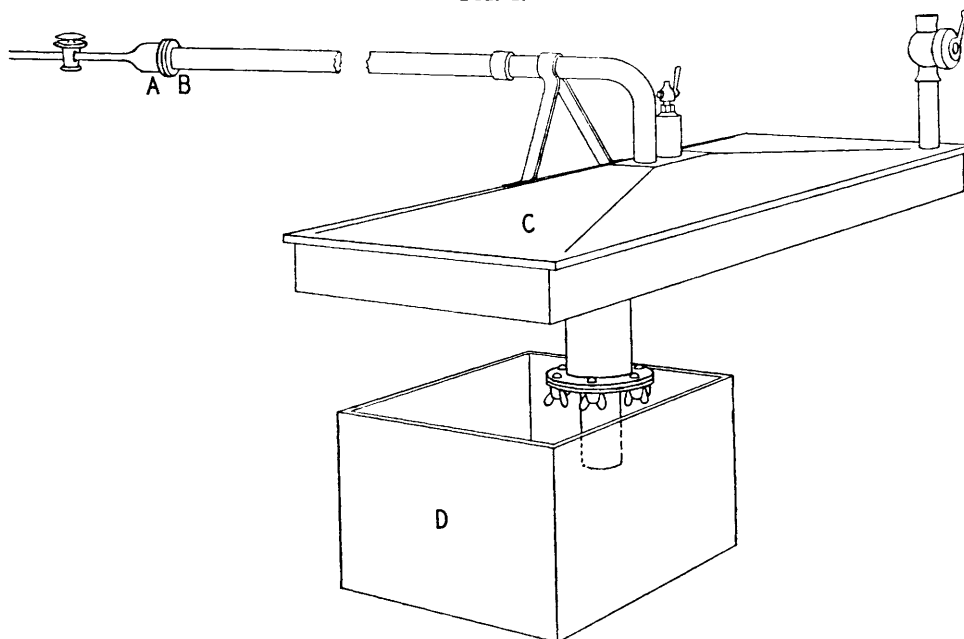

and was ignited near the gauze, the speed of flame was much greater than the sum of the speeds of the current and the flame in a still mixture. The results are difficult to analyse, for, besides the flame which travelled from the igniting spark in the direction of the current of gas, a second flame must have travelled against the current towards the gauze. The expansion due to the second flame would accelerate the current in which the first flame was travelling. The amount of such acceleration was not ascertainable, and therefore the effect of the current primarily imposed could not be isolated from the effect of the current due to the second flame.

Experiments were therefore designed so that only one flame should be propagated in the explosive mixture. In one series the mixture was ignited at the open end of a tube,

and was at once put into motion by starting a water piston at the far end of the tube. In these circumstances the flame travelled in the usual manner from the open towards the closed end of a tube; *i.e.*, a period of uniform movement was followed by vibrations which persisted until the flame reached the piston head.

In another series of experiments the mixture was ignited at the head of a moving piston and flame travelled towards the open end of the tube. In such circumstances the speed of flame is much higher than in the uniform movement, in parallel experiments, on account of the increase in volume during combustion.

The explosion tube, 2.25 m. long, 2.45 cm. internal diam., was fixed horizontally. In the first series of expts. the flanged ignition end, *B* (Fig. 1), was closed, until a moment before ignition, by a sliding cover, *A*, fitted with a tube for the introduction of gas mixtures. The other end, bent downwards, terminated at the head of a wide shallow water-tank, *C*. Interchangeable pipe orifices, dipping into a constant-level reservoir, *D*, served to adjust the rate of flow of H₂O from the tank, thereby controlling the speed of current of the explosive mixture in the tube.

The rate of flow of H₂O from the tank, *C*, under the conditions of the flame expts. was determined from measurements of the times of discharge of known vols. of water, from *C* to *D*, under measured press. heads before and after the H₂O flowed.

The speed of an explosion was obtained by photographing the flame on bromide paper mounted on a motor-driven rotating drum. The speed of the drum during the explosion was recorded on the paper by photographs of break-sparks produced by a standard tuning-fork. A section of the explosion tube was of clear quartz, covered with black paper with a slit, 26 cm. long and 6 mm. wide, opposite the camera.

For each expt. the pipe orifice of the tank, *C*, was closed by a rubber bung, the tank was nearly filled with H₂O, and the explosion tube was then filled with a CH₄-air mixture by displacement through the central tap of the tank. When the drum of the camera was

revolving at const. speed, the sliding cover at the firing end of the tube was gently removed and the mixture was ignited by a spark passed between terminals 1.3 cm. within the tube. Immediately afterwards, the current of gas was started by removing the stopper of the pipe orifice of the tank.

Preliminary trials proved that there was no difficulty in starting the current of mixture at the desired moment. By a slight delay in opening the pipe orifice, it was easy to obtain a photograph showing (1) uniform movement of flame in the still mixture, (2) acceleration of the flame by the current, and (3) uniform speed of the flame when the current was fully established. The second stage was so short that no curvature was to be seen where the straight-line records of stages (1) and (3) met; but the transition was not sharp enough to create pressure waves affecting the flame record.

Mean and Maximum Speeds of Current.—Kohlrausch (*Ann. Physik*, 1914, **44**, 297) determined the approx. velocity distribution curves, in a tube of 2.98 cm. diam., for currents of gas of mean speed from 31 to 225 cm./sec. Similar results being assumed for the 2.45-cm. tube used in the present expts., the relative mean and max. speeds of the currents used were :

Mean speed, cm./sec.	15	31	45	67	113	200	404
Maximum (axial) speed	(29)	60	78	106	161	265	(531)

(The figures in parentheses are extrapolations.)

FIG. 2.
Speed of uniform movement of flame in currents of mixtures of methane and air.

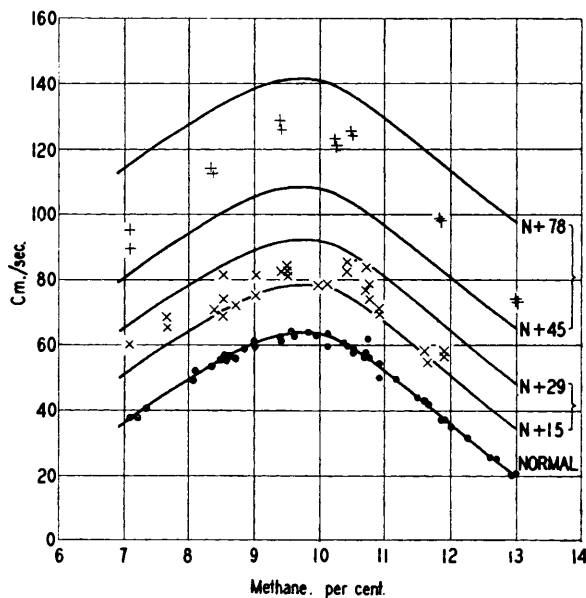

Influence of Currents on the Speed of Uniform Movement of Flame.—Fig. 2 shows the influence, on the speed of uniform movement of flame in CH_4 -air mixtures in a 2.45-cm. tube, of imparting to the mixtures mean speeds of 15 and 45 cm./sec. The lowest curve represents the speed of uniform movement in still mixtures in the same tube; this is called the normal speed, N . The curve $N + 15$ is the normal speed curve, *plus* 15, and therefore represents the speeds that would be observed if the speeds of uniform movement in a current of mean speed 15 cm./sec. were equal to the normal speed *plus* the mean speed of the current. The curve $N + 29$, similarly drawn, represents the speeds of flame that would be observed if the speeds

FIG. 3.

Effect of currents on the speed of uniform movement of flame in mixtures of methane and air.

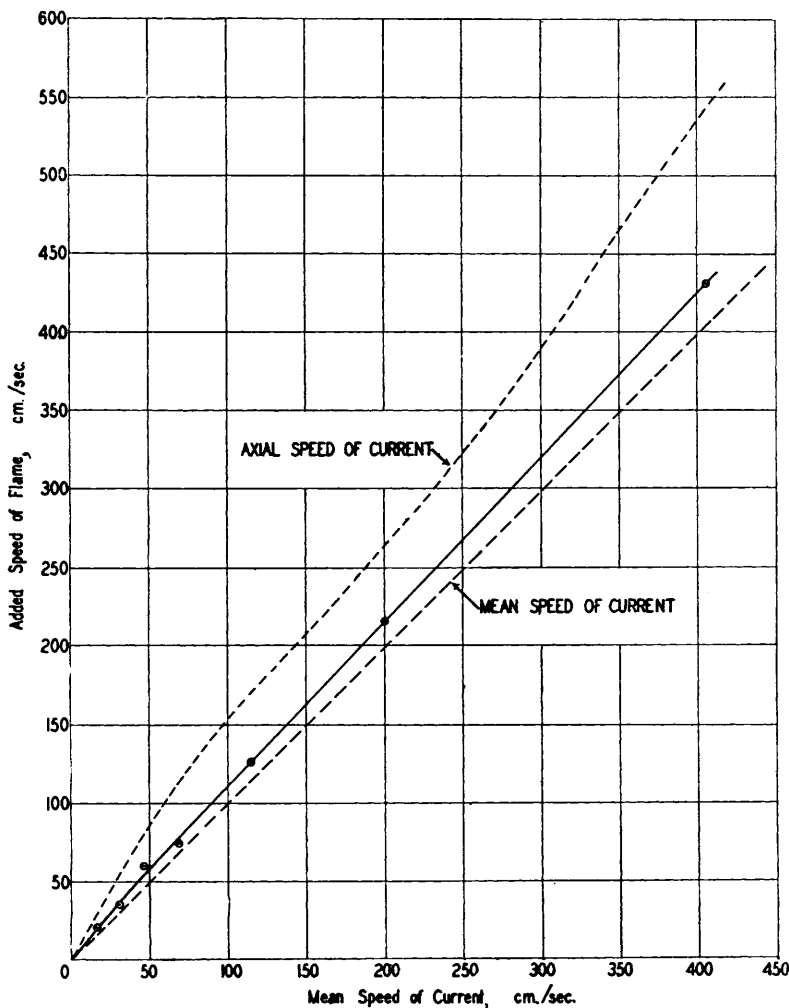

of uniform movement in the same current were equal to the normal speed *plus* the maximum (axial) speed of current. The flame-speed measurements in the currents were not so closely reproducible as those in the still mixtures, but almost all of them lie between the two curves. The mean difference in flame speed, due to the current, is 19.5 cm./sec.

Similar results were obtained in 22 measurements of flame speeds in current speeds of 31 cm./sec., 14 at 45 cm./sec., 8 at 67 cm./sec., 15 at 113 cm./sec., 13 at 200 cm./sec., and 4 at 404 cm./sec.

Fig. 3 summarises these results. It shows that, for the range of mixtures and speeds of current investigated, the average increase in speed of flame due to the current is rather greater

than the mean speed of current over the whole section of the tube, and less than the maximum (axial) speed of current.

With care, stream-line flow would occur, in the tube used, at speeds of current below about 130 cm./sec. Turbulent flow occurs at greater speeds. In these expts., stream-line flow was probably never obtained; or, if so, it was probably not maintained in the vicinity of the flame.

Influence of Currents on the Mean Speed of Flame in Vibratory Movement.—In all but the slowest-burning mixtures, the uniform movement of flame gives place to a vibratory movement when flame has travelled about $\frac{1}{4}$ or $\frac{1}{3}$ of the length of the tube from the open to the closed end. During the vibratory movement the mean (algebraic) forward speed of flame is greater than that of the uniform movement. The transition is usually not sudden, for a gentle undulatory movement may be observed, during which the mean speed of flame is equal to, or less than, that of the uniform movement. The mean speed of the subsequent vibratory movement is fairly well reproduced in successive expts., but not so closely as the speed of uniform movement.

Measurements which show the influence of currents on the mean speed of flame in vibratory movement, as the flame passed a window in the tube extending between 120 and 146 cm. from the open end, are plotted in Fig. 4. It may be questioned whether a fixed part of the tube is a proper choice for the comparison, or whether it would be correct to employ that part of the tube through which the flame passed at an equal interval of time after ignition. In favour of the latter choice is the supposition that in currents of various speeds the uniform movement would persist for about equal periods of time. Experiment showed that this was not so, for in a still mixture the uniform movement persisted over a length of about 70 cm. during an interval of about 1.1 sec.; but, when currents of 113 and 195 cm./sec. were used, the vibratory movement was quite definite opposite the window as placed, although the flame passed the window less than 1.1 sec. after ignition. The choice of a fixed distance appears therefore to be preferable to that of a fixed time after ignition.

Fig. 4 shows that, when the more explosive CH_4 -air mixtures were moving as currents in a 1-in. tube, the increase in mean speed of flame during the vibratory movement was somewhat greater than the mean speed of the current, but less than the axial speed, when the currents were 113, 195, and 404 cm./sec. When the current was 37 cm./sec., the speed of flame was not increased by as much as 37 cm./sec. A similar result was obtained in a series of 18 measurements of the speeds of vibratory movement in a 10% mixture when the current was 25 cm./sec.; the mean increase in flame speed due to the current was only 7 cm./sec. Fig. 5 summarises these results. Although the individual results recorded in Fig. 4 were not so

o o

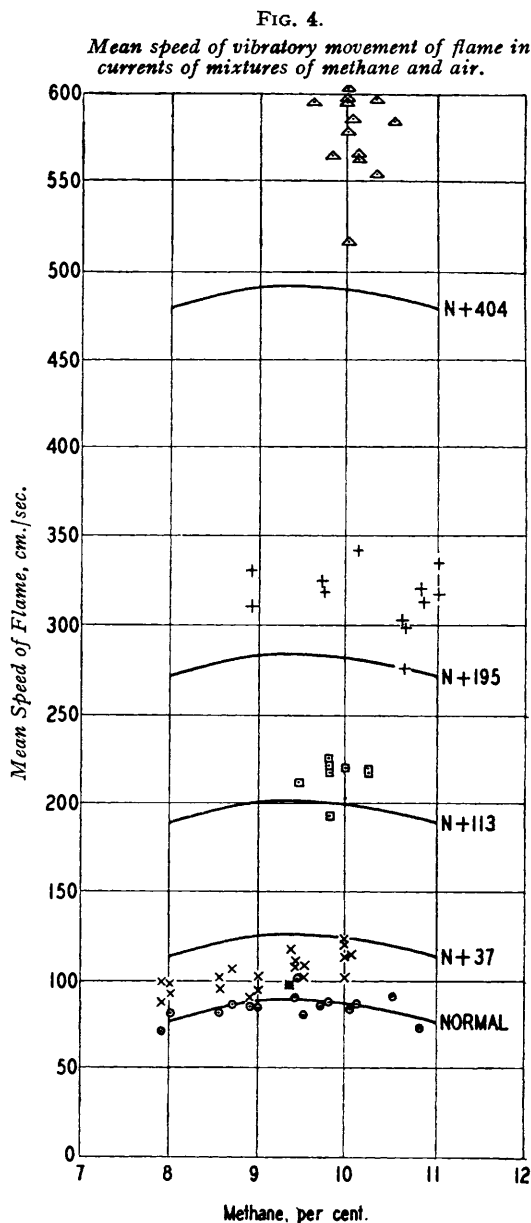

consistent as was desired, the averages for each speed lie close to a straight line drawn on Fig. 5.

Influence of Currents on Rapidly Moving Flames.—The results so far described relate to the comparatively slow propagation of flame in mixtures ignited at the open end of a tube closed at its other end. An examination was next made of the effect of currents on the much faster explosions obtained when mixtures are ignited at the closed end of a tube open at its far end.

In order to create the desired current, a piston, the face of which formed the closed end of the tube, was forced along a short brass firing end of a glass tube 1 m. long and of 2.5 cm.

FIG. 5.

Effect of currents on the mean speed of vibratory movement of flame in mixtures of methane and air.

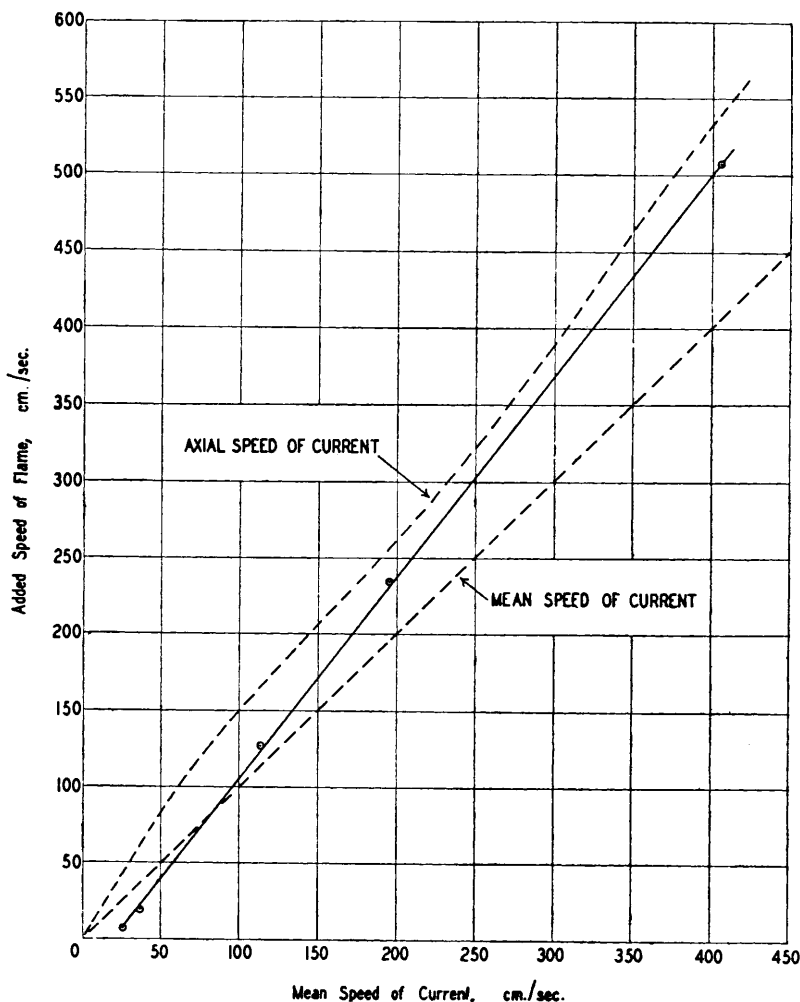

internal diam. The gas mixture was fired by means of a spark gap on the head of the piston; a spark was produced automatically when the piston had travelled 4 cm. along the firing piece.

The mechanical difficulties of imparting a uniform speed to the piston were considerable, and attempts to create a uniform current of the order of the explosion speeds (20–40 m./sec.) were failures. Uniform currents of 35, 70, and 150 cm./sec. were, however, ultimately produced. The piston was drawn along the tube by two flexible cords, external to the tube, attached to a light frame-work moving in guides. These cords were then strung through two holes in a brass ring cross-head. A loop of thread was passed through two other holes in

the ring, and to this loop was attached a single line, tightly knitted in a small cylinder, with its far end wound on a bobbin driven by a 0.25 h.p. Century motor. When the motor was started from rest, it first unravelled several yards of the line. Then, when the motor had attained its full speed, the piston was pulled forward. Rigidly attached to the piston-rod was a pen which registered the speed of the piston by tracing a path on paper mounted on a revolving drum. These records showed that for the first 2 or 3 cm. of travel there was a somewhat jerky acceleration, but that afterwards the forward motion of the piston was sensibly constant.

Direct photography of the flames of these fast explosions was impossible, for their actinic value is small, but good shadow photographs were obtained on a revolving-film camera. These showed that, while the piston was moving uniformly, or when it was stationary, the flame travelled with sensibly uniform speed in any one expt. over most of the length between 11 and 30 cm. from the piston head. Thereafter the flame halted momentarily, and then completed its passage in a series of rapid forward movements alternated with halts. Each photograph showed a complicated flame surface during the halt period. It was, therefore, not surprising to find that the flame-speed measurements, even in the forward movement, were far from being accurately reproducible. The differences in flame speeds observed in expts., repeated under apparently the same conditions, were much greater than the speeds of current used. The only conclusion that can be drawn, from 118 expts., is that the speed of the flame was not far greater than the sum of the speed of the current and the speed of flame in the absence of a superimposed current. This limited conclusion is, however, of some value, for it supports the interpretation, given in the opening paragraph of this paper, of the very high speeds observed by Mason and Wheeler (*loc. cit.*) in the conditions of their expts. with currents of gases. Moreover, it is a reasonable conclusion, for in the conditions of our expts. with rapid flames, the expanding gaseous products created such a current that the superposed currents can have made relatively little difference to the speed of the medium near the flame.

SUMMARY AND CONCLUSIONS.

The speeds of flame in various mixtures of methane and air moving as currents in a glass tube 2.45 cm. in diameter have been determined. Special devices were used to ensure that flame should travel in only one direction along the tube.

The results show that in the propagation of flame from the open to the closed end of a tube, the increase in speed of uniform movement due to the current was greater than the mean speed of current, but less than the axial speed. The increase in mean forward speed during the vibratory movement was in general somewhat greater than the mean speed of current, but less than the axial speed; for small currents, however, the increase in speed was less than the mean speed of current.

In the propagation of flame from the closed to the open end of a tube, the speed of flame is high and the results were irregular; but the effect of the current was not to increase the speed of flame inordinately.

The authors thank the Safety in Mines Research Board for permission to publish this communication.

SAFETY IN MINES RESEARCH BOARD LABORATORIES,
SHEFFIELD.

[Received, February 8th, 1933.]
