

262. *The Isotopic Ratio in Hydrogen: A General Survey by Precise Density Comparisons upon Water from Various Sources.*

By H. J. EMELÉUS, F. W. JAMES, A. KING, T. G. PEARSON, R. H. PURCELL, and
H. V. A. BRISCOE.

THE discovery of the isotope of hydrogen of mass 2.0135 immediately raised the question of the abundance ratio of the isotopes of this element in its naturally occurring compounds. Although the general concordance between determinations of the atomic weight of an element from widely different terrestrial and even meteoric sources in a number of cases (summarised by Aston, "Mass-Spectra and Isotopes," 1933, p. 186) has confirmed the earlier opinion (*idem*, "Isotopes," 1922, p. 113) that the evolution of the elements has been such as to lead to a constant proportion of the isotopes in all specimens, yet there remains the possibility of natural separation in a few light elements, in which the difference in mass between the isotopes is proportionately large and may be attended by slight physical and chemical differences.

Evidently hydrogen is a peculiarly favourable case for the observation of such changes. It is true that the separation is rendered more difficult by the smallness of the proportion of the heavier isotope normally present; but, on the other hand, hydrogen lends itself well to investigation, not only because of its wide distribution in the combined state, but also because of the facility with which it can be obtained as, or converted into, water. The isotopic ratio in the carefully purified specimen is then readily deduced from density determinations.

Since accurate comparisons of density, rather than absolute determinations, are needed, these have been made by the method of flotation, which is the most precise for this purpose, giving comparative values more accurately than do pyknometric methods.

The apparent ease with which water can be purified and its density determined tends, however, to obscure two possible sources of error, which, because of the precision of the flotation method, became apparent in our preliminary work, and have therefore been thoroughly investigated.

Methods of purification which are satisfactory even for conductivity determinations or atomic weight work, are inadequate for the present purpose; more rigorous methods were therefore devised and tested. Secondly, there is the great difficulty of finding a source of water suitable for use as a standard of density. "Conductivity water" prepared in the usual manner, shows large variations in density, and since pyknometric determinations are in fact also comparative, it seems curious that none of the several such determinations recently published makes any reference to this difficulty. After a great deal of work, involving the abandonment of earlier standards and the redetermination of the densities of many of our samples, it was found that samples of pure water prepared from London tap water, as delivered at South Kensington by the Metropolitan Water Board, were, so far as our measurements could detect, constant in density throughout the period of the investigation (October 1933 to April 1934). This water was accordingly adopted as the standard.

In discussing small differences of density of the order here involved the ordinary unit is inconveniently large. We therefore adopt the device current in microchemistry and call one millionth of the ordinary unit a *gamma* of density: $0.000,001\Delta d = 1\gamma d$. The error of our comparisons is $\pm 2 \times 10^{-7}$ g./c.c. or $0.2\gamma d$, and this permits the detection of a change

of about 2 parts per million in the isotopic ratio of hydrogen. More than 70 samples of water were examined from animal, vegetable, and mineral sources. The significance of the results can hardly be appreciated unless by such individual consideration as follows later, but it may be said here that, while a majority of them had densities near that of the standard, many showed definite differences therefrom of as much as 2.5, 8.6, and 6.3 γ *d* respectively for the sources named.

A survey of samples from various industrial processes and sources not involving electrolysis showed similar variations, with the maximum values -5.0 and $+4.6\gamma$ *d*. On the other hand, waters from electrolytic plants of various types showed much larger variations from the standard density, amounting in the case of one sample, from an oxygen generating plant, to $+30\gamma$ *d*.

In every case so far examined, it has been possible to account for the observed density differences, at least qualitatively, by the operation of some physical or chemical process capable of changing the isotopic ratio in the observed direction. The survey therefore affords no evidence that in the absence of such local influences the abundance ratio of the hydrogen isotopes is variable with the source.

To elucidate this point further, we have included in our survey samples obtained by subjecting water fractionally to various physicochemical processes, such as distillation, freezing and melting, adsorption, and combination in salt hydrates, and have found that under suitable conditions any one of these processes except the last-named can effect an appreciable separation of the isotopes.

EXPERIMENTAL.

Purification of Samples.—The nature of the impurities present varied widely from sample to sample. Distillates from natural hydrated minerals were relatively pure, saline waters from inland seas less so, and the oily sludges of the gas industry presented a very serious problem. Whereas the removal of salts was easily and completely effected by properly arranged distillation, it was necessary to destroy organic impurities by chemical means, since fractional distillation was inadmissible because of its effect on the isotopic ratio (p. 1219).

At the same time it is evidently desirable that the process of purification should, in all essentials, be the same for all samples. After much preliminary work, the following scheme was adopted for all the samples here reported. In processes (b), (d), (h), and (i), small equal head and tail fractions were rejected. (a) Filter from suspended matter. (b) Distil. (c) Boil under reflux with excess of potassium permanganate, usually with sodium peroxide, but, in certain special cases where organic bases were present, with sulphuric acid. (d) Distil from the permanganate. (e) Repeat (c) and (d) until no further reduction of permanganate was noticeable. (f) Distil with a stream of oxygen through cupric oxide (from wire) kept at 800° in an electrically heated silica-tube furnace. (g) Boil under reflux with a small quantity of potassium permanganate and caustic potash. (h) Distil from the permanganate. (i) Redistil through a special spray trap in an apparatus wholly of Pyrex glass with ground joints. (j) Remove dissolved gases by boiling in a vacuum.

In some cases special treatments were added to this procedure; *e.g.*, milk was first treated with sulphuric acid to precipitate the casein, while blood had a preliminary wet oxidation with potassium permanganate and phosphoric acid to destroy the bulk of the organic matter. Special importance is attached to the high-temperature oxidation (f) of all samples, because we repeatedly found that it was thus possible to destroy impurities which were extremely resistant to wet oxidation. It is our considered opinion that any purification dependent wholly upon wet oxidation must, in many instances, be untrustworthy.

All apparatus used in the purification process was of Pyrex glass or silica. In those cases where the joints were not ground, they were made with tin foil, so that neither water nor water vapour made contact with any surface other than tin, Pyrex glass, or silica. The glass and quartz vessels were first freed from grease by means of hot chromic-nitric acid solution, then extracted for at least 24 hours with concentrated nitric acid at 100°, rinsed thoroughly with freshly distilled water, thoroughly steamed in an inverted position over the generator shown in Fig. 1, dried at 110° in an air-oven specially reserved for this purpose, and then used immediately.

The dry-oxidation process [stage (f)] was effected in the apparatus shown in Fig. 2. Oxygen from a cylinder and steam from the Claisen flask *A* were led directly into the 2-inch-bore, glazed Vitreosil tube *B*, which carried a nichrome winding and was heavily insulated with asbestos.

The joint between flask and furnace, made by a cork covered with tin-foil, was cooled by circulating water in a spiral of metallic tubing *C* and protected from radiant heat by an asbestos shield just within the furnace. In the heated portion, some 10—12 inches in length, the tube was packed with copper oxide (from wire) the silica being protected from reaction therewith by a

FIG. 1.

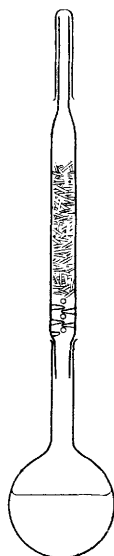
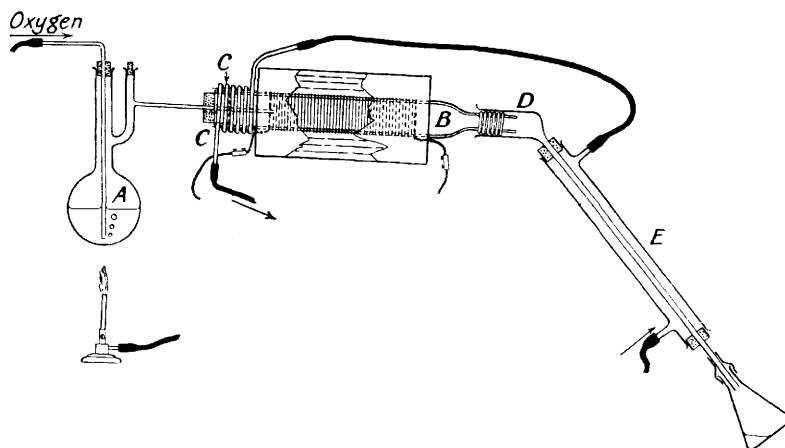

FIG. 2.



lining of asbestos paper. Beyond the heating element, the furnace tube was drawn down to about $\frac{3}{4}$ inch external diameter, and at the exit made a sliding fit into the Pyrex adaptor *D* which led directly to the condenser *E*.

Before use, the furnace was kept for several hours at its maximum temperature, 800° , in a current of oxygen, and then the sample, often about 500 c.c., was distilled through it with oxygen in the manner already described.

Refluxing with, and distillation from, permanganate (stages *c*, *d*, *e*, *g*, and *h*) were carried out in the apparatus shown in Fig. 3, so constructed (of Pyrex, with ground joints) that steam from the sample in *A*, scrubbed thoroughly from spray in the column *B* which is packed with glass rings 4 mm. \times 4 mm., may be condensed and returned with the condenser in the higher position (refluxing) or collected as a distillate by turning the condenser into the lower position. The final distillate in each case was kept in a Pyrex flask (previously extracted with acid and steamed thoroughly) and protected by a cap of tin foil.

To test the efficacy of the purification process, samples of pure water of known density relative to the standard were purposely contaminated and then re-purified. In one case, 500 c.c. of water were contaminated by adding 2 g. of phenol, 1 g. of benzene, and 1 c.c. of pump oil; and in another, the added contamination comprised 1 g. of sodium chloride, 2 g. of potassium tartrate, 1 g. of methyl acetate, 2 g. of phenol, 1 g. of benzene, 3 g. of pyridine, and 1 c.c. of very dirty pump oil. After purification the densities of both samples agreed with that of the original water within $0.2\gamma d$.

In the course of the work other proofs of the soundness of the purification process were obtained; *e.g.*, the density of a sample of "conductivity" water prepared from tap-water was measured first as delivered from the still and then after going through all the stages of purification:

FIG. 3.

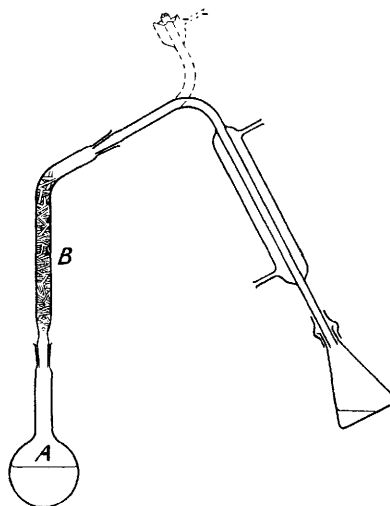

the results agreed within $0.2\gamma d$, and this affords a satisfactory (and essential) proof that the purification process does not of itself produce any detectable change in the isotopic ratio.

With such a sample, obviously, the dry oxidation over copper oxide at 800° might be omitted, but it was always employed for the sake of uniformity. How necessary it was for many of the specimens can be illustrated by a few examples. Several of the fruit-juice samples, which one might regard as being very amenable to wet oxidation, were measured both before and after the copper oxide treatment. It was found that the omission of dry oxidation left impurity in the water sufficient to produce a density difference from the true value of as much as $1.2\gamma d$. With samples containing difficultly oxidisable sulphur or nitrogen compounds, permanganate oxidation alone proved quite insufficient to purify the water completely, and, indeed, in certain intractable cases as many as four copper oxide combustions were necessary to obtain pure water, as judged by its attaining constant density. A case in point is the water from rhubarb, which gave the following flotation temperatures after four successive applications of the treatments (f) to (j) inclusive : (1) 20.383° , (2) 20.342° , (3) 20.335° , (4) 20.335° . Similar difficulty was experienced with milk, blood, bile, urine, tomatoes, and pineapples.

We direct special attention to this point because it is evidently important that others engaged in the examination of waters from various sources should realise how essential a dry combustion may be, even in unexpected cases like some of those cited above. The samples after thorough wet oxidation appear to be perfectly pure; they are colourless, odourless, and without any

FIG. 4.



FIG. 5.

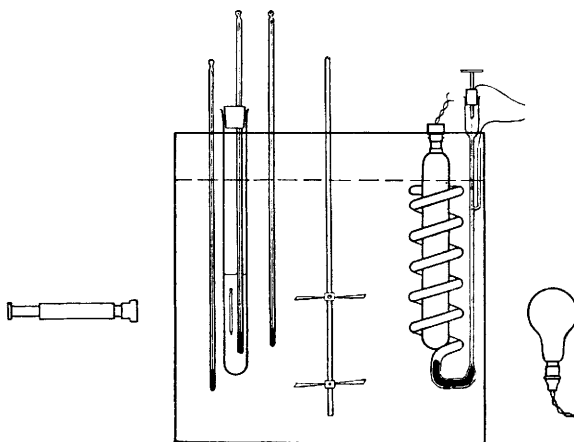

action on permanganate, and we might easily have accepted them as being pure at this stage but for the fact that the nature of certain industrial samples, such as "devil liquor" and phenol distillates, had forced us to include the dry oxidation in our scheme.

Density Determinations.—A critical consideration of the methods available for precise determinations led us to adopt the method of flotation, which was used for accurate measurements of the density of ice 72 years ago (Dufour, *Compt. rend.*, 1862, **24**, 1080) and was later developed to a high degree of precision by Richards and his collaborators (Richards and Shipley, *J. Amer. Chem. Soc.*, 1912, **34**, 599; 1914, **36**, 1; Richards and Harris, *ibid.*, 1916, **38**, 1000). The method consists essentially in observing directly the *temperature* at which a float completely immersed in the liquid remains exactly suspended, neither rising nor falling. The coefficient of expansion of the liquid being known, a second similar observation with the same float in the standard liquid gives a direct comparison of the densities. Evidently the chief requirement is a float of convenient density, unchanging in size and weight and insoluble in the liquid. The only other requisites are insoluble containing vessels for the liquid, accurate thermometry, and a thermostat capable of holding a temperature constant within the error of the thermometry and yet adjustable in temperature over a range of several degrees.

Floats. Fused silica is the ideal material for floats because of its small thermal expansion, great elasticity, mechanical strength, permanence, and complete insolubility (Richards and Harris, *loc. cit.*). The design of the float is of some importance. Whereas Richards and Shipley (*loc. cit.*, 1912) advocated a fish-like form, we have found that a slim cylindrical float (Fig. 4) is

preferable, since its movement responds more rapidly and certainly to small differences in the density of the liquid. The floats used were about 75 mm. long \times 4 mm. in diameter, and had a ring at the top so that they could be handled conveniently by means of a glass hook.

Richards and Harris (*loc. cit.*, p. 1001) found that their floats changed considerably in density with time; ours, however, showed no change whatever in 5 months, although they were constantly under observation from the day they were made. This is probably a consequence of the fact that our floats, being drawn from 4-mm. silica tubing, were worked only at the ends, whereas Richards's floats were evidently worked in the making over their whole surface.

Flotation vessels. The containers used for the flotation temperature determinations were large test-tubes of the form shown in Fig. 4, provided with ground-in stoppers which served as spray traps during the out-gassing of the liquid by boiling in a vacuum. They were made of Pyrex glass. Richards and Shipley (*loc. cit.*) have shown that borosilicate glasses are not appreciably dissolved by water, even after 2 months' standing, and we have found repeatedly in the course of this investigation that water can be kept for some days in vessels of Pyrex or in Jena resistance glass without measurable change in density.

After preliminary cleansing with hot chromic-nitric acid, the tubes were extracted with nitric acid at 100° for 24 hours, and then thoroughly washed and steamed. On each subsequent occasion of use, they were first treated with nitric acid at 100° for one hour and then washed and steamed.

Thermometry. In general, flotation temperatures were determined by mercury-in-glass thermometers specially made for this work by Messrs. Calderara, London. They had a range of 10° (12—22°) and were graduated in 0.02°, these graduations being so spaced (about 1 mm. apart) that it was possible, with the aid of suitable magnifiers, to estimate the temperature within $\pm 0.001^\circ$. This accuracy of reading was repeatedly checked by getting two or more independent observers to read the same steady temperature.

Three such thermometers were used in each observation, two in the thermostat bath and one in the sample, and they were frequently checked against each other. During the whole course of the first four months of the work the maximum observed discrepancy between them was 0.003°, and this value was attained only on a few occasions. Later, one of the thermometers suddenly changed and then read constantly 0.005° lower than the other two. As a check, therefore, a highly sensitive platinum resistance thermometer was constructed (with the kind co-operation of Prof. Gregory of the Physics Department of this College), which, used in conjunction with a special bridge (F. E. Smith's "difference bridge") and a galvanometer sensitive to 0.001 microamp., gave readings of temperature which could be duplicated within 0.0005°. When the mercurial thermometers were compared with the resistance thermometer (allowance being made, of course, for the effect of pressure on the former) the results agreed within $\pm 0.001^\circ$. It seems justifiable to assume, therefore, that the error of the temperature determinations in general does not exceed this amount. This is important because, as will appear later, the precision of the density comparisons is essentially that of the comparison of flotation temperatures.

Thermostat. A thermostat of 20 l. capacity was used, the temperature of which could be set to $\pm 0.001^\circ$ and automatically held within the same limits. In practice the temperature of the sample never varied by an amount appreciable on the mercurial or platinum thermometers.

Measurements. The containing vessel, cleansed as already described, was rinsed with three small portions of the sample to be measured, and then 150 c.c. of the sample were introduced, the stopper, connected to a water pump, was pushed home, and the sample was thoroughly out-gassed by boiling in a vacuum for 3 minutes.

The float was now brought into the water, the thermometer, supported in a stopper covered with tin foil, was placed in position, and the container was immersed in the thermostat to within a few cm. of its mouth, and left until it attained the bath temperature. Stirring was effected by gentle movements of the thermometer, and the position of the float in the still water was adjusted by the same means. The float was observed with a cathetometer telescope having a Leitz micrometer eye-piece graduated in 0.001 mm., the general arrangement of the apparatus being as shown in Fig. 5.

As Richards and Shipley had found (*loc. cit.*), a change of 0.001° at the flotation temperature sufficed to reverse the direction of motion of the float, but it is an extremely tedious matter to attain the exact temperature of flotation by a process of trial and error. We have found, however, that over a small temperature range, of the order of 0.1°, the velocity of the float (which is substantially constant at a given temperature) shows a strictly linear relationship with the departure from the true flotation temperature, and this has enabled us to reduce substantially the time required for an observation. The relationship is clearly shown by the typical set of

figures given in Table I, where, alongside the observed data (the temperature, T , and the time in seconds taken for the float to move through 1 mm.), are given the *difference* (ΔT) from the true flotation temperature (T_0) and the *velocity* for the float (in mm./10 sec.), which are plotted in Fig. 6.

TABLE I.
Effect of Temperature Differences on Velocity of Float.

Observed.		Calculated.		Observed.		Calculated.	
T .	Time of movement through 1 mm. (secs.).	ΔT .	Average velocity, mm./sec. $\times 10$.	T .	Time of movement through 1 mm. (secs.).	ΔT .	Average velocity, mm./sec. $\times 10$.
20.354°	15	+0.019°	0.67	20.335°	960	$\pm 0.000^\circ$	0.01
20.344	30	+0.009	0.33	20.332	100	-0.003	0.10
20.338	85	+0.003	0.12	20.326	33	-0.009	0.30
20.336	250	+0.001	0.04				

Evidently, since we are dealing with a particular float in the same substantially pure liquid, the true flotation temperature can be determined by observing the velocity of the float at any neighbouring temperature, and then adding algebraically the corresponding increment of temperature read from the graph. As an example of the method, the following observation is given :

At 20.330° the float *rises* 1 mm. in 100 sec.; therefore $V = 0.10$ mm./10 sec., whence, from the graph $\Delta T = 0.003^\circ$.

Since the float is rising, the observed temperature is *below* the true flotation temperature, which is, therefore, $20.330^\circ + 0.003^\circ = 20.333^\circ$.

In practice, for each flotation temperature at least three observations were made at different temperatures, each such that the velocity of the float did not exceed 1 mm. in 80 secs. It appears that the mean of the values so obtained should not differ from the true value by more than $\pm 0.0005^\circ$; therefore the limit of precision in the method is that of the temperature observation, represented by an error not exceeding $\pm 0.001^\circ$.

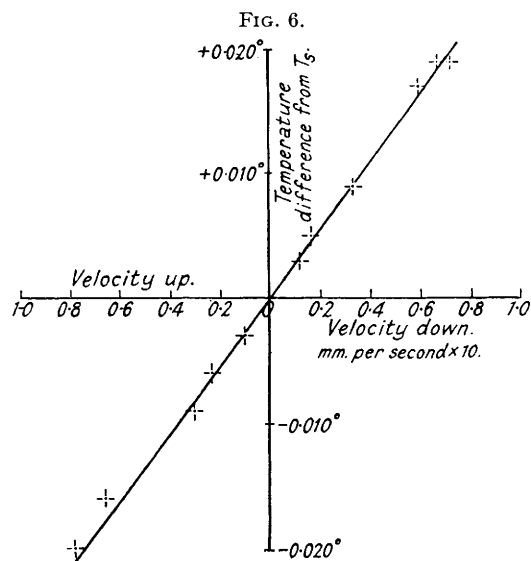

Actually, the error of the determination is rather less than this, since the result is the mean of three or more observations. The method of interpolation is extremely advantageous in that it enables a flotation temperature to be determined, by three observations, within an hour.

Certain features of the measurement are noteworthy. The "sticking" of the float recorded by previous workers (Richards and Harris, *loc. cit.*; Robinson and Smith, J., 1926, 1273) was again observed. This has usually been attributed to the electrical charging of the float, but it is difficult to see how in water, however pure, the charge can thus be localised. What is observed is an attraction of the float to the *wall* of the container and it is there, we believe, that the charge must reside. In any case, it was easy to overcome the effect by rolling the float gently round the wall of the tube by means of the thermometer.

Direct experiment showed that the flotation temperature was unaffected by pressures up to 0.5 atm., a conclusion confirmed by the fact that at a given temperature the rate of movement of the float was quite constant through 10 cm. depth of liquid. It follows that the compressibility of the float was the same as that of water, a result in agreement with the observation of Richards and Harris (*loc. cit.*) that whereas, with soft-glass floats, the flotation temperature changed by -0.00041° per mm. change of pressure, yet the corresponding change with floats of borosilicate glass ranged from $+0.00002^\circ$ to -0.00006° .

On the other hand, we are quite unable to account for the statement by the same authors

that dissolved air has no effect on the flotation temperatures. Numerous comparative measurements on conductivity water as it came from the still and again after removal of dissolved gas showed conclusively that out-gassing raised the flotation temperature by about 0.01° . As a further check on this point, a sample of water was examined (a) as it came from the still, (b) after out-gassing in a quartz vessel, and (c) after resaturation with gas by 20 minutes' passage of a stream of air freed from carbon dioxide. The observed flotation temperatures were (a) 20.314° , (b) 20.323° , (c) 20.314° . These very definite results agree with several earlier determinations by pyknetric methods (Marek, *Wied. Ann.*, 1891, **44**, 171; Chappuis, *Trav. Bur. Int.*, 1910, **14D**; Frivold, *Physikal. Z.*, 1923, **24**, 86).

In every case the measurement of flotation temperature was made at atmospheric pressure, immediately after out-gassing, the extent of re-solution of air in the liquid (which is perfectly still) being negligible during the period of measurement.

The figures for purified tap-water given in Table II are important because they serve to show the concordance of the determinations and also to prove the suitability of tap-water as a standard of density. The data relate to six samples of water, taken on the days specified, each sample being subjected independently to the stages of purification already described (p. 1208). The observed variations, therefore, include, not only the errors of the observations, but also errors arising from the purification process and any variations in the standard, and it seems clear that all these sources of error taken together do not affect the flotation temperature by more than $\pm 0.001^\circ$.

TABLE II.

Date, 1934.	Flotation temp., T_s .	Diff.	Date, 1934.	Flotation temp., T_s .	Diff.
Jan. 24	20.335°	nil	Feb. 8	20.335° (-)	nil (+)
" 31	20.335	nil	" 15	20.335	nil
Feb. 5	20.334 (+)	-0.001° (-)	" 19	20.336	+0.001°
				Means 20.335	0.000

The Standard Water.—The grounds for our rejection of conductivity water (p. 1207) are to be seen in the following random observations of T_s (made between Nov. 17th, 1933 and Jan. 31st, 1934) on conductivity water, prepared in the usual way by distillation in a counter-current of purified air using a copper still and a block-tin condenser: 20.321° , 20.323° , 20.323° , 20.322° , 20.302° , 20.311° , 20.302° , 20.305° , 20.302° , 20.321° , 20.330° , 20.329° , 20.329° . The density of this water was invariably *lower* than that of the original water from which it was prepared. Also, the magnitude of this density difference is much greater than would be anticipated from the degree of fractionation possible in the still. It appears that most of the density difference is attributable to the effect of the air-current, and that it may well be due in the main to a process of partial isotopic separation by *diffusion*.

The tap-water (see above), subjected to purification according to the scheme already described, had a flotation temperature of $20.335^\circ \pm 0.001^\circ$. The absolute density of water at this temperature according to the best available data (Thiessen, Scheel, and Diesselhorst, *Wiss. Abh. Phys.-Tech. Reichsanstalt*, 1900, **3**, 69; Chappuis, *Trav. Bur. Int.*, 1904, **13**) is 0.998160, but it will be observed that the error of this absolute value is at least five times the error of our comparisons.

Results.

In the tables which follow there are recorded for each sample, the serial number, the source, and the flotation temperature, T_s , together with the corresponding value, T_{H_2O} , for the standard water determined about the same time in order to obviate any error which might otherwise arise from changes in the float. The last two columns give, in each case, the value of $T_s - T_{H_2O}$, and the corresponding density difference between the sample and standard water expressed in γd . Appended to each table, where necessary, are notes giving further details of the sources of the samples.

Table III records the data for samples of natural water and mineral water of hydration. Water from a Sumatran spring has the same density as the English surface waters represented by the S. Wales spring water and London tap-water. Though the difference of the dew-pond waters from the standard is small, it may well be significant, since the low value for the Dorsetshire dew-pond is consistent with its being derived from condensation of atmospheric water vapour, and various accidents might conceivably account for the slight heaviness of the other sample.

Our results confirm the relative heaviness of Dead Sea water, already recorded by the

Bureau of Standards, which is almost certainly due to a concentration of the heavier isotopic water by low-temperature evaporation. The same cause probably accounts for the slight but definite increase of density in the water of Lake Pangong, where, although the evaporation is much less than in the salt lakes such as the Dead Sea or the Great Salt Lake of Utah, the efficiency of separation by evaporation would be greater owing to the lower temperature and pressure existing at an altitude of 13,500 ft.

If the Bureau of Standards' density for Dead Sea water be taken as identical with ours, their value for tap-water is also in agreement with ours; which may be taken as further evidence that surface waters generally are alike.

TABLE III.

Natural Waters and Water from Mineral Hydrated Salts.

No.	Origin.	T_s .	T_{H_2O} .	$T_s - T_{H_2O}$ $\times 10^3$.	$\Delta\gamma d$.
1	London water	20·335°	20·335°	0	0
2	South Wales, spring water	20·335	"	0	0
3	Dew-pond, Dorset	20·332	"	- 3	-0·63
4	Dew-pond, near Salisbury	20·337	"	+ 2	+0·42
5	Sumatra, spring water	20·335	"	0	0
6	Tibet, 13,500 ft.	20·342	"	+ 7	+1·47
7	Dead Sea	{ 20·345 20·347	{ 20·333 } 20·335 }	+ 12	+2·52
<i>Water of hydration of minerals.</i>					
8	Rasorite	20·365	20·335	+30	+6·30
9	Tincal	{ 20·347 20·349	"	+12 +14	+2·52 } +2·94 }
10	Carnallite	20·351	"	+16	+3·36

Notes on Origin of Samples.

- Spring water from Rosebush, Precelly, South Wales.
- and 4. By courtesy of Prof. H. B. Baker.
- From a spring of carbonated water on the east coast of Sumatra; by courtesy of Prof. F. Paneth.
- From Pangong Lake, Ladakh, Kashmir, altitude 13,500 ft., collected by Capt. C. E. C. Gregory, Royal Gharival Rifles; by courtesy of the Natural History Museum, South Kensington.
- Obtained by the courtesy of Sir John Cadman and the officials of the Anglo-Persian Oil Co., Ltd.
- and 9. Kindly supplied by Messrs. Borax Consolidated, Ltd., from their Californian deposits.
- Obtained from the Stassfurth deposits, by the courtesy of Prof. V. C. Illing, Royal School of Mines.

Because the hydrated minerals, Samples 8—11 inclusive, have probably been deposited during the evaporation of saline lakes, it is not surprising that their contained water should be heavy. The marked difference in this respect between rasorite ($Na_2B_4O_7 \cdot 4H_2O$) and tincal ($Na_2B_4O_7 \cdot 10H_2O$), occurring as they do in contiguous deposits, is curious. As the former has never been obtained artificially, nothing is known with certainty of its origin, but the marked heaviness of its water might possibly be accounted for were it produced by the slow dehydration of a primary decahydrate, and may, indeed, be held to afford some evidence for that mode of origin.

Table IV refers to a number of waters of vegetable origin, many of which show small increases in density. It is puzzling that the water of Cuban grape-fruit is light. On the other hand, a general survey of the positive values of $\Delta\gamma d$ suggests that they may be accounted for in the main by evaporation. The case of the tomato is particularly clear, since the plant is known to exhibit a large evaporation of water and the effect of this is more marked in Canary Islands tomatoes, grown in the open, than in English forced tomatoes grown under conditions tending to restrict evaporation.

Water from the combustion of sucrose (No. 17) is quite remarkably heavy, and this point merits further investigation. The sample was derived from both cane- and beet-sugar. Specimens of the two sugars (West Indian cane-sugar and Norfolk beet-sugar respectively) were burnt in oxygen and the resulting waters were condensed and purified. It was then found that the samples were rather small for purposes of measurement and so the two were united.

The water of the willow (*Salix caprea*) was investigated because it afforded a good means of comparing our results with those of the Bureau of Standards (Washburn and Smith, *Science*, 1934, **79**, 188), who had already investigated *Salix nigra*. As in their case, our "sap" water was obtained from the twigs by drying out at 150°, and the "wood" water by burning the dried

TABLE IV.
Waters of Vegetable Origin.

No.	Source.	T_s .	T_{H_2O} .	$T_s - T_{H_2O}$ $\times 10^3$.	$\Delta\gamma d$.
1	Orange, South Africa	20·328°	20·324°	+ 4°	+0·84
2	Coco-nut milk	{ 20·324	20·324	0	0
		{ 20·334	20·335	- 1	-0·2
3	Grape-fruit, Cuba	{ 20·321	20·324	- 3	-0·6
		{ 20·331	20·335	- 4	-0·8
4	Lemon, Italy	20·331	20·324	+ 7	+1·47
5	Melon, Rumania	20·326	20·327	- 1	-0·2
6	Pumpkin, Central U.S.A.	20·336	20·335	+ 1	+0·2
7	Marrow, England	20·340	20·335	+ 5	+1·05
8	Pineapple, Hawaii	20·349	20·335	+14	+2·94
9	„ South Africa	20·348	20·335	+13	+2·73
10	Pomegranate, Palestine	{ 20·341	20·335	+ 6	+1·26
		{ 20·339	20·335	+ 4	+0·84
11	Tomato, English (forced)	{ 20·347	20·335	+12	+2·52
		{ 20·349	20·335	+14	+2·94
		{ 20·356	20·335	+21	+4·41
12	„ Canary Islands	{ 20·353	20·335	+18	+3·78
13	Turnip, England	20·334	20·335	- 1	-0·2
14	Cabbage, England	{ 20·342	20·335	+ 7	+1·47
		{ 20·345	20·335	+10	+2·10
15	Onion, Holland	20·337	20·335	+ 2	+0·42
16	Rhubarb, England	20·335	20·335	0	0
17	Sucrose	20·376	20·335	+41	+8·61
18	<i>Salix caprea</i> , sap	{ 20·352	20·335	+17	+3·57
		{ 20·353	20·335	+18	+3·78
		{ 20·350	20·335	+15	+3·15
	„ wood	{ 20·350	20·335	+15	+3·15

twigs and condensing the products. The American results (sap + 2·8 γd ; wood + 5·4 γd) differ from ours only by amounts which may well be accounted for by the different species and habitat of their material.

The waters of animal origin (Table V) represent but a few random cases, and it is clear that they leave much room for further work. The two samples of ox-blood are probably representative, and so significance may attach to their being distinctly heavy. The sample of cow's milk, being drawn from a mixed supply, should also be representative. There is at present no evidence of a simple reason for its lightness. The samples of human milk and blood clearly cannot be regarded as representative, but they offer an invitation to further investigation inasmuch as they suggest that considerable variations may occur in the heaviness of the water in human fluids.

TABLE V.
Waters of Animal Origin.

No.	Index.	Description.	T_s .	T_{H_2O} .	$T_s - T_{H_2O}$ $\times 10^3$.	$\Delta\gamma d$.
1	U.1	Urine, human	{ 20·326°	20·327°	- 1	-0·2
			{ 20·327	20·327	0	0
2	AN.6	Milk, human	{ 20·346	20·335	+11	+2·31
			{ 20·346	20·335	+11	
3	AN.5	Blood, human	20·340	20·335	+ 5	+1·05
4	M.1	Milk, cow's	{ 20·331	20·335	- 4	-0·84
			{ 20·332	20·335	- 3	-0·63
5	AN.3	Blood, ox	{ 20·347	20·335	+12	+2·52
			{ 20·347	20·335	+12	
6	AN.4	„	20·344	20·335	+ 9	+1·89

Notes.—AN.6. Average sample from several persons, 2 or 3 days after parturition.

AN.5. From a female, age 50, suffering from polycythemia.

M.1. United Dairies Company's supply.

In many ways the data for industrial waters given in Table VI are the most interesting. It is well known that electrolytes contain the heavy isotope, roughly in proportion to the extent of electrolysis, and this is exemplified by Nos. 1, 2, and 5. The hydrogen generated from No. 2 was led to a gas-holder, where it deposited the slightly heavy moisture No. 3, and then was

compressed to about 20 atm., in large cylindrical reservoirs. Here it deposited a good deal of water (No. 4) which had been carried as vapour, and this water is markedly *light*.*

TABLE VI.
Waters from Industrial Sources.

No.	Index.	Origin.	T_s .	T_{H_2O} .	$T_s - T_{H_2O}$ $\times 10^3$.	$\Delta\gamma d$.
1	S.1	Caustic soda electrolyte	20·469°	20·324°	+145°	+30·4
2	H.1	" " "	20·422	20·327	+ 95	+19·9
3	H.3	From gas-holder trap, ex H.1	20·353	20·335	+ 18	+ 3·8
4	H.4	From compressed hydrogen, H.1	20·311	20·333	- 22	- 4·62
5	V.1	Chromium-plating bath	20·329	20·324	+ 5	+ 1·05
6	G.1	Separated water from oil: recovered benzol	20·321	20·324	- 3	- 0·6
7	G.2	Ditto: active-carbon recovered	20·311	20·324	- 13	- 2·73
8	G.3	Ditto: acid-refined benzol	20·334	20·335	- 1	- 0·2
9	G.4	Water from distillation of crude car- bolic acid	20·323	20·324	- 1	- 0·2
10	G.5	Water from carbolic finishing still	{ 20·303 20·311 }	{ 20·327 20·335 }	- 24	- 5·04
11	G.6	Glover-tower distillate	20·341	20·335	+ 6	+ 1·26
12	G.7	C.O.V. distillate	20·345	20·335	+ 10	+ 2·10
13	AP.1	Burnt fuller's earth from oil refinery	20·357	20·335	+ 22	+ 4·62

Samples 6 and 7 are waters obtained as the first runnings in the distillation of coal-tar benzols recovered by oil washing and by the active-carbon process respectively. In both cases the water is light, presumably because it has been carried as vapour in the gas prior to benzol recovery. It seems unlikely that the separation of light water has been effected by the process of preferential solution in benzol, since the first runnings from acid-refined benzol (No. 8) are practically normal water.

The very low value for Sample No. 9, from the first runnings of a crude carbolic distillation, is less easily accounted for, unless there be a preferential retention of heavy hydrogen in phenolic hydroxyl. This is not, perhaps, improbable, since Samples 11 and 12 afford evidence that the water held by sulphuric acid is distinctly heavy. This is shown even in the earliest stages of concentration in the Glover tower and is more marked in the further stage of concentration to C.O.V.

The last sample (No. 13) was obtained from the specified source by burning, condensation, and purification. The markedly high result probably indicates that liquid hydrocarbons rich in heavy hydrogen are preferentially adsorbed.

Table VII records the data for water from several concentration processes, and the manner in which the samples were obtained is indicated below.

With the kind co-operation of the Milford Haven Ice Co., Ltd., one of us (F. W. J.) secured samples representing ice first formed in the freezing of water and also the last fraction of water remaining unfrozen. The freezing tanks were of about 120 kg. capacity and were filled with ordinary supply water (MH.1). They were cooled in a brine-bath kept at about -5° , freezing took about 24 hours, and each block of ice then contained a core of about 500 c.c. of water still unfrozen, an average sample being taken from about 50 blocks (MH.2). The blocks are released from the tanks by a brief immersion in hot water, and since the ice so melted is evidently that first formed, an average sample of the resulting water was taken (MH.3). The results show that the ice first formed is distinctly heavy, and the water last to freeze correspondingly light. In confirmation of the former observations about the lightness of water carried as vapour, we find that the hoar frost condensed on the colder parts of the plant (MH.4) is also light.

The isotopic separation in water by freezing disclosed by these results throws light on an old mystery, the marked difference in density between natural and artificial ice, illustrated by the data in Table VIII. It is evident, as was first pointed out by Nichols (*Physical Rev.*, 1899, 8,

* In connexion with these samples we acknowledge our indebtedness to Mr. E. Cone, of the Southern Oil Co., Ltd., Trafford Park, Manchester; to Mr. E. Knowles, of the International Electrolytic Co., Ltd., who has given us much help and advice in connexion with the characteristics of his cells, which are very generally used for the production of electrolytic hydrogen and oxygen; to Messrs. W. G. Adam, H. Hollings, and F. M. Potter, of the Gas Light and Coke Co., for the interesting samples (Index G); and to several others too numerous to mention.

TABLE VII.
 Waters Resulting from Concentration Processes.

No.	Index.	Description.	T_s .	T_{H_2O} .	$T_s - T_{H_2O}$ $\times 10^3$.	$\Delta\gamma_d$.
<i>Refrigeration plant.</i>						
1	MH.1	Original water	20·335°	20·335°	0°	—
2	MH.2	Residual water	20·322	"	- 13	- 2·73
3	MH.3	Ice first formed	20·340	"	+ 5	+ 1·05
4	MH.4	Hoar frost	20·321	"	- 14	- 2·94
<i>Large-scale crystallisation of alum.</i>						
5	X.1	Original water	20·327	20·335	- 8	- 1·68
6	X.2	First-crop crystals	20·342	"	+ 7	+ 1·47
7	X.3	Fourth mother-liquor	20·339	"	+ 4	+ 0·84
8	X.4	Fourth-crop crystals	20·340	"	+ 6	+ 1·26
<i>Laboratory crystallisation of sodium sulphate.</i>						
9	J.1.	Water used	20·400	20·335	+ 65	+13·4
10	J.2	Crystal water	20·400	"	+ 65	+13·4
11	J.3	Mother-liquor	20·400	"	+ 65	+13·4
<i>Adsorption : silica gel.</i>						
12	Ad.1	Water adsorbed : 24 hours	20·330	20·328	+ 2	+ 0·4
13	Ad.2b	" " 8 weeks	20·338	20·336	+ 2	+ 0·4
14	Ad.2a	Supernatant water	20·334	"	- 2	- 0·4
<i>Adsorption : charcoal.</i>						
15	Ad.3b	Water adsorbed : 8 weeks	20·337	20·336	+ 1	+ 0·2
16	Ad.3a	Supernatant water	20·332	"	- 4	- 0·8
<i>Distillation : 48-in. vacuum column.</i>						
17		Original water	20·400	20·336	+ 64	+13·4
18		Head fraction	20·400	"	+ 64	+13·4
19		Tail fraction	20·462	"	+126	+26·5
<i>Distillation : 25-ft. column.</i>						
20		Original water	20·335	20·335	0	0
21		Tail fraction	20·367	"	+ 32	+ 6·7
<i>Thermophilic cotton fermentation.</i>						
22	E.1	Residual water	20·337	20·335	+ 2	+ 0·4
23	E.2	Cotton-press extract	20·335	"	0	0

 TABLE VIII.
 Density of Ice.

Ref.	Method of experiment.	Kind of ice.	Density.	
			Natural.	Artificial.
1	Weighing in liquid	Natural	0·9179	
2	Dilatometric	Artificial		0·91567
3	Flotation in $CHCl_3$ -petroleum	"		0·9177
4	Dilatometric	"		0·91674
5	"	"		0·91619
	Weighing in liquid	"		0·91603
		Natural (icicles)	0·91795	
		" (new pond ice)	0·91792	
		" (pond ice 1 year old)	0·91623	
		" (new pond ice)	0·91760	
		" (new and old)	0·91661	
6	Volume by displacement	"		
6	Weighing in water	"		
7	Direct weighing of buoyancy in mercury	Artificial		0·9160
			Means 0·9174	0·9165

- Brunner, *Pogg. Ann.*, 1845, **64**, 116.
- Plücker and Geissler, *ibid.*, 1852, **86**, 265.
- Dufour, *Compt. rend.*, 1862, **34**, 1080.
- Bunsen, *Pogg. Ann.*, 1870, **141**, 1.
- Nichols, *loc. cit.*
- Barnes, *Physikal. Z.*, 1901, **3**, 81; Barnes and Cooke, *Trans. Roy. Soc. Canada*, 1902, **8** (iii), 143.
- Vincent, *Proc. Roy. Soc.*, 1902, **69**, 422.

21), that this difference (about 1 part in 900) is much greater than any conceivable experimental error in the density determinations, and must be real. Hitherto, it has been quite unaccountable.

Now it is apparent that the samples of natural ice giving high results (0.9179—0.9176) had been formed in every case by the selective freezing of a small fraction of the total mass of water, and must, therefore, have contained a relatively high proportion of "heavy" ice. Though pure "heavy" ice is believed to be lighter than ordinary ice, it is not unlikely that the presence of a *small* proportion of the heavier isotopic water may actually increase the density of ice. The samples of artificial ice, on the other hand, have been obtained by freezing the whole or the greater part of the mass of water under investigation, and give what is to be regarded, presumably, as the true value for ice from ordinary water. It is notable that the few samples of *old* natural ice examined have a lower density (0.91623 for pond ice a year old, and 0.91661 as an average value for samples of St. Lawrence River ice kept in storage for various periods up to 3 years). The reason for this is still obscure.

For the specimens X.1—X.4 we are indebted to Messrs. Peter Spence & Sons, Ltd., and particularly to Mr. H. Spence and Mr. I. P. Lewellyn, who very kindly undertook for us the following experiment.

Potash alum was dried in a vacuum stove as far as possible without decomposition of the salt: it then contained about 80% of anhydrous alum and 20% of water; 338 lbs. of this alum were dissolved in 320 lbs. of water (X.1) and crystallised. A considerable loss of water by evaporation occurred. The alum crystals were rejected, and the mother-liquor, weighing 100 lbs., was saturated hot with 85 lbs. of fresh dried alum. This yielded on crystallisation 144 lbs. of drained crystals and 30½ lbs. of mother-liquor, 10½ lbs. of water being lost by evaporation. The mother-liquor was again saturated, using 26 lbs. of dried alum, and on cooling yielded 42½ lbs. of drained crystals and 11½ lbs. of mother-liquor, 2½ lbs. of water being lost. In the fourth and last crystallisation carried through in the works laboratory under conditions preventing evaporation, 13¼ lbs. of dried alum were used to saturate the mother-liquor, and the product was 3¼ lbs. of mother-liquor (X.3) and 22½ lbs. of drained alum crystals (X.4). The loss of 1 lb. in the total weight is attributable to the rinsing of the crystals with 250 c.c. of distilled water. The original water (X.1), being condensed steam, was light, while that contained as water of crystallisation in the first crop of crystals (X.2) was heavy by about 1.5*gd.* In this crystallisation, however, a good deal of evaporation occurred, and it is probable that this is responsible for the whole of the increase in the proportion of heavy water. In the second and third crystallisations evaporation was minimised, while in the fourth it was prevented entirely. The result for the water of crystallisation in the last crop of crystals (X.4) is about what would be anticipated if slight evaporation had served to balance the addition of a small amount of light water (as residual water in the dried alum), and the results as a whole may, in our opinion, be taken to indicate that the crystallisation of alum does not affect the isotopic ratio in the water used. The point seemed of sufficient interest to warrant a check experiment, and several pounds of anhydrous sodium sulphate were therefore crystallised in the laboratory from a quantity of electrolytic water containing about 0.05% of heavy water, in such a way that about half the water was removed as water of crystallisation. In this experiment no evaporation was permitted, and on examining the water of the crystals (J.2) and of the mother-liquor (J.3) it was found that they were identical with each other and with the original water (J.1).

As selective adsorption and desorption are phenomena of wide occurrence, it seemed to be of interest to investigate the adsorption of water. Silica gel and charcoal were chosen as adsorbents; the former because of its great affinity for water, the latter because of its general use as an adsorbent. In the first experiment, silica gel (3 lbs.) was kept in contact with water for 24 hours; then it was superficially dried and the adsorbed water was recovered by heating to 150° in a vacuum. This process was then repeated with the same sample of silica and a fresh sample of water, and the desorbed product from both operations was subjected to a second selective adsorption on the same silica gel. The adsorbed water finally recovered (Ad.1) is slightly, but distinctly, heavier than the original water. A second experiment was made by allowing silica gel (3 lbs.) to stand in water (15 l.) for eight weeks, and then heating the silica, superficially dried, to 200° at atmospheric pressure. The adsorbed water thus recovered (Ad.2*b*) is slightly heavy, and the supernatant water (Ad.2*a*) correspondingly light.

A similar procedure was adopted with charcoal (2 lbs.) and water (17 l.) and the adsorbed (Ad.3*b*) and the supernatant (Ad.3*a*) water showed a similar change in density. It is interesting to note that in this case the density change of the supernatant water is four times that of the desorbed water, the volumes of these being 17,000 and 900 c.c. respectively. Apparently, a considerable proportion of the heavy water in the original specimen must have been retained by the charcoal in the form of the small quantity irreversibly adsorbed or recoverable only with much difficulty. These results are in general agreement with those of Washburn and Smith

(*J. Chem. Physics*, 1933, 1, 426), who found a concentration of heavy water by charcoal after 3 weeks' immersion.*

In the first distillation experiment the vacuum-jacketed column, 4 feet in effective length, was packed with glass rings, 4 mm. \times 4 mm., and the distillation was conducted under a pressure of about 20 mm. Starting with 3 l. of electrolytic water, about + 13 γ d heavy, it was found that the tail fraction of about 300 c.c. was markedly heavier (+ 26 γ d) and probably contained twice as much heavy water as the original material. For the second experiment, a 25-foot column was used. It was built up from 5-ft. lengths of 2-cm. diameter Pyrex tubing, each packed with beads and joined to its neighbours by rubber tubing, and the whole was lagged with a 1" thickness of cotton wool. Tap water (2.6 l.) was distilled through the column under about 30 mm. pressure at the rate of about 400 c.c. per hour, and the tail fraction of about 200 c.c. was purified and examined. Its density shows that, under these conditions also, distillation effects a considerable concentration of the heavier isotopic water.†

The last results in Table VII relate to an experiment made in order to see whether any separation of water is effected by bacterial action. A preparation of pure cotton "linters" ‡ in water, with suitable amounts of calcium phosphate and inorganic nitrogen, was inoculated with thermophilic bacteria which were allowed to grow actively for about 3 weeks. The methane, hydrogen, and carbon dioxide formed were allowed to escape through a reflux condenser, by which most of the evaporated water was returned. Some 4 lbs. of cotton and about 10 l. of water were consumed. The residual liquid and the water held on and in the cotton both gave, after purification, nearly normal density values, indicating that the bacterial action had had no appreciable effect on the isotopic ratio of the water. The slight change in density of the residual free water may well be accounted for by the selective effect of the evaporative loss of water in the evolved gas.

Part of the cost of the apparatus used in this work was defrayed by means of a grant from Messrs. Imperial Chemical Industries, Ltd., whom we thank for this assistance.

IMPERIAL COLLEGE OF SCIENCE AND TECHNOLOGY,
SOUTH KENSINGTON, S.W. 7.

[Received, June 12th, 1934.]
