

111. An Electrical Sorption Balance and Calorimeter.

By S. J. GREGG.

This apparatus enables the differential heat of adsorption to be determined simultaneously with measurements of the adsorption itself provided the pressure of the gas is greater than about 1 mm. of mercury. Its performance has been tested by measurements of the differential heat of adsorption of water vapour on "active alumina": the results agree satisfactorily with those calculated from the adsorption isotherms by means of the Clausius-Clapeyron equation, and from heat-of-wetting measurements. For the adsorption range 0.10–0.20 g. of water vapour per g. of alumina, the differential heat of adsorption lies within 5% of the latent heat of condensation.

THE usefulness of the sorption balance technique would be considerably enhanced if the heat of adsorption could be measured at the same time as the adsorption itself. By incorporating a thermometric device into the sorption balance described in the foregoing paper, it has been found possible to measure the temperature rise brought about by adsorption; since the amount of adsorption causing this heat evolution is also measured, by the sorption balance, the differential heat of adsorption can be calculated once the heat capacity of the adsorbent and its container, and also the magnitude of the cooling losses, are known.

EXPERIMENTAL.

To adapt the sorption balance in this way, the adsorbent container is made of copper or silver foil (approx. 0.1 mm. thick) bent into a cylinder of approx. 12 mm. diameter and 40 mm. length, and soldered down the seam. Co-axial

FIG. 1.

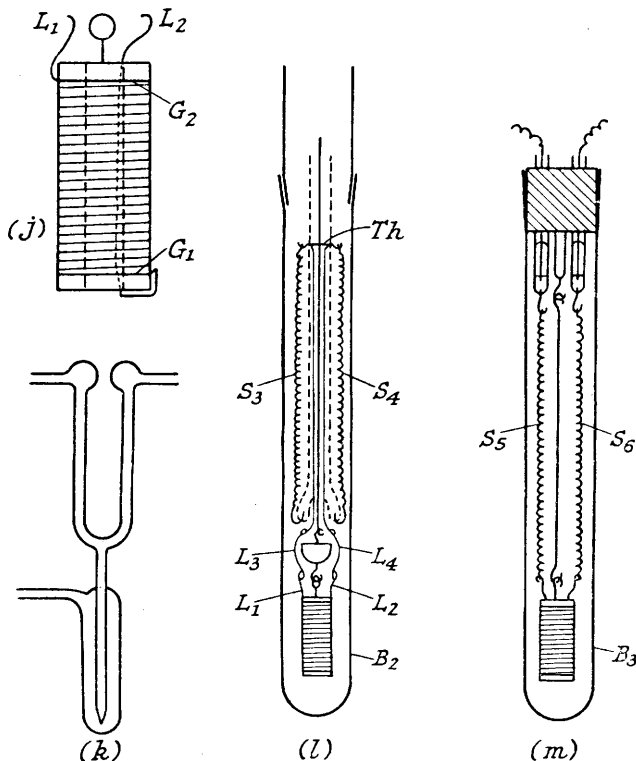

with it is a cylinder of copper or silver gauze small enough in mesh to retain the particles of adsorbent, of the same length but about 6 mm. in diameter. The two cylinders are fastened together by soldering to a ring of foil, serving as the bottom of the container. The space between the two cylinders is destined to receive the adsorbent, the inner cylinder of gauze facilitating the access of gas to the adsorbent [Fig. 1(j)]. The outer cylinder is wrapped in a piece of mica cleaved as thinly as possible, the mica being fastened top and bottom by binding with rings of copper or silver wire soldered in position. The resistance thermometer wire is then wound round the outside of the mica cylinder commencing by soldering it on to one ring [G_1 , say, of Fig. 1(j)] and winding the turns as closely as possible without touching, finishing off at G_2 where it is again fastened by soldering. The wire should be of material with a high temperature coefficient of resistance: 40 S.W.G. nickel or platinum is suitable.

The container A , when charged with a known weight of adsorbent, is hung from the right-hand arm of the balance (see Fig. 1 of previous paper), the counterpoise C being adjusted in weight as described in the previous paper. The balance, together with the connecting tubes and manometers, storage reservoir for the adsorbate vapour, etc., must be surrounded by an air thermostat kept constant to within $\frac{1}{2}^{\circ}$. The electrical leads L_1 and L_2 from the container are soldered on to the bottom of leads L_3 and L_4 , and the outer tube B_2 placed in position. The external leads connected

to L_3 and L_4 are then taken off to one arm of a Callendar-Griffiths bridge (*Phil. Trans.*, 1891, **182 A**, 43, 119) or a suitable modification thereof. Another container as similar as possible to A but with a winding of some 10% lower resistance, and having springs S_5 and S_6 exactly similar to S_3 and S_4 for connecting the winding to the exterior, is set up in tube B_3 [Fig. 1(m)]. This arrangement serves as the compensation resistance and is connected into the "compensation" arm of the bridge. In operation, B_3 is placed alongside the working tube B_2 in the thermostat.

The resistance thermometer is calibrated for temperature by leaving B_2 and B_3 in the same thermostat at temperature T_1 (say 20°) for an hour or so to come into thermal equilibrium, and taking the bridge reading—say z_1 ohms. B_2 is then transferred to a thermostat at T_2 (say 40°) and the new resistance (say z_2) read off after another hour or so. The calibration figure is then $(z_2 - z_1)/(T_2 - T_1)$ ohms per degree.

To carry out an experiment, the adsorbent is first out-gassed by pumping through V (see Fig. 1 of foregoing paper) and the tube T_2 is then surrounded by a water thermostat at the desired temperature. After about an hour the first admission of gas is made. This is best done by means of a mercury valve [Fig. 1(k)] which can be operated by a two-way tap on the control table so that readings on the bridge and on the sorption balance scale can commence immediately afterwards. Readings of both θ and Δw are taken at frequent intervals so as to permit the plotting of accurate curves of θ versus time, and of Δw versus time, or better versus log time (Δw g. = increment in weight adsorbed after the particular admission of gas; θ = increase in temperature above the commencing temperature).

The response of the resistance thermometer is very rapid, as reference to Fig. 2, which gives the θ - t curve for an admission of water vapour to active alumina, will show (full line). This rapid response arises both because most of the adsorbent is in contact with the metal of the conductor, and also because the adsorbent, though a bad conductor, is at nearly the same temperature throughout since the process of adsorption (particularly with a granular adsorbent) occurs almost uniformly throughout the adsorbent. Actually, there must be a small temperature gradient from the middle of the adsorbent layer to its sides because the material of the calorimeter container does not participate in the adsorption and so must receive its heat only from the adsorbent.

Calculation of the Differential Heat of Adsorption, ΔH .— θ is first corrected for loss of heat to the surroundings by an application of Newton's law of cooling in the ordinary manner. (The system has been found to obey

FIG. 2.

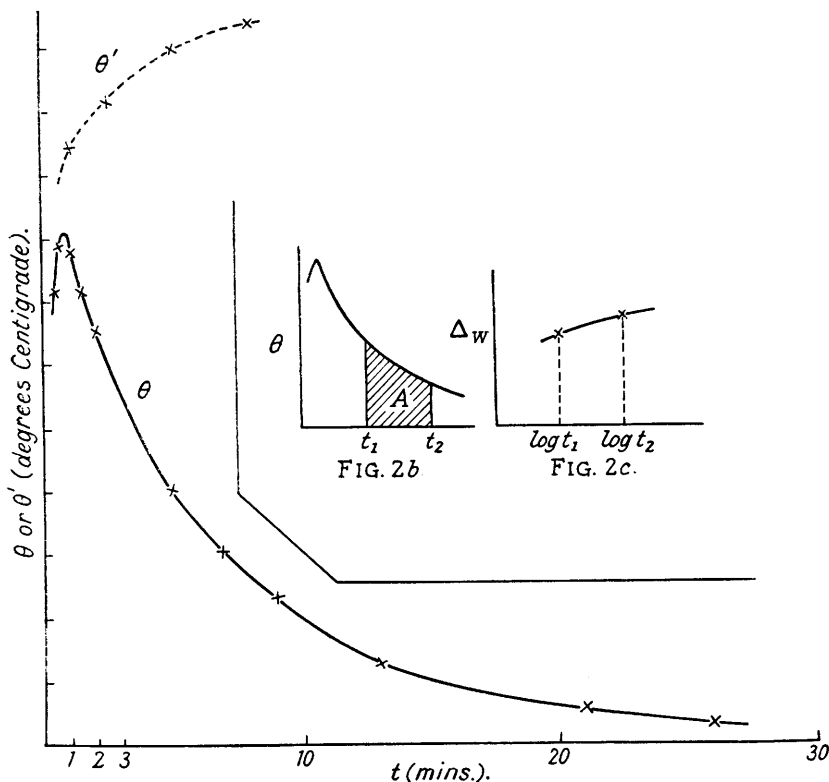

this law with reasonable accuracy.) The time axis is divided into short intervals of the order 1—2 minutes; the total area under the curve up to any time t , when multiplied by the Newton constant k (determined as described later), gives the loss of temperature due to cooling effects; adding to the ordinate at t , one obtains θ' , the corrected temperature. A typical θ' curve is shown in Fig. 2 (broken line) together with its corresponding θ curve (full line).

The differential heat of adsorption is then given by

$$\Delta H = \frac{\theta' \text{ at time } t}{\Delta w \text{ at time } t} \times C \times M \text{ cal. per mole of adsorbate,}$$

where M is the molecular weight of the adsorbate and C calories is the thermal capacity of the container and

contents. It is clear that a number of values of ΔH can be obtained from each θ - t curve, depending on the number of time intervals chosen.

Determination of the Cooling Constant k and the Thermal Capacity C.—The amount of heat lost to the surroundings per second is a function of the size, shape, and material of the surface of the cooling body, the conductivity of the surrounding gas, and the temperature difference θ , but not of the mass of the body. This amount of heat is given by $C \cdot d\theta/dt = Ck\theta$, *i.e.*, Ck calcs. per second for unit temperature difference. The product Ck should therefore be a constant for a given container under given conditions, independently of the individual values of C ; Ck will, of course, depend on the thermal conductivity of the gas, and so will vary from gas to gas. The determination of Ck , described below, must accordingly be carried out separately for each gas used in the calorimeter. Ck is independent of the pressure of the gas, however, provided this is in excess of the figure for which thermal conductivity begins to depend on pressure, *i.e.*, about 1 mm. of mercury in the present experiments.

To determine Ck , the winding of the resistance thermometer (Th) is used as a heating coil; Th is disconnected from the bridge by means of a two-way switch and a known current passed through it for about 2 hours till thermal equilibrium is reached; the pressure of the gas must be above the critical figure referred to above. At a given moment, the switch is turned over so as to disconnect Th from the heating current and connect it to the bridge. Readings of θ are taken at frequent intervals. Except for the first few seconds, these readings closely obey Newton's law: by plotting $\log \theta$ against time a good straight line is obtained. Extrapolating back to the moment when the heating current was switched off gives a temperature θ'' . We then have:

$$\text{Loss of heat to the surroundings per sec.} = Ck\theta''$$

$$\text{Net gain of heat from the current per sec.} = (I^2 - I_0^2)\omega/J$$

where I is the heating current, I_0 the current passing through Th when connected to the bridge, ω the resistance of Th , and J the mechanical equivalent of heat. Consequently

$$Ck = (I^2 - I_0^2)\omega/J\theta = P \text{ (say)}$$

so that Ck can be obtained. The corresponding value of k can be obtained as $2.3 \times$ slope of the curve of $\log_{10}\theta$ versus time; C is then given as $C = P/k$. This method for C has been checked by experiments with a substance of known specific heat—calcite—in the container. The mean of the results (1.32 calcs.) agreed satisfactorily with the value (1.28 calcs.) calculated from the known thermal capacity of the container and the specific heat and mass of the calcite (capacity of container by ice calorimeter = 0.485 cal.; capacity of 4.11 g. of calcite = 0.795).

C is, of course, a function of the amount adsorbed, so that, assuming the specific heat of the adsorbed material is constant—say c —the heat capacity C for any given total adsorption w grams is $C = C_0 + wc$, where C_0 is the heat capacity of the container plus the out-gassed adsorbent. An estimate of c can be obtained by carrying through a determination of Ck , and thus of C , on the adsorbent charged with several different contents of adsorbate. This has been done for water vapour on alumina, and the specific heat c of the adsorbed water found to be 1.10 ± 0.15 , in moderate agreement with Porter and Swain's figure of 0.93 for the specific heat of water adsorbed on sugar charcoal (*J. Amer. Chem. Soc.*, 1933, 55, 2792). The margin of error is considerable, but it should be noted that the total heat capacity of the water rarely amounts to 25% of the total heat capacity C , so that even an error of $\pm 15\%$ in c leads at the worst to an error of $\pm 4\%$ in C . Actually, the figure $c = 1.0$ was used in the subsequent calculations.

Determination of the Cooling Constant k.—The value of k corresponding to any given adsorption can be calculated from the relation $k = P/C = P/(C_0 + wc)$. It can also be obtained "internally" from the θ - t and the Δw - $\log t$ curve for any given admission of gas, as follows: select two times t_1 and t_2 where the adsorption has become nearly constant so that the θ - t curve is nearly of Newton form. The actual cooling is then the Newton cooling effect less the heating effect of the additional adsorption ($w_2 - w_1$). Then

Heat loss between t_1 and t_2 due to Newton cooling

$$= Ck \times \text{Area under the curve between } t_1 \text{ and } t_2 = CkA, \text{ say (see Fig. 2b).}$$

Heat gained by adsorption between t_1 and $t_2 = (w_2 - w_1)\Delta H/M$ (cf. Fig. 2c)

Thus

$$\text{Net heat lost between } t_1 \text{ and } t_2 = CkA - (w_2 - w_1)\Delta H/M$$

so that fall of temperature between t_1 and t_2

$$= \theta_2 - \theta_1 = \frac{CkA - (w_2 - w_1)\Delta H/M}{C}$$

$$\text{i.e.,} \quad k = \frac{\theta_2 - \theta_1}{A} + \frac{(w_2 - w_1)\Delta H/M}{CA}$$

All quantities on the right-hand side of this last equation can be obtained from the two curves except ΔH and C . Since these appear in the second term, which is small compared with the first, approximate values may be used for them. A check on these k values is to see whether the product Ck (C being calculated by equation $C = C_0 + wc$) gives a constant independent of w . In practice the deviation of Ck from constancy is

sometimes considerable—up to 15%—so it is best to calculate k as P/C and use the “internal” method as a general check.

Failure of the Calorimeter at Low Pressures.—The variation of k with pressure in the low-pressure range, already referred to, is great enough to render the calorimeter unreliable at pressures below about 1 mm. of mercury. It is convenient to note that the Pirani gauge, since it is based on the pressure-dependence of thermal conductivity, begins to function at approximately the pressure where the calorimeter begins to fail. In addition, the breakdown is signalled by the fact that the equilibrium reading on the Callendar–Griffiths bridge (*i.e.*, the reading when adsorption has become constant so that the bridge current heating effect is just balanced against cooling losses) is no longer constant but depends upon the pressure.

Application to Desorption.—The procedure so far described for the heating effect accompanying adsorption, is equally applicable to the cooling effect of desorption.

Illustrative Results from the System Alumina–Water.—The measurements here recorded are restricted to the pressure range 0.1–0.7 of the saturated vapour pressure of water at 25° and 35°, and the adsorption range 0.05–0.18 g. of water vapour per g. of alumina. The alumina was out-gassed for one hour at 110°.

In Fig. 3, values of the differential heat of adsorption ΔH are plotted against the adsorption. It will be seen that the values of ΔH fluctuate somewhat irregularly around a value of 10,300 cal. per mole, with a maximum deviation of some ± 1000 cal. and an average deviation of about ± 400 cal. ΔH appears to fall slightly with increasing adsorption. The fluctuations are no doubt largely due to experimental error (particularly in assessing the cooling effect) but may perhaps also be attributed in part to the fact that the adsorption is not carried out under strictly reversible conditions so that a proportion of the “external work” RT ($= ca.$ 600 cal. per mole) fails to register as heat in the calorimeter. This proportion would vary from measurement to measurement and might perhaps account for 100 or so cal. per mole out of the total fluctuation.

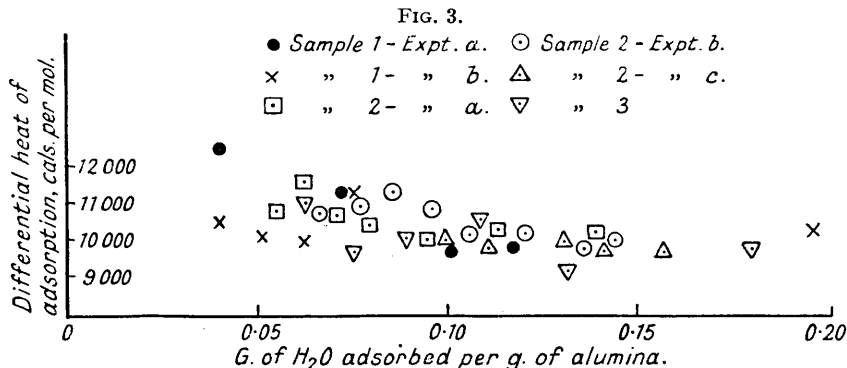

These directly determined values of ΔH may be compared with the indirect value obtained by two different methods, (i) application of the Clausius–Clapeyron equation to isotherms at neighbouring temperatures; (ii) determination of the heating of wetting in liquid water of alumina samples charged to different contents of water vapour.

Method (i). Using the sorption balance, desorption isotherms were measured at 18°, 25°, and 35° respectively (desorption isotherms are known to approximate more closely to equilibrium values than adsorption isotherms); the alumina was out-gassed as already described, exposed at 25° to nearly saturated water vapour, then desorbed in steps. When the adsorption had fallen below the range under investigation, the thermostat was changed to 35°, the alumina again charged with nearly saturated water vapour, and the desorption curve mapped out at this temperature. The procedure was then repeated at 18°.

The differential (“isosteric”) heat of adsorption at any given adsorption w is then given by the integrated form of the Clausius–Clapeyron equation:

$$\Delta H = 2.303 RT_1 T_2 (\log_{10} p_2 - \log_{10} p_1) / (T_2 - T_1) \text{ cal. per mole of adsorbate.}$$

Strictly, the equation is only applicable if the adsorption is reversible with respect to temperature: on raising the temperature, *e.g.*, from 25° and 35°, under constant volume conditions, a point on the 35° isotherm should be obtained; by cooling to 25° one should return to the starting point. On trying a few such temperature jumps on the present system, this exact return was not always achieved, showing the system to be incompletely reversible with respect to temperature. The lack of reversibility is related to the hysteresis loops which were found in the adsorption isotherms in some other experiments not recorded here. Consequently, the ΔH values given below cannot be regarded as more than approximate—an inference emphasised by the imperfect agreement amongst the values themselves:

Isotherms.	G. H ₂ O per g. of alumina.	ΔH , cal. per mole of H ₂ O.	Isotherms.	G. H ₂ O per g. of alumina.	ΔH , cal. per mole of H ₂ O.
25° and 35°	0.165	10,100	18° and 25°	0.170	11,000
	0.140	10,500		0.145	11,300
	0.120	12,100		0.120	11,700

For the most part, these values are rather higher than those from the electrical sorption calorimeter; the discrepancy is no greater, however, than that usually found between calorimetric and isosteric values of the heat of adsorption (cf. Brunauer, "Physical Adsorption of Gases and Vapours," 1943, 223—225); it is probably to be accounted for partly by the RT term and partly by the lack of reversibility.

Method (ii). A number of weighed samples of the alumina were placed in bulbs and fused on to an attachment whereby they could be evacuated simultaneously. After an hour's out-gassing at 110° , the adsorbent was exposed to saturated water vapour in the absence of air. After some hours (adsorption equilibration is very slow near the saturated vapour pressure) the attachment was weighed, one bulb sealed off, and the attachment reweighed; next, some water vapour was pumped out, the weighing and sealing-off was repeated, and so on for all the bulbs. By simple arithmetic, the weight of water adsorbed in each bulb can be calculated. The heat of wetting of the contents of each bulb was then determined by breaking it under water in a thaw-melt calorimeter at 19.0° (acetophenone as the calorimeter working substance). By plotting the heat of wetting per g. of alumina against the weight of water vapour adsorbed per g. of alumina, an approximately straight line is obtained the slope of which, by application of Hess's law, can be shown equal to the "net heat of adsorption," viz., $(\Delta H - L)$, where L is the latent heat of condensation of water at 19° (cf. Lamb and Coolidge, *J. Amer. Chem. Soc.*, 1920, **42**, 1146). Successive experiments with three or four bulbs in each experiment gave the following results for $(\Delta H - L)$: 250, 100, 300, 380, 500 cal. per mole of water vapour. The differences, which exceed the error of measurement, are probably due to the lack of adsorption equilibrium in the vapour-charged samples—the same kind of error as that discussed under method (i). Since L is 10,530 cal. per mole (International Critical Tables, **5**, 148) this gives for ΔH at 19° values ranging from 10,630 to 11,030 cal. per mole. These are somewhat higher than the results from the sorption calorimeter, but having regard to the uncertainty as to the RT term in the latter and as to equilibration in the former, the agreement between the two methods can be regarded as satisfactory.

Thus, the results from methods (i) and (ii) may be considered as evidence for the satisfactory performance of the electrical sorption calorimeter. Summarising the results from all three methods, one may say that under reversible conditions, the differential heat of adsorption ΔH of water vapour on alumina lies within 5% of the latent heat of condensation for the pressure range 0.1—0.7 of the saturated vapour pressure, and the approximate adsorption range 0.10—0.20 g. of water per g. of alumina; ΔH is nearly independent of the amount adsorbed, over this range.

The calorimeter should be suitable for measuring isothermal heats of reaction of gases with solids, isothermal heats of decomposition of solids, etc.

The author thanks Mr. K. Sing, B.Sc., for carrying out most of the heat-of-wetting measurements, and Prof. F. H. Newman for the loan of a Callendar-Griffiths bridge. The sample of active alumina was kindly provided by Messrs. Peter Spence and Co.