

230. *A Thermochemical Evaluation of the Bond Strengths in Some Carbon Compounds. Part I. (Methyl Carbon)-Iodine and (Methyl Carbon)-Magnesium.*

By H. MACKLE and A. R. UBBELOHDE.

Thermochemical schemes for the evaluation of the bond strengths of carbon-iodine in organic iodides and of carbon-magnesium in Grignard compounds have been devised and tested. The heats of the reactions involved have been determined where necessary in a specially constructed calorimeter. From these data it is calculated that the heat of dissociation $D(\text{CH}_3\text{-I}) = 54.7 \pm 1.4$ kcal. The agreement with the value (54 kcal.) obtained from kinetic data substantiates a mechanism previously proposed for pyrolysis of methyl iodide.

A rather less accurate value is estimated from the experimental data for $D(\text{CH}_3\text{-Mg}) = 67.0$ kcal.

In testing the thermochemical schemes used, the conditions governing the relative extents of the competing reactions in ethereal solution, *viz.*, $\text{CH}_3\text{MgI} + \text{I}_2 \longrightarrow \text{CH}_3\text{I} + \text{MgI}_2$ and $2\text{CH}_3\text{MgI} + \text{I}_2 \longrightarrow \text{C}_2\text{H}_6 + 2\text{MgI}_2$, have been investigated experimentally with special reference to the possible role of the equilibrium $2\text{CH}_3\text{MgI} \rightleftharpoons \text{Mg}(\text{CH}_3)_2 + \text{MgI}_2$. The concurrent attack of free methyl radicals on the ether has also been examined.

ACCURATE values of the heats of dissociation of various chemical bonds are still very limited in number. Particularly for organic compounds, the great body of information on chemical reactivity completely swamps the information on chemical bond strength. When reactivity can be expressed in terms of quantitative kinetics, the activation energies obtained (Rice and Johnson, *J. Amer. Chem. Soc.*, 1934, **56**, 214; Butler and Polanyi, *Trans. Faraday Soc.*, 1943, **39**, 19) may throw some light on the chemical binding in the ground states of the molecules participating in the reaction. But in general, organic chemistry is the chemistry of activated states of molecules. Theories relating bond structure with chemical and thermodynamic behaviour can only be tested properly by quantitative data on the ground states. Accurate data of this kind are particularly important for assessing departures from the additivity rule for bond energies arising because of resonance, steric factors, etc.

Within recent years, valuable advances have been made in the more accurate evaluation of bond strengths of organic compounds, for example in homologous series, by combustion calorimetry (Rossini, *Bull. Bur. Stand. J. Res.*, 1934, **13**, 29, 189; 1939, **22**, 115). Differences in the heats of formation of related hydrocarbons have also been determined from hydrogenation reactions (Kistiakowsky, *J. Amer. Chem. Soc.*, 1936, **58**, 137; 1937, **59**, 831; *J. Chem. Physics*, 1942, **10**, 305). But in the case of the more reactive or labile organic compounds where bond strengths are of particular interest, combustion calorimetry may be handicapped by technical difficulties.

The present paper describes a method of obviating combustion calorimetry by using some of the reactions of Grignard reagents for the purposes of evaluating heats of reaction, and hence of obtaining bond energies in certain covalent organic compounds. The scope of the experiments

was limited in the first instance to the evaluation of carbon-halogen bonds, though the methods have obvious possibilities of extension in view of the wide range of organometallic compounds now known (Gilman, "Advanced Treatise on Organic Chemistry", Wiley, 1943). The data obtained can also be used to evaluate, rather less accurately, the carbon-magnesium bond strength in the Grignard compound used.

The selection of the best experimental conditions involves two main problems: (a) selection and control of the chemical reactions whose heat values are to be evaluated; (b) selection of the calorimetric techniques.

Preliminary experiments, and records in the literature, made it clear that the problem of controlling Grignard reactions so as to give consistent and useful heat data might involve many difficulties. On the other hand, fairly simple calorimetric techniques were found to give reliable heat data, at any rate to the accuracy with which chemical control could be achieved. A brief discussion of the chemical reactions may serve to illustrate the kind of difficulties encountered.

Each of the chemical reactions used must be amenable to accurate quantitative evaluation, and must preferably proceed to completion. Any competing reactions must be susceptible to accurate evaluation and control.

The most obvious reaction to select for thermochemical investigation is the direct formation of the Grignard reagent from metallic magnesium and methyl iodide:



In fact, preliminary experiments showed that this reaction was not very convenient. Difficulties encountered included the variable induction period, which interferes with the timing required for calorimetric corrections. Again, side reactions such as the Wurtz reaction

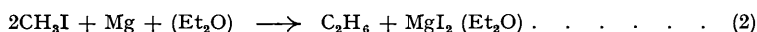

and possibly also attack of the solvent by free methyl radicals (see below)



led to the loss of methyl iodide in processes competing with (1). The amount of these side reactions could be determined, *e.g.*, by analysing the gases formed, but the experimental evaluations were awkward in assessing the thermochemical corrections. Furthermore, the formation of the Grignard compound does not necessarily proceed to completion whether excess of magnesium or of methyl iodide is used, and this again may involve undesirably large correction terms.

Again, equation (1) calls for the use of very pure methyl iodide, free from iodine, water and other impurities, if reliable thermochemical data are to be obtained. The purification of this substance to the requisite very high degree is not very convenient when a large number of experiments have to be carried out.

The possibility was next investigated of starting with the Grignard compound pre-formed in the calorimeter, and of measuring the heat evolved on decomposing this compound in various ways. Decomposition by water, added either pure or in ethereal solution, involves the reaction

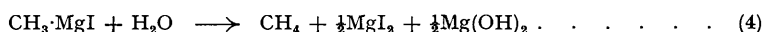

Calorimetrically, this reaction is not very suitable, owing to the fact that magnesium hydroxide (or hydroxyiodide) has a variable and rather large lattice energy. A further complication is that the volume of gas evolved is rather large and calls for special experimental treatment.

Investigation showed that decomposition of methylmagnesium iodide by iodine in ethereal solution involved the reactions

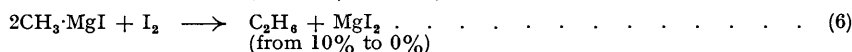
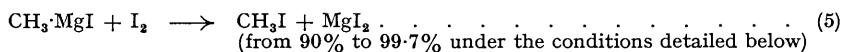

together with attack of the solvent by methyl

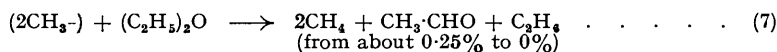

It was originally planned to use reaction (5) together with the reaction



to evaluate the carbon-iodine bond strength from known dissociation energies. However, it

was found that the course of (5) and (6) could be controlled with such precision that it was possible to evaluate the individual heats of reaction

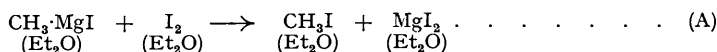

and

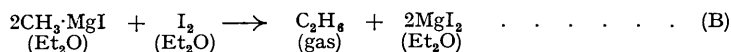

without having recourse to reaction (8). Precision of reproducibility was verified both from measurements of the heats evolved, and by means of detailed analysis of the reaction products. The principal factors involved in the control of reactions (5) and (6) are the overall concentration, the concentration of magnesium iodide, and the temperature.

From (A) and (B) it could be calculated, as discussed in detail below, that

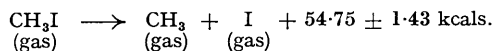

and

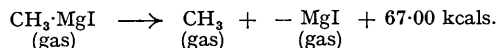

It may be added that the scheme of reactions (5)—(8) would appear to offer further advantages over, say, (3) and (4) in extending the present methods to other Grignard compounds. The difficulties in initiating the formation of Grignard compounds in some cases is well known, and this seriously handicaps the use of (3) for thermochemical work, whereas once the compounds have been formed (5) and (6) usually proceed smoothly.

Calorimetric Techniques.—The calorimeter was deliberately kept simple (see below) in order to facilitate investigation and control of the competing chemical reactions. In essence, the reactions used involved the mixing of ethereal solutions of the Grignard compound with ethereal solutions of iodine. In order to facilitate the carrying out of a large number of determinations, a special mixing pipette was used, described below.

The temperature rise resulting on mixing, measured in arbitrary units of galvanometer deflection, was matched as accurately as possible by adjusting a measured input of electrical energy so as to give as nearly as possible the same temperature rise and rate of temperature rise under the same conditions (cf. Rossini, *Chem. Reviews*, 1936, 18, 235; Eucken, "Handbuch der experimental Physik", VIII, Teil 1, pp. 48 *et seq.*).

EXPERIMENTAL.

Preparation of the Solution of Grignard Compound.—Fig. 1 shows the apparatus used; *A* is a "Pyrex" vessel of about 100 c.c. capacity; the upper end of the condenser was protected from moisture and carbon dioxide by layers of calcium chloride and soda-lime, and normally a slow stream of dry oxygen-free nitrogen flowed through it.

Specially pure dry crystalline magnesium (Fe, 0.0004; Zn, 0.003; Pb, 0.002; Si, Ni, Sn, Cd, 0.005%), obtained by courtesy of Magnesium Metal Corporation, was broken into small pieces in a warm mortar and dried in a vacuum oven at 60° before use. About 2 g. were inserted, and covered with pure ether. The required amount of redistilled methyl iodide was then added, and the solution refluxed till analysis in test experiments showed that the reaction would proceed no further (about 30 mins.). Traces of magnesium hydroxide in the solution were allowed to settle, a small flow of pure, dry, oxygen-free nitrogen being maintained to prevent back diffusion of moisture. Amounts of this clear solution were siphoned over as required by replacing the stopper *B* by a stopper *C*, and closing the vent tube *E* with a finger. Before closing this vent, the receiving vessel *D* was swept out with dry, oxygen-free nitrogen. A small counter current of this nitrogen was maintained throughout as shown, to prevent back diffusion of moisture. This completely obviated the loss of any reagent by hydrolysis. 10-C.c. portions of the reagent could be pipetted from *D* either into the calorimeter (previously swept out with nitrogen) or into water for analysis, in each case the tip of pipette being protected continuously by nitrogen and the mouthpiece fitted with a calcium chloride-soda-lime tube.

Pure dry nitrogen was prepared by passing cylinder nitrogen over copper gauze washed with ammonia (d 0.880) to remove oxygen, and then washing the gas with concentrated sulphuric acid, potassium hydroxide pellets, and a phosphoric oxide tube to remove the last traces of water vapour. All joints were sealed with a beeswax-rosin mixture (1 : 1).

Preparation of Pure Dry Ether.—Great care was exercised in the preparation of the ethyl ether, since possible catalytic effects from impurities might affect the relative importance of competing reactions in the calorimeter. The steps described below were modified where convenient from previously published methods. Portions of 1000 c.c. of commercial ether were shaken with the following: (1) ten times with 50-c.c. portions of distilled water; (2) once with a solution containing 4.5 parts of saturated potassium hydrogen carbonate solution and 1 part of saturated mercuric chloride solution (Poleck and Thummel, *Ber.*, 1889, 22, 2863) (after this stage the ether should not give the iodoform test for alcohols); (3) strongly alkaline potassium permanganate solution in 50-c.c. portions till no further reduction occurred (to remove aldehydes); (4) a concentrated ferrous sulphate solution to remove any remaining peroxides; (5) finally, with more water. The ether was then allowed to stand overnight with calcium chloride, and was bottled

in Winchester quart bottles with sodium wire for at least a week, before distillation. (6) A 2-l. still was filled from time to time with ether treated as above, (1)—(5). The distillation was carried out in an atmosphere of oxygen-free nitrogen. The ether vapour was allowed to pass over sodium hydroxide pellets (Hammond, U.S.P. 1923, 1466435), thence by way of a condenser into a receiver, from which it could be pipetted off as required by using a counter current of dry, oxygen-free nitrogen during any transfer. All pipettes were protected at the mouthpiece with a tap and a soda-lime tube.

The improvement in purity of the ether, compared with ether merely dried over sodium wire, was verified by the substantial shortening of the induction period in preparing methyl- and ethyl-magnesium iodides and by a somewhat increased yield (Mackle, in the press).

Ether thus prepared was a rather costly solvent (final yield 25% of initial quantity) and the residues after calorimetry, etc., which had never been exposed to oxygen, were fractionally distilled again to recover the pure ether. Induction period measurements (Mackle, *loc. cit.*) verified that no loss of purity had occurred during the reactions involved.

Calorimetry.—After some preliminary designs had been tested, the final design of calorimeter used was as shown in Fig. 2. It consists essentially of a copper vessel (A) with paraffin (b. p. 120—150°) as

FIG. 1.

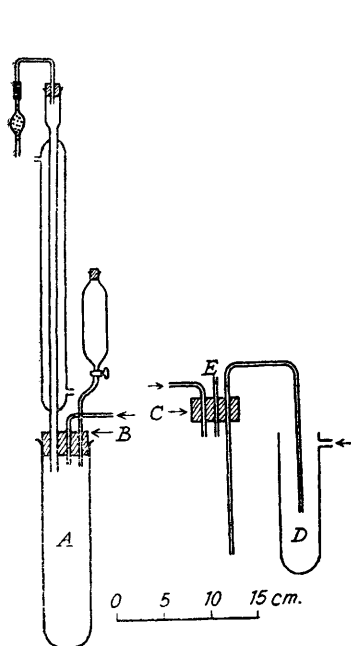
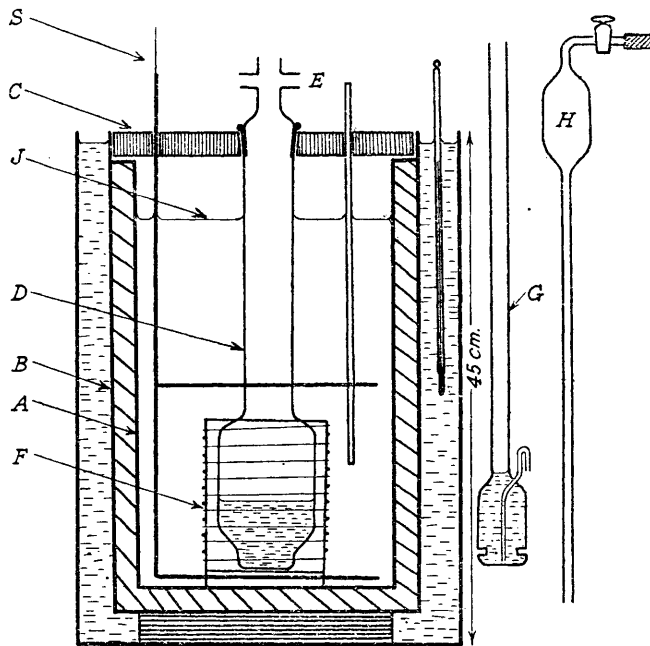

FIG. 2.



calorimeter fluid. (The paraffin oil level is shown at J.) This vessel is insulated from a water-bath "environment" whose temperature is adjustable to be as nearly as possible the same as that of the calorimeter. Thermal insulation is obtained by means of a layer $\frac{3}{4}$ " thick of *magnesia alba levis* carefully dried and sealed from the air, and contained in an outer metal jacket (B). A lid of perspex (C) is coated on the under side with aluminium foil, to minimise heat exchange by radiation. The reciprocating mechanical stirrer S is fitted with vanes (not shown). The lower part of the stirrer is made of copper, and the part projecting from the calorimeter of glass tubing, to minimise heat transfer.

Temperature changes of the calorimeter fluid were measured by means of a 5-junction copper-constantan thermocouple with a galvanometer and lamp and scale ($0.02^\circ = 1$ mm. approx.). The temperature scale was calibrated against a standard N.P.L. thermometer, in order to obtain the approximate temperature of reaction, though estimates of heats of reaction do not depend on this calibration (see below).

An electric heating coil was constructed by winding bare "Ferry" nickel-chrome wire of negligible temperature coefficient, non-inductively on a "Pyrex" frame. This frame fits closely over the reaction vessel as indicated by F so as to facilitate "matching" the heat input into the calorimeter by the chemical and electrical processes.

The resistance (66.588 ± 0.020 ohms) of the heating coil was measured from time to time by means of a Carey-Foster arrangement. When the current through this coil was switched on, it was measured at intervals by determining the potential drop across a calibrated resistance of about 2 ohms.

The chemical reaction vessel is indicated by D. It consists of a "Pyrex" bulb, plated with copper on the outside up to the level of the frame of the heating coil, and fitted with a long neck. A small continuous flow of oxygen-free dry nitrogen is maintained in the upper part, at the joint (E), throughout the experiments, to prevent back diffusion of moisture. Normally the reaction vessel contains the solution of Grignard reagent. Special tests verified that the loss of ether vapour under these conditions was negligible.

A special reaction pipette *G* (shown separately in Fig. 2) rests on the bottom of this reaction vessel; the pipette is closed at the top by means of an easy-fitting rubber sleeve (not shown). It is refilled *in situ* as required up to a calibration mark (*e.g.*, with a solution of iodine in ether, approx. 150 g./l.) whilst it is withdrawn up to the neck of the reaction vessel. For this filling, the long thin pipette *H* is used. Careful checks showed that the delivery of fluid from the reaction pipette could be reproduced to $\pm 0.25\%$.

In determining the heat evolved in a chemical reaction, the calorimeter was first allowed to come to approximate equilibrium, with the reaction vessel and pipette both filled. Temperature-time observations were then recorded, and at a convenient moment the contents of the pipette were discharged into the reaction vessel, by applying a measured pressure of nitrogen for the requisite interval of time, previously tested in blank experiments.

The contents of the reaction vessel were then gently stirred by raising and lowering the pipette several times through a few cm., so as to utilise the groove at the bottom, and the temperature-time observations were continued till a steady state was again well established.

From the temperature-time plot, the usual corrections were applied (*cf.* Roth, described in Eucken, *op. cit.*). The temperature of the external water-bath was adjusted so that the correction did not exceed 5% of the actual change in temperature due to chemical reaction, in the least favourable case, and 3.5% on the average. Furthermore, the calorimeter was calibrated from time to time by means of the electrical heating coil, with a heat input whose magnitude and duration were adjusted so as to give very nearly the same temperature-time curve as that obtained for the chemical reaction. Thus the change in thermo-e.m.f. reading due to the heat of reaction (corrected for any heat exchange) was equated directly to the electrical energy required to give a similar change in thermo-e.m.f., without depending, except in a subsidiary degree, upon the actual temperature scale used, or the precision with which the corrections for heat exchange with the surroundings could be calculated. Fig. 3 illustrates a typical temperature-time curve, from which the "true rise" was obtained by the standard procedure. Using convenient arbitrary units, the corrected mean rise for ten experiments with 100% reaction (5) was 70 ± 1 units, and for ten experiments with conditions chosen to give 90% reaction (5) and 10% reaction (6) the mean rise was 79 ± 1 units.

Electrical calibration under exactly the same conditions, with Grignard reagent in the reaction vessel and pure dry ether in the delivery pipette, gave as the mean of ten experiments with closely matched preliminary and post-heating curves 152.2 ± 0.2 cal. $\equiv 78 \pm 1$ units.

Control of the Competing Reactions.—The major difficulty in carrying out the calorimetry of Grignard reactions was to ensure reproducibility of the extent to which the competing reactions (5)–(7) took place within the calorimeter. Special investigations were carried out to examine the influence of the more important variables on the yield of various products, as follows:

(i) For analysing the amount of methylmagnesium iodide present in the solution at any stage, the acid-alkali titration due to Gilman (*J. Amer. Chem. Soc.*, 1923, **45**, 150) was followed. Phenolphthalein was used as indicator. For one or two special experiments, the amount of methylmagnesium iodide in solution was evaluated from the volume of methane obtainable, following a method originally due to Zerewitinoff and studied in detail by Gilman (*ibid.*).

(ii) The amount of iodine in the solution delivered by the special reaction pipette was determined by test deliveries into excess of standard 0.1*N*-sodium thiosulphate. These were reproducible to $\pm 0.25\%$. Originally, iodine in hexane was used, as it was thought that this would be less susceptible to concentration changes due to loss of solvent, than iodine in ether. But with experience there was no difficulty in delivering reproducible quantities of iodine in ether, which are preferable on account of the higher concentrations, and because their use avoids changing the composition of the solvent obtained as a result of mixing.

(iii) When a solution of iodine in ether is added to the Grignard reagent, the extent to which the competing reactions take place depends somewhat on the temperature, the rate of mixing, and the concentration of the Grignard reagent.

The temperature of the solutions in the reaction vessel had to be kept at about 15° throughout the experiments, to avoid possible difficulties from vapour-pressure variations of the ether, so that this variable did not in fact alter in the present experiments. Theoretical considerations suggest that a substantial change in temperature might alter the relative importance of the reactions. For example, a substantial rise in temperature might increase the attack on the solvent ether by the free radicals formed (see below), by analogy with the photochemical observations of Norrish and Bamford (*J.*, 1938, 1544).

Experiments were carried out on the rate of mixing, since the relative extent of reactions (5) and (6) [*cf.* Fig. 4(a)] might be quite sensitive to such a factor. For instance, the fastest interaction between iodine and the Grignard reagent might occur in two steps:

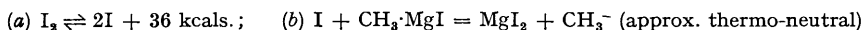

At the momentary boundary between a solution with excess of iodine and a solution with excess of methylmagnesium iodide the methyl radicals formed by the reaction $\text{CH}_3\text{MgI} + \text{I} \longrightarrow \text{MgI}_2 + \text{CH}_3^-$ have a momentary free existence before they either (a) combine with further iodine atoms or molecules to form methyl iodide, $\text{CH}_3 + \text{I}_2 \longrightarrow \text{CH}_3\text{I} + \text{I}$, or (b) combine with neighbouring hydrocarbon groups.

FIG. 3.

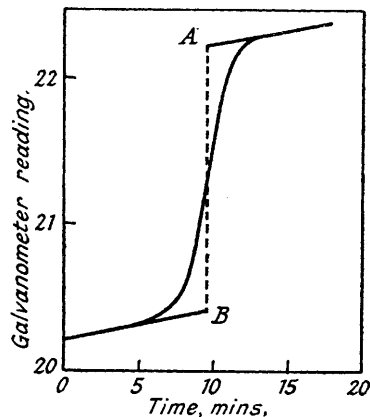

These might be other methyl radicals, which could form ethane or disproportionate [cf. reaction (6)], or to a limited extent the ethyl groups in the ether might be attacked [cf. reaction (7)].

On this supposition vigorous mixing would promote reaction (5) by ensuring that the methyl radicals have every chance to collide with iodine, whereas slow addition and a high concentration of Grignard reagent would promote reaction (6) by favouring further collisions with methyl or ethyl.

Experiments in varying the rate of addition from the reaction pipette were carried out in the reaction vessel. The extent to which the competing reactions occurred was determined by analysis of the ratio of methyl iodide formed to the iodine added.

20 C.c. of the solution of methylmagnesium iodide, prepared as described above, were pipetted into the reaction vessel. The concentration of this iodide was determined separately on three samples of 10 c.c. each, by Gilman's method. A known amount of iodine, insufficient to complete the reactions (5) and (6), was added by means of the delivery pipette. The methylmagnesium iodide not used was then estimated as before. If only reactions (5) and (6) take place, the extent to which each occurs can be calculated from the iodine used, and the methylmagnesium iodide used, by simple proportion.

As a check on this calculation, the amount of methyl iodide formed in the reaction vessel was estimated, after hydrolysing the contents, by warming to 45° and bubbling oxygen-free nitrogen through it, and passing the vapours into alcoholic silver nitrate solution. From the weight of silver iodide precipitated, the weight of methyl iodide formed was calculated. Blank experiments carried out on the original solution of methylmagnesium iodide before adding iodine showed that no methyl iodide was present at the start.

These experiments distinguish between iodine used to form methyl iodide, as in (5), and iodine used to liberate hydrocarbon, by reactions (6) and (7). The further evaluation of the extent of (7) is discussed below.

A typical experiment was as follows: 2 G. of pure distilled magnesium, 50 c.c. of purified ether, and 5.0 c.c. of methyl iodide were used to prepare the solution of methylmagnesium iodide. Titration of the

FIG. 4.

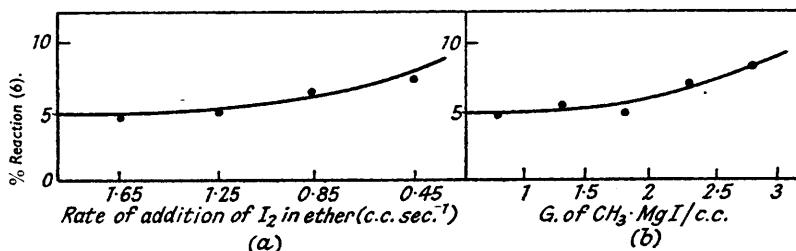

original solution gave 1.738 ± 0.002 g. of methylmagnesium iodide per 20 c.c. Two successive additions of iodine solution were made from the delivery pipette *A* (total, 1.526 g. of iodine). Titration showed that the resulting solution contained 0.682 g. of Grignard reagent in 20 c.c., *i.e.*, the iodine used 1.056 g. of methylmagnesium iodide. But 1.526 g. of iodine would use 1.000 g. of methylmagnesium iodide if all decomposed according to reaction (5), and 2.000 g. if all decomposed according to reaction (6) or (7). Hence, in this case 94.5% of reaction (5) and 5.5% of reaction (6) or (7) had occurred.

In this particular experiment, the recovery of methyl iodide in the check determination, from the weight of silver iodide collected, corresponded with 94.0% of reaction (5). Similar checks were carried out a number of times to verify the assumptions made above.

Results plotted in Fig. 4(a) made it easy to select a rate of addition such that the course of the reaction was substantially independent of small accidental variations in the rate of mixing, and reproducible calorimetry could thus be ensured.

Finally, the concentrations of the various components before mixing might be expected to influence the relative extent of the competing reactions, for similar reasons to those discussed with reference to the rate of addition.

Fig. 4(b) gives the result of experiments to explore the effect of this variable. These were carried out under the same conditions as were used for calorimetry, except that no temperature-time curves were plotted. It will be noted that, even at the lowest concentration of methylmagnesium iodide used, reaction (6) occurred to the extent of 5%.

A useful discovery facilitated the obtaining of reactions particularly suitable for the calculations of bond strengths. If the views of Schlenk and Schlenk (*Ber.*, 1931, **64**, 734; cf. Noller, *Ber.*, 1929, **62**, 920; Evans, *J. Amer. Chem. Soc.*, 1934, **56**, 654) are accepted, then it should be possible to displace the equilibrium $2R \cdot MgI \rightleftharpoons MgR_2 + MgI_2$ to the left by adding excess of magnesium iodide. From the literature, the equilibrium constants appear to be of the order unity in most cases. It seemed highly likely that the reaction $MgR_2 + I_2 \rightarrow MgI_2 + (2R)$ would lead to less formation of RI, and more formation of R_2 and disproportionation, than *e.g.*, $R \cdot MgI + I \rightarrow MgI_2 + R$. This possibility was tested by adding 1 g. of anhydrous magnesium iodide for every 20 c.c. of the clear solution of Grignard reagent in the reaction vessels, before pipetting over the iodine. It was found that this completely suppressed the reaction (6) in favour of reaction (5). Consequently, by carrying out a series of calorimetric determinations first with methylmagnesium iodide as prepared directly and then with excess of magnesium iodide present, it was possible to obtain the heats of reaction for the processes

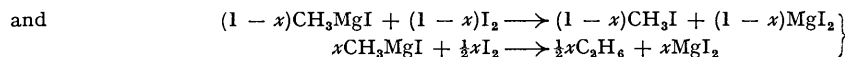
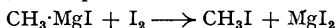

where x was determined by accurate analysis after the heat evolution was completed, and ranged between 10% and 0%. By this means, the values

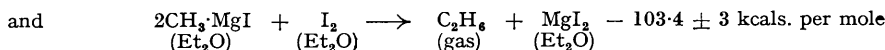
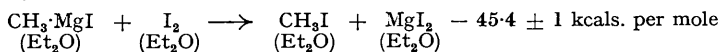

could be evaluated. The acquisitive convention is used for signs, *i.e.*, heat evolved is accounted lost by the system and is given a negative sign.

In describing the above experiments, no mention has yet been made of the allowance for the possibility of reaction (7) competing with reaction (6). Attack of solvent ether by free methyl radicals is known to occur under certain conditions (*Ann. Reports*, 1944, **41**, 184). The products include methane, ethane, ethylene, and acetaldehyde, as can be represented by rewriting reactions (6) and (7) as follows, starting with two methyl radicals in each case :

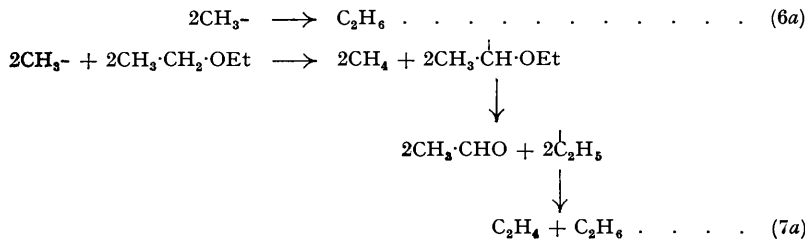

Hence, if (7a) occurs to any extent, at the expense of (6a) it will lead to a substantially greater volume of gas, which will include ethylene.

To obtain experimental evidence on this point, a series of determinations were carried out on the gas evolved on adding a solution of iodine in ether to ethereal methylmagnesium iodide. In a typical case, 4 c.c. of iodine-ether added to excess of methylmagnesium iodide gave 6.2 c.c. of gas (corrected for the partial pressure of ether vapour) at 15°. Under these conditions, the extent of reaction (5) was known to be 90.2%. If all the remaining iodine was used according to reaction (6), 5.7 c.c. of ethane would be produced at 15°. The somewhat larger volume obtained implies that reaction (7) occurs to the extent of not more than 2.5% of the allowance originally made for reaction (6), *i.e.*, to not more than 0.25% of the overall process.

As a cross-check, the amount of ethylene in the gases was determined by gas-analysis using absorption by bromine water. The volume of ethylene in the 6.2 c.c. was 0.16 c.c., which again implies that under these conditions solvent attack occurs to the extent of not more than 0.25% of the overall process. The very small correction this involves in the evaluation of the calorimetric data is discussed below.

DISCUSSION.

Using the experimental values for heats of reaction in ethereal solution, it is necessary to evaluate the heats of reaction for the same reactions carried out in the gas phase, in order to compute the bond energies.

If we formulate the cyclic process

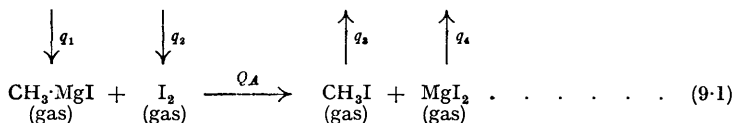
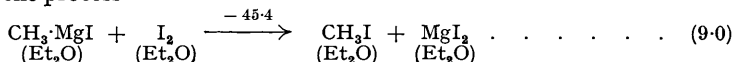

where q_1, q_2, q_3, q_4 are the increases in heat content for the processes of solution, in the sense indicated, then

$$-45.4 = (q_1 + q_2 + q_3 + q_4 + Q_A) \dots \dots \dots (9.2)$$

Similarly for the cyclic process

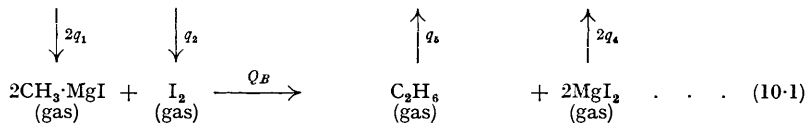
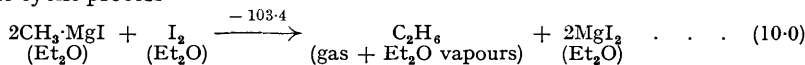

$$-103.4 = (2q_1 + q_2 + 2q_4 + q_5) + Q_B \dots \dots \dots (10.2)$$

The term q_5 is inserted owing to the fact that in the calorimetric evaluation as carried out above the gas evolved is saturated with ether vapour. It is evaluated as below, from the heat of condensation of ether; *i.e.*,

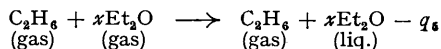

In separating the thermochemical components of equation (9·1) we may begin by writing, for the break-up of CH_3MgI and MgI_2 into radicals and atoms :

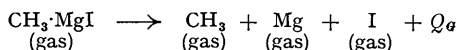

and

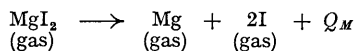

Equation (9·1) is equivalent to

$$Q_G + D(\text{I-I}) - D(\text{CH}_3\text{-I}) - Q_M = Q_A \quad \dots \quad (9\cdot3)$$

By applying the same procedure to equation (10·1) we can write

$$2Q_G + D(\text{I-I}) - D(\text{CH}_3\text{-CH}_3) - 2Q_M = Q_B \quad \dots \quad (10\cdot3)$$

i.e.

$$\frac{1}{2}Q_B = Q_G - Q_M + \frac{1}{2}D(\text{I-I}) - \frac{1}{2}D(\text{CH}_3\text{-CH}_3) \quad \dots \quad (10\cdot4)$$

Subtracting (10·4) from (9·3), we have

$$Q_A - \frac{1}{2}Q_B = \frac{1}{2}D(\text{I-I}) + \frac{1}{2}D(\text{CH}_3\text{-CH}_3) - D(\text{CH}_3\text{-I}) \quad \dots \quad (11)$$

or, inserting the experimental values from (9·2) and (10·2) and rearranging :

$$\begin{aligned} D(\text{CH}_3\text{-I}) &= \frac{1}{2}D(\text{I-I}) + \frac{1}{2}D(\text{CH}_3\text{-CH}_3) + (\frac{1}{2}Q_B - Q_A) \\ &= \frac{1}{2}D(\text{I-I}) + \frac{1}{2}D(\text{CH}_3\text{-CH}_3) - 6\cdot3 \pm 1 \\ &\quad + (\frac{1}{2}q_2 + q_3 - \frac{1}{2}q_5) \quad \dots \quad (12) \end{aligned}$$

It will be clear that with this particular combination of thermochemical terms, many of the corrections cancel or combine in such a way as to minimise the errors. Furthermore, inspection of equation (19) (below) shows that the net contribution from the present experimental data is small in the scheme utilised, so that the influence of the larger errors is minimised. The terms in equation (12) are evaluated as follows :

$$\frac{1}{2}D(\text{I-I}) = 18\cdot20 \pm 0\cdot03 \text{ kcal.} \quad \dots \quad (13)$$

(Brown, *Physical Rev.*, 1931, **38**, 709).

$$\frac{1}{2}D(\text{CH}_3\text{-CH}_3) = 42\cdot15 \pm 1\cdot1 \quad \dots \quad (14)$$

(Rossini, *Bull. Bur. Stand. J. Res.*, 1934, **13**, 28, 189; Kistiakowsky, *J. Chem. Physics*, 1942, **10**, 305; Skinner, *Nature*, 1946, **158**, 592; U.S. Dept. of Commerce, *Nat. Bur. Stand.*, 1947, "Tables of selected values of thermodynamic properties", Series III, Table 8).

q_2 and q_3 refer to the summation processes for which heat data are known (Bichowsky and Rossini, "Thermochemistry of Chemical Substances", Reinhold, 1936; and direct experiments on mixing methyl iodide and ether in the present calorimeter) :

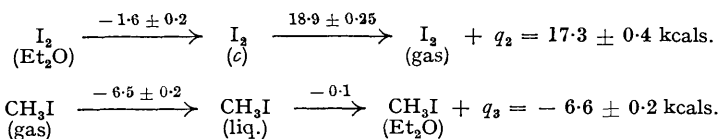

q_5 arises, as explained, because in the direct calorimetric experiment the gases are saturated with ether vapour. The actual proportion present was determined by absorption with sulphuric acid (monohydrate) in gas-analysis experiments. It was found that on the average at 15° 4·1 c.c. of gaseous product consisted of 1·2 c.c. of ether vapour and 2·9 c.c. of permanent gases, *i.e.*, the volume of ether vapour entrained in the reaction

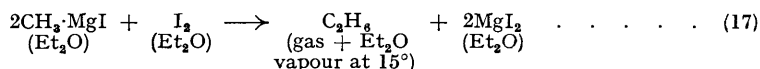

is 1·2/2·9 = 0·38 mole per mole of ethane.

The molar heat of vapourisation of ether at 15° is 6·5 kcal. (Int. Crit. Tables).
 The probable error is estimated as about 3%, *i.e.*,

$$q_5 = +2.7 \pm 0.1 \text{ kcal.} \quad \dots \dots \dots (18)$$

Inserting these values, we have

$$\begin{aligned} D(\text{CH}_3\text{-I}) &= 18.2 \pm 0.3 \\ &+ 42.2 \pm 1.1 \\ &- 6.3 \pm 1.0 \\ &+ 8.6 \pm 0.2 \\ &- 6.6 \pm 0.2 \\ &- 1.35 \pm 0.05 \\ \hline &= 54.75 \pm 1.4 \text{ kcal./mole} \quad \dots \dots \dots (19) \end{aligned}$$

In the above, the probable errors in the data taken from published values are as shown. The overall probable error in the calorimetric data now obtained is taken as $\sqrt{a^2 + b^2}$ where $a = \pm \sqrt{\Delta^2/n(n-1)}$ for reaction (5) and b is the corresponding value for one half mole of reaction (6).

It can be readily verified that the contribution due to reaction (7) can be neglected, provided the methylmagnesium iodide consumed in reactions (6) and (7) be counted as being all consumed by reaction (6). For this purpose, self-consistent bond data may be taken from Sidgwick ("The Covalent Link in Chemistry", 1933). Suppose two free methyl groups combine as in reaction (6). The heat contribution is

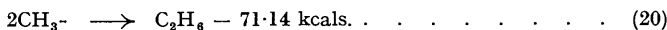

If, on the other hand, the two methyl groups attack the solvent ether, at the hydrogen atom α to oxygen, the successive making or breaking of bonds

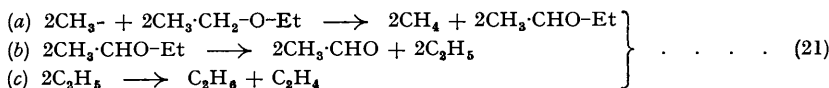

involves the following thermochemical contributions if we take the energy of opening one bond in a double bond as half the total for breaking the double bond, in step (b) and step (c) :

$$\begin{aligned} \text{For step (a)} &- 2D(\text{CH}_3\text{-H}) + 2D(\text{C}_\alpha\text{-H}) \\ (b) &2D(\text{C-O}) - D(\text{C=O}) \\ (c) &D(\text{C-H}) - D(\text{-CH}) - \frac{1}{2}D(\text{C=C}) \end{aligned}$$

Assuming additive bond strengths, which is a sufficient approximation, the heat change in step (a) cancels. Actually the energy required to break the C-H bond in ether is probably rather lower than that to break the C-H bond in methane, but, as will appear, the effect of the approximation is not serious.

The net heat of disposal of the methyl radicals according to reaction (21) is thus

$$\begin{aligned} &2D(\text{C-O}) - D(\text{C=O}) - \frac{1}{2}D(\text{C=C}) \\ &= 2(76.5) - 160 - \frac{1}{2}(123) \\ &= -68.5 \text{ kcal.} \end{aligned}$$

as compared with -71.14 for the disposal of methyl radicals in forming ethane directly. Although the absolute accuracy of these values may not be high, they are self-consistent, and since reaction (21) occurs to the extent of only 2.5% of reaction (13), the error in neglecting it is of the order $0.025 \times (71.14 - 68.5) = 0.07$ kcal., which is inconsiderable compared with the overall probable error.

With the present calorimetric data, a value can also be computed for the bond strength $D(\text{CH}_3\text{-Mg})$. Inserting the values previously used in (10.3), we have $D(\text{CH}_3\text{-Mg}) = 60.27 + D(\text{Mg-I}) + \frac{1}{2}Q_B$. If we assume $D(\text{Mg-I})$ is half the heat of formation of magnesium iodide recorded by Bichowsky and Rossini (*op. cit.*, pp. 144, 340), we have $D(\text{Mg-I}) = 68.45$ kcal. Such an assumption is not unreasonable if MgI_2 (gas) is mainly covalent in character, as is likely owing to the relative sizes of Mg^{++} and I^- . Then

$$D(\text{CH}_3\text{-Mg}) = 60.27 + 68.46 - 51.7 - q_1 - q_4 - \frac{1}{2}q_2 - \frac{1}{2}q_5.$$

If, further, $q_1 \approx -q_4$, *i.e.*, the heats of solvation of gaseous RMgI and gaseous MgI_2 by ether are taken as equal, and we insert the previously used values for q_2 and q_5 , we have

$$D(\text{CH}_3\text{-Mg}) = 67.0 \text{ kcal.}$$

It is not yet possible to compute the probable error in this result.

Finally, it may be pointed out that the value $D(\text{CH}_3\text{-I}) = 54.75 \pm 1.4$ kcals. is in good agreement with the value of 54.0 kcals. calculated purely from kinetic data by Butler and Polanyi (*Trans. Faraday Soc.*, 1943, **39**, 19). This must be regarded as substantial support for the kinetic calculations made by these authors.

Further work is in hand to extend the investigation to the reactions $\text{R}\cdot\text{MgI} + \text{HI} = \text{RH} + \text{MgI}_2$ ($\text{R} = \text{CH}_3$, etc.), since it is unlikely, on theoretical grounds, that the reactions corresponding with (6) and (7) will proceed as smoothly in the case of the higher alkyls, though their suppression by adding excess of magnesium iodide may be effective.

Other halogens are also being investigated in the same way.

QUEEN'S UNIVERSITY, BELFAST.

[Received, July 31st, 1947.]
