

46. *The Automatic Recording of Freezing-point Curves.*

By E. F. G. HERINGTON and R. HANDLEY.

The methods in general use for securing adequate mixing of the solid and liquid during the determination of purity by the freezing-point method are reviewed, and modifications of technique are described which avoid some of the difficulties inherent in the current procedures.

RECORDS of the variation of temperature with time obtained during the freezing of a liquid are now widely used as the basis of a test for chemical purity. The conditions under which such curves can be employed to determine the impurity in a given sample have been discussed by a number of investigators (White, *J. Physical Chem.*, 1920, **24**, 393; Mair, Glasgow, and Rossini, *J. Res. Nat. Bur. Stand.*, 1941, **26**, 591; Taylor and Rossini, *ibid.*, 1944, **32**, 1947; Glasgow, Streiff, and Rossini, *ibid.*, 1945, **35**, 355; Stull, *Ind. Eng. Chem., Anal.*, 1946, **18**, 234; Schwab and Wichers, "Temperature, its measurement and control in science and industry," p. 256; Glasgow, Beadle, Axilrod, and Rossini, *Ind. Eng. Chem., Anal.*, 1948, **20**, 460).

Essential conditions for the application of the freezing-point method are the maintenance of thermodynamic equilibrium between the liquid and crystallised solid while heat is withdrawn from the system at a controlled rate. These conditions are usually maintained by stirring vigorously and by using a cooling bath some 80° lower in temperature than the freezing point of the sample under investigation. The rate of cooling is selected by varying the gas pressure

in the jacket surrounding the specimen during the preliminary cooling. The temperature of the solid-liquid system can be measured by means of a platinum resistance thermometer and the time-temperature curve can be obtained manually but this method is so laborious that Stull (*loc. cit.*) has developed an automatic temperature recorder which is activated by a small platinum resistance thermometer. We have recently described an apparatus for recording temperature changes which makes use of a thermistor as the temperature-sensitive element (Herington and Handley, *J. Sci. Inst.*, 1948, **25**, 434). For any desired temperature sensitivity a more robust recorder can be used with a thermistor than is required by a platinum resistance thermometer, and moreover the heat capacity of a thermistor is very small. The advantages of using small thermometers of low heat capacity in the freezing-curve technique were recognised early in the history of the subject by White (*loc. cit.*).

Various types of motor-driven stirrers which may be used in the freezing-point apparatus have been described by Rossini *et al.* (*loc. cit.*) but these all cease to operate when only a fraction of the liquid has frozen. This failure of the stirrer affects the rate of cooling and as a result a change of direction in the curve suddenly appears at the point where the stirrer stops (see

FIG. 1.

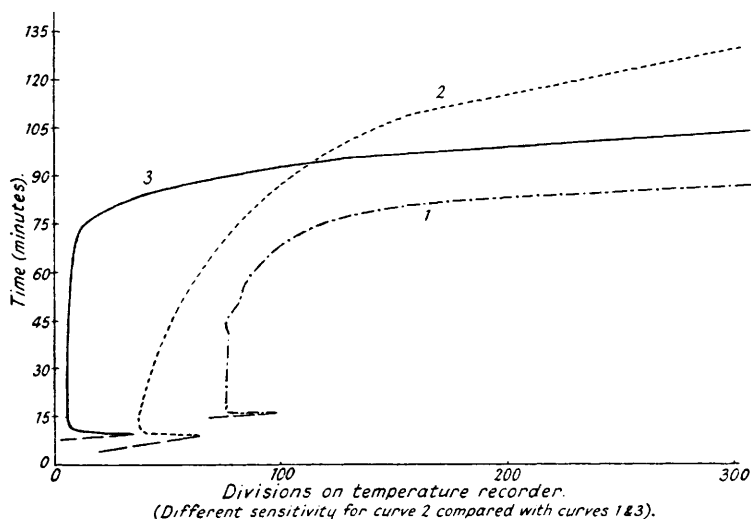

Curve 1.—Obtained with mechanical stirrer.
Curves 2 and 3.—Obtained with apparatus described in this paper.

Fig. 1, curve 1). Inspection of curves obtained by other observers reveals that this behaviour is common and is not peculiar to the mechanically-stirred equipment which we used at the outset of our work. In motor-stirred apparatus the liquid is usually protected from contact with atmospheric moisture by the passage over the liquid surface of a stream of purified air which is allowed to escape through the gland around the shaft of the stirrer.

An alternative method for securing mixing and preventing contact with moist air is to use a sealed-in stirrer operated by a solenoid (Stull, *loc. cit.*), but in this case also the stirrer stops at rather an early stage during the freezing and it is necessary to ensure that no electrical interference is produced in the temperature-measuring circuit by the current in the solenoid.

Schwab and Wichers (*loc. cit.*) have sought to overcome these difficulties by employing a stream of gas bubbles introduced into the liquid through a fine sintered-glass diaphragm. This method has much to recommend it but is not particularly suitable for work when a large number of compounds is to be examined, because of the difficulty of cleaning and drying the sintered-glass plates.

In the apparatus we describe, adequate mixing has been obtained by applying a pulsating gas pressure to the liquid surface in such a way as to produce oscillations in a U-shaped column of the liquid being frozen. Thus mixing of the liquid phase continues until practically all the specimen has frozen while at the same time the material is kept out of contact with moist air. The apparatus is easily cleaned and only 10 c.c. of liquid are required for a determination of the freezing-point curve.

EXPERIMENTAL.

The temperature-recording equipment and the freezing-point apparatus will be discussed separately although they are in fact interdependent units.

Recording of Temperature Changes.—The thermometric equipment used was similar to that described previously as suitable for temperatures from -40° to 140° (Herington and Handley, *loc. cit.*), except that a Tinsley D.C. amplifier and pen recording millivolt-meter have replaced the photographically-recording galvanometer. A constant-voltage transformer smooths the input to the amplifier. The amplifier and recorder have two sensitivity ranges corresponding to 5 and 20 mv. for a full-scale deflection on the chart. A less sensitive galvanometer has been incorporated in the circuit to assist in the preliminary balancing of the bridge and press-button switch-gear has been used so that the out-of-balance current of the bridge can be fed to the recorder or galvanometer at will.

As an indication of the sensitivity which can now be obtained it has been established that a full-scale deflection of 100 divisions ($3\frac{1}{2}$ in.) is equal to a difference of 0.24° for temperatures around 5.5° with use of the 5-mv. range on the recorder and a thermistor of approx. 2000 ohms resistance at room temperature when there is an E.M.F. of 4 volts across the bridge.

Thermistors can be used at temperatures as low as -130° and may thus be employed, for example, to study the freezing-point characteristics of samples of *n*-pentane. We are indebted to Messrs. Standard Telephones and Cables Ltd. for a special type F thermistor having a resistance at room temperature of 200 ohms which increases to approx. 2.5 megohms at -130° . A sensitivity of 0.62° per 100-divisions deflection of the recorder pen at -130° has been obtained by using this thermistor as part of one of the variable arms of a bridge of 11 megohms with two ratio arms of 1 megohm each, and with 120 volts from a dry battery applied across the bridge.

Vapour-pressure thermometers constructed according to the design of Stock (*Z. Electrochem.*, 1923, 29, 354), but with an additional pocket for the thermistor, may be used for the calibration of thermistors at low temperatures. The temperature during the calibration must be allowed to fall slowly in order to avoid difficulties which may arise from the different speeds of response of the two temperature-sensitive elements.

Freezing-point Apparatus.—The dimensions of the apparatus are of some importance and are indicated in Fig. 2 which is drawn to scale. A fluctuating gas pressure is produced in the gas line *F* by means of the pulsing meter *E*. The construction of this meter and its use in another connection have been described in a communication from this laboratory (Preston and Worthington, *Chem. and Ind.*, 1947, p. 612). Compressed air for working the meter has been obtained from a large compressor delivering gas at 20 lbs. per sq. in., but we have established that a satisfactory source is an ordinary small rotating blower of the type commonly used by glass blowers. The air stream causes the pressure to rise in the gas line *F* until the mercury is driven over the narrow loop in *E*, and then the pressure in *F* suddenly drops. These pressure fluctuations set up oscillations of the liquid in the *U* tube. The gas above the liquid in the left-hand limb of the *U* tube is alternately compressed and expanded by reason of the pressure pulses, and this produces oscillations in the mercury manometer *M*. The volume of the gas in the compression chamber *L* is fairly critical and can be adjusted when the apparatus is first set up by varying the amount of mercury in *L* until the best mixing of the liquid in the *U* tube is obtained. The movement of the mercury in *M* gives a visual indication of the rate and magnitude of the surging of the liquid which is being frozen. The main air stream passes to waste after traversing the tap *T*, immersed in liquid air, which has been inserted to reduce the vapour pressure of mercury in the effluent gas. The gas which pulsates to and fro immediately above the liquid in the right-hand limb of the *U* tube slowly interchanges with the gas in the line *F*. The liquid sample is protected from any impurities in this main air line by the column of silica gel *G*.

Efficient mixing in the *U* tube is produced by the stainless-steel helices of external diameter $\frac{3}{8}$ in., made of wire of $\frac{1}{16}$ -in. diameter.

The *U* tube has square corners to allow the thermistor pocket to terminate at a point very near the bottom of the left hand limb. The position of the sensitive thermistor tip is important as visual inspection has shown that the last drops of liquid collect at this point at a time when the whole charge is nearly frozen. The thermistor is inserted in the pocket so that the sensitive tip is 1 mm. from the bottom of the inside of the pocket.

The design of the helices was conditioned by the following observations. Adequate mixing does not occur if the *U* tube is employed without helices, for the liquid then moves as a whole with merely local turbulence. On the other hand, restriction of free movement by too many baffles causes the liquid to become trapped in small pockets, and then the thermistor fails to record the temperature of the bulk liquid-solid mixture. The result of inadequate mixing is to produce a freezing curve of the wrong shape (see page 203 for a discussion on the shape of the curve).

The gas in the left-hand section of the *U* tube is in a closed system bounded by the mercury in the manometer *M* on one side and by the liquid in the freezing-point apparatus on the other, and therefore as the system cools the pressure of this gas falls. The average gas pressure in the other limb of the *U* tube however remains constant, because as the temperature falls more air is taken in from the line *F*. The pressures in the two sections can be equalised by manipulating the tap *J*, and this is done from time to time during the preliminary cooling.

Cooling media suitable for different freezing temperatures have been suggested elsewhere (*e.g.*, Glasgow, Streiff, and Rossini, *loc. cit.*). The rate of cooling is adjusted by varying the gas pressure in the Dewar jacket *P* during the preliminary stages of cooling. The jacket is silvered except for two strips 0.5×8 cm. which are used as inspection windows. The jacket *P* can be evacuated by means of a mercury-vapour pump backed by a Metrovac oil pump with a trap immersed in liquid nitrogen inserted in the gas line to remove traces of mercury vapour (not shown in Fig. 2). The system of vessels, *A*, *B*, *C*, and *D* (Fig. 2) has proved to be useful for the introduction of controlled amounts of air to the vacuum jacket. The approximate volumes used were *A* = 0.6 c.c., *B* = 500 c.c., *C* = 1.2 c.c., and *D* = 150 c.c. Dry air at atmospheric pressure is admitted into *A*, and portions of this mass of gas can be expanded

into *B*, *C*, and *D*, and finally a selected volume of this gas at a low pressure can be admitted to the jacket *P*.

The U tube must be held symmetrically within the jacketed vessel *P*, and centring of the tube is ensured by the wooden platform *Q* which is held rigidly in position by a collar (see Fig. 2).

The method chosen to induce crystallisation in the slightly supercooled liquid depends upon circumstances. A convenient method, when it can be applied, is to employ the apparatus *Y* (Fig. 2) which can be connected to the U tube by interchange with the ground glass joint *a*. Two steel ball bearings, 3/32" in diameter, are cooled in the vertical tube of *Y* just before seeding is required. These balls can be moved up the tube by means of a permanent magnet and allowed to fall down the sloping

FIG. 2.

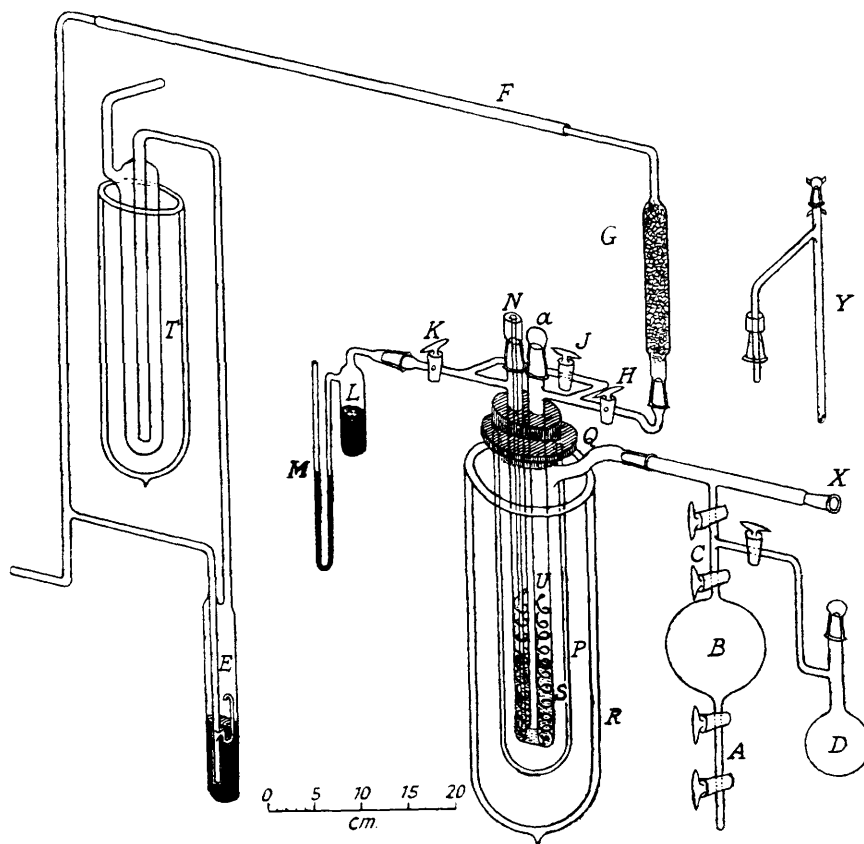

- | | |
|--|---|
| <i>A</i> , <i>B</i> , <i>C</i> , <i>D</i> . Gas volumes for doser. | <i>R</i> . Dewar flask containing cooling medium. |
| <i>E</i> . Pulsing meter. | <i>S</i> . Stainless steel helices. |
| <i>F</i> . Gas line. | <i>T</i> . Trap in effluent gas line. |
| <i>G</i> . Silica gel. | <i>U</i> . U tube containing liquid under examination (46 cm. in length, tube 11 mm. I.D.). |
| <i>H</i> , <i>J</i> , <i>K</i> . Taps, 4 mm. bore. | <i>X</i> . Joint to high vacuum line. |
| <i>L</i> . Compression chamber. | <i>a</i> . Glass cap (B. 19) which can be interchanged with seeding arrangement <i>Y</i> . |
| <i>M</i> . Mercury manometer. | <i>Y</i> . Seeding apparatus containing ball bearings. |
| <i>N</i> . Cap carrying thermistor pocket. | |
| <i>P</i> . Dewar flask with variable vacuum. | |
| <i>Q</i> . Wooden platform supporting U tube. | |

tube into the right-hand side of the U tube when crystallisation is to be induced. This method does not always produce successful results with liquids which supercool readily or with liquids which freeze at a very low temperature, but where this technique can be employed contamination of the sample with moisture is avoided. An alternative method is to insert a cooled stainless-steel rod through *a* (Fig. 2) while the pulses are momentarily stopped, but even this simple procedure can yield erratic results with substances having more than one crystalline form (e.g., α -picoline). In such circumstances an injector made by passing a thin stainless-steel rod down the centre of a close-fitting glass tube has proved useful because a plug of solid can be caused to crystallise in the tip of the ejector and can then be held until seeding is required at some temperature at which the desired crystalline form is stable. The solid can be ejected into the supercooled liquid by a thrust on the stainless-steel plunger.

The only heat liberated by the stirring in the present equipment is that produced by the friction of the liquid against the obstacles used to produce turbulence. Direct measurement on a typical example has shown that at 106 pulses per minute this heat is generated at approx. 7% of the rate at which heat is extracted in the cooling process.

Recording of the Freezing-point Curves.—10 C.c. of liquid samples may be used in the apparatus, although it is preferable to use double this amount. To carry out a determination the apparatus is assembled, the resistances in the arms of the Wheatstone bridge are adjusted to values suitable for the temperature at which freezing will occur, pressure in the two limbs of the U tube is equalised, and the pulses are started at a rate of 106 per minute. The Dewar vessel *R* (Fig. 2) containing the refrigerant is placed in position and, if a very wide temperature interval has to be covered before the freezing temperature is reached, dry air is admitted to the vacuum jacket *P* through a tap on the vacuum line (not shown) in order to accelerate the cooling. The jacket *P* is evacuated as soon as the temperature has fallen sufficiently, and doses of air at low pressure are admitted through the system *A, B, C, D*, until the desired cooling rate has been obtained. Rates are normally selected so that the total time of freezing is approx. 1½ hours. From time to time the levels of the liquid in the U tube are balanced by means of tap *J* (Fig. 2).

Crystallisation is induced by one of the methods described above. The liquid levels are balanced immediately following each attempt at seeding, but are not again adjusted once crystallisation has started. The temperature–time curve is then plotted on the recorder.

TREATMENT OF EXPERIMENTAL OBSERVATIONS.

The theory of the use of freezing-point curves for determining impurities has frequently been discussed (see page 199 for references). The assumption that the main component crystallises first, leaving the impurity in the liquid is common to all these treatments.

White (*loc. cit.*) appears to have been the first to recognise that, if under these conditions the depression of the freezing point is proportional to the mol. fraction of impurity in the liquid, then the temperature difference between the initial freezing point and that when half the material is frozen is equal to the temperature depression originally produced by the impurity. The molar percentage of impurity and the true freezing point of the pure material can thus be found.

Rossini *et al.* (*loc. cit.*) have discussed a thermodynamically more exact approach which involves higher approximations, but for many purposes the simpler treatment appears to be sufficient, particularly since, as Schwab and Wichers (*loc. cit.*) point out, the rate of cooling is rarely, if ever, exactly constant. Schwab and Wichers therefore suggest that the amount of impurity be calculated by proportional parts from a freezing-point curve of the original material and from another curve for the same material obtained after a known amount of impurity has been added. Both curves should be measured under the same conditions.

In view of the uncertainties inherent in the technique we have used the simple method of calculation employed by Stull (*i.e.*, essentially White's method) when the cryoscopic constant has already been reported and when a high accuracy is not required. If a higher accuracy is needed or if the cryoscopic constant is not known, Schwab and Wichers' method of proportional parts is used.

The efficacy of any equipment for determining freezing-point curves can be examined by analysing the shape of the curves. Subject to the usual assumptions it follows from the argument used by White that

$$[(1 - x)/x]\Delta t = t^{\circ} \quad \dots \quad (1)$$

where Δt is the difference between the temperature at the initial freezing point at time z_0 and that at time z , x is the fraction frozen at time z , and t° is the depression of the freezing point of the pure component produced by the impurity originally present.

If the cooling rate is constant, then approximately

$$x = (z - z_0)/(z_t - z_0) \quad \dots \quad (2)$$

where z_0 is the time when freezing starts, z_t is the time when all the liquid has frozen, and z is the time when a fraction x is frozen.

The form of these equations shows that, on the temperature–time plot, Δt should increase as z increases, and that the rate of increase of Δt with time should itself increase with z . Fig. 1, curves 2 and 3, shows that smooth curves are obtained with the present apparatus and that they are qualitatively of the correct shape.

If equations (1) and (2) are obeyed, then $[(1 - x)/x]\Delta t$ and $[(z_t - z)/(z - z_0)]\Delta t$ should be constant. The table contains the more detailed analysis of some experimental results obtained with 20-c.c. samples for which x has been calculated from equation (2) and Δt is expressed in arbitrary units equal to the deflection of the galvanometer in divisions. These units have different values in terms of temperature for the two samples.

Values of $[(1-x)/x]\Delta t$. Total time of curves = 86 mins.

x , calc. from equation (2).	[[$(1-x)/x$] Δt .		x , calc. from equation (2).	[[$(1-x)/x$] Δt .	
	Benzene, 99.73 mols.-% pure.	2 : 6-Lutidine, 99.1 mols.-% pure.		Benzene, 99.73 mols.-% pure.	2 : 6-Lutidine, 99.1 mols.-% pure.
0.1	13.5	23	0.6	12.6	28
0.2	10.0	24	0.7	12.4	24
0.3	10.5	28	0.8	12.0	19
0.4	12.0	30	0.9	9.0	11
0.5	13.0	31			

The table indicates that the curves obey equations (1) and (2) up to $x = 0.70$, and therefore equilibrium between solid and liquid would appear to be maintained until 70% of the charge is frozen.

The freezing-point results for 184 hydrocarbons obtained by the reciprocating-stirrer method recorded in the "Supplement to National Bureau of Standards Circular 398" (January 1st, 1949) have been analysed by us to provide a standard of accuracy against which to compare the performance of our apparatus. The results in the Circular are expressed as mol.-% of impurity \pm a certain percentage. The parameter most directly measurable by the freezing-point method is the impurity, so that it is natural to express the uncertainty of the results as a fraction of the impurity. The mean value of the ratio \pm percentage/mol. percentage for the 184 hydrocarbons listed is 0.54, *i.e.*, the value designated as \pm is usually approximately one-half of the impurity determined. Thus a sample would be described as 99.6 \pm 0.2 mols.-% pure.

A sample of benzene which was found to be 99.90 mols.-% pure in the present apparatus, with the method of calculation employed by Stull and a cryoscopic constant of 5.12° per 1000 g. of benzene gave a value of 99.77 mols.-% pure by the proportional-parts method. To the same sample of benzene was added in succession 0.048 and 0.144 mol.-% of impurity, *i.e.*, impurity in the ratio 1 : 3, and the depressions of temperature when the samples were half frozen were as 1 : 3.5.

The apparatus described thus appears to yield results at least as accurate as the methods in common use.

Our thanks are due to Mr. A. J. Cook for assistance with the experimental work and to Mr. C. G. Andrews for carrying out the construction of numerous models in glass which were used in the development of the design discussed here. The work described above has been carried out as part of the research programme of the Chemical Research Laboratory and this paper is published by permission of the Director of the Laboratory.

CHEMICAL RESEARCH LABORATORY,
TEDDINGTON, MIDDLESEX.

[Received, August 17th, 1949.]