

287. *The Liquid Dinitrogen Tetroxide Solvent System. Part IV. The Dielectric Constant, Refractive Index, and Polarisation of Liquid Dinitrogen Tetroxide : the Nature of Solutions.*

By C. C. ADDISON, H. C. BOLTON, and J. LEWIS.

The dielectric constant of liquid dinitrogen tetroxide has been found to be 2.42 at 18°. Values of the refractive index are recorded for several wave-lengths. The molar polarisation, and molar refractivity, have values 26.5 c.c. and 15.2 c.c., respectively. Factors responsible for this difference are discussed, and the influence of low dielectric constant on the nature of solutions in liquid dinitrogen tetroxide is considered.

In a consideration of electrical phenomena and mode of chemical reaction in liquid dinitrogen tetroxide, a knowledge of the dielectric constant is fundamental. Schlundt (*J. Physical Chem.*, 1904, 8, 122), using Drude's method (*Z. physikal. Chem.*, 1897, 23, 267), obtained the values 2.56 (at 15°) and 2.6 (at -40°) for the dielectric constant of dinitrogen tetroxide. This value, of the same order as that of benzene, *viz.*, 2.284 (van der Maesen, *Physica*, 1949, 15, 481), is very low in comparison with those of water (81.1) and liquid ammonia (17.8 at 15°). It is therefore to be expected, from the Nernst-Thomson rule, that salts dissolved in liquid dinitrogen tetroxide will not undergo appreciable dissociation into free ions. In accordance with this, it has been observed that solution of alkylammonium salts in dinitrogen tetroxide have a negligible electrical conductivity. However, the reactions of these salts in solution are ionic in character (Part I, *J.*, 1949, S 211), and certain compounds, when dissolved in the tetroxide, give conducting solutions. For these reasons, it was considered necessary to redetermine the dielectric constant of liquid dinitrogen tetroxide.

The refractive index of the liquid at infinite wave-length has also been determined in order to obtain information on the relative significance of the various forms of polarisation in the pure liquid.

EXPERIMENTAL.

Construction of Condenser.—The dielectric constant was determined by comparing the capacity of a specially prepared condenser in air and in liquid dinitrogen tetroxide. In view of the low order of the dielectric constant, it was necessary to increase, as far as was practicable, the area of the plates, and to decrease their distance apart. A pattern commonly used for such a purpose employs two concentric glass tubes having the annular surfaces silver-plated. The advantages of this pattern are, first, that a high capacity is obtained in a small volume, thus minimising the amount of liquid required, and secondly, that the space between the plates is shielded electrically from any stray fields. Silver could not be used in this determination, as it is attacked by the tetroxide. Pure nickel is not attacked, and the apparatus used is shown in the figure. The condenser *A* consisted of two concentric cylinders prepared from nickel sheet 1.5 mm. thick. The outer cylinder was 5 cm. long and had a diameter of 2 cm. The inner cylinder was of identical length, and of such a diameter as to give an annular gap of about 1 mm. By this means the stray capacity arising from the spreading of the lines of force from the ends of the condenser was reduced. The cylinders were held rigidly with respect to one another by spacers of thin glass rod pressed into the annulus. The leads *B* (which were continuous with the metal of the cylinders) were 2 × 1.5 mm. nickel strips and were soldered to stout (16 S.W.G.) uncovered copper wires *C*. The condenser was held rigid by embedding the leads *B* in a B 24 ground cone *D* filled with beeswax and picein, as illustrated in the figure.

Conditions of Measurements of Capacity.—The capacity, as measured, is the sum of the true capacity of the condenser and the stray capacity arising mainly from the leads. For accurate measurement of dielectric constant it was necessary (*a*) to manipulate the apparatus so that the stray capacity was kept constant throughout the whole series of measurements, and (*b*) to determine the magnitude of this stray capacity by the use of a standard liquid. Benzene was chosen for this purpose since it has a dielectric constant close to Schlundt's value for dinitrogen tetroxide (*loc. cit.*). Hence the determination of the dielectric constant involves the measurements of three capacities :

$$\begin{aligned} C_1 &= C_s + C \text{ (in air)} \\ C_2 &= C_s + \epsilon_1 C \text{ (in benzene)} \\ C_3 &= C_s + \epsilon_2 C \text{ (in dinitrogen tetroxide)} \end{aligned}$$

where C_s is the stray capacity, and C the capacity of the condenser in air. Hence the dielectric constant of dinitrogen tetroxide is given by :

$$\epsilon_2 = 1 + (C_3 - C_1)(\epsilon_1 - 1)/(C_2 - C_1) \quad \dots \quad (1)$$

Manipulation of Apparatus.—The condenser was washed with water, alcohol, and ether, freed from solvent in a stream of warm, dry nitrogen, and allowed to cool in a vacuum desiccator. The cone *D* carrying the condenser was then fixed rigidly (clamp *E*), and the leads *C* to the electrical circuit were also fixed in position. Throughout each series of measurements the position of condenser and leads

remained unaltered, so that the stray capacity was constant. The vessel *F* was thoroughly dried by the technique described in the previous paper, phosphoric oxide guard tubes were attached at *G* and *H*, and *F* was placed in position as shown in the figure. The total capacity in air (C_1) was then determined. Without any alteration in the position of the apparatus, liquid dinitrogen tetroxide was poured slowly into *F* via the B 14 ground joint *G*, until the condenser was covered. The guard tube was replaced at *G*, and the total capacity C_2 measured. Vessel *F* was then lowered from the condenser, and the latter was immediately washed with water, followed by alcohol and ether, and dried in a stream of nitrogen. A second vessel identical with the first vessel *F* and previously dried, was placed around the condenser, and the capacity in air redetermined to confirm that the condition of the condenser was unchanged. Pure benzene was then added to *F* via *G* until the condenser was covered to exactly the same extent as in the experiment using dinitrogen tetroxide, and the total capacity was determined. For measurement of capacity at other than room temperature, vessel *F* was surrounded by a bath kept at the desired temperature.

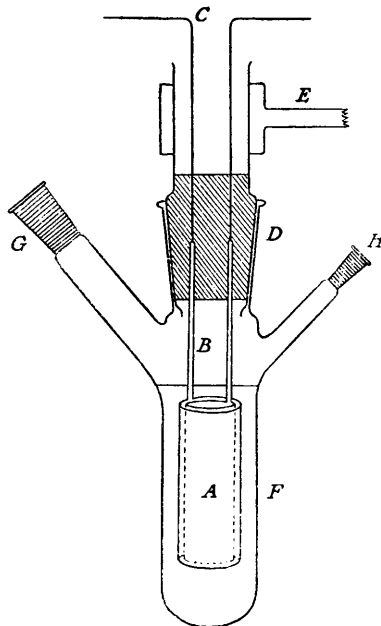

Purification of Materials.—The dinitrogen tetroxide was prepared and purified by the method given in Part III (preceding paper). The benzene was purified by Richards and Shipley's method (*J. Amer. Chem. Soc.*, 1914, **36**, 1825). This has become accepted by many workers (e.g., Hartshorn and Oliver, *Proc. Roy. Soc.*, 1929, *A*, **123**, 664) as suitable for the exhaustive purification of benzene for dielectric-constant measurement, and involves successive treatments with sulphuric acid, sodium hydroxide, distilled water, and mercury; the liquid was finally dried by calcium chloride and sodium wire.

Measurements of Capacity.—Preliminary determinations were carried out as follows: (a) The capacity of the condenser *A* (see figure) was measured directly, a Mullard capacity-measuring bridge Type G.M. 4140/1, and 1000 c./s. oscillator unit Type G.M. 4260 being used. The capacity bridge was calibrated by using a Marconi Circuit Magnification Meter Type T.F. 329 G., and also a Muirhead variable air-condenser Type A-430-BMS. This method indicated that the dielectric constant was small, of the order of 2.4. The final value was determined by the following variation of the usual substitution method, which is more accurate than method (a).

(b) A condenser *D* and a Sullivan variable air-condenser *E* were placed in series, and their total capacity was measured. The test condenser *A* was placed across *D* and *E*, and *E* adjusted until the balance was restored. If E_1 is the second value of the air condenser, then

$$C_A = C_D^2(C_E - C_{E_1}) / (C_D + C_E)(C_D + C_{E_1}) \dots \dots \dots (2)$$

The capacity of *D*, which was measured accurately, was only slightly greater than that of *A*; therefore, the value of $C_E - C_{E_1}$ was large, and in consequence the errors in reading the scale *E* were reduced.

Refractive Index.—This value was determined by the method of minimum deviation, a hollow 60° glass prism and a 6" Precision Instrument Co. Spectrometer being used. Values were obtained at four different wave-lengths by means of mercury and sodium vapour lamps.

RESULTS AND DISCUSSION.

By using equation (2) and method (b) above, the capacity of condenser *A* was determined with air, benzene, and liquid dinitrogen tetroxide (C_1 , C_2 , and C_3 , respectively in equation 1) as dielectrics. The results are given in Table I. The series of results given for the capacity of condenser *A* were obtained for different settings of the variable condenser, and represent the order of reproducibility of the capacity measurements. All measurements recorded in Table I were carried out at 18°, and at a frequency of 1000 c./s. The error attached to the final value of ϵ cannot be greater than 1%.

Influence of Temperature on Dielectric Constant.—When the temperature of the liquid dinitrogen tetroxide was reduced from 18° to -5° by surrounding vessel *F* by a freezing mixture, there was an almost negligible change in the dielectric constant. Since the proportion of

TABLE I.

Dielectric :	Air.	Benzene.	Liquid N ₂ O ₄ .
Capacity A ($\mu\mu\text{F.}$)	58.8	123.2	130.1
	58.6	123.5	130.1
	58.0	123.5	130.4
	58.8	123.9	130.3
	—	123.6	130.8
Mean capacity ($\mu\mu\text{F.}$)	58.5	123.5	130.3
Dielectric constant ϵ	1	2.284 *	2.42 (calc. by eqn. 1)

* Van der Maesen (*loc. cit.*).

nitrogen dioxide in the liquid tetroxide varies appreciably over this temperature range, it may be of some significance that the dielectric constant is almost independent of temperature. The measurements obtained showed a slight increase in the value of the dielectric constant at lower temperatures, but since the change in capacity was little more than the experimental error of capacity measurement, no attempt has been made to assess the temperature coefficient quantitatively.

Refractive Index.—The values determined for a series of wave-lengths are given in Table II.

TABLE II.

Wave-length, A.	Angle of * minimum deviation, D.	<i>n</i> (at 20°).	Wave-length, A.	Angle of * minimum deviation, D.	<i>n</i> (at 20°).
5893 (Sodium)	30° 19.5'	1.420	4916.4 (Hg blue-green)	31° 11.7'	1.431
5460.7 (Hg green)	30° 38.5'	1.424	4358.3 (Hg blue)	32° 6.2'	1.442

* Angle of prism = 59° 47.9'.

The measured angle ($2D$) was reproducible within 1', giving values of n which are correct to four significant figures. The refractive index at infinite wave-length (n_∞) was determined from Cauchy's relation $n_\lambda = n_\infty + a/\lambda^2$. Extrapolation of the straight line obtained by plotting n_λ against $1/\lambda^2$ gave the value $n_\infty = 1.394$.

Significance of Results.—The results given above are of value in the study of two separate aspects of the chemistry of liquid dinitrogen tetroxide, *i.e.*, (a) the nature of solutions in this medium, and (b) the constitution of the pure liquid itself.

(a) In a liquid having a dielectric constant as low as 2.42, the coulombic forces of attraction between oppositely charged ions will be sufficiently large to prevent their separation into free ions. It is clear from the work of Fuoss and Kraus (*J. Amer. Chem. Soc.*, 1933, **55**, 476, *et seq.*) that in such a liquid a dissolved salt will exist almost entirely in the form of ion-pairs in dilute solution; increase in concentration may result in a more complex type of ion association, such as the formation of triple ions. This is considered to be the state of solutions of alkylammonium salts dissolved in liquid dinitrogen tetroxide. Ion-pairs do not contribute to the electrical conductivity of the solution, and in consequence the electrical conductivities of freshly prepared solutions of alkylammonium salts in dinitrogen tetroxide at concentrations as high as 30% are less than 10^{-8} ohm $^{-1}$ cm. $^{-1}$. However, this concept is not necessarily in conflict with the apparently ionic nature of reactions in liquid dinitrogen tetroxide (Part I, *J.*, 1949, S 211; Part V, following paper); but such reactions must be considered as occurring as a result of collision between ion-pairs rather than free ions. In reactions between ions, or ion-pairs, the activation energy is influenced by the dielectric constant; but it is only the rate, and not the character, of the reaction which is so influenced (Moelwyn-Hughes, "Kinetics of Reactions in Solution," Oxford Univ. Press, 1947, p. 92). Certain compounds (*e.g.*, diethylnitrosamine) when added to liquid dinitrogen tetroxide give rise to strongly conducting solutions. In the interpretation of these high conductivities, the increase in dielectric constant of the medium arising from the addition of nitrosamine to dinitrogen tetroxide is no less important than the ionic character of the compound formed between these two components. This work is described in Part VI (*J.*, 1950, 1303).

(b) The data given above may be used to determine the difference between the molar polarisation (P) and the molar refraction ($[R]$) for pure liquid dinitrogen tetroxide. Using the expression

$$\text{Molar polarisation} = P = M(\epsilon - 1)/\rho(\epsilon + 2)$$

and accepting the value for the density (ρ) as 1.444 at 20° (Ramsay and Shields, *J.*, 1893, **63**, 1089), we find that $P = 26.5$ c.c. Substituting the value of the refractive index at infinite wave-length (n_∞) into the expression

$$\text{Molar refraction} = [R] = M(n^2 - 1)/\rho(n^2 + 2)$$

we find $[R] = 15.2$ c.c.

In the absence of permanent dipoles and infra-red polarisation effects, P will equal $[R]$. This state is approached in a number of non-polar liquids; *e.g.*, assuming the value $n_\infty = 1.476$ for benzene (by extrapolation from Brühl's data, *Z. physikal. Chem.*, 1897, **22**, 373), we find $P = 34.68$ c.c. and $[R] = 32.92$ c.c. The divergence observed between P and $[R]$ for liquid dinitrogen tetroxide is therefore to be attributed to one or both of the above factors. Although the molar polarisation determined from the static dielectric constant ϵ is the sum of the electronic polarisation, the polarisation due to permanent dipoles, and atomic polarisation (*i.e.*, the polarisation arising from nuclear vibrations, due to absorption in the infra-red), the contribution

made by the latter factor is normally relatively so small in liquids having permanent dipole moments that it is often neglected. In purely non-polar liquids, where there is no variation in ϵ with temperature, any discrepancy between $[R]$ and P is associated with infra-red absorption, since, as the value of n used is that at infinite wave-length, $[R]$ is a true measure of the electronic polarisation. However, in liquid dinitrogen tetroxide the position is more complex, since it is not possible to deduce from the near-zero value of $d\epsilon/dT$ that no dipolar components are present. This arises from the following considerations: (a) The dipole moment of the dinitrogen tetroxide molecule has been shown by Williams, Schwengel, and Winning (*J. Amer. Chem. Soc.*, 1936, **58**, 197) to differ little, if at all, from zero, but the nitrogen dioxide molecule has a dipole moment (in the gaseous state) of 0.58 D. at 25°. (b) The concentration of nitrogen dioxide increases with temperature. (c) In a polar liquid, the total polarisation decreases with increasing temperature. Thus the temperature independence of dielectric constant of liquid dinitrogen tetroxide could be achieved by a balance between the factors (b) and (c).

It is not yet possible to assess the extent to which atomic polarisation is responsible for the difference between P and $[R]$, but this difference (11.3 c.c.) is significantly greater than that usually attributed to infra-red absorption effects. Unless this factor is completely responsible, it follows from the above that the discrepancy may be attributed to the presence of some polar component, in spite of the constancy of ϵ with temperature. In order to determine the extent to which the nitrogen dioxide molecules present in the liquid state could be responsible for this difference, the equation

$$\left[\left(\frac{\epsilon - 1}{\epsilon + 2} \right) - \left(\frac{n^2 - 1}{n^2 + 2} \right) \right] \frac{f_1 M_1 + f_2 M_2}{\rho} = \frac{4\pi N}{3} f_2 \left(\frac{\mu^2}{3kT} \right) \dots \dots \dots (3)$$

(see Debye, "Polar Molecules," Chemical Catalog Co., 1929, p. 45) has been employed to calculate the contribution made by the nitrogen dioxide to the polarisation. If it is assumed (a) that Williams, Schwengel, and Winning's dipole moment values (*loc. cit.*) are not appreciably different from the values in the liquid state, and (b) that at 20° the liquid tetroxide contains 0.7% of nitrogen dioxide (Soné, *Sci. Rep. Tohoku Imp. Univ.*, 1922, **11**, 139), the nitrogen dioxide makes a negligible contribution (<0.04 c.c.) to the $P-[R]$ difference.

If we continue the assumption that atomic polarisation may be responsible for only part of the $P-[R]$ difference, it becomes necessary to seek an alternative dipolar component which could be present in the liquid state. There is considerable evidence, from its purely chemical reactions, that the dinitrogen tetroxide molecules in the liquid state react as nitrosyl nitrate. Angus, Jones, and Phillips (*Nature*, 1949, **164**, 433) have represented the molecule in the convenient form $\text{NO}^{\delta+}-\text{NO}_3^{\delta-}$. In the limit, this may be represented by an ion-pair $[\text{NO}^+][\text{NO}_3^-]$. These forms of the molecule would possess dipolar character, and an equilibrium

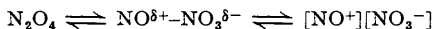

could account for all or part of the difference between P and $[R]$. This equilibrium is postulated for the liquid phase; only one form of the molecule will occur in the solid, and polar forms of the molecules are unlikely in the gaseous state, so that this equilibrium is not in conflict with (a) crystallographic evidence for the structure of the molecule (Broadley and Robertson, *Nature*, 1949, **164**, 915), (b) the absence of a dipole moment for the dinitrogen tetroxide molecule in the gaseous state, or (c) the low electrical conductivity of the liquid (Part III, preceding paper).

If $[\text{NO}^+][\text{NO}_3^-]$ is the polar constituent, then in equation (3), $M_1 = M_2$, and it follows that at any given temperature $f_2 \mu_2^2$ has a constant value. If we assume an arbitrary value of 3 Å. for the inter-ion distance in the ion pair, and that the whole $P - [R]$ difference arises from the presence of this component, then it may be calculated from the above relationship that the mol.-fraction f_2 of ion pairs in the liquid is as low as 0.001.

It is relevant that Goulde (Ph.D. Thesis, Univ. of London, 1949) has observed that the Raman spectrum of liquid dinitrogen tetroxide at -10° (*i.e.*, immediately above its m. p.) shows no frequency in that region of the spectrum which is characteristic of the NO^+ ion. However, it has been stated above that if the difference between molar polarisation and refraction is to be attributed to the presence of a polar species, the concentration of that species should increase with temperature, so that a study of Raman spectra over a temperature range is necessary before the possibility of an equilibrium in the liquid state can be dismissed.

We are indebted to the Department of Scientific and Industrial Research for a Maintenance Grant to one of us (J. L.).