

p-Menthane-2 : 3-diols. Part III.\* Reductions of Diosphenol with Aluminium isoPropoxide and with Lithium Aluminium Hydride.

By A. KILLEN MACBETH and W. G. P. ROBERTSON.

[Reprint Order No. 4534.]

The diol formed on reduction of diosphenol with aluminium isopropoxide is mainly ( $\pm$ )-*trans*-2-hydroxyneomenthol. Appreciable amounts of ( $\pm$ )-*cis*-2-hydroxyisomenthol and, probably, ( $\pm$ )-*cis*-2-hydroxyneomenthol are also produced, and the presence of ( $\pm$ )-*trans*-2-hydroxyisomenthol is established. Lithium aluminium hydride reduction under all conditions tried yields considerable amounts of partially reduced compounds and the yield of glycols is low. The di-*p*-nitrobenzoates of ( $\pm$ )-*trans*-2-hydroxyneomenthol and of, probably, ( $\pm$ )-*cis*-2-hydroxyneomenthol have been isolated.

The reductions with these reagents are of stereochemical interest but are of limited preparative value.

IN the reduction of a number of substituted *cyclohexanones* by aluminium isopropoxide (Jackman, Macbeth, and Mills, *J.*, 1949, 2641) and by lithium aluminium hydride (Noyce and Denney, *J. Amer. Chem. Soc.*, 1950, 72, 5743; Macbeth and Shannon, *J.*, 1952, 2852) the former reagent generally gave a larger proportion of the *cis*-isomer. As the differences are doubtless due to the smaller steric requirements of the reducing step of the lithium aluminium hydride reaction (Trevoy and Brown, *J. Amer. Chem. Soc.*, 1949, 71, 1675) a comparison of the behaviour of the two reagents with diosphenol appeared to be of stereochemical interest.

Reduction of diosphenol by aluminium isopropoxide was slow and the rather poor yield of diol was not improved by a modified procedure (Macbeth and Mills, *J.*, 1949, 2646). Fractional distillation of the crude product obtained by use of 2.5 mols. of aluminium isopropoxide for 13 hr. yielded a glycol fraction of some 23%, with a fore-run of unchanged

\* Part II, *J.*, 1953, 3512.

diosphenol apparently free from products of partial reduction; the yield of mixed glycols was increased to 43% by use of 5 mols. of the *isopropoxide* for 40 hr. Crystallisation of the whole fraction from light petroleum gave ( $\pm$ )-*trans*-2-hydroxyneomenthol (IVa). Fractional crystallisation of the di-*p*-nitrobenzoates of the material from the mother-liquors gave the known esters (Vb) and (VIb) and a new ester, m. p. 165–166°. The previously unknown glycol (Va) was obtained by hydrolysis of (Vb), and the new ester gave a new glycol. Seven of the eight ( $\pm$ )-*p*-menthane-2 : 3-diols being previously known, the new one is presumably the eighth, *cis*-2-hydroxyneomenthol (III).

The formation of ( $\pm$ )-*trans*-2-hydroxyneomenthol as the main product of the reduction of diosphenol by aluminium *isopropoxide* supports the configuration assigned to it (Part II), since consideration of the mechanism of the reduction of carbonyl compounds by aluminium alkoxides (Jackman and Mills, *Nature*, 1949, **164**, 789; Doering and Young, *J. Amer. Chem. Soc.*, 1950, **72**, 630; Jackman, Mills, and Shannon, *ibid.*, 1950, **72**, 4814; Jackman and Macbeth, *J.*, 1952, **3252**) suggests the preferential formation of the more sterically hindered of a pair of epimeric alcohols.

The isomeric ( $\pm$ )-2-hydroxymenthols.

(Only one of the mirror-image forms is shown in each case.)

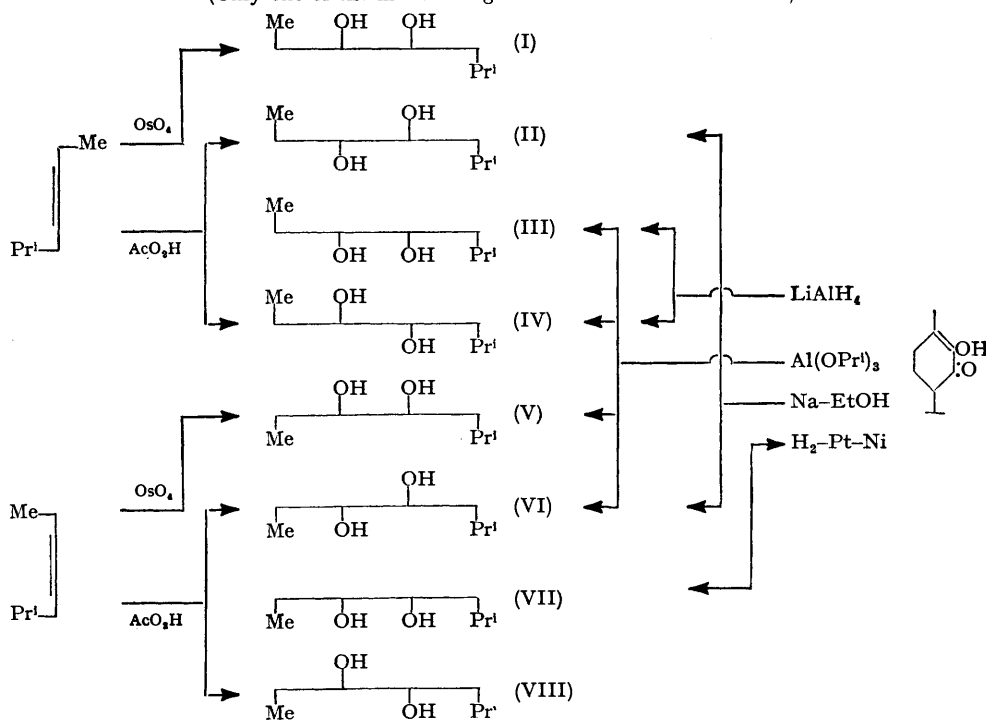

(a) = Glycol. (b) = Di-*p*-nitrobenzoate. (c) Bis-3 : 5-dinitrobenzoate.

| Series                    | (a) | (b)     | (c)  | Series                      | (a)      | (b)     | (c)   |
|---------------------------|-----|---------|------|-----------------------------|----------|---------|-------|
| <i>cis</i> (I) .....      | —   | 163°    | —    | <i>cis-iso</i> (V) .....    | 70·5—71° | 138°    | 143°  |
| <i>trans</i> (II) .....   | 91° | 118     | 218° | <i>trans-iso</i> (VI) ..... | 77       | 166     | 122   |
| <i>cis-neo</i> (III) ...  | 52  | 165—166 | —    | <i>cis-neoiso</i> (VII) ... | 76       | 147—148 | 82—83 |
| <i>trans-neo</i> (IV) ... | 79  | 168     | 173  | <i>trans-neoiso</i> (VIII)  | 69       | 152—153 | 65    |

Reduction of 1 : 2-diketones to glycols by lithium aluminium hydride appears to have been achieved in very few cases—it gives predominantly *cis*-camphane-2 : 3-diol from 2 : 3-camphorquinone (Trevoy and Brown, *loc. cit.*), and the *trans*-glycols from 1 : 2-naphthaquinone, 1 : 2-anthraquinone, and 9 : 10-phenanthraquinone (Booth, Boyland, and Turner, *J.*, 1950, 1188). Reduction of diosphenol by 2, 4, or 10 equivalents of lithium

aluminium anhydride in boiling ether for 3 hr. gave 30%, 40%, and 46% yields respectively of crude glycols. There were large amounts of lower-boiling products; although these might contain hydroxy-ketones, no *p*-nitrobenzoate, semicarbazone, or 2 : 4-dinitrophenylhydrazone could be crystallised; this fraction slowly deposited prisms, m. p. 159—163°, which were not further examined but may be the substance, m. p. 159°, obtained by Shimoyama (*Arch. Pharm.*, 1888, **26**, 403) by the sodium amalgam reduction of diosphenol (Simonsen, "The Terpenes," MacMillan, 1947, Vol. I, p. 419, suggested that this is a pinacone, C<sub>20</sub>H<sub>34</sub>O<sub>4</sub>). Tedious fractional crystallisation of the glycol di-*p*-nitrobenzoates gave (IV*b*) and (III*b*), but (IV*a*) did not crystallise directly from the mixed glycols in this case.

The complete work on the diols and the melting points of the characteristic esters are shown in the chart and Table.

#### EXPERIMENTAL

*Reduction of Diosphenol with Aluminium isoPropoxide.*—(a) To a boiling stock m-solution of aluminium isopropoxide in isopropanol (50 ml.) were added dry isopropanol (50 ml.), and then, dropwise during 8 hr., a solution of diosphenol (10 g.) in isopropanol (100 ml.). The distillate was continuously fractionated through a bead-column 75 cm. in length, and after the addition of diosphenol the fractionation was continued until the distillate no longer gave a test for acetone (13 hr.). A further portion of isopropanol (25 ml.) was removed by more rapid fractionation. The residue was diluted with water (150 ml.) and extracted with benzene (50 + 25 ml.). The extract was washed with 12N-sulphuric acid (30 ml.), 2N-sodium hydroxide (2 × 25 ml.), and water (25 ml.), and dried (MgSO<sub>4</sub>). After removal of the solvent, distillation of the residue gave fractions, (i) colourless crystals (3 g.), b. p. 80—95°/4 mm., and (ii) a viscid colourless oil (2.3 g.), b. p. 110—120°/4 mm. Acidification of the alkaline washings precipitated diosphenol (1 g.). Crystallisation of fraction (i) from light petroleum (b. p. 40—60°) gave diosphenol (2 g.), m. p. 82°. Crystallisation of fraction (ii) from light petroleum (b. p. 40—60°) gave (±)-*trans*-2-hydroxyneomenthol (0.2 g.), m. p. 79° [di-*p*-nitrobenzoate (pale yellow plates from ethanol), m. p. 168°]. Both the glycol and its ester showed no depression of m. p. on admixture with authentic specimens (Part II).

(b) Diosphenol (15 g.) in dry isopropanol (150 ml.) was added to a boiling m-solution of aluminium isopropoxide in isopropanol (150 ml.) during 7 hr. The reduction was continued under reflux in the usual way, a column (100 cm.) packed with single-turn glass helices and a high reflux ratio being used for 40 hr.; 200 ml. of distillate were collected. The residue was worked up in the usual way. Fractionation through a small column of glass helices gave (a) crystalline diosphenol (4 g.), b. p. 85—90°/4 mm., and (b) a colourless viscid oil (6.5 g.), b. p. 112—118°/4 mm. A further 2 g. of diosphenol were recovered from the alkaline washings. Crystallisation of fraction (b) from light petroleum (10 ml.) (b. p. 40—60°) gave (±)-*trans*-2-hydroxyneomenthol (2.2 g.) as fine white needles, m. p. 76—79° (recrystallised, m. p. 79°).

The viscous oil (7 g.) recovered from the petroleum mother-liquors was fractionally distilled through a small column packed with glass helices, fractions being taken at 2° intervals: (i) b. p. 109—111°/3 mm. (0.64 g.), (ii) b. p. 111—113°/3 mm. (1.07 g.), (iii) b. p. 113—115°/3 mm. (1.87 g.), (iv) b. p. 115—117°/3 mm. (0.82 g.), (v) b. p. 117—119°/3 mm. (0.91 g.), and (vi) b. p. 119—121°/3 mm. (0.22 g.). All six fractions were viscid oils and as no crystallisation occurred from light petroleum (b. p. 40—60°) they were esterified separately in pyridine with *p*-nitrobenzoyl chloride (1.6, 2.7, 4.7, 2.1, 2.3, and 0.6 g., respectively) for 3 days at room temperature. After being worked up in the usual way the esters crystallised from ethanol. Seven recrystallisations of the ester obtained from fraction (i) gave (±)-*trans*-2-hydroxyneomenthol di-*p*-nitrobenzoate (0.08 g.), m. p. 168°, and six recrystallisations of that from fraction (vi) gave (±)-*cis*-2-hydroxyisomenthol di-*p*-nitrobenzoate (0.1 g.), m. p. 138°, each identical with samples previously prepared. The esters from fractions (ii)—(v), after several recrystallisations, gave a mixture of two pale yellow crystalline forms: transparent monoclinic prisms, m. p. 135—138°, and opaque (cleavage planes) rods, m. p. 145—155°. The ester samples from the four fractions were therefore combined and slow, controlled crystallisation of the total material from ethanol (60 ml.) during 5 days gave large yellow transparent monoclinic prisms (2.85 g.), m. p. 138°, and pale yellow opaque rhombohedra (3.5 g.), m. p. 145—155°, which were separated by hand-picking. Spontaneous evaporation of the mother-liquor produced fine pale yellow needles (0.25 g.), m. p. 163—164°. Recrystallisation of the needles from ethanol gave (±)-*trans*-2-hydroxyisomenthol di-*p*-nitrobenzoate, m. p. and mixed m. p. 166°. The prisms were

substantially pure ( $\pm$ )-*cis*-2-hydroxyisomenthol di-*p*-nitrobenzoate, the m. p. not being raised by further recrystallisation. Recrystallisation of the rhombohedra several times from ethanol gave a pure ester, m. p. 165—166°, markedly depressed on admixture with all other known di-*p*-nitrobenzoates of comparable m. p. The compound is therefore considered to be ( $\pm$ )-*cis*-2-hydroxyneomenthol di-*p*-nitrobenzoate (Found : C, 61.4; H, 5.8; N, 6.0.  $C_{24}H_{26}O_6N_2$  requires C, 61.3; H, 5.5; N, 6.0%).

*Reduction of Diosphenol with Lithium Aluminium Hydride.*—(a) A solution of diosphenol (5 g.) in ether (50 ml.) was added dropwise with stirring to a suspension of lithium aluminium hydride (1 g.) in ether (25 ml.) at a rate just sufficient to maintain steady reflux. The mixture was then boiled under reflux for a further 3 hr. The excess of hydride was decomposed by water (50 ml.), the white precipitate thus produced being removed by washing with 5*N*-sulphuric acid (25 ml.). After washing of the ethereal solution with *N*-sodium hydroxide (10 ml.) and water (25 ml.) and drying ( $MgSO_4$ ) the solvent was removed. Fractionation of the residue gave colourless oils, b. p. 90—100°/5 mm. (2.5 g.) and 120—130°/5 mm. (0.7 g.). A residue of viscid yellow oil (1 g.) remained undistilled.

(b) Reduction of diosphenol (5 g.) as in (a) but with 2 g. of lithium aluminium hydride gave colourless oils, b. p. 90—98°/3 mm. (2.7 g.) and b. p. 114—115°/3 mm. (1.1 g.), and a residue (0.8 g.).

(c) A solution of diosphenol (5 g.) in benzene (25 ml.) was added slowly to a stirred suspension of lithium aluminium hydride (5 g.) in ether (25 ml.). The mixture was then heated for 3 hr. and worked up as before, giving colourless oils, b. p. 80—90°/2.5 mm. (1.1 g.) and b. p. 112—114°/2.5 mm. (2.3 g.). The still residue was negligible.

During several months the first fractions developed a very pale yellow colour and slowly deposited well-formed colourless prisms (1 g.), m. p. 159—163° (softening at 95°). The glycol fractions obtained from the reductions did not crystallise. Esterification of a small portion (0.5 g.) of the oil with *p*-nitrobenzoyl chloride (1.25 g.) in pyridine (25 ml.) gave a crude ester (oil) from which was obtained by repeated simple recrystallisation from relatively large volumes (30 ml.) of ethanol a small amount (50 mg.) of ( $\pm$ )-*trans*-2-hydroxyneomenthol di-*p*-nitrobenzoate, m. p. 168°. The crude glycol (1.6 g.), esterified with *p*-nitrobenzoyl chloride (4.0 g.) in pyridine (30 ml.) at room temperature for 4 days, gave an oil (5.0 g.). Fractional crystallisation of this from ethanol gave a small amount (0.1 g.) of ( $\pm$ )-*trans*-2-hydroxyneomenthol di-*p*-nitrobenzoate, m. p. 168°, and the *cis*-neoglycol di-*p*-nitrobenzoate, m. p. 165—166°.

The di-*p*-nitrobenzoate, m. p. 165—166° (1.5 g.), was hydrolysed for 2 hr. with potassium hydroxide (1.2 g.) in boiling methanol (15 ml.). After dilution with water (15 ml.) the methanol was removed by distillation. Next morning the glycol (60 mg.) which had crystallised as well-formed colourless flat rods, m. p. 35—45°, was filtered off. Continuous extraction (8 hr.) of the mother-liquor with ether yielded after drying ( $MgSO_4$ ) and removal of the ether an additional quantity (0.35 g.) of the same material. The glycol, considered to be ( $\pm$ )-*cis*-2-hydroxyneomenthol, obtained pure after four recrystallisations from light petroleum (b. p. <40°), had m. p. 52° (Found : C, 68.95; H, 11.7.  $C_{10}H_{20}O_2$  requires C, 69.75; H, 11.65%). Attempts to prepare a bis-3 : 5-dinitrobenzoate from the glycol failed.

( $\pm$ )-*cis*-2-Hydroxyisomenthol.—( $\pm$ )-*cis*-2-Hydroxyisomenthol di-*p*-nitrobenzoate (2.7 g.; m. p. 138°) was hydrolysed with potassium hydroxide (2 g.) in boiling methanol (25 ml.). After dilution with water (25 ml.) the methanol was removed by distillation and the product extracted continuously from the residue with light petroleum (b. p. 40—60°) for 4 hr. Evaporation of the solvent from the extract gave an oil (1.2 g.) which crystallised during 3 days. Three crystallisations from light petroleum (b. p. 40—60°) gave ( $\pm$ )-*cis*-2-hydroxyisomenthol (0.5 g.) as hard rosettes of fine colourless needles, m. p. 70.5—71°, which sublimed slowly at room temperature forming long fibres (Found : C, 70.0; H, 11.8%).

This glycol (0.1 g.) was boiled under reflux for 0.5 hr. with 3 : 5-dinitrobenzoyl chloride (0.3 g.) and pyridine (3 ml.) in benzene (15 ml.) and then set aside for 24 hr. Three recrystallisations of the crude ester from benzene-light petroleum (b. p. 40—60°) gave ( $\pm$ )-*cis*-2-hydroxyisomenthol bis-3 : 5-dinitrobenzoate as clusters of pale yellow needles, m. p. 143° (Found : C, 51.6; H, 4.6; N, 9.7.  $C_{24}H_{24}O_{12}N_4$  requires C, 51.4; H, 4.3; N, 10.0%).