

**902.** *Submicro-methods for the Analysis of Organic Compounds.*  
*Part II.\* The Determination of Alkoxy Groups.*

By R. BELCHER, M. K. BHATTY, and T. S. WEST.

Alkoxy groups can be determined on sample weights of the order of 50  $\mu\text{g}$ . by suitable modification of Zeisel's method. Several sources of error have been eliminated. The results obtained are generally within  $\pm 0.3\%$  absolute.

ZEISEL'S method<sup>1</sup> for determination of alkoxy groups appeared to be adaptable to the submicro-scale. Vieböck and Brecher's modification,<sup>2</sup> in which the determination is completed iodometrically, was the most attractive because of the six-fold amplification of the titre; hence, before the design of suitable apparatus was attempted, preliminary trials were made to ensure that the titration could be successful at this level. Suitable amounts of standard iodate solution and, later, of standard iodide solution after oxidation to iodate by bromine water, were titrated; satisfactory results were obtained.

The size of the conventional micro-scale apparatus was reduced and several modifications were introduced.<sup>3</sup> The final form is shown in the Figure. The water-condenser

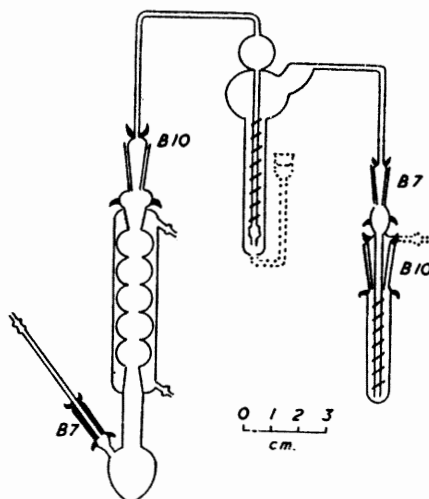

was shown to be essential. The main difficulty was the excessive "blank" values obtained on this scale of working; numerous details were studied, but these tests are not given, and it suffices to state that the following precautions must be taken: (1) The hydriodic acid must be prepared according to the instructions given later. (2) Nitrogen should be used as the carrier gas: carbon dioxide from the solid gave rise to high blanks owing to aerosol formation. (3) An efficient scrubber and scrubbing liquid must be used. The dimensions of the scrubber given in the Figure should be adhered to. The scrubbing liquid should be prepared fresh daily. (4) The rate of bubbling must be controlled carefully and should be about 1 bubble per second; a needle valve is essential for controlling the flow. (5) Irregular heating and draughts must be avoided. (6) Wherever rubber connections are used all the joints must be made glass-to-glass or metal-to-glass; if this precaution is not taken organic vapours in the atmosphere will penetrate the rubber and give rise to abnormal results. Aged rubber tubing must be used. (7) The apparatus must be kept clean; it

\* Part I, *J.*, 1957, 4323.

<sup>1</sup> Zeisel, *Monatsh.*, 1885, **6**, 989.

<sup>2</sup> Vieböck and Brecher, *Ber.*, 1930, **63**, 3207.

<sup>3</sup> Bhatti, Ph.D. Thesis, Birmingham University, 1957.

should be dried in an oven which is free from the vapour of organic solvents after each determination. The value of the blanks should not exceed 10  $\mu$ l. of 0.01N-sodium thio-sulphate.

The results obtained in the determination of alkoxy groups in ten organic compounds on sample weights of 45–60  $\mu$ g. are summarised in the Table. The accuracy of individual results generally lies within  $\pm 0.3\%$  of the absolute values. No extra precautions were necessary for the determination of ethoxy groups. The time required to complete all the operations involved in a single determination, including weighing, is approx. 2–2½ hr.

Compound	Alkoxy (%) *		No. of detmnts.	Max. error (absolute)	Min. error	$\Delta$ †
	CH <sub>3</sub> O	C <sub>2</sub> H <sub>5</sub> O				
$\alpha$ -Methyl-D-glucoside .....	16.00 (15.98)	—	9	-0.34	+0.04	0.20
Vanillin .....	20.49 (20.40)	—	11	+0.38	+0.03	0.16
Narcotine .....	22.58 (22.52)	—	9	-0.42	+0.03	0.23
Phenacetin .....	—	25.25 (25.15)	5	+0.30	-0.06	0.18
$\alpha$ -Methyl 2 : 3-O-dimethylglucoside ...	41.80 (41.89)	—	4	-0.37	+0.01	—
$\alpha$ -Methyl 2 : 3 : 4 : 6-O-tetramethyl-glucoside .....	52.47 (52.52)	—	2	-0.11	+0.01	—
3 : 4-Dimethylmannose monohydrate	27.53 (27.43)	—	3	+0.34	-0.04	—
<i>p</i> -Diethoxybenzene .....	—	54.31 (54.21)	3	+0.25	+0.04	—
<i>p</i> -Ethoxybenzoic acid .....	—	27.17 (27.11)	3	+0.19	+0.15	—
Methyl <i>p</i> -aminobenzoate .....	20.52 (20.51)	—	3	+0.17	-0.04	—

\* Calculated value in parentheses. † Standard deviation.

#### EXPERIMENTAL

*Reagents.*—(1) Hydriodic acid (*d* 1.7), "AnalaR" grade, purified according to Steyermark.<sup>4</sup> (2) Phenol, "AnalaR" grade. (3) Sodium antimonyl tartrate, 10% aqueous solution; freshly prepared every 1 or 2 days. (4) Sodium acetate, 10% solution in glacial acetic acid. (5) Sodium acetate, 25% aqueous solution. (6) Bromine, iodine free. (7) Formic acid (90%), "AnalaR" grade. (8) Sulphuric acid, 1N-solution. (9) Sodium thiosulphate, 0.01N-solution. (10) Potassium iodide, 10% solution freshly prepared daily. (11) "Thyodene" indicator.

*Apparatus.*—The following apparatus was used in addition to that given in the Figure: (1) An electrically heated aluminium block. (2) An "Agl" brand all-glass micrometer syringe burette. (3) A magnetic stirrer. (4) A "daylight" electric lamp to provide uniform illumination for titrations.

*Procedure.*—The absorber was charged with 1 ml. of sodium acetate-acetic acid solution and 4 drops of bromine were added from a capillary dropper. The scrubber was filled with 8 ml. of sodium antimonyl tartrate solution and its side arm was stoppered. The sample was weighed by difference into a platinum cup and transferred to the reaction flask by dropping the cup through the B7 side arm. A clean platinum tetrahedron, 0.25 g. of phenol, and 0.5 ml. of hydriodic acid were then added, and the B7 cone was placed in position, after the joint had been moistened with the acid. The joint between the scrubber and the absorber was lubricated with Silicone grease and all ground-glass joints were secured by metal springs. Water was circulated through the condenser and the nitrogen supply was connected to the apparatus through the B7 side arm attached to the digestion flask. The needle valve connecting the cylinder to the apparatus was adjusted so that nitrogen flowed through the apparatus at a rate corresponding to 1 bubble per second in the scrubber.

The contents of the flask were gradually raised to boiling during 30 min. and then digested at 220° for 60 min. (<40% alkoxy) or 90 min. (>40% alkoxy) as required.

The apparatus was disconnected and the contents of the absorber were quantitatively transferred to a titration beaker by using a transference pipette and four 1 ml. portions of water for washing. A magnetic stirring bar was used to mix the solution whilst 0.5 ml. of 25% sodium acetate solution was added and a sufficient number of drops (*ca.* 5) of formic acid to destroy the bromine. The contents of the beaker were stirred for 10 min. to ensure quantitative reduction of the free bromine, after which 5 drops of 1N-sulphuric acid and 3 drops of potassium iodide solution were added. The iodine thus liberated was titrated with 0.01N-sodium thio-sulphate; a microspatula-full of the Thyodene indicator was added immediately before the

<sup>4</sup> Steyermark, "Quantitative Organic Microanalysis," Blakeston Company, New York, p. 231 (1951).

end-point.\* A blank determination was carried out by a similar procedure without addition of sample. The original titre was corrected accordingly.

Factor: 1  $\mu$ l. of 0.01N- $\text{Na}_2\text{S}_2\text{O}_3$   $\equiv$  0.05172  $\mu$ g. of OMe  $\equiv$  0.0751  $\mu$ g. of OEt.

We are grateful to the D.S.I.R. and the Commonwealth Relations Office for the provision of research grants and to Mr. H. Cale for the construction of many pieces of glassware.

CHEMISTRY DEPARTMENT,  
THE UNIVERSITY, BIRMINGHAM, 15.

[Received, April 17th, 1957.]

\* It is important that the solution should remain cold during titration and it is therefore advisable to chill it. It is also important to carry out the titration slowly and smoothly.

---