

167. *Electrolytic Reduction of Some $\alpha\beta$ -Unsaturated Steroid Ketones.*

By PETER BLADON, J. W. CORNFORTH, and (MRS.) R. H. JAEGER.

Electrolytic reduction of cholest-4-en-3-one leads to the known "cholestenone pinacol," which is shown to be di-(3β -hydroxycholest-4-en- 3α -yl). Reduction of 7-oxocholest-5-en- 3β -yl acetate gives a thermally unstable pinacol, the stereochemistry of which is discussed; reduction of 20-oxopregna-5:16-dien- 3β -yl acetate gives a stereoisomeric mixture of disteroid diketones coupled at the 16-position.

IN extending work¹ on the antituberculosis effect of polyethylene ethers, we required compounds of molecular weight 600—1000, containing one or more reactive hydroxyl groups capable of polycondensation with ethylene oxide. Disteroids (compounds containing two linked steroid nuclei) seemed able to fulfil these and certain other requirements (*e.g.*, polycyclic rather than long-chain structure; ease of preparation), and this paper describes an exploration of several compounds of this class.

¹ Cornforth, D'Arcy-Hart, Nicholls, Rees, and Stock, *Nature*, 1951, **168**, 150; *Brit. J. Pharmacol.*, 1955, **10**, 73.

Windaus² reduced cholest-4-en-3-one with sodium amalgam in alcoholic acetic acid and obtained a high-melting product of high molecular weight. Butenandt and Poschmann,³ and Squire,⁴ later showed that it was the pinacol (I) derived from cholestenone. The configuration of the hydroxyl groups was not determined.

The preparation of cholestenone pinacol by Squire's method was inconvenient on a large scale, because of the large amounts of sodium amalgam needed. We turned to the electrolytic reduction of cholestenone with mercury as cathode and ethanolic sodium acetate as electrolyte. It was expected that the Kolbe reaction leading to ethane and carbon dioxide would take place at the carbon rod anodes, and so no diaphragm was used to separate the anodes from the cathode (cf. Swann⁵). Under controlled conditions satisfactory yields of the pinacol were obtained. Under acid conditions at higher temperatures di(cholesta-3 : 5-dien-3-yl) was formed (cf. the formation of a similar compound by polarographic reduction of cortisone⁶).

We next sought to introduce the necessary reactive hydroxyl groups *via* an intermediate epoxide. The pinacol (I) rapidly consumed 2 mols. of perbenzoic acid, giving the expected diepoxide (II). Both epoxide rings in this compound have the β -configuration, since treatment with lead tetra-acetate gave $4\beta : 5\beta$ -epoxycholestanone⁷ (III) in at least 64% yield.

An attempt to open the epoxide rings in (II) by treatment with aqueous perchloric acid in tetrahydrofuran yielded, not the expected hexahydric alcohol, but a compound (A) isomeric with the diepoxide. This is formulated as (IV) for the following reasons. Treatment with chromium trioxide in pyridine gave an amorphous diketone (B) (formulated as V), the infrared spectrum of which showed no absorption due to hydroxyl groups, and a single carbonyl peak at 1773 cm.^{-1} . Reduction of the ketone with lithium aluminium hydride regenerated the alcohol (A). Hence the hydroxyl groups in (A) must be secondary. The alternative structures (VI) and (VII) are excluded since carbonyl groups in 2-oxacyclobutanones are known^{8,9} to have absorption maxima at $1800\text{--}1820\text{ cm.}^{-1}$. On the other hand 3-oxacyclopentanones such as (V) have absorption maxima at lower frequencies^{9,10} (1748 and 1780 cm.^{-1}). The structure (IV), with ten fused rings, explains the remarkable insolubility and the thermal stability of the compound (A). It does not melt under 400° , and sublimes *in vacuo* at 350° . The hydroxyl groups in compound (A) are hindered: they could not be acetylated or toluene-*p*-sulphonylated in pyridine solution, nor could reaction with ethylene oxide be induced.

The isomerisation of cholestenone pinacol oxide (II) is envisaged as proceeding by the attack of the 3'-hydroxyl group on the rear (α) side of $C_{(5)}$, with simultaneous opening of the protonated $4\beta : 5\beta$ -epoxide ring, to form a 4β -hydroxyl group and a $3'\beta : 5\alpha$ -epoxide ring; similar events occur in both halves of the molecule. It follows that the hydroxyl groups in cholestenone pinacol oxide, and in the pinacol itself, must be β -oriented; neither of the other arrangements ($\alpha\alpha'$; $\alpha\beta'$) permits the formation of a compound with the properties of (IV). The pinacol derived from androst-4-en-3-one¹¹ presumably has a similar structure.

Similar electrolytic reduction was applied to 7-oxocholesteryl acetate. The crude product was chromatographed, three principal fractions being obtained: a mixture of 7-oxocholesteryl and 7-oxocholestanyl acetate; a solid (D), formulated as the pinacol (VIII);

² Windaus, *Ber.*, 1906, **39**, 521.

³ Butenandt and Poschmann, *Ber.*, 1940, **73**, 893.

⁴ Squire, *J. Amer. Chem. Soc.*, 1951, **73**, 2587.

⁵ Swann, "Electrolytic Reactions," in "Technique of Organic Chemistry," ed. Weissberger, Interscience Publ. Inc., New York, 1948, Vol. II, p. 152.

⁶ Kabasakallian and McGlotten, *J. Amer. Chem. Soc.*, 1956, **78**, 5032.

⁷ Plattner, Heusser, and Kulkarni, *Helv. Chim. Acta*, 1948, **31**, 1822.

⁸ Muir, Hoey, and Lester, *J. Amer. Chem. Soc.*, 1955, **77**, 4430.

⁹ Hirschmann, Bailey, Poos, Walker, and Chernerda, *ibid.*, 1956, **78**, 4814.

¹⁰ Allen and Bernstein, *ibid.*, p. 3223.

¹¹ Butenandt, Poschmann, Failer, Schiedt, and Biekert, *Annalen*, 1951, **575**, 123.

and a monomeric steroid, formulated as 3β -acetoxy- 5ζ -hydroxycholestan-7-one (IX) since alkaline hydrolysis converted it into cholesta-3 : 5-dien-7-one.

The solid (D) was undoubtedly a pinacol, for it was cleaved smoothly by lead tetraacetate to 7-oxocholesteryl acetate in 75% yield. The low melting point (149°) and low results in the Rast molecular-weight determination were puzzling until it was recognised

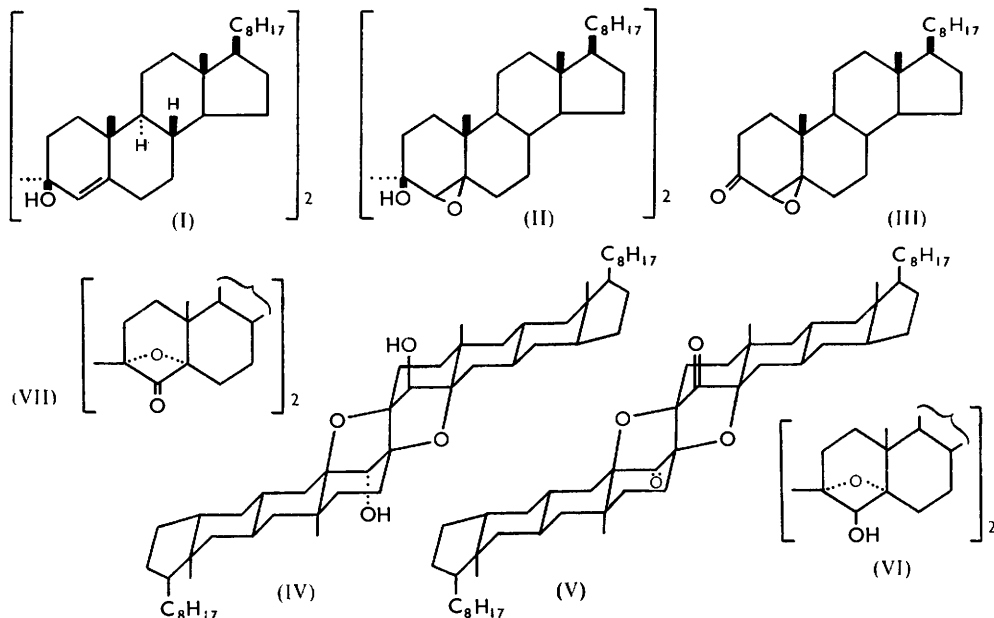

that the compound was decomposed on melting to an equimolecular mixture of 7-oxocholesteryl and 7-oxocholestanyl acetate. The melting point of the pinacol is in fact the melting point of the mixture, and the infrared and ultraviolet spectra of the melt were as expected. Both components were isolated from the cooled melt by chromatography over alumina.

The pinacol (D) reacted rapidly with 1 mol. of perbenzoic acid, to give as the main product a monoepoxide. Further reaction was much slower and led to a compound which was presumably the diepoxide. Both products had high melting points, and the molecular weight found for the monoepoxide was in the range expected for a dimeric steroid.

Three structures are theoretically possible for the pinacol; in these, the tertiary hydroxyl groups are respectively $7\alpha : 7'\alpha$, $7\beta : 7'\beta$, and $7\alpha : 7'\beta$. Only the 7α -OH : $7'\alpha$ -OH structure can be made on molecular (Catalin) models without severe distortion caused by interference between the two steroid nuclei, and rotation about the $7 : 7'$ bond does not seem possible with any structure. The simplest explanation of the perbenzoic acid oxidation is that the two double bonds are non-equivalent; this is only true of the 7α -OH : $7'\beta$ -OH structure. Moreover, this structure allows a plausible explanation of the fission on pyrolysis, which can be seen as a concerted reaction with a cyclic transition state (X \rightarrow XI) of a type which has been postulated in the thermal decomposition of β -oxo-acids¹² and $\beta\gamma$ -unsaturated acids¹³ and in the pyrolysis of certain esters yielding olefins.¹⁴ The relative thermal stability of the monoepoxide can then be understood if the $5 : 6$ -double bond participating in this transition state is the first to be oxidised (XII).

¹² Westheimer and Jones, *J. Amer. Chem. Soc.*, 1941, **63**, 3283.

¹³ Arnold, Elmer, and Dodson, *ibid.*, 1950, **72**, 4359; Barton and Brooks, *J.*, 1951, 257.

¹⁴ Cram, "Olefin Forming Elimination Reactions," in "Steric Effects in Organic Chemistry," ed. Newman, Wiley, New York, 1956, p. 305.

However, reluctance to form a diepoxide does not necessarily mean non-equivalence of the two double bonds in such crowded structures as these pinacols. Three steric factors might operate against introduction of a second oxygen atom: (i) the first oxygen atom directly obstructs introduction of the second, (ii) the change in conformation at position 7, consequent upon the first epoxidation, increases steric shielding of the second double bond, (iii) the second epoxidation is resisted because the resulting change in conformation would

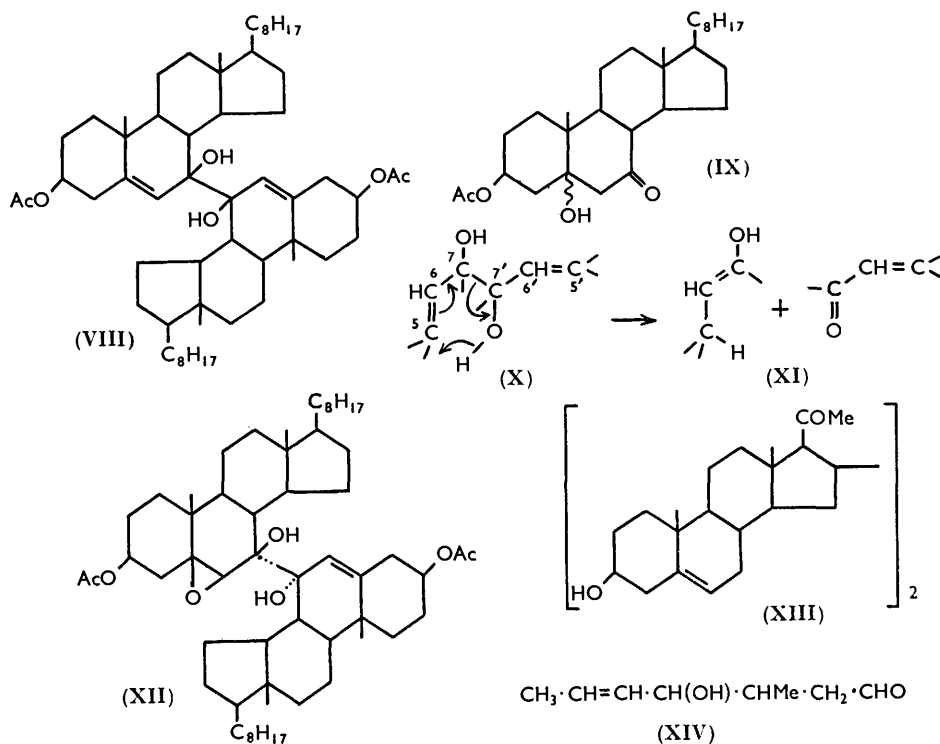

cause excessive steric compression. Though it is hard to assess the relative importance of such factors, they suggest that the symmetrical $7\alpha\text{-OH} : 7'\alpha\text{-OH}$ structure, which is the least strained of the three, cannot be excluded by the evidence of perbenzoic acid oxidation. The thermal fission need not, of course, be an intramolecular process, as in $(\text{X} \rightarrow \text{XI})$; the strained $7 : 7'$ -bond might suffer a heterolysis which would be facilitated by both double bonds. The stereochemistry of this pinacol at positions 7 and 7' remains undetermined.

Attempts to obtain a pinacol by electrolytic reduction of 3β -acetoxypregna-5 : 16-dien-20-one, in the apparatus used with cholestenone and 7-oxocholesteryl acetate, failed to yield a crystalline product. Accordingly the process was modified. The cell consisted of a mercury cathod of limited area (4 cm.^2), a carbon rod anode, and an electrolyte of sodium acetate in methanolic acetic acid. The concentration of the steroid was higher than in the previous experiments, and the solution was allowed to reflux. The crude product afforded a solid, some of which had separated during the electrolysis. It was found to be a mixture which could not be separated into pure components by chromatography or crystallisation. The absence of a hydroxyl absorption band in its infrared spectrum showed that it did not contain a pinacol, and the peaks in the carbonyl region indicated that both ketone and acetate groups were present.

The corresponding mixture of alcohols obtained on saponification was separated into

two pure components by crystallisation. These were characterised as acetates and benzoates, and are regarded as two isomeric forms of di-(3 β -hydroxy-20-oxopregn-5-en-16-yl) (XIII). They are referred to as "isomer I" and "isomer II". There appears to be no stereochemical reason why a pinacol should not have been formed in this reduction, and the coupling at the 16-position must be attributed to its high reactivity compared with that of the 5-position in cholestenone and 7-oxocholesteryl acetate.

Bands in the infrared spectra of the acetate (and benzoate) of isomer II in the region of 3500 cm^{-1} are ascribed to overtone absorption of the carbonyl groups rather than to hydroxyl groups, since they remained unchanged when the substance was recrystallised from dioxan-deuterium oxide.¹⁵ The possibility of the presence of the type of structure analogous to (XIV), which is obtained by the reduction of crotonaldehyde with sodium amalgam,¹⁶ is thereby eliminated.

After completion of this work, Lund¹⁷ reported experiments on the controlled electrolytic reduction of some unsaturated steroid ketones, including cholestenone, testosterone, progesterone, androstenedione, and 17 β -hydroxyandrost-1:4-dien-3-one. From the last-named substance two different pinacols were obtained, one (X) by reduction at pH 5 and the other (Y) by reduction at pH 12.5. It was suggested, on grounds which merit criticism, that the tertiary hydroxyl groups are α in X and β in Y. The steroid is presumed to approach with its α -face to the cathode. If the carbonyl oxygen is protonated, it is attracted to the cathode, and when an electron is added the product is an allylic radical having an α -hydroxyl group; in alkaline solution the carbonyl-oxygen atom is repelled from the cathode and leads to a radical having a β -hydroxyl group. These radicals are assumed to retain these configurations until they dimerise by a slow reaction. Such retention of configuration appears improbable. Another argument is based on the greater ease of dehydration of one isomeride; this argument gratuitously assumes an initial S_N2' rearrangement. In a third argument based on optical rotation, differences in *molecular* rotation of reference substances, which are not 1:4-dien-3-ols, are compared with the difference in *specific* rotation between the pinacols. It seems to us that configurations cannot yet be confidently assigned to these two isomerides. Configurations for the other pinacols were not suggested.

EXPERIMENTAL

Unless otherwise indicated, m. p.s were determined in evacuated capillaries; on a Kofler block [m. p.s marked (K)] the less fusible compounds melted neither sharply nor reproducibly. Optical rotations were determined for CHCl_3 solutions, ultraviolet spectra were determined for EtOH solutions (unless stated otherwise). Deactivated alumina was prepared by shaking alumina (Peter Spence, Type H) in light petroleum with 10% aqueous acetic acid (5 c.c. per 100 g.). Extracts were normally dried over anhydrous sodium sulphate.

Di-(3 β -dihydroxycholest-4-en-3 α -yl) (I).—(a) Reduction of cholestenone with sodium amalgam by Squire's method⁴ gave the pinacol in 45% yield as needles (from benzene-acetone), m. p. 225–227°, $[\alpha]_D +92^\circ$ (*c* 1.05). Squire records m. p. 200–205°, $[\alpha]_D +110^\circ$; Butenandt records³ m. p. 200°, $[\alpha]_D +103^\circ$. (b) *Electrolytic reduction of cholestenone*. The apparatus shown in Fig. 1 was employed. In the 1 l. beaker were placed sodium acetate trihydrate (20 g.), cholest-4-en-3-one (12 g.), ethanol (750 c.c.), and mercury (900 g.). The mixture was electrolysed for 1 hr. A potential between 160 and 190 v was needed to maintain a current of approximately 3 amps. The temperature was kept between 20° and 30° by addition of solid carbon dioxide to the acetone bath surrounding the beaker, and by adjustments of the current. The end of the reduction was marked by the sharp increase of the resistance of the cell (due to the withdrawal of sodium ions as sodium hydrogen

¹⁵ Jones and Sandorfy, "The Application of Infrared and Raman Spectrometry to the Elucidation of Molecular Structure," in "Technique of Organic Chemistry," ed. Weissberger, Interscience Publ. Inc., New York, 1956, Vol. IX, p. 425.

¹⁶ Nahum, *Compt. rend.*, 1956, **243**, 849.

¹⁷ Lund, *Acta Chem. Scand.*, 1957, **11**, 283.

carbonate which is precipitated). The reaction mixture was poured into water (1.5 l.), and the solid coagulated by stirring, collected, roughly dried, and dissolved in benzene. Any water present was separated or removed with sodium sulphate. The solution was filtered (to remove traces of mercury) and concentrated. Addition of acetone yielded di-(3 β -hydroxy-cholest-4-en-3 α -yl) as needles (5.1—6.1 g., 42—51%), m. p. 227—230°, $[\alpha]_D +91^\circ$ (*c* 0.84), $\nu_{\max.}$ (KCl) 3320 (OH), 1665 cm^{-1} (—CH=C—).

Electrolytic reduction of cholestenone (4 g.) in propan-1-ol (150 c.c.) and glacial acetic acid (150 c.c.) containing sodium acetate trihydrate (15 g.) for 3 hr. at 60—70° (ice-cooling), gave di(cholesta-3 : 5-dien-3-yl) (40%), as pale yellow crystals (from chloroform), m. p. 365—370° (decomp.), $[\alpha]_D -193^\circ$ (*c* 0.129) (Found: C, 88.2; H, 11.5. Calc. for $\text{C}_{54}\text{H}_{86}$: C, 88.2; H, 11.8%). $\lambda_{\max.}$ (in CHCl_3) 298, 311, and 326 $\text{m}\mu$ (ϵ 32,000, 41,540, 30,000). Squire⁴ records m. p. 243—247°, $[\alpha]_D -260^\circ$, $\lambda_{\max.}$ (in CHCl_3) 298, 312, and 323 $\text{m}\mu$ (ϵ 48,000, 63,100, 47,000).

Di-(3 β -hydroxy-4 β : 5 β -epoxycholestan-3 α -yl) (II).—Cholestenone pinacol (I) (8 g.) in chloroform (140 c.c.) was treated with 0.45M-perbenzoic acid in benzene (45 c.c., 2.4 mols.), and kept overnight at room temperature. Water and aqueous potassium hydrogen carbonate were added, and the chloroform layer was separated, washed with water, dried, and evaporated to

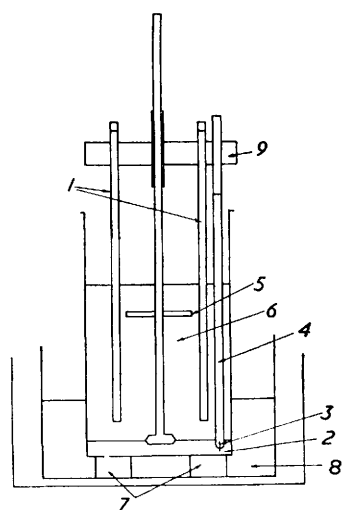

FIG. 1.

- 1, Carbon rod anodes (four).
- 2, Mercury cathode.
- 3, Platinum wire connection.
- 4, Mercury connection.
- 5, Stirrer.
- 6, Electrolyte.
- 7, Cork spacers.
- 8, Acetone-solid carbon dioxide freezing mixture.
- 9, Cork support for electrodes and stirrer.

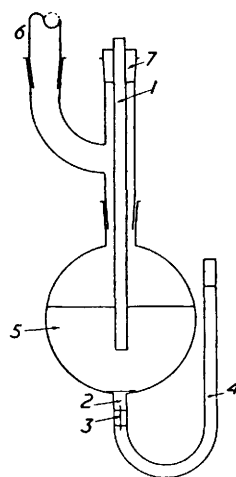

FIG. 2.

- 1, Carbon rod anode.
- 2, Mercury cathode.
- 3, Platinum wire connection.
- 4, Mercury connection.
- 5, Electrolyte.
- 6, Reflux condenser.
- 7, Rubber stopper.

small bulk. Addition of acetone yielded crystals, m. p. 315° (7.9 g.). Recrystallisation of a portion from chloroform-acetone gave needles of *di*-(3 β -hydroxy-4 β : 5 β -epoxycholestan-3 α -yl), m. p. 315°, $[\alpha]_D +0.2^\circ$ (*c* 0.83) (Found: C, 81.1; H, 11.1. $\text{C}_{54}\text{H}_{90}\text{O}_4$ requires C, 80.7; H, 11.2%). $\nu_{\max.}$ (in KCl) 3500 cm^{-1} (OH).

With excess of perbenzoic acid the first 2 mols. were consumed rapidly (15 min.), and then a further slow uptake occurred during 24 hr., approaching 6 mols. Material isolated after this time had m. p. 305°, $[\alpha]_D +0.2^\circ$ (*c* 1.16) (Found: C, 79.7; H, 11.2%). It gave a good yield of pure product in the rearrangement reaction (see below).

Treatment of Cholestenone Pinacol Diepoxide with Lead Tetra-acetate.—The diepoxide (500 mg.) in dry benzene (10 c.c.) was treated with lead tetra-acetate (600 mg.) in dry benzene (25 c.c.) and set aside for 1 hr. Ethylene glycol (2 c.c.) was added, followed by dilute acetic acid. The product was isolated by ether-extraction, and the extracts were washed with water and dried. Evaporation of the extracts gave an oil (494 mg.) which solidified with methanol. Two recrystallisations from acetone-methanol gave 4 β : 5 β -epoxycholestan-3-one (III) (321 mg.), as needles, m. p. 119—121° (K), $[\alpha]_D +131^\circ$ (*c* 1.01) (Found: C, 81.1; H, 11.2. Calc. for $\text{C}_{27}\text{H}_{44}\text{O}_2$: C, 80.95; H, 11.1%). The infrared spectrum was identical with that of an authentic specimen prepared by the method of Plattner *et al.*,⁷ and the m. p. of the mixture of material from both sources was not depressed.

Di-(3 β : 5' α -epoxy-4 β -hydroxycholestan-3 α -yl) (IV).—Cholestenone pinacol diepoxide (4 g.) in tetrahydrofuran (200 c.c.) was treated with 60% aqueous perchloric acid (10 c.c.) and kept

overnight at room temperature. Addition of water precipitated a solid, which was collected, washed with water, resuspended in water containing sodium hydroxide, collected, washed with water, and dried *in vacuo* (yield 4 g.; m. p. $>390^\circ$). Recrystallisation from tetrahydrofuran-acetone afforded pure *di*-(3β : $5'\alpha$ -epoxy- 4β -hydroxycholestan- 3α -yl), m. p. $>400^\circ$, $[\alpha]_D +16.7^\circ$ (*c* 1.55 in pyridine) (Found: C, 80.7; H, 11.0. $C_{54}H_{96}O_4$ requires C, 80.7; H, 11.2%), ν_{\max} . (in KCl) 3590 and 3450 cm^{-1} (OH). This compound sublimes unchanged at $340^\circ/10^{-5}$ mm.

Di-(3β : $5'\alpha$ -epoxy- 4 -oxocholestan- 3α -yl) (V).—*Di*-(3β : $5'\alpha$ -epoxy- 4β -hydroxycholestan- 3α -yl) (500 mg.) in pyridine (35 c.c.) was added to a solution of chromium trioxide (2.0 g.) in pyridine (50 c.c.). Next day, excess of dilute hydrochloric acid was added, followed by solid sodium sulphite. After 1 hour's stirring the precipitated solid was collected and dried *in vacuo*. The light grey amorphous solid, m. p. 330° , $[\alpha]_D -91.7^\circ$ (*c* 1.25), did not crystallise from the usual solvents. A hot solution in dimethylformamide formed a stiff gel on cooling. A sample purified by pouring a boiling solution in dimethylformamide into boiling water became granular on drying. The *diepoxide* had $[\alpha]_D -90.4^\circ$ (*c* 0.90) (Found: C, 81.4; H, 10.65. $C_{54}H_{86}O_4$ requires C, 81.2; H, 10.85%), ν_{\max} . (in CHCl_3) 1773 cm^{-1} (C=O), no hydroxyl band.

The ketone (V) (250 mg.) in tetrahydrofuran (25 c.c.) was refluxed with lithium aluminium hydride (500 mg.) for 4 hr. Decomposition of excess of reagent with acetone, followed by hydrochloric acid, precipitated a white solid (237 mg.). This was dissolved in tetrahydrofuran and the solution filtered through kieselguhr and evaporated to small bulk. Addition of acetone precipitated *di*-(3β : $5'\alpha$ -epoxy- 4β -hydroxycholestan- 3α -yl) (167 mg.), m. p. $>380^\circ$, having an infrared spectrum identical with that of authentic material.

Electrolytic Reduction of 7-Oxocholesteryl Acetate.—The apparatus was similar to that used for the electrolysis of cholestenone. 7-Oxocholesteryl acetate (6 g.) and sodium acetate trihydrate (15 g.) in ethanol (600 c.c.) were electrolysed for 3 hr. A potential of 140 v resulted in a current of 4 amp. when the temperature was kept at 40° . Acetic acid (25 c.c.) was added during the reduction, completion of which was marked by a drop in current. The reaction mixture was poured into water (2000 c.c.) and the precipitated solid collected, washed with water, and roughly dried *in vacuo*. It was dissolved in dichloromethane; the solution was dried and evaporated. The residue was dissolved in 4 : 1 light petroleum-benzene and chromatographed on deactivated alumina (600 g.). Fractions of 110 c.c. were collected and evaporated. Fractions 1—15 (4 : 1 to 1 : 1 light petroleum-benzene) yielded oils (0.293 g.). Fractions 16—69 (1 : 1 light petroleum-benzene to benzene) yielded crystals (C) (3.688 g.). Fractions 70—79 (9 : 1 benzene-ether) gave a solid (D) (1.232 g.). Fractions 80—88 (9 : 1 benzene-ether to ether) yielded oils (0.149 g.). Fractions 89—109 (ether) yielded solid (E) (0.485 g.). Finally elution with 9 : 1 ether-methanol (fractions 110—119) gave only oily material.

The solid (C) had the characteristics of a mixture of 7-oxocholesteryl and 7-oxocholestanyl acetate.

Solid (D), recrystallised from dichloromethane-acetone, had m. p. 146 — 149° (K) (640 mg.). Further recrystallisation afforded pure 3β -acetoxy-7-(3β -acetoxy-7-hydroxycholest-5-en-7-yl)-cholest-5-en-7-ol (7-oxocholesteryl acetate pinacol) (VIII), m. p. 149 — 152° (K), $[\alpha]_D -57.8^\circ$ (*c* 1.05) (Found: C, 78.7, 78.4; H, 10.8, 10.5%; *M*, 343, 360. $C_{58}H_{94}O_6$ requires C, 78.5; H, 10.7%; *M*, 887), ν_{\max} . (in KCl) 3510 and 3420 (OH), 1730 and 1240 cm^{-1} (OAc), ν_{\max} . (in CHCl_3) 3510 (OH), 1724 cm^{-1} (OAc). A sample recrystallised from tetrahydrofuran by addition of deuterium oxide (99.2%) had ν_{\max} . (in CHCl_3) 3510 (OH), 2654 (OD), and 1724 cm^{-1} (OAc).

Solid (E) recrystallised from dichloromethane-ether gave 3-acetoxy- 5ξ -hydroxycholestan-7-one (IX) (135 mg.), m. p. 225 — 226° (K), $[\alpha]_D -44^\circ$ (*c* 0.60) (Found: C, 75.6, 75.4; H, 10.7, 10.5; *M*, 474. $C_{29}H_{46}O_4$ requires C, 75.6; H, 10.5%; *M*, 460), ν_{\max} . (in KCl) 3360 (OH), 1728 and 1250 (OAc), and 1703 cm^{-1} (C=O).

Treatment of 7-Oxocholesteryl Acetate Pinacol with Lead Tetra-acetate.—The pinacol (200 mg.) in dry benzene (6 c.c.) was treated with lead tetra-acetate (300 mg.) in dry benzene (10 c.c.). Immediate precipitation of lead diacetate occurred. After 1 hr. ethylene glycol (1 c.c.) was added and, after a further 0.5 hr. of intermittent shaking, the product was isolated by addition of dilute acetic acid and extraction with ether. Evaporation of the dried extracts yielded a solid residue (197 mg.). Crystallisation from acetone-methanol gave platelets of 7-oxocholesteryl acetate (151 mg.), m. p. and mixed m. p. 159 — 161° (K) (with a change of crystalline form at 147 — 150° ; sometimes with melting and resolidifying), $[\alpha]_D -101^\circ$ (*c* 1.30). This material had an infrared spectrum identical with that of authentic material.

Thermal Decomposition of 7-Oxocholesteryl Acetate Pinacol.—Small samples of the pinacol

after melting and cooling showed λ_{\max} . 235 $m\mu$ (ϵ 6455), ν_{\max} . (in CCl_4) 1735, 1707, 1675, and 1631 cm^{-1} .

The pinacol (200 mg.) was heated at 160—170° for 5 min. in nitrogen. The product solidified on cooling and was chromatographed in light petroleum on deactivated alumina (100 g.). Elution with light petroleum—benzene (3 : 2 to 1 : 1) (450 c.c.) gave traces of oily material. Elution with mixtures containing more benzene (1 : 1 to 1 : 4) and finally pure benzene (450 c.c.) gave 5 solid fractions. The first of these (46 mg.), plates, m. p. 144—150° (K), had ν_{\max} . (in CCl_4) 1731, 1708 cm^{-1} .

Recrystallisation from methanol gave 7-oxocholestanyl acetate (29 mg.) as plates, m. p. and mixed m. p. 150—152° (K), $[\alpha]_D -39.5^\circ$ (c 0.57), ν_{\max} . (in KCl) 1725 (OAc), 1700 cm^{-1} (C=O). An authentic specimen prepared by hydrogenation of 7-oxocholesteryl acetate (Wintersteiner and Moore¹⁸) had m. p. 149—151° (K), $[\alpha]_D -35.5^\circ$ (c 1.25), and an identical infrared spectrum. The last two fractions (total 45 mg.) formed prisms, m. p. 158—163° (K) (change of form at 150°), and had ν_{\max} . (in CCl_4) 1732, 1675, and 1630 cm^{-1} . Recrystallisation from acetone—methanol gave prisms of 7-oxocholesteryl acetate (31 mg.), m. p. and mixed m. p. 161—163° (K) (with a change of form at 149—152°), $[\alpha]_D -103^\circ$ (c 0.61), ν_{\max} . (in KCl) 1727 (OAc), 1667 and 1630 cm^{-1} (C=CH—C=O). Authentic material had m. p. 158—160° (K), $[\alpha]_D -99^\circ$ (c 1.29), λ_{\max} . 225 $m\mu$ (ϵ 12,170) and an identical infrared spectrum. The two intermediate fractions had infrared spectra similar to that of the mixture before chromatography, so were mixtures of 7-oxocholesteryl and 7-oxocholestanyl acetate. The total amount eluted from the column was 199 mg.

Treatment of 7-Oxocholesteryl Acetate Pinacol with Perbenzoic Acid.—The pinacol in dichloromethane, treated with excess of perbenzoic acid in benzene, consumed 1 mol. within 15 min. Thereafter, reaction was slower and after 24 hr. 1.7 mol. had been consumed. The product (m. p. 265—277°) isolated at this stage was identical with the second material described below.

To the pinacol (250 mg.) in dichloromethane (5 c.c.) was added 0.44M-perbenzoic acid (0.71 c.c., 1.1 mol.), and the mixture was kept until only a trace of per-acid was left (3 hr.). The product was isolated by adding ether and washing the whole with dilute potassium hydroxide solution. Evaporation of the dried ethereal phase yielded an oil (268 mg.) which rapidly solidified. Recrystallisation from dichloromethane—acetone afforded needles of the *monoepoxide* (XII), m. p. 230—233°, $[\alpha]_D -34.9^\circ$ (c 1.10) (Found: C, 76.9; H, 10.5%; M , 708. $\text{C}_{58}\text{H}_{94}\text{O}_7$ requires C, 77.1; H, 10.5%; M , 902), ν_{\max} . (in KCl) 3520 and 3420 (OH), 1735 and 1243 cm^{-1} (OAc).

When the pinacol (500 mg.) in dichloromethane (5 c.c.) was kept with 0.44M-perbenzoic acid (1.409 c.c., 1.1 mol.) for 24 hr., the crude product (525 mg.), treated with ether, yielded crystals, m. p. 250—270° (51 mg.). Recrystallisation from dichloromethane—acetone afforded a *diepoxide*, m. p. 265—277° (decomp.), $[\alpha]_D -24.7^\circ$ (c 0.41) (Found: C, 75.5; H, 10.3. $\text{C}_{55}\text{H}_{94}\text{O}_8$ requires C, 75.8; H, 10.3%), ν_{\max} . (in KCl) 3410 (OH), 1730, and 1245 cm^{-1} (OAc.) The ethereal mother-liquors, on concentration and addition of acetone, gave needles, m. p. 235—237° (122 mg.). Recrystallisation from dichloromethane—acetone gave the monoepoxide as needles, m. p. 229—231°, $[\alpha]_D -35.2^\circ$ (c 0.89) (Found: C, 77.2; H, 10.5%), whose infrared spectrum was identical with that of the material described above.

Alkali Treatment of 3 β -Acetoxy-5 ξ -hydroxycholestan-7-one.—The ketone (45 mg.) was refluxed with 50% w/v aqueous potassium hydroxide (1 c.c.) in tetrahydrofuran (1 c.c.) and methanol (6 c.c.) for 1 hr. Working up with water and ether and chromatography of the crude oil (43 mg.) on deactivated alumina (4 g.) yielded a solid (35 mg.). Crystallisation from methanol gave cholesta-3 : 5-dien-7-one, m. p. 110—113° (K), identical with a specimen prepared by alkaline hydrolysis of 7-oxocholesteryl acetate.

Electrolytic Reduction of 3 β -Acetoxypregna-5 : 16-dien-20-one.—The apparatus is shown in Fig. 2. In the flask were placed the mercury cathode (5 c.c.), methanol (300 c.c.), acetic acid (7.5 c.c.), and sodium acetate trihydrate (7.5 g.). The electrolysis was started, and when the contents of the flask had begun to boil, 3 β -acetoxypregna-5 : 16-dien-20-one (15 g.) and methanol (50 c.c.) were added. The electrolysis was resumed, whereupon the steroid rapidly dissolved. A potential of 220 v across the cell produced a current of about 1 amp. The current was unsteady because of the boiling of the solution at the mercury surface. After about 4 hr. when 3.5 ampère-hours had passed through the cell, the contents were added to water, and the

¹⁸ Wintersteiner and Moore, *J. Amer. Chem. Soc.*, 1943, **65**, 1503.

precipitated material isolated by extraction with ether and dichloromethane in the usual way. Evaporation of the extracts left a syrup which was treated with methanol to give a solid (4.7–5.4 g.), m. p. 260–290°. The combined solid products (13.8 g.) from several experiments (39 g. of starting material) were recrystallised once from dichloromethane–acetone, to yield a solid (F) (9.64 g.), m. p. 270–280°, $[\alpha]_D -16.7^\circ$ (*c* 0.92), ν_{\max} . (in Nujol) 1735 and 1242 (OAc), 1709 cm^{-1} (C=O), no hydroxyl peak. From the mother-liquors a second crop (G) was obtained (2.1 g.), m. p. 250–300°.

Saponification of the solid (G). The solid (G) (2.1 g.) in 2-methoxyethanol (70 c.c.) was refluxed with 50% w/v aqueous potassium hydroxide solution for 1.5 hr. The mixture was poured into water and acidified with dilute hydrochloric acid. The precipitated solid was filtered off and dried (1.73 g.). One recrystallisation from methanol gave crystals (1.2 g.), m. p. 304–316°. Recrystallisation from 2-methoxyethanol gave needles of *di*-(3 β -hydroxy-20-oxopregn-5-en-16-yl), isomer I (XIII), m. p. 325–329°, $[\alpha]_D -80.8^\circ$ (*c* 0.86) (Found: C, 79.6; H, 9.95. $\text{C}_{42}\text{H}_{62}\text{O}_4$ requires C, 79.95; H, 9.9%), ν_{\max} . (in Nujol) 3431 (OH), 1690 cm^{-1} (C=O). Acetylation with acetic anhydride and pyridine at room temperature gave *di*-(3 β -acetoxy-20-oxopregn-5-en-16-yl), isomer I, needles (from dichloromethane–acetone), double m. p. 293–296° and 302–303°, $[\alpha]_D -80^\circ$ (*c* 0.63) (Found: C, 77.6; H, 9.6. $\text{C}_{46}\text{H}_{66}\text{O}_6$ requires C, 77.3; H, 9.3%), ν_{\max} . (in Nujol) 1724 and 1242 (OAc), 1706 cm^{-1} (C=O). Benzoylation with benzoyl chloride and pyridine gave *di*-(3 β -benzoyloxy-20-oxopregn-5-en-16-yl), isomer I, m. p. 352–355° (decomp.) (from dichloromethane), $[\alpha]_D -30.4^\circ$ (*c* 0.69) (Found: C, 80.2; H, 8.7. $\text{C}_{56}\text{H}_{70}\text{O}_6$ requires C, 80.1; H, 8.4%). ν_{\max} . (in Nujol) 1718 (C=O and OBz), 1289 and 1277 cm^{-1} (OBz).

Saponification of solid (F). The solid (F) (6.0 g.) in 2-methoxyethanol (150 c.c.) was refluxed for 2 hr. with potassium hydroxide (10 g.) in water (15 c.c.). The mixture was poured into water and acidified with dilute hydrochloric acid. The solid product was collected and dried *in vacuo*. The solid was dissolved in boiling 2-methoxyethanol, which was concentrated after filtration to small bulk (125 c.c.) and cooled. The first crop of crystals was collected, washed with ether, and dried, to give *di*-(3 β -hydroxy-20-oxopregn-5-en-16-yl), isomer I (933 mg.), m. p. 320–325°, $[\alpha]_D -79^\circ$ (*c* 0.75). The infrared spectrum was identical with that of the material described earlier.

The mother-liquors were concentrated to small bulk (25 c.c.), giving a second crop (900 mg.), m. p. 255–260° (sintering at 200–220°), which was washed with methanol. Boiling of the methanolic filtrates caused the separation of a third crop, as needles (1715 mg.), m. p. 268–270° (sintering at 193–200°). This gave on recrystallisation from 2-methoxyethanol, *di*-(3 β -hydroxy-20-oxo-pregn-5-en-16-yl), isomer II (XIII), m. p. 269–271°, $[\alpha]_D -9.0^\circ$ (*c* 0.69), -8.20° (*c* 0.76), -8.2° (*c* 1.24) (three separate preparations) (Found: C, 77.95, 77.9; H, 10.3, 9.9%; *M*, 698. $\text{C}_{42}\text{H}_{62}\text{O}_4, \text{H}_2\text{O}$ requires C, 77.7; H, 9.9%; *M*, 649) (the water of crystallisation was not given up on drying at 130°/0.01 mm.), ν_{\max} . (in Nujol) 3390 (OH), 1705 cm^{-1} (C=O). The *diacetate*, isomer II, prepared in the usual way and crystallised from dichloromethane–methanol, had m. p. 287–290° (depressed on admixture with the diacetate, isomer I), $[\alpha]_D -22.4^\circ$ (*c* 1.15) (Found: C, 77.0; H, 9.5%; *M*, 623. $\text{C}_{46}\text{H}_{66}\text{O}_6$ requires C, 77.3; H, 9.3%; *M*, 715), ν_{\max} . (in Nujol) 3262 (C=O overtone), 1740 and 1242 (OAc), and 1713 cm^{-1} (C=O), ν_{\max} . (in CHCl_3) 3509 (C=O overtone), 1739 (OAc), and 1709 cm^{-1} (C=O). The infrared spectrum in chloroform was not changed by recrystallisation of the solid from dioxan–deuterium oxide (99.2%). The *dibenzoate*, isomer II, prepared in the usual way and crystallised from dichloromethane–acetone, had m. p. 346–348° (decomp.), $[\alpha]_D +18.6^\circ$ (*c* 0.74) (Found: C, 80.0; H, 8.6. $\text{C}_{56}\text{H}_{70}\text{O}_6$ requires C, 80.1; H, 8.4%), ν_{\max} . (in Nujol) 3335 (C=O overtone), 1715 (C=O and OBz), 1279 cm^{-1} (OBz).

We acknowledge with thanks a generous gift of dehydropregnenolone acetate from Dr. V. Petrow (British Drug Houses Ltd.). We also thank Mrs. J. Fair (Mill Hill) and Mr. W. McCorkindale (Glasgow) for microanalyses, Miss N. Caramando (Glasgow) for infrared spectra, and Mr. J. Grant (Mill Hill) for technical assistance.