

88. *A New Reaction of Hydrazones.*

By D. H. R. BARTON, R. E. O'BRIEN, and S. STERNHELL.

An improved preparation of hydrazones, with triethylamine as catalyst, has been developed. Oxidation of aldehyde or ketone hydrazones by iodine in neutral medium affords the corresponding azines. In a limited number of examples, oxidation with iodine in the presence of triethylamine proceeds differently and furnishes either (from aldehyde hydrazones) *gem*-di-iodides or (from ketone hydrazones) vinyl iodides. Iodo-analogues of testosterone and progesterone have been prepared by this procedure. Mechanistic considerations are presented.

DURING our recent work¹ on the constitutions of the citrus bitter principles we wished to inter-relate limonin (as I) with obacunone (as III) through iso-obacunoic acid (as II). This problem amounted, in essence, to the conversion of an angular aldehyde group into methyl. The conventional methods cannot be used for this purpose because of the multiplicity of sensitive groups in the molecule and we therefore sought a new, and milder, procedure. Although we have not, in fact, attained our initial objective, we did develop a method which has had some interesting ramifications. In the meantime the bitter principles limonin and obacunone have been correlated in an indirect, but elegant, manner by Kubota and his colleagues.²

We reasoned that an aldehyde hydrazone should be oxidisable to an unstable diazo-derivative which would react with iodine to give a *gem*-di-iodo-compound in the same way that diazomethane gives methylene di-iodide. Reduction with zinc dust would then complete the desired transformation. However, since hydrazones are normally formed

¹ Barton, Pradhan, Sternhell, and Templeton, *J.*, 1961, 255.

² Kubota, Matsuura, Tokoroyama, Kamikawa, and Matsumoto, *Tetrahedron Letters*, 1961, 325.

under rather vigorous conditions, we had first to find a general method for making these derivatives by a milder procedure. This was easily done by using triethylamine under reflux as the alkaline catalyst.

It seemed to us that iodine might serve, not only to react with the diazo-derivative, but also to oxidise the hydrazone itself. In the event, pivalaldehyde (IV; X = O) was converted into its hydrazone (IV; X = :N·NH₂) and oxidised with iodine in triethylamine-ether to the desired *gem*-di-iodo-derivative (V). The constitution of this compound was uniquely defined by its nuclear magnetic resonance spectrum as well as by reduction with zinc in acetic acid to neopentane. The di-iodide (V) is remarkably stable and does not deteriorate on storage.

In a similar experiment the benzyl ether of isovanillin (VI; X = O) was converted into its hydrazone (VI; X = :N·NH₂) and oxidised with iodine in tetrahydrofuran and triethylamine. Reduction of the product with zinc dust then gave 4-benzyloxy-3-methoxy-toluene. It was interesting that, if the triethylamine was omitted from the oxidation procedure, only the azine of the aldehyde (VI; X = O) was produced.³

Clearly this new procedure will serve to transform aldehydo- into methyl groups under mild conditions. We then sought to apply it to ketones. 3 β -Hydroxypregn-5-en-20-one (VII; X = O) was converted into its hydrazone (VII; X = :N·NH₂) and then oxidised with iodine in tetrahydrofuran-triethylamine. The main product was not the 20,20-di-iodide but the vinyl iodide (VIII; R = I), whose constitution was shown by its composition, infrared spectrum, and reduction with sodium and ethanol to the olefin (VIII; R = H) (characterised as acetate⁴). Oppenauer oxidation of the vinyl iodide (VIII; R = I) afforded the progesterone analogue (IX).

In similar experiments 3 β -hydroxy-5 α -pregnan-20-one (X; X = O), characterised as its oxime, was converted into the hydrazone (X = :N·NH₂) and this was oxidised with iodine in tetrahydrofuran. The sole product was the azine. In contrast, oxidation in triethylamine-tetrahydrofuran gave the vinyl iodide (XI), the constitution of which was shown by its infrared and nuclear magnetic resonance spectra. Systematic experiments (see p. 474) on the oxidation of the hydrazone (X; X = :N·NH₂) in benzene-triethylamine or tetrahydrofuran-triethylamine showed that yields of vinyl iodide (XI) of 60—70% could easily be attained with recovery of 10—20% of 3 β -hydroxy-5 α -pregnan-20-one (X; X = O). Dryness of solvents and exclusion of oxygen were preferable, but not mandatory.

We have also conducted some experiments in the testosterone series. 3 β -Acetoxy-androst-5-en-17-one (XII; R = Ac, X = O) and hydrazine-triethylamine gave, with concomitant hydrolysis of the ester group, the hydrazone (XII; R = H, X = :N·NH₂). Oxidation with iodine in triethylamine-tetrahydrofuran then furnished the vinyl iodide (XIII; R = I), whose constitution was shown by its nuclear magnetic resonance spectrum and by reduction with sodium and ethanol to the known 3 β -hydroxyandrosta-5,16-diene (XIII; R = H).⁵ This method of preparation of steroidal Δ^{16} -olefins seems to have some merit of convenience and simplicity over those used hitherto. Oppenauer oxidation of the vinyl iodide (XIII; R = I) afforded the testosterone analogue (XIV).

The above reactions have several implications of mechanistic interest. The dichotomy of mechanism implied by the isolation of azines from neutral iodine oxidation and of *gem*-di-iodides or vinyl iodides from oxidation in the presence of triethylamine is maintained in the reactions of benzophenone hydrazone. Oxidation with iodine in ether affords only the azine. Oxidation with iodine in the presence of triethylamine gives diphenyldiazomethane (identified by its colour and by reaction with hydriodic acid to give bisdiphenylmethyl ether). Model experiments in which mercuric oxide was used for oxidation showed

³ Cf. Curtius *et al.*, *J. prakt. Chem.*, 1891, **44**, 161, 192, 535.

⁴ Julian, Meyer, and Printi, *J. Amer. Chem. Soc.*, 1948, **70**, 887; Barton, Holness, and Klyne, *J.*, 1949, 2456.

⁵ Sondheimer, Mancera, Urquiza, and Rosenkranz, *J. Amer. Chem. Soc.*, 1955, **77**, 4145.

that the results were significant. Stable diazo-compounds were not obtained in any other experiments but, of course, diphenyldiazomethane is exceptionally stabilised.

The results can be most simply explained in the following way. Oxidation of a hydrazone (XV) with neutral iodine solutions³ gives the radical (XVI), which by dimeris-

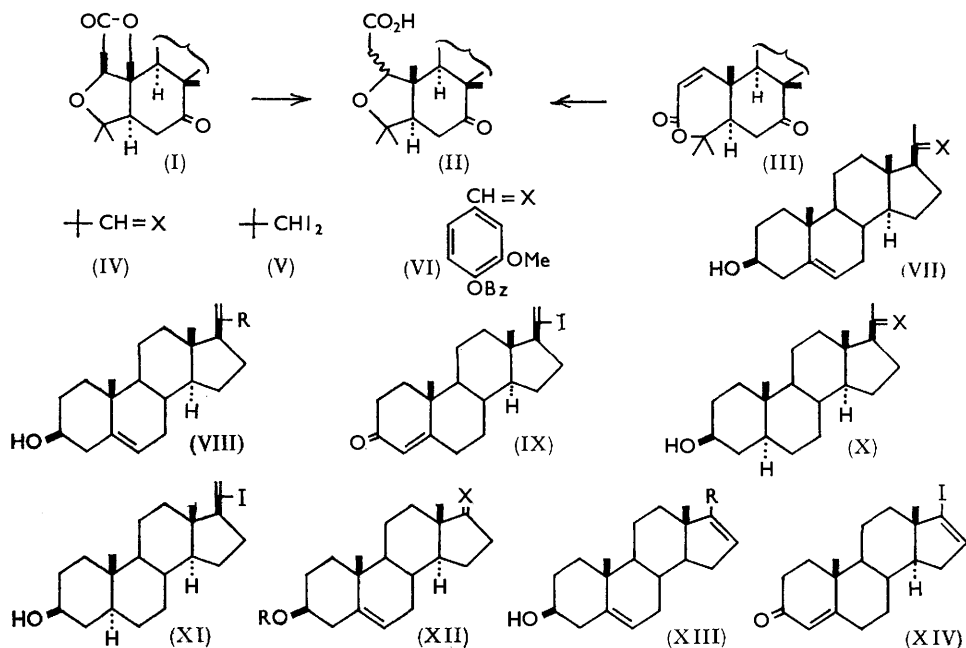

ation affords (XVII) (or equivalent structure). This is oxidisable further with loss of nitrogen to the azine (XVIII). In the presence of triethylamine, on the other hand, base-catalysed iodination furnishes the iodo-hydrazone (XIX) which loses hydrogen iodide through the action of triethylamine to give the diazo-hydrocarbon (XX). Attack upon the latter by I^- affords the intermediate (XXI) which is transformed by loss of nitrogen into (XXII). Uptake of I^- by the latter then gives the *gem*-di-iodide (XXIII). Loss of

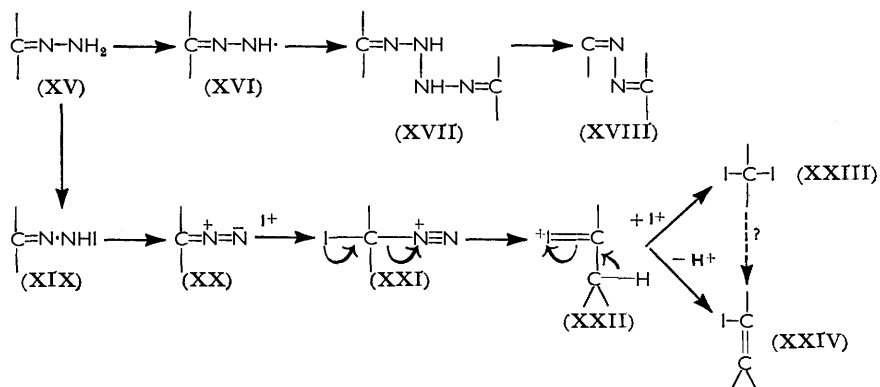

hydrogen iodide from the latter or, more probably, loss of a proton from (XXII) furnishes the vinyl iodide (XXIV).

The progesterone and testosterone analogues, (IX) and (XIV) respectively, were kindly examined by Glaxo Laboratories for androgenic, oestrogenic, and progestational activity. None was found.

During the present work, but independently of the conception thereof, the oxidation of several types of acid hydrazides by iodine-triethylamine was reported.⁶

EXPERIMENTAL

M. p.s were taken on the Kofler block. Unless specified to the contrary, $[\alpha]_D$ refer to CHCl_3 and ultraviolet absorption spectra to EtOH solutions, and infrared spectra to Nujol mulls. Light petroleum refers to the fraction of b. p. 40–60° unless specified to the contrary. The nuclear magnetic resonance spectra were kindly determined and interpreted by Drs. L. M. Jackman and J. W. Lown.

Benzophenone Hydrazone.—(a) Benzophenone (4.05 g.) in 64% hydrazine (3 ml.) and ethanol (30 ml.) containing potassium hydroxide (10 g.) was heated on the steam bath for 10 min. On cooling, benzophenone azine separated. Recrystallised from ethanol this formed needles (2.98 g.), m. p. 162–164°, λ_{max} 278 m μ (ϵ 19,000), ν_{max} 1600 (C=N) cm^{-1} .

(b) Benzophenone (6.0 g.) in 64% hydrazine (2.5 ml.) and ethanol (1.5 ml.) was heated in a sealed tube at 150° for 4 hr. Crystallisation of the product from aqueous ethanol afforded benzophenone hydrazone (5.77 g.), m. p. 97–98°, λ_{max} 276 m μ (ϵ 11,500) ν_{max} 3300 and 3150 (NH_2) and 1640 (C=N) cm^{-1} . In a second procedure benzophenone (3.53 g.) in 64% hydrazine (10 ml.) and 10% ethanolic potassium hydroxide (30 ml.) was heated on the steam bath for 2½ hr. Crystallisation from aqueous ethanol afforded the hydrazone (2.62 g.).^{3,7}

(c) Benzophenone hydrazone (836 mg.) and yellow mercuric oxide (1.4 g.) were shaken in light petroleum (20 ml.) for 8 hr. in the dark. The deep purple solution of diphenyldiazomethane was filtered and poured into ether and shaken with aqueous hydriodic acid (d 1.7; 3 ml.) for a few minutes at room temperature. Working up and crystallisation from ethanol gave bisdiphenylmethyl ether (535 mg.), m. p. 110° undepressed on admixture with an authentic specimen.⁸

(d) Benzophenone hydrazone (100 mg.) in ether (50 ml.) was treated with an excess of iodine in the same solvent at room temperature for 10 min. Crystallisation of the product from ethanol gave benzophenone azine (m. p., mixed m. p., and infrared spectrum).

(e) Benzophenone hydrazone (960 mg.) in dry ether (30 ml.) and triethylamine (1 ml.) was treated with an excess of iodine in dry ether. The iodine colour rapidly faded and was replaced by that of diphenyldiazomethane, triethylamine hydriodide being precipitated. The diphenyldiazomethane was characterised as under (c) above.

3 β -Hydroxy-5 α -pregnan-20-one Hydrazone.—(a) The ketone (1.09 g.) in 64% hydrazine (10 ml.) and 10% ethanolic potassium hydroxide (25 ml.) was refluxed for 1½ hr. Crystallisation of the product from methylene dichloride–light petroleum gave the *hydrazone* (860 mg.) as prisms, m. p. 190°, resolidified, remelted 237°, $[\alpha]_D +6^\circ$ (c 1.5 in tetrahydrofuran), ν_{max} 3450 and 3360 (NH_2) and 1638 (C=N) cm^{-1} (Found: C, 75.6; H, 10.85; N, 8.4. $\text{C}_{21}\text{H}_{36}\text{N}_2\text{O}$ requires C, 75.85; H, 10.9; N, 8.45%).

Alternatively the ketone (3.67 g.) in ethanol (35 ml.), triethylamine (8 ml.), and 64% hydrazine (16 ml.) was refluxed for 1½ hr. Crystallisation of the product from aqueous ethanol gave the hydrazone (3.57 g.) (m. p., mixed m. p., and infrared spectrum).

(b) The hydrazone (548 mg.) in tetrahydrofuran (25 ml.) was treated at room temperature with iodine (2.0 g.) in the same solvent (10 ml.) for 15 min. Crystallisation of the product from methylene dichloride–benzene–light petroleum gave *3 β -hydroxy-5 α -pregnan-20-one azine* (in essentially quantitative yield), m. p. 241–248°, $[\alpha]_D +108^\circ$ (c 1.50 in CHCl_3), ν_{max} 3230 (OH) and 1615 (C=N) cm^{-1} (Found: N, 4.5. $\text{C}_{42}\text{H}_{58}\text{N}_2\text{O}_2$ requires N, 4.45%).

(c) The hydrazone (520 mg.) in tetrahydrofuran (25 ml.) and triethylamine (2 ml.) was treated with iodine (2 g.) in the same solvent (10 ml.) at room temperature. Initially the iodine colour was discharged, triethylamine hydriodide being precipitated (m. p., mixed m. p., and infrared spectrum) and gas evolved. The reaction was immediate at room temperature. An excess of acetic acid was added and the mixture worked up in the usual way. Crystallisation from methanol gave *20-iodo-5 α -pregn-20-en-3 β -ol* (252 mg.), m. p. 148–149°, $[\alpha]_D -13^\circ$ (c 1.1

⁶ Brown and Hamer, *Proc.*, 1960, 212; cf. Wolman, Gallop, and Patchornik, *J. Amer. Chem. Soc.*, 1961, **83**, 1263.

⁷ Staudinger, Anthes, and Pfenninger, *Ber.*, 1916, **49**, 1928.

⁸ Ward, *J.*, 1924, **125**, 2285.

in CHCl_3 , λ_{max} . 208, 220 and 262 $\text{m}\mu$ (ϵ 6050, 6300, and 450, respectively), ν_{max} . 3180 (OH), 1599 (C=C), and 887 ($\text{C}=\text{CH}_2$) cm^{-1} , τ 4.05 and 3.90 (J 9 c.p.s.) ($\text{C}=\text{CH}_2$) (Found: C, 58.3; H, 7.6; I, 29.1. $\text{C}_{21}\text{H}_{33}\text{IO}$ requires C, 58.85; H, 7.75; I, 29.6%).

(d) 3 β -Hydroxy-5 α -pregnan-20-one (4.0 g.) in pyridine (40 ml.) containing hydroxylamine hydrochloride (11 g.) was heated in the steam bath for 35 min. Crystallisation from aqueous ethanol gave the *oxime* (3.48 g.), m. p. 231—232°, $[\alpha]_{\text{D}} + 30^\circ$ (*c* 2.3 in pyridine), ν_{max} . 3320, 3220 (OH) and 1650 ($\text{C}=\text{N}$) cm^{-1} (Found: C, 75.95; H, 10.6; N, 4.0. $\text{C}_{21}\text{H}_{35}\text{NO}_2$ requires C, 75.65; H, 10.6; N, 4.2%).

Systematic Experiments on the Oxidation of 3 β -Hydroxy-5 α -pregnan-20-one Hydrazone.—The experimental procedure was as follows. The hydrazone (400 mg.) in dry (alumina; grade I) triethylamine and dry (sodium) benzene was treated with iodine (2.0 g.) in dry benzene (20 ml.) at room temperature under dry oxygen-free nitrogen. After nitrogen evolution had ceased the mixture was extracted successively with 2N-hydrochloric acid, water, aqueous sodium sulphite, water, and saturated sodium hydrogen carbonate solution. The benzene solution was dried (MgSO_4) and taken to dryness *in vacuo* to give a semi-solid (563 mg.). The latter, in benzene (50 ml.) was chromatographed over alumina (50 g.; grade III). Elution with benzene (700 ml.) and with 1 : 19 chloroform–benzene (300 ml.) gave only traces of material. Elution with 7 : 93 chloroform–benzene afforded the expected vinyl iodide (343 mg.). Further elution with the same solvent furnished 3 β -hydroxy-5 α -pregnan-20-one (39 mg.), identified by m. p., mixed m. p., and infrared spectrum and by conversion into its acetate (m. p., mixed m. p., and infrared spectrum). The Table shows some variations upon these conditions.

Solvent	Conditions, as varied	Vinyl iodide (%)	3 β -Hydroxy-5 α -pregnan-20-one (%)
Benzene	As above	66	10
Benzene	Air instead of nitrogen, solvents not dried	59	16
Benzene	Under reflux	68	11
Tetrahydrofuran	As above	65	11
Tetrahydrofuran	Air instead of nitrogen	56	19
Tetrahydrofuran	Air instead of nitrogen, solvents not dried	45	24

3 β -Hydroxypregn-5-en-20-one Hydrazone.—(a) 3 β -Hydroxypregn-5-en-20-one (4.02 g.) in ethanol (40 ml.) and triethylamine (15 ml.) was refluxed with 64% hydrazine (2.5 ml.) for 2 hr. Pouring into water gave the crystalline *hydrazone* (3.51 g.). Recrystallised from aqueous ethanol this had m. p. 205—215°, followed by decomp. at 265°, $[\alpha]_{\text{D}} + 25^\circ$ (*c* 1.80), ν_{max} . 3400 (OH and NH) and 1630 ($\text{C}=\text{N}$) cm^{-1} (Found: C, 76.15; H, 10.4; N, 8.65. $\text{C}_{21}\text{H}_{34}\text{N}_2\text{O}$ requires C, 76.3; H, 10.35; N, 8.5%).

(b) The hydrazone (1.95 g.) in tetrahydrofuran (100 ml.) and triethylamine (50 ml.) was treated with iodine (8 g.) in tetrahydrofuran (25 ml.) with cooling (tap water). Working up as usual and crystallisation from aqueous ethanol afforded 20-iodopregna-5,20-dien-3 β -ol (2.03 g.), m. p. 142—144°, $[\alpha]_{\text{D}} - 67^\circ$ (*c* 1.20), ν_{max} . 3350 (OH), 1610 and 1601 (C=C), and 890 ($\text{C}=\text{CH}_2$) cm^{-1} (Found: C, 59.55; H, 7.4; I, 28.55. $\text{C}_{21}\text{H}_{31}\text{IO}$ requires C, 59.1; H, 7.3; I, 29.8%). Treatment of this diene (810 mg.) with pyridine (8 ml.) and acetic anhydride (8 ml.) overnight at room temperature gave the *acetate*. Recrystallised from methylene dichloride–ethanol this (800 mg.) had m. p. 151—153°, $[\alpha]_{\text{D}} - 69^\circ$ (*c* 2.20), ν_{max} . 1730 and 1235 (OAc) and 1608 (C=C) cm^{-1} (Found: C, 58.9; H, 7.1; I, 27.35. $\text{C}_{23}\text{H}_{33}\text{IO}_2$ requires C, 58.9; H, 7.05; I, 27.1%).

(c) 20-Iodopregna-5,20-dien-3 β -ol (680 mg.) in ethanol (20 ml.) was refluxed with sodium (5 g.) until dissolved. Treatment of the product with pyridine–acetic anhydride overnight at room temperature gave, after filtration in benzene–light petroleum through alumina (grade III) and crystallisation from methanol, 3 β -acetoxyregna-5,20-diene, identified by comparison (m. p., mixed m. p., and infrared spectrum) with authentic material.⁴

20-Iodopregna-4,20-dien-3-one.—Aluminium isopropoxide (10.01 g.), 20-iodopregna-5,20-dien-3 β -ol (2.93 g.), cyclohexanone (9.18 g.), and freshly distilled toluene (300 ml.) were heated under reflux for 4 hr. After working up in the usual way, the excess of cyclohexanone being removed by steam distillation, the oily product in light petroleum (b. p. 60—80°) was chromatographed over alumina (grade III). Elution with chloroform gave 20-iodopregna-4,20-dien-3-one (1.79 g.), m. p. 125—126° (from light petroleum), $[\alpha]_{\text{D}} + 68^\circ$ (*c* 1.10), λ_{max} . 244 $\text{m}\mu$ (ϵ 17,900) (Found: C, 59.15; H, 6.85; I, 29.95. $\text{C}_{21}\text{H}_{29}\text{IO}$ requires C, 59.45; H, 6.85; I, 29.95%).

O-Benzylisovanillin Hydrzone.—(a) The aldehyde⁹ (4.64 g.) in ethanol (40 ml.) and triethylamine (15 ml.) was refluxed with 64% hydrazine (20 ml.) for 30 min. The mixture was poured into water and the crystalline *O-benzylisovanillin hydrazone* collected (4.20 g.); it had m. p. 105° and resolidified, then remelted at 195° (azine) (Found: C, 69.8; H, 6.25; N, 11.0. C₁₅H₁₆N₂O₂ requires C, 70.3; H, 6.3; N, 10.95%). During several crystallisations from aqueous ethanol this compound changed into the azine (see below).

(b) The hydrazone (960 mg.) in tetrahydrofuran (25 ml.) and ether (20 ml.) was treated with an excess of iodine in ether at room temperature. The solution was poured into aqueous sodium sulphite, and the yellow crystals formed at the interface were collected (690 mg.). Crystallisation from methylene dichloride-ethanol furnished *O-benzylisovanillin azine*, m. p. 197—198° (Found: C, 74.7; H, 6.0; N, 5.85. C₃₀H₂₈N₂O₄ requires C, 75.0; H, 5.85; N, 5.85%).

(c) The hydrazone (2.16 g.) in tetrahydrofuran (30 ml.) and triethylamine (10 ml.) was treated with an excess of iodine in tetrahydrofuran with cooling to 20°. After nitrogen evolution had ceased, the solution was poured on to a suspension of zinc dust (50 g.) in acetic acid (50 ml.) and heated on the steam bath for 15 min., low-boiling solvent being allowed to evaporate. Working up in the usual way gave an oil (1.03 g.). This was chromatographed over alumina (grade III; 8 g.), elution with benzene-light petroleum furnishing crystalline *3-benzoyloxy-4-methoxytoluene* (470 mg.). Recrystallised from light petroleum, this had m. p. 51—54° (Found: C, 79.0; H, 6.95. C₁₅H₁₆O₂ requires C, 78.9; H, 7.05%).

3β-Hydroxyandrosta-5-en-17-one Hydrazone.—(a) The ketone acetate (4.16 g.) in ethanol (25 ml.), triethylamine (6 ml.), and 64% hydrazine (18 ml.) was refluxed for 1½ hr. Working up as usual and crystallisation from aqueous ethanol afforded *3β-hydroxyandrosta-5-en-17-one hydrazone* (2.33 g.) as needles, m. p. 287° after sintering at 210°, [α]_D -35° (c 1.2 in tetrahydrofuran), ν_{max.} 3360 and 3260 (NH₂), and 1662 (C=N) cm.⁻¹ (Found: C, 75.2; H, 9.8; N, 9.35. C₁₉H₃₀N₂O requires C, 75.45; H, 10.0; N, 9.25%).

(b) The hydrazone (464 mg.) in tetrahydrofuran (10 ml.) and triethylamine (2 ml.) was treated with iodine in the same solvent as in the preceding example. Crystallisation of the product from aqueous ethanol gave *17-iodoandrosta-5,16-dien-3β-ol* (290 mg.), m. p. 172—174°, [α]_D -53° (c 1.05 in EtOH), λ_{max.} 208, 213, 218, and 250 mμ (ε 8000, 7400, 7350, and 400 respectively), ν_{max.} 3240 (OH) and 1645 (C=C) cm.⁻¹, τ 4.66 and 3.89 (vinyl-H) (Found: C, 56.9; H, 7.05; I, 31.35. C₁₉H₂₇IO requires C, 57.3; H, 6.9; I, 31.85%).

Androsta-5,16-dien-3β-ol.—*17-Iodoandrosta-5,16-dien-3β-ol* (300 mg.) in ethanol (20 ml.) was treated under reflux with sodium (3 g.) for 1 hr. (all the sodium dissolved). Most of the solvent was removed *in vacuo*, to give crystalline *androsta-5,16-dien-3β-ol* (220 mg.). Recrystallised from aqueous methanol this had m. p. 140—141°, [α]_D -53° (c 1.30 in MeOH), λ_{max.} 204 mμ (ε 4600), ν_{max.} 3300 (OH) and 1666 and 1645 (C=C) cm.⁻¹, three vinyl-hydrogens in the nuclear magnetic resonance spectrum (Found: C, 83.75; H, 10.45. Calc. for C₁₉H₂₈O: C, 83.75; H, 10.35%).

17-Iodoandrosta-4,16-dien-3-one.—Aluminium isopropoxide (8.37 g.) in freshly distilled toluene (30 ml.) was heated under reflux with *17-iodoandrosta-5,16-dien-3β-ol* (1.89 g.) in cyclohexanone (8.5 g.) and toluene (100 ml.) for 2 hr. After working up in the usual way, the excess of cyclohexanone being removed in steam, a yellow solid (860 mg.) remained. Crystallisation from aqueous ethanol gave *17-iodoandrosta-4,16-dien-3-one* (435 mg.), m. p. 155—158°, [α]_D +118° (c 0.99), λ_{max.} 244 mμ (ε 16,500) (Found: C, 57.85; H, 6.65; I, 32.0. C₁₉H₂₅IO requires C, 57.6; H, 6.3; I, 32.05%).

Pivalaldehyde Hydrazone.—Pivalaldehyde (700 mg.) in ethanol (10 ml.), triethylamine (5 ml.), and 64% hydrazine (5 ml.) was refluxed for 30 min. The oily product (520 mg.) had an infrared spectrum showing NH₂ and C=N bands but no carbonyl band. This hydrazone (510 mg.) in ether (7 ml.) and triethylamine (2 ml.) was treated with an excess of iodine as in the preceding examples. The product was an oil (650 mg.) which, on distillation *in vacuo*, gave *1,1-di-iodoneopentane*, b. p. 100°/0.3 mm., n_D²⁰ 1.625, single peak on gas chromatography, no colour with aqueous potassium iodide, λ_{max.} 205 and 294 mμ (ε 1900 and 750, respectively), ν_{max.} (film) 2940—2820, 1475, 1460, 1382, 1365, 1265, 1225, 1185, 1085, 1020, 885, and 640 cm.⁻¹, τ 8.795 and 4.75 (9:1) (Found: C, 19.25; H, 3.15; I, 78.55. C₅H₁₀I₂ requires C, 18.55; H, 3.1; I, 78.35%).

1,1-Di-iodoneopentane (200 mg.) was suspended in glacial acetic acid (5 ml.) with addition of zinc dust (1.0 g.) and warmed on the steam bath whilst nitrogen was passed through the

⁹ Späth, Orechhoff, and Kuffner, *Ber.*, 1934, **67**, 1214.

mixture. The neopentane evolved was condensed in an acetone–solid carbon dioxide trap and identified by its nuclear magnetic resonance spectrum (τ 9.02, only band).

We thank the Government Grants Committee of the Royal Society, the Department of Scientific and Industrial Research, and Imperial Chemical Industries Limited for financial assistance. One of us (R. E. O'B) acknowledges the award of a Post-doctorate Fellowship from the U.S. Public Health Service, another (S. S.) a Studentship from the C.S.I.R.O. (Australia). We also thank the Research Institute for Medicine and Chemistry, Cambridge, Mass., for generous gifts of chemicals.

IMPERIAL COLLEGE OF SCIENCE AND TECHNOLOGY,
S. KENSINGTON, LONDON, S.W.7.

[Received, September 11th, 1961.]
