

**783. Chemistry of the Higher Fungi. Part XVI.<sup>1</sup> Polyacetylenic Metabolites from *Aleurodiscus roseus*.**

By R. C. CAMBIE, A. HIRSCHBERG, E. R. H. JONES, and G. LOWE.

The isolation and characterisation of eleven polyacetylenes, including six new compounds, from the culture medium of *Aleurodiscus roseus* are described. The new compounds include the C<sub>9</sub> diyne-allene alcohol [(+)-marasin] (IV), which is enantiomeric with marasin from *Marasmius ramealis*, these two being the first pair of enantiomeric allenes from natural sources; others are the corresponding acid (V) and its methyl ester (VI), the C<sub>9</sub> enediyne alcohol (VII), and the C<sub>9</sub> triyne and enediyne triols (IX and X) whose stereochemistry has been elucidated. The C<sub>9</sub> triynetriol (IX) is a diastereoisomer of the C<sub>9</sub> triynetriol (XIV) from *Coprinus quadrifidus*. The C<sub>9</sub> enediynetriol (X) is also the diastereoisomer of the C<sub>9</sub> enediynetriol (XVI) from *C. quadrifidus*, which had not been characterised fully in the earlier study. The tentative hydroxy-aldehyde structure (XVII) of another *C. quadrifidus* metabolite has been confirmed.

DURING our systematic screening of fungi for polyacetylenes the Basidiomycete *Aleurodiscus roseus* (Per. ex Fr.) v. Höhn. et Litsch. was observed to produce compounds exhibiting triyne, enetriyne, and enediyne chromophores. A comprehensive investigation of the metabolites has led to the isolation of eleven polyacetylenes (I—XI), including six new compounds (IV, V, VI, VII, IX, and X) whose structures and stereochemistry are now described. The extraction and fractionation procedures are outlined in the Experimental section and summarised in the Table.

		mg./l. (approx.)
(I)	$\text{CH}_3\cdot\text{C}\equiv\text{C}\cdot\text{C}\equiv\text{C}\cdot\text{C}\equiv\text{C}\cdot\text{CH}=\text{CH}\cdot\text{CH}_2\cdot\text{OH}$	10.0
(II)	$\text{CH}_3\cdot\text{C}\equiv\text{C}\cdot\text{C}\equiv\text{C}\cdot\text{C}\equiv\text{C}\cdot\text{CH}=\text{CH}\cdot\text{CHO}$	0.4
(III)	$\text{CH}_3\cdot\text{C}\equiv\text{C}\cdot\text{C}\equiv\text{C}\cdot\text{C}\equiv\text{C}\cdot\text{CH}=\text{CH}\cdot\text{CO}_2\text{H}$	0.2
(IV)	$(+)\text{-HC}\equiv\text{C}\cdot\text{C}\equiv\text{C}\cdot\text{CH}=\text{C}=\text{CH}\cdot\text{CH}_2\cdot\text{CH}_2\cdot\text{OH}$	4.4
(V)	$\text{HC}\equiv\text{C}\cdot\text{C}\equiv\text{C}\cdot\text{CH}=\text{C}=\text{CH}\cdot\text{CH}_2\cdot\text{CO}_2\text{H}$	0.08
(VI)	$\text{HC}\equiv\text{C}\cdot\text{C}\equiv\text{C}\cdot\text{CH}=\text{C}=\text{CH}\cdot\text{CH}_2\cdot\text{CO}_2\text{Me}$	0.02
(VII)	$\text{HC}\equiv\text{C}\cdot\text{C}\equiv\text{C}\cdot\text{CH}=\text{CH}\cdot\text{CH}_2\cdot\text{CH}_2\cdot\text{CH}_2\cdot\text{OH}$	0.06
(VIII)	$\text{HO}\cdot\text{CH}_2\cdot\text{CH}_2\cdot\text{C}\equiv\text{C}\cdot\text{C}\equiv\text{C}\cdot\text{CH}=\text{CH}\cdot\text{CH}_2\cdot\text{OH}$	0.8
(IX)	$\begin{array}{c} \text{HO} \quad \text{H} \\   \quad   \\ \text{HC}\equiv\text{C}\cdot\text{C}\equiv\text{C}\cdot\text{C}\equiv\text{C}\cdot\text{C}-\text{C}-\text{C}\cdot\text{CH}_2\cdot\text{OH} \\   \quad   \\ \text{H} \quad \text{OH} \end{array}$	2.2
(X)	$\begin{array}{c} \text{HO} \quad \text{H} \\   \quad   \\ \text{HC}\equiv\text{C}\cdot\text{C}\equiv\text{C}\cdot\text{CH}=\text{CH}\cdot\text{C}-\text{C}\cdot\text{CH}_2\cdot\text{OH} \\   \quad   \\ \text{H} \quad \text{OH} \end{array}$	1.4
(XI)	$\text{HC}\equiv\text{C}\cdot\text{C}\equiv\text{C}\cdot\text{CH}=\text{C}=\text{CH}\cdot\text{CH}(\text{OH})\cdot\text{CH}_2\cdot\text{CH}_2\cdot\text{CO}_2\text{H}$	0.3

A neutral non-polar fraction contained the bulk of the polyacetylenes and consisted mainly of the known C<sub>10</sub> triyne-ene alcohol, dehydromatricarianol<sup>2</sup> (I), and a diyne-allene alcohol (IV) separated by countercurrent distribution. The latter had a free ethynyl group, gave nonanol on hydrogenation, and was converted into a diyne-enol ether with alkali. These properties were consistent with its being the antibiotic marasin obtained by

<sup>1</sup> Part XV, Cambie, Jones, and Lowe, *J.*, 1963, 3466.

<sup>2</sup> Gardner, Jones, Leeming, and Stephenson, *J.*, 1960, 691.

Benz from *Marasmius ramealis*.<sup>3</sup> The identification was confirmed when countercurrent distribution with a sample from the latter source gave a smooth curve characteristic of a single compound. However, the material from *A. roseus* has optical rotation of equal and opposite sign to that of (-)-marasin from *M. ramealis* and is therefore the enantiomer (IV). This constitutes the first example of a natural allene occurring in enantiomeric forms. When tested against *Staphylococcus aureus* for antibiotic properties, (+)-marasin was comparable in activity with its enantiomer.

Present in leading tubes during countercurrent distribution, or in initial fractions from chromatography, of the neutral non-polar fraction were a triyne-ene aldehyde and a diyne-allene ester which were separated with difficulty by repeated chromatography on alumina. Once pure, the aldehyde was readily identified as the known *trans*-dec-2-ene-4,6,8-triyn-1-al (II).<sup>2</sup>

Fractionation of *Aleurodiscus roseus* extracts.

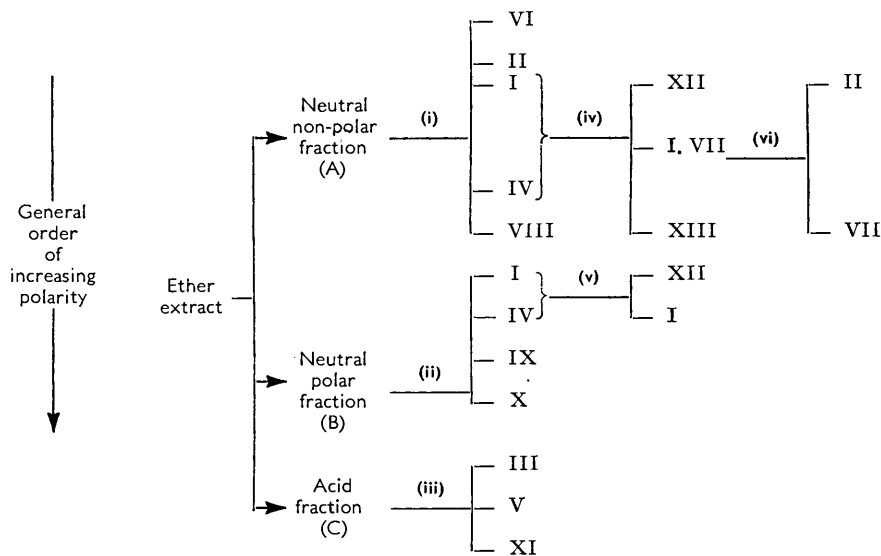

(i) Countercurrent distribution (a) and chromatography (a). (ii) Countercurrent distribution (b). (iii) Esterification and chromatography (b). (iv) Isomerisation and countercurrent distribution (c). (v) Isomerisation and chromatography (c). (vi) Manganese dioxide oxidation and chromatography (d).

The ester possessed an enediynes chromophore while its infrared spectrum showed that free ethynyl and allene groupings were present, that the ester was non-conjugated, and that no hydroxyl group was present. Hydrogenation gave methyl nonanoate. From these results the ester could be formulated as methyl nona-3,4-diene-6,8-diyneate (VI); a sample prepared by chromic acid oxidation of (+)-marasin, followed by methylation, possessed identical properties.

A more polar enediynes was contained in initial tubes of the above countercurrent distribution and was also isolated by chromatography of the neutral non-polar fraction on alumina. From its polarity it was considered to be a diol and was identified as the known *trans*-non-2-ene-4,6-diyne-1,9-diol (VIII) from its spectroscopic and chemical properties and by direct comparison with a synthetic sample.<sup>4</sup>

A mixture of (+)-marasin and dehydromatricarianol was present in tubes between those containing the bulk of these constituents. In order to effect complete separation of this mixture the marasin was isomerised by base to the non-hydroxylic isomarin (XII),<sup>3</sup> and the mixture redistributed between light petroleum and water. In addition to

<sup>3</sup> Bendz, *Arkiv Kemi*, 1959, **14**, 305, 475.

<sup>4</sup> Cambie, Gardner, Jones, Lowe, and Read, *J.*, 1963, 2056.

the expected products, dehydrömatricarianol and isomarasin, which were thus cleanly separated, this distribution revealed the presence of a triyne and of a minor enediyne differing from marasin.

The triyne alcohol possessed infrared bands characteristic of free ethynyl and primary hydroxyl groups and was identified as nona-4,6,8-triyn-1-ol (XIII) when hydrogenation and gas-liquid chromatography showed that its perhydro-derivative was nonanol. Contrary to the findings of Bendz,<sup>3</sup> we obtained about 25% of the triyne alcohol (XIII) by alkali-isomerisation of marasin; conversion of the triyne (XIII) into isomarasin (XII) requires more vigorous conditions than for marasin itself.<sup>5</sup> For this reason and because of the small amount obtained during the present work, coupled with the failure to detect it during initial countercurrent distribution before isomerisation, it is considered that compound (XIII) is not a metabolite of *A. roseus* but merely a by-product of the working-up procedure.



The minor enediyne material was not cleanly separated from dehydrömatricarianol during the above distributions but could be separated, by this method or by chromatography on alumina, after the dehydrömatricarianol had been oxidised to its corresponding aldehyde (II) with manganese dioxide. Even so it was never obtained in a pure state in spite of repetition of the purification steps involving base isomerisation and further chromatography. The infrared spectrum of the purest fraction indicated the presence of a hydroxyl group, a terminal acetylenic hydrogen, and a *trans*-double bond. A very weak band at 1957 cm.<sup>-1</sup> showed the presence of a persistent trace of an allene. Hydrogenation gave only nonanol. From this evidence and the stability to oxidation by manganese dioxide it seems that this metabolite must be the new *trans*-non-4-ene-6,8-diyn-1-ol (VII), but the low yield and its instability precluded further investigation.

A neutral polar fraction from the culture fluid contained triyne and enediyne components, separated by countercurrent distribution. From leading tubes more of the alcohols (I) and (IV) were isolated and identified as before. The triyne material possessed a symmetrical distribution curve, homogeneity was ensured by redistribution, and it was obtained crystalline at low temperature but was extremely unstable, decomposing rapidly at 20° and explosively at higher temperatures. Its ultraviolet spectrum was identical with that of the (2*D* : 3*D*)-triol (XIV) from *Coprinus quadrididus*,<sup>7</sup> and the structural investigation was pursued along similar lines to those used before.<sup>7</sup> This triynetriol was insoluble in solvents suitable for infrared measurements, but the presence of an ethynyl group was indicated by its extreme instability and the formation of a silver derivative. The product of periodic acid oxidation showed the chromophore of a triyne aldehyde while its infrared spectrum confirmed the presence of free ethynyl and aldehyde groups.

Hydrogenation gave a crystalline nonane-1,2,3-triol, C<sub>9</sub>H<sub>20</sub>O<sub>3</sub>, whose melting point and optical rotation differed from those of (2*D* : 3*D*)-nonane-1,2,3-triol,<sup>7</sup> but whose structure was confirmed by periodate oxidation to heptaldehyde. The perhydro-triol formed a tribenzoate which, unlike that from (2*D* : 3*D*)-nonane-1,2,3-triol, was only obtained as a high-boiling liquid and its small amount precluded rigorous purification. The triynetriol thus possessed the same gross structure as (XIV) but its optical rotation and those of its derivatives indicate that it must be either the (2*D* : 3*L*)- or (2*L* : 3*D*)-diastereoisomer.

The triynetriol was readily isomerised with base to a diyne-enol ether (XV) with spectral data identical with those of the corresponding derivative from the (2*D* : 3*D*)-triol, but with a quite different optical rotation. Ozonolysis of this compound gave a lactone identical with (+)-threonolactone prepared from (+)-ascorbic acid.<sup>8</sup> The (+)-threonic

<sup>5</sup> Bew, Jones, and Lowe, unpublished work.

<sup>6</sup> Jones and Leeming, unpublished work.

<sup>7</sup> Jones and Stephenson, *J.*, 1959, 2197.

<sup>8</sup> Gatzl and Reichstein, *Helv. Chem. Acta*, 1937, 20, 1298.

acid phenylhydrazides from each source were also identical. Since the initial configurations of the two secondary hydroxyl groups of the triynetriol are retained in its isomer (XV) the full structure of the triynetriol is given by the projection (IX), called (2*D* : 3*L*)-nona-4,6,8-triyn-1,2,3-triol on Linstead's convention.<sup>9</sup>

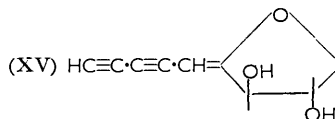
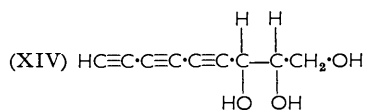

The enediyne component was purified further by countercurrent distribution and by chromatography of its isopropylidene derivative on alumina. Regeneration with hydrochloric acid gave pure enediyne material as an optically active oil which was again insoluble in solvents suitable for infrared measurements. The presence of an ethynyl group was indicated by its instability and the formation of a silver derivative and was confirmed from the infrared spectrum of its isopropylidene derivative.

Periodic acid oxidation gave hept-2-ene-4,6-diyenal, with a typical diyne-ene-aldehyde chromophore; the infrared spectrum showed bands of an  $\alpha\beta$ -unsaturated aldehyde and a *trans*-double bond in addition to that of a free ethynyl grouping.

Hydrogenation of the parent gave a crystalline triol, identical in all respects with the (2*D* : 3*L*)-nonane-1,2,3-triol from (IX). It follows therefore that the enediyne component is (2*D* : 3*L*)-*trans*-non-4-ene-6,8-diyne-1,2,3-triol (X).

Also obtained from ether extracts of the culture fluid of *A. roseus* was a small acidic fraction exhibiting triyne-ene-carbonyl and enediyne chromophores; this was esterified and chromatographed on alumina. Initial fractions yielded the methyl ester of *trans*-dec-2-ene-4,6,8-triynoic acid (III),<sup>2</sup> while later fractions contained the methyl ester of nemotinic acid (XI),<sup>10</sup> each identified by previously described methods<sup>2,10</sup> and in the case of the ester of (III) by comparison with an authentic sample. The presence of a C<sub>11</sub> constituent, nemotinic acid, among the metabolites of *A. roseus* was unexpected. However, no attempt was made in the present work to differentiate between compounds produced in initial and reflow cultures, and the production of nemotinic acid by the fungus may parallel the behaviour of *Drosophila subatrata* which, although normally producing C<sub>11</sub> compounds,<sup>11</sup> also elaborates the C<sub>13</sub> compound, mycomycin,<sup>12</sup> in reflow cultures.<sup>6</sup> A similar production of mycomycin is shown in reflow cultures of *Odontia bicolor* which normally produces C<sub>10</sub> and C<sub>11</sub> metabolites.<sup>13</sup>

During the investigation of methyl nemotinate a fraction from chromatography immediately preceding the bulk of the compound and possessing an identical ultraviolet spectrum was examined. The fraction was of stability comparable with that of methyl nemotinate and possessed a similar infrared spectrum. Significantly, however, the spectrum showed only a very weak hydroxyl band, such as might be expected for a non-hydroxylic allene-diyne ester containing methyl nemotinate as impurity. Moreover, hydrogenation followed by gas-liquid chromatographic examination showed that methyl nonanoate was the major product. Insufficient material was available for complete purification but in view of the isolation of methyl nona-3,4-diene-6,8-diyneate (VI) from the neutral portion it seemed likely that the present ester was also that of nona-3,4-diene-6,8-diyneic acid (V). This was confirmed by comparison of the infrared spectrum with that of the authentic ester prepared from (+)-marasin and by countercurrent distribution, a smooth symmetrical distribution curve being obtained.

In addition to the metabolites of static cultures those of shake cultures of *A. roseus* were also examined. This resulted in the isolation of further (+)-marasin (IV) and

<sup>9</sup> Linstead, Lunt, and Weedon, *J.*, 1950, 3333.

<sup>10</sup> Bu'Lock, Jones, and Leeming, *J.*, 1955, 4270.

<sup>11</sup> Jones, Leeming, and Remers, *J.*, 1960, 2257.

<sup>12</sup> Celmer and Solomons, *J. Amer. Chem. Soc.*, 1952, **74**, 1870, and subsequent papers.

<sup>13</sup> Bew, Jones, Lowe, and Lowe, *J.*, 1963, 2048.

dehydromatricarianol (I) as the major constituents. An acidic fraction was also obtained which appeared to contain compounds different from those in the static cultures, but very low yields precluded comprehensive examination.

*Aleurodiscus roseus* thus produces almost exclusively C<sub>9</sub> and C<sub>10</sub> metabolites which form the bulk of all fungal polyacetylenes. Of particular interest is the isolation of (+)-marasin (IV), the enantiomer of the major polyacetylenic metabolite of *Marasmius ramealis*.<sup>3</sup> The triynetriol (XI) is the diastereoisomer of the major polyacetylenic metabolite of *Coprinus quadrifidus*.<sup>7</sup> The biogenetic sequence leading to the triol (XI), however, is not so clearly indicated as in *C. quadrifidus*<sup>7</sup> where the C<sub>9</sub> triyne-ene alcohol and the C<sub>9</sub> triyne-epoxy alcohol<sup>14</sup> of the appropriate stereochemistry were isolated together with the (2*D*:3*D*)-triynetriol (XIV). In spite of a careful search, no trace of an epoxy-alcohol related to the triol (XI) could be detected amongst the metabolites of *A. roseus*.

The racemate of marasin has recently been synthesised by Bohlmann and his co-workers<sup>15</sup> and thus its conversion into the corresponding acid and its ester (VI) in the present work constitutes a partial synthesis of these two metabolites. Projected syntheses of the alcohols (VII), (IX), and (X) are in progress.

In Part IX<sup>7</sup> the isolation of a neutral polar enediyne from *Coprinus quadrifidus* was briefly reported. With the material which was then available it proved impossible to be certain of its structure, although the evidence indicated that it might possibly be (2*D*:3*D*)-*trans*-non-4-ene-6,8-diyne-1,2,3-triol (XVI). In view of the isolation of the diastereoisomeric triol (X) from *A. roseus* the polar enediyne from *C. quadrifidus* was re-investigated. The compound was isolated as before<sup>7</sup> and separated from all traces of (2*D*:3*D*)-nona-4,6,8-triyne-1,2,3-triol (XIV) by countercurrent distribution. The compound was extremely unstable and insoluble in solvents suitable for determination of infrared spectra. The infrared spectrum of the isopropylidene derivative indicated the presence of an ethynyl group (3300 cm.<sup>-1</sup>) and a *trans* double bond (958 cm.<sup>-1</sup>). Periodic acid oxidation of the parent gave a solution with an ultraviolet absorption spectrum characteristic of a diynene-aldehyde. The structure was unequivocally established when catalytic hydrogenation (uptake of 5 mol.) gave (2*D*:3*D*)-nonane-1,2,3-triol, identical in all respects with that prepared from the triynetriol (XIV).

The further growth of *C. quadrifidus* made it possible to re-investigate the metabolite which exhibited its longest-wavelength maximum at 3510 Å. The tentative structure (XVIII) previously assigned<sup>7</sup> to this metabolite has now been confirmed although it has not been possible to obtain quantitative spectroscopic data because of the small amount of material available (*ca.* 2-5 mg.). Brief treatment with lithium aluminium hydride led to a product with a typical enediynene absorption spectrum which was probably *trans,trans*-deca-2,8-diene-4,6-diyne-1,10-diol formed by further reduction of the intermediate *trans*-dec-2-ene-4,6,8-triyne-1,10-diol. Hydrogenation of the product gave a crystalline perhydro-compound whose melting point was undepressed by decane-1,10-diol and whose identity was confirmed by comparative gas-liquid chromatography of its dimethyl ether with an authentic sample.

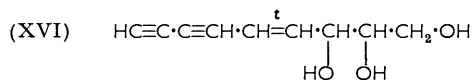

#### EXPERIMENTAL

For general experimental methods and conditions of culture growth see Part X<sup>2</sup> and earlier parts of this series. Ultraviolet spectra were measured for EtOH solutions on a Cary double-beam recording spectrophotometer. Infrared spectra, unless otherwise stated, were recorded

<sup>14</sup> Jones, Stephenson, Turner, and Whiting, *J.*, 1963, 2048.

<sup>15</sup> Bohlmann, Herbst, and Gleinig, *Chem. Ber.*, 1961, **94**, 948.

for CS<sub>2</sub> solutions on a Perkin-Elmer 21 instrument, and m. p.s (corrected) were determined on a Kofler block. Alumina refers to P. Spence grade "H" material deactivated with 5% of 10% acetic acid. Unless otherwise stated, light petroleum refers to the fraction with b. p. 60–80°. Gas-chromatographic conditions for perhydro-derivatives were those described in Part XIV.<sup>4</sup> Optical rotations are for EtOH solutions.

*Isolation of Polyacetylenes.*—*Aleurodiscus roseus* (Per. ex Fr.) v. Höhn. et Litsch. [obtained from the Type Culture Collection, Baarn (Netherlands)] was grown (average of 20 days) on a 3% malt medium and reflooded up to 4 times with a 4% glucose medium (average of 18 days). Continuous ether-extracts of each batch (total vol. of culture fluid ca. 250 l.) were concentrated to smaller volume (1 l.) and extracted with saturated aqueous sodium hydrogen carbonate (5 × 250 c.c.) and again with water (250 c.c.). The remaining ether solution gave the neutral non-polar fraction (A). The combined aqueous extracts were back-extracted with ether (6 × 200 c.c.) to yield the neutral polar fraction (B). The aqueous extracts were then acidified and extracted with ether (6 × 200 c.c.) to give an acid fraction (C).

#### Neutral Non-polar fraction (A).

*Separation of Constituents.*—The neutral non-polar fraction containing enetriyne (ca. 2.7 g.) and enediyne (ca. 1.2 g.) components was partially separated by countercurrent distribution (120-tube apparatus) between light petroleum–benzene (10 : 1)–water for 120 transfers or by chromatography on alumina from light petroleum–benzene (4 : 1) solution. In a typical distribution (a), tubes 1–36 contained (VIII), tubes 61–104 contained (IV), tubes 105–108 contained (IV) and (I), and tubes 109–120 contained (I), (IV), and (II). In a typical chromatogram (chromatogram a), fractions 1–3 (200 c.c.) eluted with light petroleum–benzene (4 : 1) contained mainly (II) and (VI), fraction 4 eluted with light petroleum–benzene (2 : 1) contained (II) and traces of (I) and (IV), fractions 5–10 eluted with light petroleum–benzene (1 : 1 and later 1 : 2) contained (I) and (IV) in decreasing and increasing concentrations, respectively, fractions 11–13 eluted with benzene, contained mainly (IV), and fractions 15–20 eluted with ether contained (VIII).

Other compounds present were not discerned in the above separations owing to the masking effect of the strong enetriyne and enediyne chromophores of (I) and (IV), respectively. Because of the imperfect and arbitrary separations and the complexity of the spectra no reliable quantitative estimations during initial distributions or chromatography could be made. For further purification, where possible, each fraction from the above separations was rechromatographed on alumina or redistributed between the same solvents.

*trans-Dec-2-ene-4,6,8-triyn-1-ol (Dehydromatricarianol; I).*—Spectroscopic estimation indicated the presence of ca. 2.5 g. of dehydromatricarianol. Material obtained by rechromatography on alumina (benzene elution), crystallised from dichloromethane–hexane as needles, m. p. and mixed m. p. 128–129° (decomp.). Infrared and ultraviolet spectroscopic data were identical with those of an authentic sample. Hydrogenation gave decanol, identified by gas–liquid chromatography.

*(+)-Nona-3,4-diene-6,8-diyn-1-ol [(+)-Marasin; IV].*—Spectroscopic estimation indicated the presence of ca. 1.1 g. of (+)-marasin. The pure compound had  $[\alpha]_D^{25} + 360^\circ$  (c 1.6),  $\lambda_{\max}$ . 2780 ( $\epsilon$  11,000), 2620 ( $\epsilon$  13,000), 2480 ( $\epsilon$  9000), 2370 ( $\epsilon$  4500), 2240 (infl.,  $\epsilon$  2500), and 2080 Å ( $\epsilon$  45,000), and  $\nu_{\max}$ . 3570 (OH), 3280 (HC≡C), 1940 (CH=C=CH), 1040 (C–OH), and 852 cm.<sup>-1</sup> (CH=C=CH). Co-distribution for 50 transfers with a sample of (–)-marasin from *Marasmius ramealis* gave a smooth distribution curve characteristic of a single compound. Hydrogenation over 5% palladium–charcoal gave nonanol, identified by gas–liquid chromatography.

An ethereal solution of (+)-marasin (10 mg.) was treated with 0.1N-sodium hydroxide (5 c.c.), the ether evaporated, and the mixture kept at 20° for 2 hr. Acidification followed by ether-extraction (2 × 10 c.c.) gave isomarasin (ca. 8 mg.),  $\lambda_{\max}$ . 2950 ( $\epsilon$  11,000), 2795 ( $\epsilon$  15,000), 2660 ( $\epsilon$  11,000), 2230 ( $\epsilon$  20,500), and 2080 Å ( $\epsilon$  54,500),  $\nu_{\max}$ . 3310 (HC≡C), 1634, 1147, and 1040 cm.<sup>-1</sup> (C=C–O), very similar to the spectral data of isomarasin obtained by Bendz.<sup>3</sup>

*Conversion of (+)-Marasin into Methyl Nona-3,4-diene-6,8-dienoate.*—A cooled (0°) and stirred solution of (+)-marasin (200 mg.) in dry acetone (20 c.c.) was treated dropwise with 8N-chromic acid until a brown colour persisted. The mixture was kept at 0° for 10 min. and at 20° for 5 min. and then poured into water. The acidic product, nona-3,4-diene-6,8-dienoic acid (50 mg.), isolated by means of ether and sodium hydrogen carbonate extractions, had

$\lambda_{\max}$ . (in ether) (relative  $\epsilon$  in parentheses) 2780 (1.0), 2630 (1.08), 2490 (0.80), and 2370 Å (0.51), but because of its instability no attempt at isolation was made.

The total acid fraction was esterified with 5% sulphuric acid in methanol, and the neutral product was isolated in the usual manner. Chromatography on alumina gave (+)-*methyl nona-3,4-diene-6,8-diyanoate* (40 mg.) from fractions eluted with light petroleum. The ester formed needles (from light petroleum at  $-70^\circ$ ) which liquified below  $20^\circ$  and rapidly polymerised; they had  $[\alpha]_D^{22} + 285^\circ$  ( $c$  0.2),  $\lambda_{\max}$ . 2780 ( $\epsilon$  10,000), 2620 ( $\epsilon$  11,000), 2490 ( $\epsilon$  8000), 2370 ( $\epsilon$  5000), and 2080 Å ( $\epsilon$  11,000), and  $\nu_{\max}$ . 2300 (HC $\equiv$ C), 1953 (CH=C=CH), 1750 (non-conjugated ester C=O), and 850  $\text{cm}^{-1}$  (CH=C=CH).

*trans-Dec-2-ene-4,6,8-triyn-1-al* (II).—Fractions 1—4 (containing *ca.* 100 mg. of the aldehyde) from chromatogram (a) were rechromatographed from light petroleum on alumina. Initial fractions contained (VI) (see below). Later fractions, exhibiting a triynenal chromophore, were repeatedly rechromatographed, to yield *trans-dec-2-ene-4,6,8-triyn-1-al* which finally crystallised from hexane as pale yellow needles (10 mg.), m. p.  $108-109^\circ$  (decomp.), undepressed by a sample prepared by oxidation of (I) with activated manganese dioxide. Ultraviolet and infrared spectroscopic data were identical with those recorded <sup>2</sup> and of an authentic sample.

*Methyl Nona-3,4-diene-6,8-diyanoate* (VI).—Fraction 1 from the chromatographic separation of (II) above, was rechromatographed on alumina to yield methyl nona-3,4-diene-6,8-diyanoate (*ca.* 4 mg.), with infrared and ultraviolet spectra identical with those of a synthetic sample (see above).

Hydrogenation (10% palladium-charcoal) gave methyl nonanoate as the major product, identified by gas-liquid chromatography.

*trans-Non-2-ene-4,6-diyne-1,9-diol* (VIII).—Combined solutions from distribution (a) and chromatogram (a), containing the polar enediynes, were rechromatographed from benzene on alumina. Fractions eluted with benzene contained traces of (I) and (IV), each separated and identified in the usual manner. Fractions eluted with benzene-ether (1:1) and ether contained the ene-diyne which after further chromatography crystallised from dichloromethane-hexane to yield *trans-non-2-ene-4,6-diyne-1,9-diol* as plates (153 mg.), m. p. and mixed m. p.  $58-59^\circ$ . Infrared and ultraviolet spectroscopic data were identical with those recorded <sup>4</sup> and of a synthetic sample.

The diol (100 mg.) was hydrogenated over pre-reduced 10% palladium-charcoal (50 mg.) with an uptake of 5.2 moles/mole (77.6 c.c. at N.T.P.), and the product chromatographed on Woelm neutral alumina (grade IV, 50 g.). Fractions eluted with light petroleum (b. p.  $30-40^\circ$ )-ether (10:1) gave nonane-1,9-diol (64 mg.), plates (from hexane), m. p. and mixed m. p.  $44-45^\circ$  (Found: C, 67.9; H, 12.7. Calc. for  $\text{C}_9\text{H}_{20}\text{O}_2$ : C, 67.5; H, 12.6%). The infrared spectrum was identical with that of authentic material and different from those of octane-1,8-diol and decane-1,10-diol. Hydrogenolysis of the ene-diyndiol in 20% ethanolic hydrochloric acid solution over Adams catalyst for 4 hr. gave nonanol as the major product, which was identified by gas-liquid chromatography.

Oxidation with activated manganese dioxide gave *trans-9-hydroxynon-2-ene-4,6-diyenal*.<sup>4</sup>

*Isomerisation of Neutral Non-polar Residues*.—Bulked fractions containing (I) and (IV) from distribution (a) and chromatogram (a) after separation of as much pure material as possible were transferred to 0.1N-sodium hydroxide (30 c.c.) and kept at  $20^\circ$  for 2 days. Continuous ether-extraction (24 hr.) and concentration to smaller volume gave a solution which was distributed in a Craig-type apparatus (120 tubes) between water and light petroleum [distribution (c)]. After 120 transfers tubes 1—36 contained (XIII), tubes 56—80 contained a mixture of (VII) and (I), and tubes 81—120 contained (I) and (XII).

Solutions recovered from tubes 81—120, on working-up and chromatography, yielded 120 mg. of (I) and 10 mg. of (XII), each identified in the usual way.

*Nona-4,6,8-triyn-1-ol* (XIII).—Material recovered from tubes 1—32 [distribution (c)] contained *nona-4,6,8-triyn-1-ol* (*ca.* 15 mg.),  $\lambda_{\max}$ . 2080 Å ( $\epsilon$  100,000),  $\nu_{\max}$ . 3546 (OH), 3300 (HC $\equiv$ C), 2242 (C $\equiv$ C), 1282, and 1042  $\text{cm}^{-1}$  (CH<sub>2</sub>·OH). The compound was not obtained crystalline. The triyne (10 mg.) in methanol solution was hydrogenated (5% palladium-charcoal) to yield only nonanol, identified by gas-liquid chromatography.

*Manganese Dioxide Oxidation of Isomerised Neutral Non-polar Residues*.—The contents of tubes 56—80 [distribution (c)], exhibiting enediynes and enetriynes chromophores, were shaken in dichloromethane solution (20 c.c.) with activated manganese dioxide (1 g.) for 4 days at  $20^\circ$ .

The mixture was filtered and washed well with ether. Solvent was removed from the combined filtrate and washings, and the product chromatographed [chromatogram (d)] on alumina (100 g.) from light petroleum solution. Initial fractions (150 c.c. each) eluted with light petroleum gave dehydromatricarianol (II, 47 mg.), m. p. and mixed m. p. 108—109° (decomp.).

*trans-Non-4-ene-6,8-diyne-1-ol* (VII).—Fractions eluted [chromatogram (d)] with benzene-ether contained ene-diyne (ca. 15 mg.) and were rechromatographed on alumina. Fractions then eluted with benzene-ether (5 : 1) contained *trans-non-4-ene-6,8-diyne-1-ol* (ca. 5 mg.) which was not obtained crystalline and decomposed rapidly below 20°. The compound had  $\lambda_{\max}$  (in ether) (relative  $\epsilon$  in parentheses) 2810 ( $\epsilon$  1.0), 2650 ( $\epsilon$  1.28), 2510 (1.19), 2380 (1.08), and 2290 Å (0.82), and  $\nu_{\max}$  3676 (OH), 3311 (HC≡C), and 948  $\text{cm}^{-1}$  (*trans*-CH=CH). The spectrum also showed a weak band at 1957  $\text{cm}^{-1}$  indicative of the presence of a trace of allene as impurity.

The compound was unaffected by treatment with activated manganese dioxide or by treatment with 0.1N-sodium hydroxide at 20°. Hydrogenation (10% palladium-charcoal) gave nonanol, identified by gas-liquid chromatography.

#### Neutral Polar Fraction (B).

*Isolation of Constituents*.—The neutral polar fraction containing triyne (ca. 560 mg.) and enediyne (ca. 300 mg.) was distributed between ether and m/15-potassium dihydrogen phosphate for 110 transfers in a Craig-type countercurrent apparatus (110 tubes). In a typical distribution [distribution (b)] tubes 36—60 contained (X), tubes 61—85 contained (IX), tubes 86—91 contained (XV), tubes 96—105 contained (IV), and tubes 106—110 contained a mixture of (I) and (IV).

Dehydromatricarianol (15 mg.), m. p. and mixed m. p. 127—128° (decomp.) (correct spectroscopic data), was recovered from tubes 106—110. The mother-liquors from crystallisation and the contents of tubes 96—105 were combined and isomerised with base in the usual manner. Chromatography on alumina [chromatogram (c)] yielded isomarasin (25 mg.) in fractions eluted with light petroleum and light petroleum-benzene (10 : 1), while fractions eluted with benzene contained further dehydromatricarianol (3 mg.), each identified in the usual way.

(2D : 3L)-*Nona-4,6,8-triyne-1,2,3-triol* (IX).—The triyne from tubes 61—85 [distribution (b)] was redistributed between the same solvents to ensure homogeneity. Further purification from ether-hexane at -70° gave (2D : 3L)-*nona-4,6,8-triyne-1,2,3-triol* (400 mg.) as a microcrystalline powder which rapidly became oily and decomposed at 20°,  $[\alpha]_{\text{D}}^{23}$  -8° (c 0.6),  $\lambda_{\max}$  3050 ( $\epsilon$  80), 2840 ( $\epsilon$  250), 2670 ( $\epsilon$  280), 2530 ( $\epsilon$  200), and 2080 Å ( $\epsilon$  120,000).

*Hepta-2,4,6-triynal*.—A solution of the triol (IX) (20 mg.) in water (20 c.c.) and ethanol (2 c.c.) was shaken with an excess of periodic acid in the dark for 8 hr. The mixture was diluted with water and extracted with ether, to yield hepta-2,4,6-triynal,  $\lambda_{\max}$  (relative  $\epsilon$  in parentheses) 3290 (1.0), 3080 (1.54), 2900 (1.64), 2740 (1.72), 2610 (infl., 1.54), and 2250 Å (9.6),  $\nu_{\max}$  3300 (HC≡C), 2732 (aldehydic CH), and 1675  $\text{cm}^{-1}$  (C≡C-CH=O).

(2D : 3L)-*Nonane-1,2,3-triol*.—The triyne (IX) (200 mg.) in methanol (20 c.c.) was hydrogenated over pre-reduced 10% palladium-charcoal at 18°. The uptake of hydrogen was 179 c.c. at N.T.P. (5.8 moles/mole). Catalyst was removed and the residue, after evaporation of solvent, crystallised from ether to yield (2D : 3L)-*nonane-1,2,3-triol* (180 mg.) as plates, m. p. 94—96°,  $[\alpha]_{\text{D}}^{24}$  +9° (c 0.25) (Found: C, 61.6; H, 11.1.  $\text{C}_9\text{H}_{20}\text{O}_3$  requires C, 61.3; H, 11.4%),  $\nu_{\max}$  (in Nujol) 3236—3175 (broad, OH), 1347, 1307, 1068 (C-OH), and 720  $\text{cm}^{-1}$ .

Treatment of the perhydro-triol (50 mg.) with benzoyl chloride and pyridine for 2 hr. at 100° gave an oil which was chromatographed on alumina. Fractions eluted with light petroleum-ether (10 : 1), containing the *tribenzoate* (62 mg.), were further purified by microdistillation, giving material having b. p. 190—195°/0.6 mm.,  $[\alpha]_{\text{D}}^{18}$  -3° (c 1.5) (Found: C, 74.5; H, 6.2.  $\text{C}_{30}\text{H}_{32}\text{O}_6$  requires C, 73.8; H, 6.6%), and  $\nu_{\max}$  (liquid) 1715 (ester C=O), 1269, and 1107  $\text{cm}^{-1}$  (C-OBz), and absence of OH absorption.

*Periodate Oxidation of (2D : 3L)-Nonane-1,2,3-triol*.—A solution of the perhydro-triol (3.0 mg.) in 50% aqueous ethanol (2 c.c.) consumed 2.13 mol. of 0.112N-sodium periodate. The mixture, after oxidation of further triol (100 mg.) with an excess of sodium periodate for 3 hr. at 20°, was diluted with water and extracted with ether. Removal of solvent from the dried extracts gave heptaldehyde,  $\nu_{\max}$  (liquid) 2681 (aldehydic CH), 1724 (CH=O), 1471, 952, and 724  $\text{cm}^{-1}$ . The 2,4-dinitrophenylhydrazone, needles from aqueous ethanol, had m. p. and mixed m. p. 108—109° (identical infrared spectrum) (Found: C, 53.3; H, 6.2; N, 19.3. Calc. for  $\text{C}_{13}\text{H}_{18}\text{N}_4\text{O}_4$ : C, 53.05; H, 6.2; N, 19.0%).



(3*D* : 4*L*)-Tetrahydro-2-(penta-2,4-diynylidene)furan-3,4-diol (XV).—An ethereal solution of the triol (IX) (160 mg.) was treated with 0.1*N*-sodium hydroxide, the ether removed at 20 mm., and the mixture kept at 20° in the dark for 24 hr. The solution was continuously extracted with ether for 12 hr., to yield the *enol ether* (150 mg.) which was obtained as a solid from ether-hexane at -70° but decomposed rapidly at 20° and explosively at higher temperatures. It had  $[\alpha]_D^{24} -15^\circ \pm 1^\circ$  (*c* 0.4),  $\lambda_{\max}$ . 2940 ( $\epsilon$  14,000), 2790 ( $\epsilon$  17,500), 2660 (infl.,  $\epsilon$  12,500), and 2250 Å ( $\epsilon$  23,500), and  $\nu_{\max}$ . 3460 (OH), 3300 (HC≡C), 2221 (C≡C), 1647 (C=C-O), 1348, and 1116 cm.<sup>-1</sup>.

Tubes 86—91 from distribution (b) above contained *ca.* 18 mg. of the same compound, identified in the usual way. It apparently arose from ready isomerisation (cf. ref. 7) of (IX) during fractionation of the original extracts of the fungus with sodium hydrogen carbonate solution.

(+)-Threonolactone.—The *enol ether* (XV) (150 mg.) in methanol (3 c.c.) was treated with ozone at -70° until a permanent blue colour appeared. Trimethyl phosphite (0.6 c.c.) was added after removal of the excess of ozone in nitrogen, and the mixture was kept at 20° for 12 hr. Solvent was removed and the resulting syrup extracted with ethyl acetate and separated from polymeric impurities. The resulting clarified oil (120 mg.) was chromatographed on silica gel. Elution with ethyl acetate gave an oil which crystallised during 1 month. Trituration with methanol (2 drops) and recrystallisation from ethyl acetate gave (+)-threonolactone as needles (41 mg.), m. p. 64—67°,  $[\alpha]_D^{18} +30^\circ$  (*c* 0.6 in H<sub>2</sub>O),  $[\alpha]_D^{18} +45^\circ$  (*c* 0.5 in MeOH). The m. p. was undepressed by an authentic sample, m. p. 65—68°,  $[\alpha]_D^{18} +30^\circ$  (*c* 1.0 in H<sub>2</sub>O), prepared in 40% yield by alkaline permanganate oxidation of (+)-ascorbic acid<sup>8</sup> (50 g.), and the infrared spectra were identical,  $\nu_{\max}$ . (in Nujol) 3340 (broad, OH), 3226 (hydrogen-bonded OH), and 1740 cm.<sup>-1</sup> ( $\gamma$ -lactone, lowered by hydrogen bonding; cf. ref. 7).

Phenylhydrazide of (+)-Threonic Acid.—Crude threonolactone (50 mg., from the ozonolysis) was dissolved in ethanol, treated with phenylhydrazine (1 c.c.), and warmed on the water-bath. The phenylhydrazide crystallised from methanol as needles,  $[\alpha]_D^{21} +47^\circ$  (*c* 0.5 in MeOH), m. p. 158—160°, undepressed by an authentic sample, m. p. 160—161°,  $[\alpha]_D^{20} +49^\circ$  (*c* 0.9 in MeOH),  $[\alpha]_D^{20} +28^\circ$  (*c* 1.2 in H<sub>2</sub>O) (identical infrared spectrum).

(2*D* : 3*L*)-trans-Non-4-ene-6,8-diyne-1,2,3-triol (X).—The enediyne material from tubes 36—40 [distribution (b)] was heated under reflux in dry acetone (50 c.c.) with toluene-*p*-sulphonic acid (100 mg.) for 12 hr. An excess of sodium carbonate was added, the mixture kept at 20° for 1 hr., then filtered, and the solvent removed. The residue was extracted with light petroleum-ether (20 : 1) and the extract chromatographed on alumina, to yield the isopropylidene derivative of (X); this had  $\lambda_{\max}$ . (relative  $\epsilon$  in parentheses) 2820 (1.0), 2675 (1.27), 2500 (1.17), 2390 (1.29), and 2300 Å (1.40), and  $\nu_{\max}$ . (in CCl<sub>4</sub>) 3546 (OH), 3330 (HC≡C), 2242 (C≡C), 1385 and 1374 (CMe<sub>2</sub>), 1217, 1155, and 1068 cm.<sup>-1</sup>.

Treatment of the isopropylidene derivative with an excess of 2*N*-hydrochloric acid for 2 hr. at 20° and ether-extraction gave (2*D* : 3*L*)-trans-non-4-ene-6,8-diyne-1,2,3-triol (71 mg.) as an oil which rapidly decomposed at 20°,  $[\alpha]_D^{20} -4^\circ \pm 2^\circ$  (*c* 0.8),  $\lambda_{\max}$ . 2800 ( $\epsilon$  12,000), 2650 ( $\epsilon$  16,000), 2510 ( $\epsilon$  11,500), 2385 ( $\epsilon$  7,500), 2260 (infl.,  $\epsilon$  7,000), and 2060 Å ( $\epsilon$  52,000).

The enediyne triol (X; 10 mg.) in methanol (20 c.c.) was hydrogenated over pre-reduced 5% palladium-charcoal at 21°, the uptake of hydrogen (6.14 c.c. at N.T.P.) corresponding to 4.92 moles/mole. The product, obtained by extraction with ether, was an oil which crystallised on storage. Trituration with ether-hexane gave (2*D* : 3*L*)-nonane-1,2,3-triol (6 mg.),  $[\alpha]_D^{20} +8^\circ \pm 3^\circ$  (*c* 0.6), m. p. and mixed m. p. 93—95° (identical infrared spectrum).

trans-Hept-2-ene-4,6-diynal.—An aqueous solution (10 c.c.) of the triol (X) (8 mg.) containing a few drops of methanol was shaken in the dark with periodic acid dihydrate (20 mg.) for 2 hr. Dilution with water and ether-extraction gave *trans*-hept-2-ene-4,6-diynal,  $\lambda_{\max}$ . (relative  $\epsilon$  in parentheses) 3010 (1.0), 2805 (1.63), 2640 (1.79), 2500 (1.42), 2370 (infl., 1.37), and 2200 Å (2.33),  $\nu_{\max}$ . 3300 (HC≡C), 2755 (aldehydic CH), 1698 (conjugated CH=O), 1112 (*trans*-CH=CH=O), and 954 cm.<sup>-1</sup> (*trans*-CH=CH).

#### Acidic Fraction (C).

Methyl *trans*-Dec-2-ene-4,6,8-triynoate.—The total acids, containing enediyne (*ca.* 52 mg.) and enediyne (*ca.* 117 mg.) components were esterified with 5% sulphuric acid in methanol, and the neutral fraction was chromatographed [chromatogram (b)] from light petroleum-benzene (10 : 1) on alumina (50 g.). Initial fractions eluted with the same solvent gave methyl

*trans*-dec-2-ene-4,6,8-triynoate (20 mg.) as needles, m. p. and mixed m. p. 104—106° (decomp.) from dichloromethane-hexane. Ultraviolet and infrared spectroscopic data were identical with those of an authentic sample and those recorded.<sup>2</sup> Hydrogenation gave methyl decanoate, identified by gas-liquid chromatography.

*Methyl 4-Hydroxyundeca-5,6-diene-8,10-diynoate (Methyl Nemotinate)*.—A fraction eluted [chromatogram (b)] with benzene-ether (1:1) gave an oil (70 mg.) which yielded methyl 4-hydroxyundeca-5,6-diene-8,10-diynoate as unstable crystals, m. p. < 0°,  $[\alpha]_D^{17} + 295^\circ$  (c 1.6), after repeated crystallisations at low temperature. Infrared and ultraviolet spectroscopic data were identical with those recorded.<sup>10</sup>

Isomerisation with 0.1N-sodium hydroxide gave methyl isonemotinate (correct infrared and ultraviolet spectra), and hydrogenation over 5% palladium-charcoal followed by micro-distillation (b. p. 160—163°/13 mm.) gave  $\gamma$ -undecanolactone with an infrared spectrum identical with that of synthetic ( $\pm$ )-material.

*Methyl Nona-3,4-diene-6,8-diynoate*.—A fraction from chromatogram (b), immediately preceding that containing methyl nemotinate, contained methyl nona-3,4-diene-6,8-diynoate (20 mg.) which was not obtained crystalline even at -70°. The material gave infrared and ultraviolet spectra identical with those of a synthetic sample (see above), except for a weak band in the infrared at 3470 cm.<sup>-1</sup> indicating a trace of methyl nemotinate as impurity. Treatment of the ester (10 mg.) with N-sodium hydroxide for 2 days at 20° gave a triyne acid (5 mg.),  $\lambda_{\max}$ . 2090 Å. Hydrogenation over 10% palladium-charcoal gave methyl nonanoate, identified by gas-liquid chromatography.

#### Coprinus quadrifidus (see Part IX ?).

(2D:3D)-*Non-4-ene-6,8-diyne-1,2,3-triol* (XVI).—The polar enediyne was isolated as before<sup>7</sup> and was redistributed between M/15-potassium dihydrogen phosphate and ether for 50 transfers to ensure homogeneity. Quantitative data for the compound was obtained by carrying out measurements on aliquot portions of ethanolic solutions and weighing the residue after evaporation to dryness in tared flasks. (2D:3D)-*Non-4-ene-6,8-diyne-1,2,3-triol* had  $[\alpha]_D^{20} + 2^\circ$  (c 1.2),  $\lambda_{\max}$ . 2805 ( $\epsilon$  12,000), 2650 ( $\epsilon$  15,500), 2510 ( $\epsilon$  11,000), 2385 ( $\epsilon$  7000), 2270 (infl.,  $\epsilon$  4000), and 2080 Å ( $\epsilon$  38,000).

The triol (30 mg.) was heated under reflux with toluene-*p*-sulphonic acid (50 mg.) in dry acetone (20 c.c.) for 8 hr. Excess of sodium carbonate was added to the cooled solution, and the mixture kept at 20° for 4 hr. and then filtered, and the solvent evaporated at 0° at 20 mm. The residue was extracted with light petroleum (b. p. 40—60°; 5 × 15 c.c.) and the combined extracts were chromatographed on alumina. Fractions eluted with light petroleum-ether (20:1) had  $\lambda_{\max}$ . (in ether) (relative  $\epsilon$  in brackets) 2805 (1.0), 2660 (1.12), 2510 (0.97), and 2390 Å (0.90);  $\nu_{\max}$ . 3571 (OH), 3401 (OH), 3300 (HC≡C), 2222 (C≡C), and 958 cm.<sup>-1</sup> (*trans*-CH=CH). The product was probably a mixture of the 1,2- and 2,3-isopropylidene derivatives since the infrared spectrum showed both primary and secondary hydroxyl stretching bands at 1058 and 1110 cm.<sup>-1</sup>, respectively.

Oxidation of the triol (ca. 18 mg.) in aqueous solution (20 c.c.) containing a few drops of methanol, with excess of periodic acid dihydrate in the dark for 12 hr. gave a product with ultraviolet and infrared spectral data identical to those recorded for *trans*-hept-2-ene-4,6-diyne-1 (see above).

(2D:3D)-*Nonane-1,2,3-triol*.—The enediynetriol (100 mg., estimated spectroscopically) in methanol (20 c.c.) was hydrogenated over pre-reduced 10% palladium charcoal at 18° and atmospheric pressure for 4 hr. The uptake of hydrogen was 69.1 c.c. at N.T.P. corresponding to 5.1 mol. Crystallisation of the product from ether gave (2D:3D)-nonane-1,2,3-triol (110 mg.), m. p. 103—104°,  $[\alpha]_D^{21} + 19^\circ$  (c 1.6) (Found: C, 61.2; H, 11.3. Calc. for C<sub>9</sub>H<sub>20</sub>O<sub>3</sub>: C, 61.3; H, 11.4%). The m. p. was undepressed by a sample,  $[\alpha]_D^{21} + 18^\circ$ , prepared by hydrogenation of the triynetriol (XIV), and the infrared spectra were identical.

The tribenzoate (Found: C, 73.7; H, 6.7. Calc. for C<sub>30</sub>H<sub>32</sub>O<sub>6</sub>: C, 73.75; H, 6.6%) had  $[\alpha]_D^{21} - 35^\circ$ , m. p. and mixed m. p. 93—94°, and infrared spectrum identical with that previously reported.<sup>7</sup>

*1-Hydroxydec-2-ene-4,6,8-triyn-9-al* (XVII).—The hydroxy-aldehyde (ca. 2.5 mg., estimated spectroscopically), isolated as before<sup>7</sup> had  $\lambda_{\max}$ . (in ether) (relative  $\epsilon$  in brackets) 3510 (1.0), 3280 (1.2), 3060 (1.0), 2900 (0.78), and 2740 Å (0.70).

The fraction (ca. 2 mg.) in dry ether (5 c.c.) was treated with an excess of lithium aluminium

hydride at 20° for 30 min. Excess of reagent was decomposed with water, and the mixture acidified and extracted with ether (2 × 5 c.c.) to yield a solution with  $\lambda_{\max}$ . (in ether) (relative  $\epsilon$  in brackets) 3140 (1.0), 2950 (1.10), 2780 (0.95), 2630 (0.65), 2490 (1.08), and 2450 Å (inf. 1.04). An authentic sample of *trans,trans*-deca-2,8-diene-4,6-diyne-1,10-diol was unaffected under the above reaction conditions.

This product in methanol (5 c.c.) was hydrogenated over 10% palladium charcoal for 6 hr. The perhydro-derivative (1.2 mg.) had m. p. 65—69°, undepressed on admixture with decane-1,10-diol (m. p. 70—71°). Conversion into the dimethyl ether by Purdie's method gave a trace of oil, identified as 1,10-dimethoxydecane by comparative gas-liquid chromatography.

The authors are indebted to the Rockefeller Foundation for financial assistance, to the University of Oxford for a Pressed Steel Research Fellowship (R. C. C.), to the U.S. National Institute for Health for a Research Fellowship (A. H.), and to Mr. J. W. Keeping for the mycological work.

THE DYSON PERRINS LABORATORY, OXFORD UNIVERSITY.

[Received, January 25th, 1963.]

---