

Crystal and Molecular Structure of 7-Oxabicyclo[2,2,1]hept-5-ene-2,3-*exo*-dicarboxylic Anhydride

By **S. Baggio**,* Facultad de Farmacia y Bioquímica, Universidad de Buenos Aires y C.N.E.A., Buenos Aires, Argentina

A. Barriola, Escuela de Química, Universidad Central, Caracas, Venezuela

P. K. de Perazzo, Departamento de Radiaciones Atómicas y Moleculares, Comisión Nacional de Energía Atómica, Buenos Aires, Argentina

The crystal and molecular structure of the title compound (I) has been determined by three-dimensional X-ray analysis from 750 non-zero reflexions measured photographically. The compound crystallizes in the orthorhombic system, space group $P2_12_12_1$ with $a = 7.00 \pm 0.02$, $b = 18.93 \pm 0.03$, and $c = 5.38 \pm 0.01$ Å, $Z = 4$. The crystal structure has been solved by the symbolic addition procedure applied to non-centrosymmetric crystals, and refined by least-squares calculations to R 0.087. The compound has the *exo*-conformation. The introduction of an oxygen atom in position 7 of the norbornene skeleton produces interesting modifications in some bond distances and angles.

THE structural study of molecules with internal strain has been quite extensive. Among these molecules, polycyclic hydrocarbons and their derivatives have been the object of several investigations through electron and X-ray diffraction analysis.¹⁻¹⁰

At the same time, several techniques of semi-empirical calculations for the determination, *a priori*, of molecular geometry have been developed and applied.¹¹ For further application of these methods, precise structural data on some additional compounds of this type is desirable.

¹ Y. Morino, K. Kuchitsu, and A. Yokozeki, *Bull. Chem. Soc. Japan*, 1967, **40**, 1552.

² N. C. Baenziger, J. R. Doyle, and C. L. Carpenter, *Acta Cryst.*, 1961, **8**, 924.

³ G. Ferguson, C. J. Fritchie, J. M. Robertson, and G. A. Sim, *J. Chem. Soc.*, 1961, 1976.

⁴ D. A. Bruechner, T. A. Hamer, J. M. Robertson, and G. A. Sim, *J. Chem. Soc.*, 1962, 799.

⁵ F. Cesur and D. F. Grant, *Acta Cryst.*, 1965, **18**, 55.

⁶ N. C. Baenziger, G. F. Richards, and J. R. Doyle, *Acta Cryst.*, 1965, **18**, 924.

We have therefore determined the structure of 7-oxabicyclo[2,2,1]hept-5-ene-2,3-*exo*-dicarboxylic anhydride (I). This compound, obtained by the Diels-Alder re-

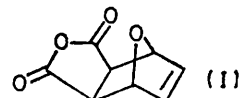

action between furan and maleic anhydride, has the additional feature of being one of the very few exceptions to the Alder-*endo*-addition rule, for reactions in which such a distinction may be drawn.¹²

⁷ A. C. Macdonald and J. Trotter, *Acta Cryst.*, 1965, **18**, 243.

⁸ A. C. Macdonald and J. Trotter, *Acta Cryst.*, 1965, **18**, 456.

⁹ R. Restro, C. M. Gramaccioli, and M. Simonetta, *Chem. Comm.*, 1968, 568.

¹⁰ R. Restro, G. Filippini, C. M. Gramaccioli, and M. Simonetta, *Acta Cryst.*, 1969, **B25**, 2465.

¹¹ J. E. Williams, P. J. Stang, and P. von R. Scheleyer, *Ann. Rev. Phys. Chem.*, 1968, **10**, 531.

¹² R. B. Woodward and H. Baer, *J. Amer. Chem. Soc.*, 1948, **70**, 1161.

EXPERIMENTAL

Crystals of (I) were obtained from the reaction of furan and maleic anhydride in ether, at room temperature, as prisms, elongated along c .

The cell dimensions were obtained from calibrated zero-level precession photographs, taken with Mo- K_α radiation, $\lambda = 0.7107 \text{ \AA}$.

Crystal Data.— $C_8H_6O_4$, $M = 166.08$, Orthorhombic, $a = 7.00 \pm 0.02$, $b = 18.93 \pm 0.03$, $c = 5.38 \pm 0.01 \text{ \AA}$, $U = 712.7 \text{ \AA}^3$, $D_m = 1.58 \pm 0.02$ (by flotation) $Z = 4$, $D_c = 1.56$, $F(000) = 344$. Space group, $P2_12_12_1$, from systematic absences: $h00, 0k0, 00l$ with h, k, l odd respectively. Cu- K_α radiation (for intensity measurement), $\lambda = 1.5418 \text{ \AA}$; $\mu(\text{Cu-}K_\alpha) = 11.2 \text{ cm}^{-1}$.

Structure Determination.—Intensity data were collected from equi-inclination integrated Weissenberg photographs by the multiple-film method. The layers 0—4 along a and 0—4 along c were recorded from two crystals, almost square in section whose diameters were *ca.* 0.4 mm. The intensities of 750 non-zero reflexions were recorded of which 612 were independent, and were measured on a microdensitometer. Lorentz and polarization corrections were applied, and no correction was made for absorption.

Solution and Refinement of the Structure.—The structure of the compound was solved by the statistical method using the general method for non-centrosymmetric structures of Karle and Karle.¹³

The normalized structure factor magnitudes $|E|$ were computed and the values of the statistical averages for $\langle |E| \rangle$, $\langle |E|^2 \rangle$, and $\langle (|E|^2 - 1) \rangle$ for the non-centrosymmetric reflexions were 0.822, 0.924, and 0.780, as compared with 0.886, 1.000, and 0.732, the theoretical values for the non-centrosymmetric space groups.

In space group $P2_12_12_1$, there are eight possible origins and two enantiomorphs, giving sixteen equivalent combinations of phases. Generally, origin and enantiomorph are isolated by fixing the phase of four two dimensional reflexions of suitable parity among the strongest $|E|$.

In this compound, there are few two-dimensional reflexions with large $|E|$ values. For this, we prefer to restrict the phase of an hkl reflection to the range $0-\pi$ in order to fix the enantiomorph. The initial assignment is listed in

h	k	l	$ E $	ψ
0	1	5	2.19	$\pi/2$
5	0	4	1.95	0
0	19	2	1.92	$\pi/2$
3	8	1	2.25	$0 \leq b \leq \pi$

Table 1. Equation (1) was used to start the phase determination.

$$\psi_h \simeq \langle \psi_k + \psi_{h-k} \rangle kr \quad (1)$$

After the application of equation (1) a set of 21 self-consistent phases of reflexions with $|E| > 1.5$ were obtained, many of them as a function of symbol b . Some relationships indicated that b could be 0, $\pi/2$, or π . In view of this inconsistency, no assumption was made about the value of b in applying the tangent formula equation (2).

$$\tan \psi_h \simeq \frac{\langle |E_k E_{h-k}| \sin(\psi_k + \psi_{h-k})k \rangle}{\langle |E_k E_{h-k}| \cos(\psi_k + \psi_{h-k})k \rangle} \quad (2)$$

In order to apply (2), numerical values were assigned to the phases, phasing the b symbol from 0 to π in steps of

$\pi/4$. The calculation with $b = 3\pi/4$ gave the lower R_K ¹³ value, 0.14, and it was proved to be the correct solution when the Fourier map with the 155 phased reflexions with $|E| > 1.30$ was computed. The twelve atoms other than hydrogen, of the asymmetric unit, appeared clearly in the map as the strongest peaks, with relative intensities between 999 and 417; the intensity of the highest spurious peak being 261.

At this point, a sequence of full-matrix least-squares refinement cycles was begun, allowing for the simultaneous variation of co-ordinates, isotropic temperature factors, and individual scale factors, one for each of the registered layers. During this step of refinement we used all the measured intensities along the two crystal orientations. After five cycles, the residual R was reduced from 0.270 to 0.122. The common intensities were now averaged and only one overall scale factor was used in the anisotropic refinement. Convergence was achieved with R 0.103 and R' 0.133 [$R' = \Sigma(\omega\Delta^2)/\Sigma\omega F_o^2$]. The weighting scheme used in the last stages of the refinement was $\sigma = SQR(T(A + B|F_o|)(C + D \cdot \sin^2 \theta/\lambda^2))$; where constants were modified from cycle to cycle in order to obtain a fairly constant average value of $\omega\Delta^2$ in ranges of $\sin \theta$ and $|F_o|$. The final values were $A = 0.50$, $B = 0.15$, $C = 0.60$, and $D = -7.0$.

As data were not of sufficient accuracy to warrant the location of hydrogen atoms, we prefer to calculate the theoretical positions and include them in the structure factor calculation with fixed co-ordinates and isotropic temperature factors ($B = 3.5 \text{ \AA}^2$). The final R and R' were 0.087 and 0.120 respectively. The form factors for carbon, oxygen, nitrogen, and hydrogen were taken from ref. 14.

RESULTS AND DISCUSSION

The final parameters for non-hydrogen atoms are listed in Table 2; the theoretical co-ordinates for hydrogen

TABLE 2

Final parameters with standard deviations in parentheses
For numbering of atoms see Figure 1

(a) Fractional co-ordinates			
Atom	x/a	y/b	z/c
O(1)	-0.1988(18)	0.0587(4)	0.1917(14)
O(2)	-0.4260(11)	0.1387(4)	0.1317(21)
O(3)	0.0548(13)	-0.0109(4)	0.1644(21)
O(7)	0.0746(8)	0.1800(3)	-0.0149(11)
C(1)	-0.0795(13)	0.1959(4)	-0.1843(20)
C(2)	-0.1816(10)	0.1223(3)	-0.1846(16)
C(3)	-0.0102(13)	0.0727(4)	-0.1748(19)
C(4)	0.1574(11)	0.1249(4)	-0.1603(20)
C(5)	0.1711(15)	0.1570(5)	-0.4148(20)
C(6)	0.0176(15)	0.2035(5)	-0.4328(20)
C(8)	-0.2839(12)	0.1103(5)	0.0515(21)
C(9)	-0.0367(14)	0.0347(4)	0.0660(20)

(b) Anisotropic thermal parameters ($\times 10^4$)						
	β_{11}	β_{22}	β_{33}	β_{12}	β_{13}	β_{23}
O(1)	189(27)	26(3)	200(47)	-1(10)	-12(33)	19(12)
O(2)	197(27)	55(5)	658(77)	-31(11)	-62(39)	-32(19)
O(3)	357(39)	39(4)	650(80)	-26(13)	-15(50)	-28(18)
O(7)	114(18)	11(2)	196(38)	6(6)	-13(25)	6(8)
C(1)	112(28)	9(3)	250(56)	19(10)	-78(35)	20(13)
C(2)	66(30)	8(3)	157(44)	8(10)	-63(28)	15(12)
C(3)	122(26)	17(3)	207(55)	-1(10)	27(37)	-2(14)
C(4)	81(25)	17(3)	259(65)	6(10)	-11(36)	5(16)
C(5)	164(34)	25(4)	146(58)	-9(13)	36(43)	18(16)
C(6)	178(36)	17(3)	192(60)	-3(11)	-21(45)	22(16)
C(8)	122(29)	28(4)	295(73)	-12(12)	-37(41)	4(17)
C(9)	116(30)	16(3)	391(70)	22(11)	-17(47)	-29(14)

¹³ J. Karle and I. Karle, *Acta Cryst.*, 1966, **21**, 849.

¹⁴ D. T. Cromer and J. T. Waber, *Acta Cryst.*, 1965, **18**, 104.

atoms are given in Table 3 and the observed and calculated structure factors computed with those parameters

TABLE 3
Parameters for the hydrogen atoms

	<i>x</i>	<i>y</i>	<i>z</i>
H(1)	-0.173	0.241	-0.132
H(2)	-0.272	0.114	-0.348
H(3)	-0.001	0.037	-0.336
H(4)	0.294	0.104	-0.088
H(5)	0.300	0.150	-0.652
H(6)	-0.029	0.235	-0.598

are listed in Supplementary Publication No. SUP 20358 (4 pp., 1 microfiche).*

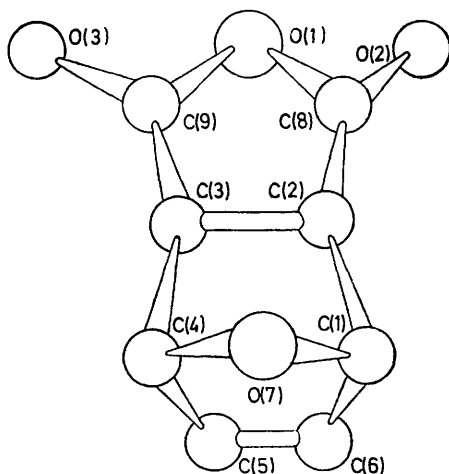

FIGURE 1 A view of the molecule, showing the numbering system used

The molecule has the *exo*-conformation and Figure 1 shows a schematic view. Figure 2 shows a projection of the structure on the plane (001).

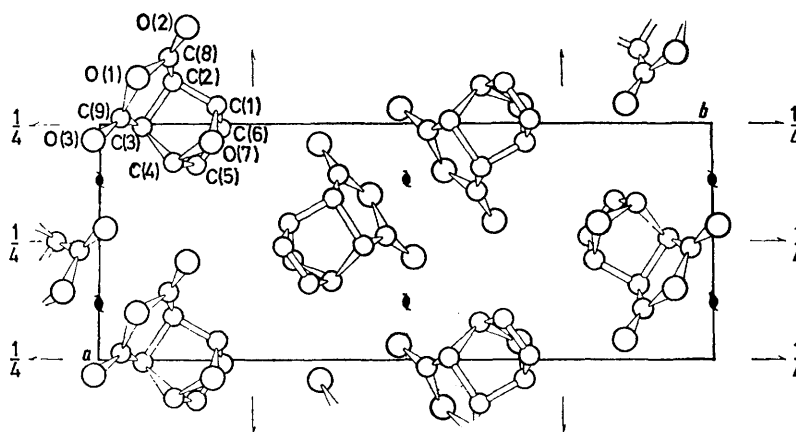

FIGURE 2 Projection of the structure on the plane (001)

The equations of some planes in the molecule are given in Table 4, together with interplanar angles and the

* For details see Notice to Authors No. 7 in *J. Chem. Soc. (A)*, 1970, Issue No. 20. (items less than 10 pp. are supplied as full-page copies).

distances of relevant atoms from the planes; these distances are all $< 2\sigma$.

TABLE 4

Equations of best least-squares planes in the form $Ax + By + Cz = D$. Distances (Å) of the atoms from the planes are given in square brackets

Plane (A): $-0.5563x - 0.6987y - 0.4499z = -0.4784$

[C(2) 0.018(8), C(3) -0.016(10), C(8) -0.002(10), C(9) 0.004(10), O(1) 0.017(8), O(2) -0.015(8), O(3) -0.006(8)]

Plane (B): $0.0557x - 0.0118y - 0.9984z = 0.9047$

[C(1) 0.010(12), C(2) -0.015(10), C(3) 0.015(11), C(4) -0.011(12)]

Plane (C): $-0.5693x + 0.7369y - 0.3645z = -2.0489$

[C(1) 0.000(10), C(4) 0.000(10), C(5) -0.001(11), C(6) 0.001(10)]

Plane (D): $0.5815x + 0.6719y - 0.4582z = 2.6180$

Dihedral angles (deg.)

(A)-(B)	120.0	C-D	131.3
(B)-(C)	114.6	B-D	114.2

Dihedral angles (Table 4) are in good agreement with those found in compounds having similar skeleton. Plane (D) does not bisect the angle between planes (B) and (C). A tentative explanation for this might be the repulsive effect between the π -electrons of the C(5)-C(6) double bond and non-bonding *p* electrons of the oxygen atom O(7).

The intermolecular distances and angles with their estimated standard deviations are reported in Table 5. Owing to the *m* symmetry of the isolated molecule there are various bonds and angles which are equivalent. In all cases these distances and angles differ by $< 3\sigma$.

It is worth while to compare the geometry of our compound with that of norborn-5-ene-2,3-dicarboxylic anhydride,¹⁰ a closely related compound where position 7 is occupied by a tetrahedral carbon atom. The presence of an oxygen atom in position 7 of the norbornene

skeleton produces some modifications in distances and angles, since the distance C-O is considerably shorter than C-C. The major effects are observed in distances and angles involving the C(5) and C(6) atom (Table 6).

The diminution of angles C(4)-C(5)-C(6) and C(1)-

C(6)-C(5) in our compound might account for the considerable lengthening of the C(5)-C(6) distance (1.392 against 1.340 Å in the norborn-5-ene derivative).

TABLE 5
Bond distances and angles

(a) Distances (Å)			
O(7)-C(1)	1.443(12)	C(8)-C(2)	1.476(15)
O(7)-C(4)	1.430(12)	C(2)-C(1)	1.566(15)
O(2)-C(8)	1.210(14)	C(4)-C(3)	1.536(15)
O(3)-C(9)	1.212(15)	C(5)-C(4)	1.501(17)
O(1)-C(9)	1.397(14)	C(6)-C(1)	1.507(16)
O(1)-C(8)	1.370(14)	C(2)-C(3)	1.524(13)
C(9)-C(3)	1.493(16)	C(5)-C(6)	1.392(16)
(b) Angles (deg.)			
C(4)-O(7)-C(1)	96.2(0.7)	O(7)-C(1)-C(2)	99.0(0.7)
C(9)-O(1)-C(8)	108.6(0.8)	O(7)-C(1)-C(6)	104.1(0.8)
O(1)-C(9)-O(3)	117.8(1.0)	C(2)-C(1)-C(6)	106.9(0.8)
O(1)-C(9)-C(3)	111.4(0.9)	C(1)-C(6)-C(5)	103.1(0.9)
O(3)-C(9)-C(3)	130.8(1.1)	C(6)-C(5)-C(4)	105.7(0.9)
O(2)-C(8)-O(1)	118.5(1.0)	O(7)-C(4)-C(5)	103.3(0.8)
O(2)-C(8)-C(2)	129.6(1.0)	O(7)-C(4)-C(3)	100.8(0.8)
O(1)-C(8)-C(2)	111.9(0.9)	C(5)-C(4)-C(3)	105.2(0.8)
C(8)-C(2)-C(1)	110.9(0.8)	C(9)-C(3)-C(2)	103.2(0.8)
C(8)-C(2)-C(3)	104.9(0.8)	C(9)-C(3)-C(4)	111.1(0.8)
C(1)-C(2)-C(3)	100.9(0.7)	C(2)-C(3)-C(4)	101.9(0.8)

The anhydride group is planar, and its geometry is in close agreement with the results obtained for succinic anhydride and related compounds.¹⁵

All the intermolecular contacts correspond to van der

Waals interactions. Assuming that the van der Waals radii¹⁶ for carbon and oxygen are 1.8 and 1.4 Å respectively, only in two cases are distances between atoms of different molecules less than the sum of the

TABLE 6

		Norborn-5-ene-2,3-dicarboxylic anhydride	
		(I)	
		Mean value	Mean value
C(2)-C(3)-C(4)		101.5°	103.0°
C(3)-C(2)-C(1)			
C(2)-C(3)-C(5)		106.6	107.3
C(2)-C(1)-C(6)			
C(4)-C(5)-C(6)		104.3	107.4
C(1)-C(6)-C(5)			
C(4)-O(7)-C(1)		96.2	C(4)-C(7)-C(1) 93.4

corresponding van der Waals radii: O(7) ··· C(6) ($x, y, z + 1$) 3.18(1) and O(3) ··· C(4) ($\frac{1}{2} - x, -y, \frac{1}{2} + z$) 3.08(1) Å.

We thank Drs. F. Ahmed, B. Foxman, M. E. Pippy, C. T. Prewitt, A. Zalkin, and L. N. Becka for making available the Fortran IV programs used in the calculations.

[2/020 Received, 5th January, 1972]

¹⁵ M. Ehrenberg, *Acta Cryst.*, 1965, **19**, 698.

¹⁶ A. I. Kitaigorodskii, 'Organic Crystallography,' Consultants Bureau, New York, 1961, English edn. p. 7.