

### s-Triazines. Part IV.† Kinetic and $pK_a$ Studies of 2,4-Dichloro-6-(*N*-methylpyrrol-2-yl)-s-triazine and its Hydrolysis Products

By Anthony F. Cockerill,\* Geoffrey L. O. Davies, and David M. Rackham, Lilly Research Centre Limited, Erl Wood Manor, Windlesham, Surrey

The kinetics of hydrolysis of the title dichloro-s-triazine (I) and its 2-oxo-analogue (II) have been measured by u.v. absorption spectroscopy and pH-stat methods in the pH/ $H_0$  range 12.3 to -5.7.  $pK_a$  Data for (II) and the 2,4-dioxo-analogue (III) are compared with those for the analogous hydrolysis products of cyanuric chloride. Rate coefficients for the attack of hydroxide and water on (I) and (II), together with the  $pK_a$  values of the substrates, can be used to rationalise the observed rate profiles. This leads to an interpretation of the mechanism of hydrolysis of (I) and (II) in terms of rate-determining nucleophilic attack on an electron-deficient carbon atom without the intervention of a previously suggested hydrated intermediate.

2,4,6-TRIHALOGENO-s-TRIAZINES and their derivatives have attracted considerable recent interest as herbicides, reactive dyes, optical brighteners, and additives for improving the thermal stability of nylon.<sup>1</sup> It is well known that the cyanuric halides are very sensitive towards water,<sup>2</sup> yet there are comparatively few kinetic studies concerning their mechanism of hydrolysis.<sup>3-5</sup>

Koopman<sup>3</sup> reported the hydrolysis coefficients for the replacement of the first chlorine atom in a series of 2-aryl-4,6-dichloro-s-triazines in aqueous acetone. He found that the rate coefficient increased with the electron-withdrawing power of the substituent in the aryl group, a Hammett reaction constant of 1.33 being noted. Horrobin<sup>4</sup> studied the influence of pH on the hydrolysis of cyanuric chloride and a number of 2-substituted cyanuric chlorides. He concluded that the reaction proceeds in a stepwise manner and involves nucleophilic attack on an electron-deficient carbon atom,

† Part III, J. K. Chakrabarti and D. E. Tupper, *J. Heterocyclic Chem.*, submitted for publication.

<sup>1</sup> (a) D. E. Armstrong, G. Chesters, and R. F. Harris, *Proc. Soil Sci. Soc. America*, 1967, **31**, 61; (b) H. P. Burchfield and E. E. Storrs, *Contr. from Boyce Thompson Inst.*, 1956, **18**, 395; (c) F. W. Ayscough and I. N. Simpson, *Austral. J. Chem.*, 1971, **24**, 2649.

via an  $A_N2E$  process. The relative rates of displacement of the first and second chlorine atoms depend markedly on the pH of the medium (Scheme 1). In

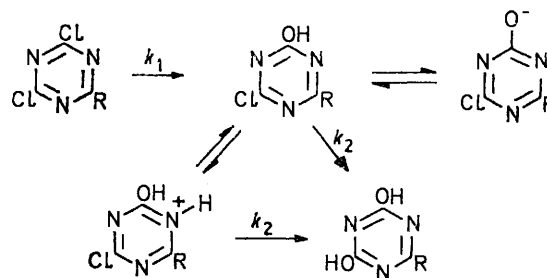

SCHEME 1

acidic solution (pH 0–2),  $k_2 > k_1$ , whereas in alkaline solution (pH 8–12),  $k_2 < k_1$ . The two steps proceed at comparable rates in the intermediate pH region (pH 3–7). These variations can be explained in terms of

<sup>2</sup> (a) A. F. Maxwell, J. S. Fry, and L. A. Bigelow, *J. Amer. Chem. Soc.*, 1958, **80**, 548; (b) G. Illuminati, *Adv. Heterocyclic Chem.*, 1964, **3**, 285.

<sup>3</sup> H. Koopman, *Rec. Trav. chim.*, 1962, **81**, 465.

<sup>4</sup> S. Horrobin, *J. Chem. Soc.*, 1963, 4130.

protonation and deprotonation behaviour of the intermediate mono-oxo-compound.

Rys, Schmitz, and Zollinger<sup>5</sup> have recently re-examined the mechanism of replacement of the first chlorine atom in the hydrolysis of cyanuric chloride in aqueous acetone for the pH range 8–12. They assessed the extent of hydrolysis by a pH-stat titration and noted that a plot of log (–OH uptake) against time showed initial curvature, and gradually became a straight line. Subsequent multiple non-linear regression analysis suggested a more complicated mechanism than outlined in Scheme 1 (see Scheme 2), a hydrated form of the cyanuric chloride being included.

The data outlined above are confined to a relatively limited pH variation and the conclusions concerning the mechanism are at variance. In this paper we discuss the mechanism of hydrolysis of 2,4-dichloro-6-(*N*-methylpyrrol-2-yl)-*s*-triazine in aqueous dioxan over the pH/ $H_0$  region 12.3 to –5.7. A later paper will describe the synthesis and hydrolysis of a series of substituted triazines bearing various heterocyclic and halogen substituents. Our mechanistic analysis does not require

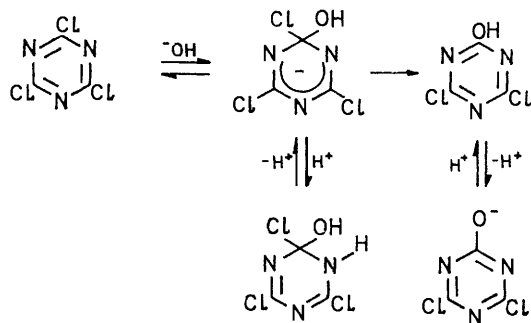

the intermediacy of the hydrate proposed by others,<sup>5</sup> but is consistent with rate-determining formation of the Meisenheimer intermediate in the displacement of the first halogen atom.

#### EXPERIMENTAL

**Preparation of *s*-Triazines.**—2,4-Dichloro-6-(*N*-methylpyrrol-2-yl)-*s*-triazine (I) undergoes successive hydrolyses to give 6-chloro-4-(*N*-methylpyrrol-2-yl)-*s*-triazin-2-one (II) and 6-(*N*-methylpyrrol-2-yl)-*s*-triazine-2,4-dione (III) (Scheme 3). The preparations of (I) and (III) are described elsewhere.<sup>6</sup> Partial hydrolysis of (I) (4.6 g) was achieved on treatment with sodium hydroxide (2.5 equiv.) in acetone–water (140/50 ml) at room temperature. When the chromophore of (I) had disappeared (see later), the reaction was quenched with *n*-HCl (27.5 ml) and the precipitated triazinone (II) was filtered off, washed with water and acetone, and dried *in vacuo*; yield 90% (Found: C, 45.6; H, 3.45; N, 26.8.  $C_8H_7ClN_4O$  requires C, 45.6; H, 3.35; N, 26.7%). Compound (II) showed characteristic spectral differences from (I) and (III), and was easily separated from these by g.l.c.<sup>7</sup>

<sup>5</sup> P. Rys, A. Schmitz, and H. Zollinger, *Helv. Chim. Acta*, 1971, **54**, 163.

<sup>6</sup> J. K. Chakrabarti, R. W. Goulding, and A. Todd, *J.C.S. Perkin I*, 1973, 2499.

**Solvents.**—AnalaR sulphuric acid was used, water was redistilled, and dioxan was purified by distillation from sodium and stored in brown glass bottles in a dry box.

**Buffers and Acidity Functions.**—To ensure complete homogeneity of solution during the entire reaction, all hydrolyses were carried out in 20% (v/v) dioxan–water. A phosphate–citrate–borate buffer<sup>8</sup> was used for the pH range 12.3–2.1, pH being recorded by use of a combination

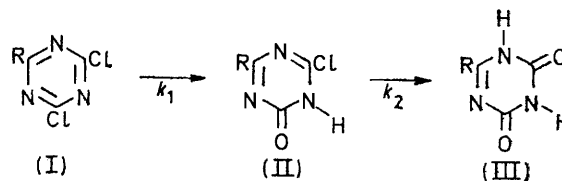

R = *N*-methylpyrrol-2-yl

TABLE I

Indicator <sup>a</sup>	$pK_a$ (20% dioxan–water)	$pK_a$ (water) <sup>b</sup>	$\lambda_{max}/nm$ <sup>c</sup>
(A) <i>N</i> -(4-Nitrophenyl)-piperidine	1.57		419
(B) 4-Nitroaniline	0.35	0.99	380
(C) 2-Nitroaniline	–1.03	–0.29	412
(D) 4-Chloro-2-nitroaniline	–2.13	–1.03	422
(E) 2,5-Dichloro-4-nitroaniline	–2.84	–1.78	370
(F) 2,6-Dichloro-4-nitroaniline	–4.35	–3.27	365

<sup>a</sup> All indicators had satisfactory spectral characteristics and m.p.s in agreement with literature values. <sup>b</sup> Taken from M. J. Jorgenson and D. R. Hartter, *J. Amer. Chem. Soc.*, 1963, **85**, 878; A. I. Biggs and R. A. Robinson, *J. Chem. Soc.*, 1961, 388; K. Yates and H. Wai, *J. Amer. Chem. Soc.*, 1964, **86**, 5408. <sup>c</sup> Wavelength of maximum absorption of the indicator in 20% dioxan–water.

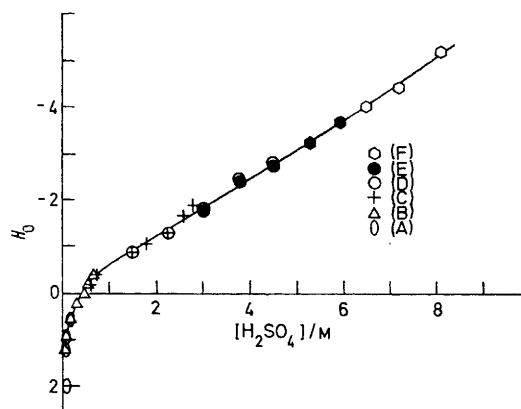

FIGURE 1 Acidity function for 20% v/v dioxan–aqueous sulphuric acid at 30 °C; for indicator designations see Table I

electrode attached to a Corning-EEL pH meter. For the more acidic solutions, an acidity function (nitroaniline indicators) was established. Ionisation ratios ( $[ArNH_3^+]/[ArNH_2]$ ) were measured spectrophotometrically at the wavelength of maximum absorption of the nitroaniline, and  $H_0$  values were calculated from equation (i).<sup>9</sup>

$$H_0 = pK_{ArNH_3^+} - \log \left( \frac{[ArNH_3^+]}{[ArNH_2]} \right) \quad (i)$$

<sup>7</sup> A. F. Cockerill, D. N. B. Mallen, and D. J. Osborne, unpublished results.

<sup>8</sup> T. Teorell and E. Stenhagen, *Biochem. Z.*, 1938, **299**, 416.

<sup>9</sup> F. A. Long and M. A. Paul, *Chem. Rev.*, 1957, **57**, 1.

The acidity function was anchored in the pH region by using the  $pK_a$  value of 1.57 for *N*-(4-nitrophenyl)piperidine. The  $pK_a$  values of the other indicators are listed in Table 1. The absolute values are more negative than the figures reported for aqueous sulphuric acid solutions, but the  $pK$  differences between indicators of adjacent acidity are similar. The variation in  $H_0$  with the molar concentration of sulphuric acid is illustrated in Figure 1.

## RESULTS

(a) *pH-Stat Titrations*.—A number of reactions were followed by using the pH-stat apparatus depicted in Figure 2. The reaction vessel was maintained at

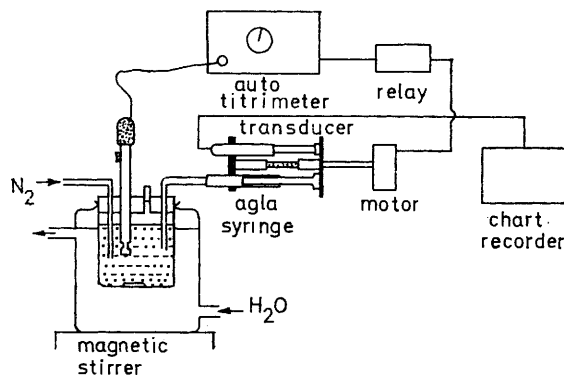

FIGURE 2 pH-Stat apparatus

$30 \pm 0.1$  °C and contained aqueous  $\text{NaClO}_4$  (20 ml), water (12 ml), and dioxan (6 ml), to which a sample of substrate in dioxan (2 ml) was added to initiate the reaction. Curves of titrant consumed (0.1M-NaOH) against time were plotted automatically.

There was no uptake of alkali by (I) during 15 min at pH 4.5 and the u.v. spectrum of the solution remained identical with that of the pure substrate. At pH 8.5, there was a rapid consumption of 2.35 equiv. of alkali, followed by no further change for several hours. However, the blank titre [in the absence of (I)] was 0.35 equiv. Thus, the consumption of 2 equiv. of alkali by the substrate is consistent with its hydrolysis to the mono-oxo-derivative (II), which is then converted into its conjugate base. This deduction was confirmed by quenching the reacted solution in acidic medium, pH 3.08. The spectrum of the solution thus obtained was identical with that of authentic mono-oxo-derivative (II), and, like the latter, changed rapidly into the spectrum of authentic dioxo-compound (III). In a pH-stat titration at pH 10, 2.5 equiv. of alkali were consumed in 1 min, the blank titre being 0.5 equiv.

These results, which are consistent with the previous data of Horrobin for the hydrolysis of cyanuric chloride,<sup>4</sup> indicate that in alkaline solution ( $\text{pH} > 8.5$ ), the first hydrolysis ( $k_1$ ) is much faster than the replacement of the second chlorine atom ( $k_2$ ), but in acidic solution,  $\text{pH} 3-4$ ,  $k_2 > k_1$ .

For the hydrolysis at pH 8.5, a plot of  $\log(-\text{OH uptake})$  against time is slightly curved during the first minute of the titration [Figure 3(A)]. Similar behaviour, reported by others<sup>5</sup> for the hydrolysis of cyanuric

chloride under similar conditions, was attributed to the initial accumulation of a low concentration of a hydrate species, and operation of the mechanism outlined in Scheme 2. However, we feel the curvature in our case arises as a function of our pH-stat system, as we note similar discrepancies from linearity in the hydrolysis of simple  $\gamma$ -lactones, which react at a comparable rate. In these cases, the reaction is limited to ring opening. The departure from linearity could arise from inefficient mixing of the solution in the early stages of reaction.

*U.v. Spectra*.—The u.v. spectra of compounds (I)—(III) are shown in Figure 4. The spectrum of the dichlorotriazine (I) [Figure 4(A)] was invariant over the pH range 11—0. However, in strongly acidic solution, a reversible small bathochromic shift was observed, consistent with the formation of the conjugate acid of (I).

Three distinctly different, but interconvertible spectra were observed for the mono-oxo-derivative (II) [Figure 4(B)]. Alkaline solutions of (II) were prepared by a pH-stat titration of (I) at pH 10—11; aliquot portions of these were then quenched in more acidic aqueous dioxan solutions. The reversible shift of  $\lambda_{\text{max}}$  from 311 to 344 to 375 nm with increased acidity is consistent with the presence of the conjugate base, the un-ionised form, and the conjugate acid of (II). Similar spectral changes were noted for the dioxo-compound (III) [Figure 4(C)], but the actual extinction coefficient of each species is slightly greater than the corresponding value for (II).

*$pK_a$  Determinations*.—The  $pK_a$  values of compounds (I)—(III) and their conjugate acids were calculated from changes in the u.v. spectra with the acidity of the medium (see Table 2). All optical densities used in the

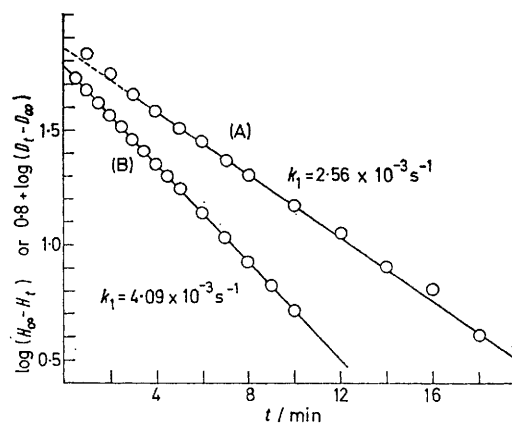

FIGURE 3 (A) pH-Stat titration at pH 8.50;  $H$  refers to the peak height on the recorder, this being a measure of the hydroxide ion consumption. (B) Kinetic run at a buffer pH of 11.3; absorbance ( $D$ ) against time

estimation of ionisation ratios were values obtained by extrapolation to zero reaction time. The logarithm of the ionisation ratio varied linearly with pH or  $H_0$  with a slope approximating to unity except in the case of protonation of the dichlorotriazine (I), for which the slope is about 0.5. Clearly the protonation of this base is not following  $H_0$ , presumably because of a difference in the hydration numbers or variation in the activity

coefficients of the triazine and its conjugate acid, as compared with the nitroanilines and their conjugate acids. Derivatives (II) and (III) are less acidic than the corresponding derivatives of cyanuric chloride ( $R = Cl$ ; Table 2), indicative of the weaker electron-withdrawing power of the *N*-methylpyrrol-2-yl substituent.

TABLE 2

$pK_a$  Values of compounds (I)—(III) in 20% dioxan-water

Equilibrium ( $R = N$ -methylpyrrol-2-yl)	$pK_a^a$	$pK_a$ (CyCl) <sup>b</sup>	$\lambda_{max}/$ nm <sup>c</sup>
	$-3.5^d$		344
	5.2	$< 3^e$	344
	$ca. -1.0^d$		345
	6.7	$3.2^e$	320
	$-1.2^d$		334

<sup>a</sup> In 20% dioxan-water. <sup>b</sup>  $pK_a$  Values of corresponding derivatives of cyanuric chloride in water; *i.e.*  $R = Cl$ . <sup>c</sup> Wavelength at which the extent of ionisation was measured. <sup>d</sup>  $H_0$  Value at half ionisation. <sup>e</sup> From ref. 4.

**Kinetic Analysis by U.v. Spectroscopy.**—For studies of the first displacement ( $k_1$ , Scheme 3), small samples (25  $\mu$ l) of (I) ( $1.1 \times 10^{-3}M$ ) in dioxan were injected into buffer or acidic solutions (2.5 ml) contained in 1 cm silica cells. Rapid mixing was effected (10 s) and the cells were replaced in the thermostatted cell compartment ( $30 \pm 0.1^\circ C$ ) of a Pye-Unicam SP 500, SP 700, or SP 800 spectrophotometer. Rate coefficients,  $k_1$ , were calculated from plots of  $2.303 \log (D_t - D_\infty)$  against time [*cf.* Figure 3(B)] at 344 nm. For runs\* 1–6 (pH 12.3–5.9),  $D_\infty$  values corresponded to the absorption spectrum of (II). For runs 12–14 ( $H_0$  0 to  $-2.1$ )  $D_\infty$  values corresponded to the absorption spectrum of (III), the second displacement occurring much faster than the first. In these two sets of runs,  $D_\infty$  values were taken as the absorbance of reaction solutions at times in excess of 10 half-lives. Runs 7–11 (pH 4.9–1.2) were very slow, and  $D_\infty$  readings were calculated from the spectra of (III). In all cases, the pseudo-first-order plots were linear for at least 50% reaction, and for runs 1–5 and 12–14, in excess of 85% reaction. The lack of curvature in the early stages of reaction at pH 11.3

\* Run figures are indicated on Figure 6.

contrasts with the pH-stat experiments (*cf.* Figure 3). Furthermore, the complete u.v. spectral changes exhibit a sharp isosbestic point, consistent with the presence of

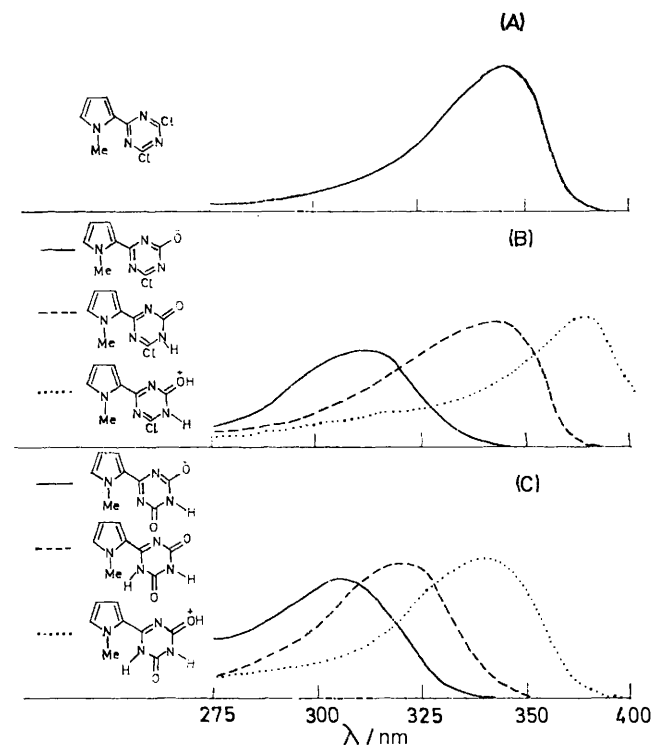

FIGURE 4 U.v. spectra of compounds (I)—(III) in various 20% dioxan-water solutions

(A) pH 9.72	$\epsilon_{max}$ 31,000 at 344 nm
(B) pH 12.3	$\epsilon_{max}$ 21,230 at 311 nm
pH 2.0	$\epsilon_{max}$ 26,400 at 344 nm
$H_0 - 4.0$	$\epsilon_{max}$ 28,800 at 379 nm
(C) pH 8.65	$\epsilon_{max}$ 24,000 at 306 nm
pH 3.90	$\epsilon_{max}$ 28,100 at 319 nm
$H_0 - 5.6$	$\epsilon_{max}$ 30,700 at 339 nm

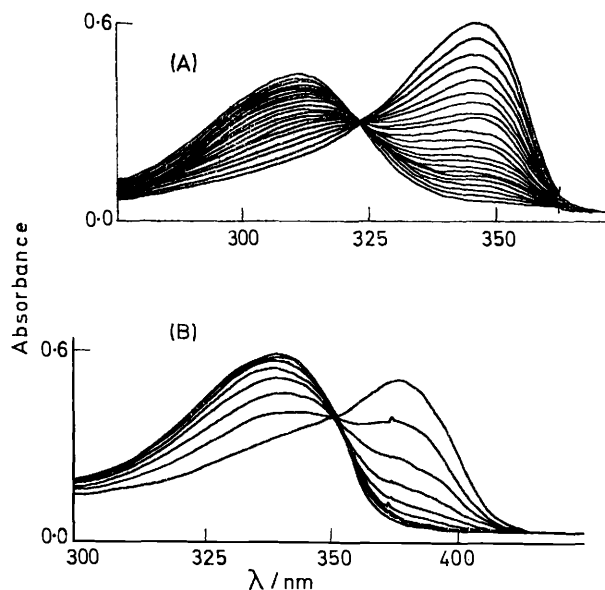

FIGURE 5 U.v. spectral changes showing isosbestic points: (A) (I)  $\rightarrow$  (II) at pH 9.72 and (B) (II)  $\rightarrow$  (III) at  $H_0 - 4.0$ , both in 20% dioxan-water

only (I) and (II) (anion form) in the reaction solution in significant concentrations [Figure 5(A)].

For measurements of the second displacement, samples (15  $\mu$ l) of an alkaline solution (pH *ca.* 11) of (II) ( $3 \times 10^{-3}$ M) were injected into more acidic solutions (2.5 ml). For runs 7–18, by careful selection of the wavelength at which the molar absorbance of (II) and (III) differed most, it was possible to monitor the progress of the reaction directly. A sharp isosbestic point was again observed, consistent with the appearance of only two species in solution [Figure 5(B)], and excellent pseudo-first-order rate plots were obtained. In alkaline solution the spectra of (II) and (III) are very similar and for runs 2–6 at 80 °C it was necessary to quench the reaction mixture [ $5 \times 10^{-4}$ M in (II)] at pH 1.5 (25-fold dilution) to observe significant optical density changes with respect to time.  $D_\infty$  Values were obtained by extrapolation to 10 half-lives.

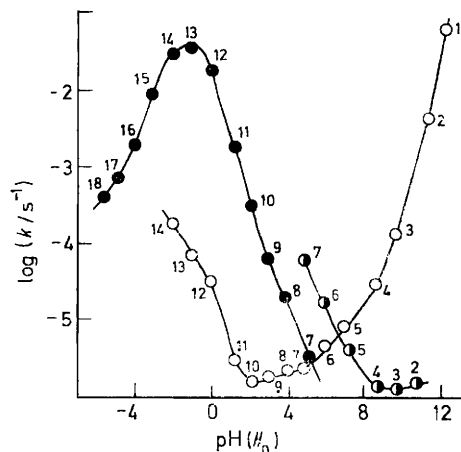

FIGURE 6 Variation in  $k_1$  and  $k_2$  with medium acidity: ○ (I)  $\longrightarrow$  (II) at 30 °C; ● (II)  $\longrightarrow$  (III) at 80 °C

#### DISCUSSION

Figure 6 shows the changes in the observed rate coefficients for the first ( $k_1$ ) and the second ( $k_2$ ) displacements of the chlorine atoms in (I), with pH of the medium. In alkaline solution (pH  $>6.9$ ),  $k_1 > k_2$ , whereas from pH 5.9 to  $H_0 -4$ ,  $k_2 > k_1$ . In stronger acidic solution, it is possible that  $k_1$  exceeds  $k_2$ , but our kinetic dissection was prevented here because of the similarity of the two rate coefficients.

The hydrolysis of (I) to (II) can be expressed by equation (ii), in which  $K_a$  refers to the dissociation constant of the conjugate acid of (I). In the pH region, only the first three terms contribute to the observed rate;  $k_{-OH}$  dominates above pH 8.65,  $\log k_{obs}$  rising with a slope of 1.25 against pH. In the neutral region, pH 8–2, the observed rate reflects the contributions of both  $k_b$  and  $k_{H_2O}$ , a rate minimum being observed near pH 2, due probably to the  $k_{H_2O}$  term alone. Horrobin has shown for the first hydrolysis of cyanuric chloride that the buffer ion catalysis is due to the anions acting as nucleophiles, whereas the parent acids exert no effect on the

observed rate.<sup>4</sup> Thus, from the observed rate coefficients at pH 12.3 and 2, the rate coefficients  $k_{-OH}$  and  $k_{H_2O}$  can be estimated as  $3.2 \times 10^{-1}$  and  $2.3 \times 10^{-8}$  l mol<sup>-1</sup> s<sup>-1</sup>, respectively.

$$\text{rate} = [(I)] \left\{ k_{OH}[\bar{OH}] + k_b[\text{buffer ion}] + k_{H_2O}[H_2O] + k_{H_2O}^+ \frac{[H^+]}{K_a} [H_2O] \right\} \quad (\text{ii})$$

In more strongly acidic solution (pH  $<1$ ), the rate coefficient rises with  $H_0$  as the  $pK_a$  of the conjugate acid of (I) is approached, reflecting specific hydrogen ion catalysis, the rate-determining step involving attack of water on the protonated triazine (I). However, the slope of  $\log k_{obs}$  against  $H_0$  ( $H_0 -0.03$  to  $-2.1$ ) is only 0.38, reflecting the decrease in water activity with increasing acidity and the fact that the protonation of (I) does not follow  $H_0$ . In contrast to our results, it has been reported that the hydrolysis of cyanuric chloride does not respond to acidic catalysis.<sup>2b</sup> In fact, our preliminary experiments with cyanuric chloride indicate a substantial acidic catalysis contribution. The previous workers studied the hydrolysis in media which were too weakly acidic to cause significant protonation of cyanuric chloride.

The mono-oxo-triazine (II) is most unstable in acidic medium of  $H_0 -1$ , the observed rate coefficient decreasing linearly with either a decrease or an increase in acidity of the medium (Figure 6). The position of the maximum falls close to the  $pK_a$  of the conjugate acid of (II). Thus, in more acidic solution, the rate-determining step involves attack of water on the conjugate acid of (II), and the observed decrease in rate is attributable mainly to a decrease in the water activity.

In the pH region, the hydrolysis can involve the conjugate base, uncharged (II), or its conjugate acid. However, the conjugate base is very unreactive towards both  $^-OH$  and  $H_2O$ ; solutions of (II) can be stored for several hours in alkaline media (pH 9–12) without exhibiting changes in the u.v. spectrum. The rise in  $k_{obs}$  as the pH is decreased from 8 is consistent with an increase in the equilibrium concentration of the uncharged (II), on which the nucleophilic displacements involving water or buffer ions occur. With a further decrease in pH, the rate continues to rise as the concentration of the more reactive conjugate acid form of (II) increases. It is interesting that there is no sign of a discontinuity in the  $\log k_{obs}$  vs. pH profile over the pH range 7–1, a result of the fortuitous difference between the two dissociation coefficients of (II). The slope of the profile averages about 0.85 over this section, indicating a buffer ion catalysis contribution between pH 7 and 2, which restricts the calculation of the rate coefficient for the attack of water on (II) from our limited results. However, a rate coefficient of  $5 \times 10^{-3}$  l mol<sup>-1</sup> s<sup>-1</sup> can be estimated for the attack of water on the conjugate acid of (II), assuming this to be the dominant process at pH 1, and the  $pK_a$  of the conjugate acid to be  $-1$ .

A number of reactions were carried out at 80 °C above pH 6, and the results indicate a rate minimum at pH 9. Possibly hydroxide ion attack on the conjugate base of (II) above this pH value may become significant at this elevated temperature.

The observation of the sharp isosbestic point in the u.v. spectra of reaction solutions of (I) converting into (II) at alkaline pH does not accord with the accumulation of significant concentrations of a hydrate intermediate during the displacement process. Such an intermediate would possess a much weaker absorption spectrum than either (I) or (II) (*e.g.* as observed for quinazolines and cinnolines<sup>10</sup>), and this would result in reduced molar absorption of the partly reacted solution as compared with the spectrum observed for the reactant and product. Isosbestic points were observed under most of the

reaction conditions used in both the conversions (I)  $\longrightarrow$  (II) and (II)  $\longrightarrow$  (III). The only exceptions concerned hydrolysis of (I) in strong acid, in which  $k_1$  and  $k_2$  are similar, and consequently the spectral changes reflect simultaneous decomposition of both (I) and (II). Thus, we prefer to interpret the displacements in terms of an  $A_N2E$  mechanism, in which nucleophilic attack on the electron-deficient carbon atom is rate-determining. The leaving group effects and the substituent studies outlined in a later paper support this view

We thank Dr. J. K. Chakrabarti and Mr. D. E. Tupper for the samples of compounds (I) and (III).

[3/2268 Received, 5th November, 1973]

<sup>10</sup> (a) A. R. Osborn, K. Schofield, and L. N. Short, *J. Chem. Soc.*, 1956, 4191; (b) W. L. F. Armarego, *J. Chem. Soc.*, 1962, 561.

---