

## Rearrangements accompanying Oxidative Photoaddition of Nitrosamines to Bicyclo[2.2.1]heptadiene, Cyclo-octa-1,5-diene, and Cyclohexa-1,3-diene

By K. Somasekharen Pillay and Yuan L. Chow,\* Department of Chemistry, Simon Fraser University, Burnaby, British Columbia, Canada V5A 1S6

Oxidative photoaddition of *N*-nitrosodimethylamine to bicyclo[2.2.1]heptadiene, cyclo-octa-1,5-diene, and cyclohexa-1,3-diene gives good yields of aminonitro-oxyalkanes. The allylic nitrate esters derived from cyclohexa-1,3-diene were too unstable to be isolated, but the 1,5-homoallylic adducts to bicyclo[2.2.1]heptadiene were stable nitrate esters and were isolated as the *exo*- and *endo*-isomers. The adducts derived from cyclo-octa-1,5-diene were *cis*- and *trans*-isomers in which the former underwent transannular rearrangement to give oxabicyclic compounds while the latter was stable enough to be isolated as the *trans*-1,2-amino-nitrate ester. The primary photoaddition products are assumed to be the peroxyinitrites which undergo a rapid heterolytic rearrangement. A participation of the transannular  $\pi$ -bond during this heterolytic rearrangement is probably the key step in the formation of the oxabicyclic compounds.

PHOTOLYSIS of a nitrosamine in an acidified solution results in generation of an aminium radical and nitric oxide; the former cation radical efficiently initiates addition to an olefin, leading to a good yield of a 1-amino-2-nitrosoalkane.<sup>1</sup> When the photoaddition is performed under an oxygen atmosphere, the reaction is cleanly diverted to the formation of 1-amino-2-nitro-oxyalkanes.<sup>2,3</sup> In an earlier article we suggested possible mechanisms for the photoaddition, using the addition of *N*-nitrosopiperidine (NNP) and *N*-nitrosodimethylamine to cyclohexene as models.<sup>2</sup> In general, this oxidative photoaddition of nitrosamines gives excellent yields of nitrate esters when simple olefins are used as the substrate.<sup>3</sup> Here we wish to describe the rearrangement that accompanies the photoaddition of a nitrosamine to an olefin.

<sup>1</sup> Y. L. Chow, *Accounts Chem. Res.*, 1973, **6**, 354.

<sup>2</sup> Y. L. Chow, J. N. S. Tam, C. J. Colon, and K. S. Pillay, *Canad. J. Chem.*, 1973, **51**, 2469.

## RESULTS

When a methanol solution of NND and bicyclo[2.2.1]heptadiene containing perchloric acid was irradiated under an oxygen atmosphere, the nitrosamine absorption at 345 nm decreased with clean zero-order kinetics and a clear colourless photolysate was obtained. The major products isolated from the photolysate were *exo*-5-dimethylamino-*endo*-3-nitro-oxytricyclo[2.2.1.0<sup>2,6</sup>]heptane (4a) (10%) and the corresponding *exo*-nitro-oxy-derivative (3a) (40%); the former was readily isolated as its perchlorate salt. The presence of a small amount of the 1,2-adducts (2%), *exo*-3-dimethylamino-*endo*-2-nitro-oxybicyclo[2.2.1]hept-5-ene (2a) and its *exo*-nitro-oxy-isomer (1a), were also detected but were not obtained in the pure state. While the presence of the nitrate and dimethylamino-groups and the cyclopropane ring were readily shown from the spectral

<sup>3</sup> Cf. J. Allen, R. B. Boar, J. F. McGhie, and D. H. R. Barton, *J.C.S. Perkin I*, 1973, 2402; Y. L. Chow, T. Hayasaka, and J. N. S. Tam, *Canad. J. Chem.*, 1970, **48**, 508; Y. L. Chow and J. N. S. Tam, *Chem. Comm.*, 1969, 747.

data, the stereochemistry at the C-3 and C-5 positions could not be elicited from the coupling patterns of the respective protons in (3) and (4).

The stereochemistry of (3) and (4) was clearly established from the corresponding crystalline alcohols (X = H for both) which were obtained by  $\text{LiAlH}_4$  reduction of the nitrates. Oxidation of either alcohols (3b) and (4b) gave the tricyclic ketone (5), proving they are the isomeric pair at the 3-position. The mass spectra of the isomeric alcohols exhibited the same fragmentation pattern but some differences in relative intensity of the peaks. That this isomeric

The proton chemical-shift patterns of the two alcohols induced by a shift reagent, tris(dipivaloylmethanato)europium(III)  $[\text{Eu}(\text{dpm})_3]$ ,\* provides further support to the assigned structure, the results of which are summarised as follows. First, there are linear relationships<sup>8,9</sup> between the chemical shifts of all protons and concentration of  $\text{Eu}(\text{dpm})_3$  on one hand, and the distances of the respective protons from the hydroxy oxygen atom<sup>10,11</sup> on the other. Secondly, the *endo*-alcohol (4b) exhibits a much larger induced shift ( $\Delta\text{Eu}$ ) for the C-5 proton than that for the *syn*-C-7 proton while *exo*-alcohol (3b) is just the opposite,

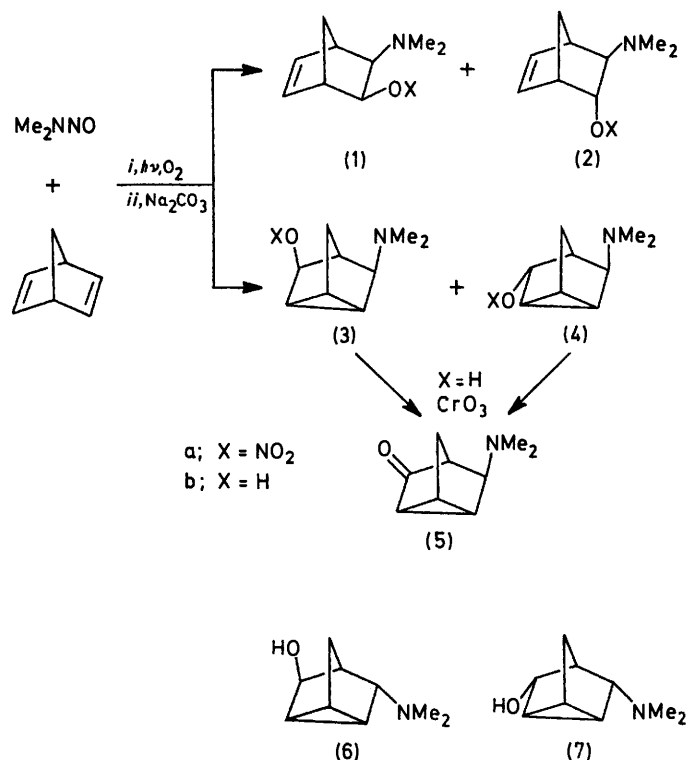

pair of alcohols has the structures (3b) and (4b) but not the alternative ones (6) and (7) (with *endo*-dimethylamino-group) was clarified by the following n.m.r. evidence.

Careful comparison of the n.m.r. spectra of the two alcohols showed that the C-5 proton of (4b) (7.36) was more deshielded by 0.72 p.p.m. than that of (3b) (8.08) and that the *syn*-C-7 proton of (4b) (8.71) was more shielded by 0.51 p.p.m. than that of (3b) (8.20). Since the chemical shifts of other protons were similar for both isomers, the chemical-shift difference for the C-5 and *syn*-C-7 protons must be generated by the electrostatic effects 4–6 of the *endo*- and *exo*-hydroxy-group. Presumably the hydroxy-group induces a positive dipole at the near-by C-5 hydrogen of *endo*-alcohol (4b) and at the *syn*-C-7 hydrogen of *exo*-alcohol (3b). The assignments of n.m.r. signals were confirmed by decoupling experiments.<sup>7</sup>

\* The details of results and experiments on  $\text{Eu}(\text{dpm})_3$ -induced chemical shifts on compounds (3) and (4) are described in ref. 7.

<sup>4</sup> W. H. Urey, Z. L. F. Gaibel, J. C. Dugan, and S. S. Tseng, *J. Amer. Chem. Soc.*, 1973, **95**, 4338.

<sup>5</sup> S. J. Cristol, J. K. Harrington, and M. S. Singer, *J. Amer. Chem. Soc.*, 1966, **88**, 1529.

<sup>6</sup> A. Ferretti and G. Tesi, *J. Chem. Soc.*, 1965, 5203.

*i.e.* the induced shift for *syn*-C-7 protons is much larger than that for the C-5 protons. Finally, the induced-shift difference between *syn*-C-7 and *anti*-C-7 protons is much larger in the *exo*-alcohol (3b) than that in the *endo*-alcohol (4b). These observations, together with those noted above, are consistent with the structures (3) and (4) but not those of (6) and (7). Assuming that the Eu atom co-ordinates with the hydroxy-group,<sup>10,11</sup> the observation is consistent with the *endo*-hydroxy-configuration for (4b) and the *exo*-hydroxy-configuration for (3b).

The oxidative photoaddition of NND to cyclo-octa-1,5-diene proceeded similarly to give a basic fraction which showed strong i.r. absorptions for a nitrate group (1 615, 1 275, and 860  $\text{cm}^{-1}$ ) as well as distinctive n.m.r. signals for olefinic ( $\tau$  4.37) and methoxy ( $\tau$  6.65) protons. Immediate

<sup>7</sup> K. S. Pillay, Ph.D. Thesis, Simon Fraser University, Burnaby, British Columbia, Canada, 1976.

<sup>8</sup> P. V. Demarco, T. K. Elzey, R. B. Lewis, and E. Wenkert, *J. Amer. Chem. Soc.*, 1970, **92**, 5734.

<sup>9</sup> D. J. Trecker and J. P. Henry, *J. Amer. Chem. Soc.*, 1963, **85**, 3204.

<sup>10</sup> R. von Ammon and R. D. Fischer, *Angew. Chem. Internat. Edn.*, 1972, **11**, 675.

<sup>11</sup> C. Beante, Z. W. Wokowski, and N. Thoai, *Tetrahedron Letters*, 1971, 81.

reduction of this fraction followed by chromatography afforded *trans*-2-dimethylaminocyclo-oct-5-en-1-ol (10) (71%), *exo*-6-dimethylamino-*endo*-2-methoxy-9-oxabicyclo-[3.3.1]nonane (11) (12%), and *exo*-5-dimethylamino-*endo*-2-methoxy-9-oxabicyclo[4.2.1]nonane (12) (8%). The n.m.r. signals of the alcohol (10) were investigated by spin-decoupling experiments and their patterns and assignments were confirmed, some by comparisons with computer-simulated patterns.\* The C-1 proton was vicinally coupled to the C-2 proton with  $J = 9$  Hz, the magnitude of which suggested that they were in a nearly *anti*-orientation. Together with their coupling patterns with the C-3 and C-8 vicinal protons, this led us to assign the *trans*-configuration.

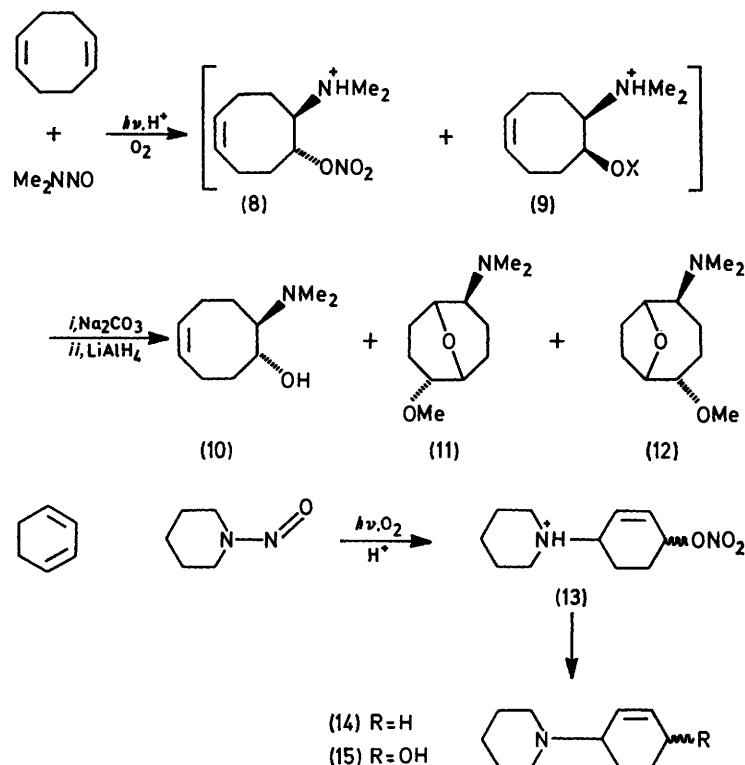

The oxabicyclic compounds, (11) and (12), exhibited no spectral data characteristic of an olefinic bond, but the presence of a methoxy-group was indicated by the n.m.r. signals at  $\tau$  6.70 and 6.65. The assignments of the bicyclic pyran to (11) and the bicyclic furan to (12) were derived from the close similarity of the chemical shifts for the bridgehead protons in both compounds ( $\tau$  6.10 and 5.56) with known systems.<sup>12</sup> The axial orientations of the C-2 and C-6 protons in compound (11) were indicated by the doublets of triplets at  $\tau$  6.49 ( $J = 11.0$  and  $5.5$  Hz) and at  $7.74$  ( $J = 11.0$  and  $4.5$  Hz). The n.m.r. spectrum of compound (12) was not well resolved, but the pseudo-axial orientations of the C-2 and C-5 protons were suggested by the half-height width of the multiplets at  $\tau$  6.58 and 7.50. The mass spectra of compounds (11) and (12) showed many major peaks in common; in addition the former showed a weak peak at  $m/e$  114 and the latter minor peaks at  $m/e$  140, 124, and 82. Although these extra peaks can be rationalized on the basis of the structures,<sup>7</sup> they could not

\* The decoupled spectra and computer simulated spectra are given in ref. 7.

be used as primary evidence because of lack of known models.

The oxidative photoaddition of *N*-nitrosopiperidine (NNP) or NND to cyclohexa-1,3-diene apparently resulted in the formation of allylic nitrates such as *cis*- and *trans*-1-nitro-oxy-4-piperidinocyclohex-2-ene (13) and the corresponding 1,2-adduct. In ether solution, the basic products decomposed gradually to darken the solution but on evaporation they decomposed explosively to give a black tar. Immediate reduction of the ether solution of the crude basic fraction with  $\text{LiAlH}_4$  followed by chromatography gave 3-piperidinocyclohexane (20%) as the major product. The C-3 methine proton at  $\tau$  6.9 and the other

two allylic protons at  $\tau$  8.00 were shown to be coupled with the vinyl protons. The minor product, 4-piperidinocyclohex-2-enol (15), was obviously a mixture of two stereoisomers as indicated by the spectral data, and could not be obtained in the pure state. The alcohols corresponding to 1,2-addition were probably also formed, as shown by the minor spots in the t.l.c. plate of the crude basic product.

#### DISCUSSION

In oxidative photoaddition of a nitrosamine to a simple olefin, a 1-ammonio-2-nitro-oxyalkane is the final product if this product does not undergo further reaction. While an isolated nitrate group is generally stable to various reaction conditions,<sup>13,14</sup> an allylic nitrate group such as that of compound (13) is obviously unstable and undergoes complex reactions which may lead to the low

- <sup>12</sup> S. Moon and L. Haynes, *J. Org. Chem.*, 1966, **31**, 3067.  
<sup>13</sup> P. A. S. Smith, 'Open Chain Nitrogen Compounds,' W. A. Benjamin, New York, 1966, vol. II.  
<sup>14</sup> J. W. Baker and D. M. Easty, *J. Chem. Soc.*, 1952, 1193, 1208; 1955, 616.

yields of compounds (14) and (15). A nitrate ion is a weak base and a very stable anion, but it is not known as a good leaving group. With a stereoelectronic assistance, however, heterolytic dissociation of a nitrate linkage,<sup>2</sup> such as in (13), may not be difficult.

In the two mechanisms for the formation of nitrates during the photoaddition of nitrosamines to olefins in the presence of oxygen,<sup>2</sup> the key step is either the attack of oxygen on nitric oxide to form  $\cdot\text{NO}_3$  as in path (a) or the attack of oxygen in the C-radical intermediate (16) followed by combination with nitric oxide to form a peroxyxynitrite (19) as in path (b). Whereas we have favoured path (a) on stereochemical grounds, path (b) cannot be excluded since a carbon radical combines with oxygen at a diffusion-controlled rate to form a peroxy-radical.<sup>15</sup> As will be seen later a peroxyxynitrite intermediate such as (19) may be required to explain the observed reaction pattern.

It has been well established that free-radical addition to norbornadiene and cyclo-octa-1,5-diene may proceed

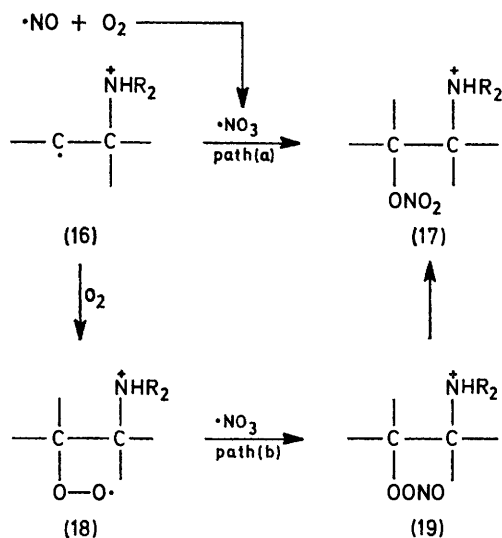

by either 1,2-addition or transannular addition *via* C-radicals (as depicted below), depending on the chain-transfer constant, *i.e.* rates of ring closures [*e.g.* (20)  $\rightarrow$  (21)], in competition with the rate of the radical transfers<sup>16-19</sup> [*e.g.* (20) or (22) reacting with a substrate]. This conclusion implies that the ring-closure processes are not reversible and that the relative kinetics of the C-radical intermediates decide the product ratios. Under the present conditions, the rate of reaction of a C-radical with oxygen (or  $\cdot\text{NO}_3$ ) is slower than the ring closure of (20)  $\rightarrow$  (21) but faster than that of (22)  $\rightarrow$  (23).

The stereochemical pattern of the addition of the

<sup>15</sup> J. A. Howard, in 'Free Radicals,' ed. J. K. Kochi, John Wiley and Sons, New York, 1973, vol. II, p. 3.

<sup>16</sup> J. W. Wilt, in 'Free Radicals,' ed. J. K. Kochi, John Wiley and Sons, New York, 1973, vol. I, p. 333.

<sup>17</sup> R. Dowbenko, *Tetrahedron Letters*, 1964, 1843.

<sup>18</sup> R. H. Fish, *J. Amer. Chem. Soc.*, 1967, **89**, 5861.

<sup>19</sup> D. I. Davies, in 'Essays in Free Radical Chemistry,' *Chem. Soc. Special Publ.*, No. 24, 1970, 201.

aminium radical and oxygen (or  $\cdot\text{NO}_3$ ) to bicyclo-[2.2.1]heptadiene is similar to those of other stepwise

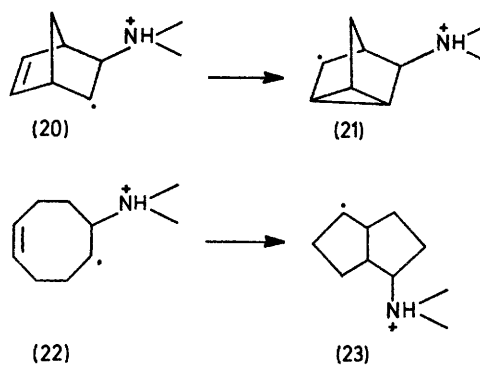

radical reactions.<sup>19</sup> The stereochemical course of the same addition to cyclo-octa-1,5-diene produces both the *cis*-1,2-adduct as well as the *trans*-1,2-adduct. It is envisaged that unstable adducts such as those corresponding to the peroxyxynitrite (19) have been formed as the primary products which undergo rearrangements to give (8) from the *trans*-1,2-adducts (8;  $\text{ONO}_2 = \text{OONO}$ ), and the oxabicyclic compounds (11) and (13) from the *cis*-1,2-adduct (9;  $\text{X} = \text{ONO}$ ). The latter rearrangement involves a transannular  $\pi$ -electron participation<sup>20,21</sup> no doubt, owing to the close proximity and a favourable orientation of the *p*-orbitals and the electron-deficient oxygen atom [see compound (24)]. Examination of molecular models suggests that the cyclo-octenyl peroxyxynitrite (9) could assume a twist-boat-chair conformation (24) to minimise non-bonded interaction as well as to fulfil the stereoelectronic requirements. It is convenient to use an oxonium ion intermediate<sup>22</sup> (25) to visualize the reaction leading to (11)

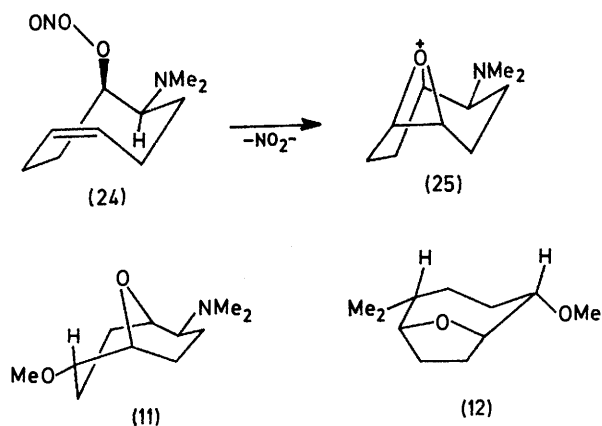

and (12), but its presence as a discrete intermediate is not proven. The approach of a nucleophilic methanol molecule from the opposite side to the oxonium ring leads to the stereochemistry observed in compounds (11)

<sup>20</sup> A. C. Cope, M. A. McKervey, and N. M. Weinshenker, *J. Amer. Chem. Soc.*, 1967, **89**, 2932.

<sup>21</sup> A. C. Cope, M. M. Martin, and M. A. McKervey, *Quart. Rev.*, 1966, **20**, 119.

<sup>22</sup> Cf. L. A. Paquette and P. C. Storm, *J. Amer. Chem. Soc.*, 1970, **92**, 4295.

and (12). Ionic dissociation of the *trans*-peroxynitrite (24; the OONO group in the pseudo-equatorial orientation) does not meet the necessary stereoelectronic requirements and, therefore, collapses to the nitrate ester (8), probably from its ion pair.

Heterolysis of the unisolated peroxynitrites must occur extremely rapidly since such a peroxynitrite species may readily undergo photoinitiated homolysis if its lifetime is long enough. Such homolysis would generate an alkoxy-radical which would undergo complex radical reactions. An alternative possibility that the *cis*-nitrate ester (9; X = NO<sub>2</sub>) rearranges to give compounds (11) and (12) appears to be less probable since dissociation of an O-N bond is an uncommon process. This suggests that path (a) of the nitrate-formation mechanism may be more probable.

#### EXPERIMENTAL

I.r. spectra were taken in liquid films or Nujol nulls, u.v. spectra in methanol solution, and n.m.r. spectra were recorded on a Varian A 56/60 or a Varian XL-100 spectrophotometer using deuteriochloroform as solvent and tetramethylsilane as internal standard. Chemical shifts are reported in  $\tau$  values, coupling constants ( $J$ ) and half-height widths ( $W_{1/2}$ ) in Hz. The decoupling experiments were performed by Mr. John Pastucha on the XL-100 spectrometer. Mass spectra and high-resolution mass spectra were obtained on a Hitachi-Perkin-Elmer model RMU-6E instrument with an ionization voltage of 80 eV; the intensity of the peaks is given as percentage of the base peaks. *N*-Nitrosodimethylamine (NND, Eastman 7370) and *N*-nitrosopiperidine (NNP, Eastman 2277) and the olefins (Aldrich Chemical Co.) were distilled before use.

*Oxidative Addition of NND to Bicyclo[2.2.1]hepta-2,5-diene.*—A solution of NND (3.552 g, 0.048 mol), bicyclo[2.2.1]hepta-2,5-diene (3.68 g, 0.04 mol), and perchloric acid (60%, 8 ml) in methanol (300 ml) was cooled to 0 °C and irradiated with a 200 W Hanovia lamp through a Nonex filter under oxygen until the absorption at 343 nm had completely disappeared. After irradiation (4 h), the photolysate was filtered to leave a white solid (1.19 g, 10%) which was recrystallized twice from ethanol-water to give the perchlorate of *exo*-5-dimethylamino-*endo*-3-nitro-oxytricyclo[2.2.1.0<sup>2,6</sup>]heptane (4a): m.p. 211–215 °C (decomp.); i.r. 3 140, 1 635, 1 305, 1 290, 1 100, 1 070, 1 060, 1 040, 870, 838, 828, 810, and 760 cm<sup>-1</sup>; n.m.r. [(CD<sub>3</sub>)<sub>2</sub>SO]  $\tau$  1.16 (m, D<sub>2</sub>O exch., NH), 4.80 (t,  $J$  = 1.5 Hz, 3-H), 6.35 (d,  $J$  = 9 Hz, 5-H), 7.04 (d,  $J$  = 4.5 Hz, N-CH<sub>3</sub>), 7.22 (d,  $J$  = 4.5 Hz, N-CH<sub>3</sub>), 7.31 (d,  $J$  = 1.5 Hz, 4-H), 7.94 (t,  $J$  = 5.2 Hz, 6-H), and 8.21 (m, 4 H). (Found: C, 36.2; H, 5.0; N, 9.35. Calc. for C<sub>9</sub>H<sub>15</sub>ClN<sub>2</sub>O<sub>7</sub>: C, 36.19; H, 5.06; N, 9.38%).

The filtrate was concentrated to a small volume, treated with water (50 ml) and extracted with ether (50 ml  $\times$  3) to give an oil (620 mg) which showed several spots on a t.l.c. plate and a complex n.m.r. spectrum containing no N-CH<sub>3</sub> absorptions. The aqueous acidic solution was basified with saturated sodium carbonate solution and extracted with methylene chloride (50 ml  $\times$  5) to give a reddish brown oil (3.3 g): i.r. 2 830, 2 780, 1 625, 1 295, 1 280, and 865 cm<sup>-1</sup>.

A portion of this oil (1 g) was chromatographed on neutral alumina (30 g) with chloroform as eluant to give two main fractions, the second of which (272 mg) was shown to contain mostly the nortricyclic *exo*-nitrate (3a) on the basis

of spectral and t.l.c. analysis. The first fraction (683 mg) was rechromatographed on neutral alumina (40 g), using benzene as eluant, to give an initial fraction (94 mg) which showed the characteristic nitrate absorptions at 1 620, 1 280, and 865 cm<sup>-1</sup> and contained *exo*-5-dimethylamino-*exo*-3-nitro-oxytricyclo[2.2.1.0<sup>2,6</sup>]heptane (3a) and *exo*-3-dimethylamino-*endo*-2-nitro-oxybicyclo[2.2.1]hept-5-ene (2a) as well as *exo*-3-dimethylamino-*exo*-2-nitro-oxybicyclo[2.2.1]hept-5-ene (1a) in the ratio of 3.1 : 1.9 : 2.7 by n.m.r. analysis:  $\tau$  3.68 (d of dd,  $J$  = 6.0, 3.5 and 1.0 Hz, 1 H), 4.08 (d of dd,  $J$  = 6.0, 3.0 and 0.5 Hz, 1 H), 4.37 (q,  $J$  = 3.0 Hz, 2 H), 5.18 (t,  $J$  = 1.5 Hz, 1 H), 7.75 (s, 6 H), 7.81 (s, 6 H), and 7.87 (s, 6 H).

The crude fraction (2.3 g) was reduced with LiAlH<sub>4</sub> (2.28 g) in tetrahydrofuran (200 ml) for 24 h to give a viscous oil (1.96 g). Chromatography on neutral alumina (60 g) with 10–50% chloroform in benzene as eluant gave a semisolid (615 mg) which was sublimed at 20 °C and 0.5 mmHg to give *exo*-5-dimethylamino-*exo*-tricyclo[2.2.1.0<sup>2,6</sup>]heptan-3-ol (3b) as fine needles: m.p. 82–84 °C; i.r. 3 140, 3 060, 3 005, 2 830, 2 785, 1 093, 1 040, 1 008, 820, and 805 cm<sup>-1</sup>; n.m.r.  $\tau$  8.65 (m, 3 H), 8.29 (A part of AB,  $J_{AB}$  = 11.0 Hz,  $\Delta\nu_{AB}$  = 9.5 Hz, each peak further split into a triplet,  $J$  = 1.0 Hz, *anti*-7-H), 8.20 (B part of AB, each peak further split into a triplet,  $J$  = 1.0 Hz, *syn*-7-H), 8.08 (m, 2 H), 8.04 (m, D<sub>2</sub>O exch., 1 H), 7.84 (s, 6 H), and 6.21 (t,  $J$  = 1.5 Hz, 3-H); m.s. (125 °C)  $m/e$  (%) 153.114 6 ( $M^+$ , 100; calc. for C<sub>9</sub>H<sub>15</sub>NO 153.115 4), 152 (26), 136.113 7 (60; calc. for C<sub>9</sub>H<sub>14</sub>N, 136.112 6), 108.056 1 (100; calc. for C<sub>7</sub>H<sub>8</sub>O, 108.057 5), 91.052 5 (81, calc. for C<sub>7</sub>H<sub>7</sub>, 91.054 8), 84 (79), 79 (73), 71 (55), 69 (63), and 58 (50). Irradiation of either multiplet at  $\tau$  8.65 (2-H) or at  $\tau$  8.08 (4-H) resulted in the collapse of the triplet at 6.21 (3-H) to a doublet ( $J$  = 1.5 Hz) (Found: C, 70.7; H, 10.15; N, 9.15. Calc. for C<sub>9</sub>H<sub>15</sub>NO: C, 70.55; H, 9.87; N, 9.14%).

Subsequent elution with chloroform and chloroform-methanol mixtures gave the alcohol (3) and a small amount (80 mg) of an unidentified compound; i.r. 3 360, 2 830, 2 790, and 1 025 cm<sup>-1</sup>; n.m.r.  $\tau$  5.88 (bs), 6.32 (dt,  $J$  = 6.5 and 2.5 Hz), 7.20–8.0 (m), and 8.0–8.97 (m).

*Reduction of the endo-Nitrate (4a).*—The perchlorate salt of (4a) was dissolved in cold water, neutralized with saturated sodium carbonate solution, and immediately extracted with ether to give the *endo*-nitrate (4a) as a colourless oil: i.r. 3 080, 2 830, 2 780, 1 625, 1 305, 1 280, 1 270, 985, 865, 830, and 815 cm<sup>-1</sup>; n.m.r. (CCl<sub>4</sub>)  $\tau$  5.10 (t,  $J$  = 1.5 Hz, 3-H), 7.45 (t,  $J$  = 1.5 Hz, 5-H), 7.80 (s, 6 H), 7.90 (m, 4-H), 8.10 (m, 6-H), and 8.48 (m, 4 H).

A solution of this oil (400 mg) in dry ether (50 ml) was added to a suspension of LiAlH<sub>4</sub> (304 mg, 0.008 mol) in dry ether (100 ml) at 0 °C. The reaction mixture was stirred for 24 h at room temperature, hydrolysed with a calculated amount of water, and filtered. The inorganic solid was washed thoroughly with ether, and the filtrate and the washings were combined and dried (MgSO<sub>4</sub>). After removal of the ether a low-melting solid (250 mg) remained which was purified by sublimation at 20 °C and 0.5 mmHg to give white crystals of (4b): m.p. 95–98 °C; i.r. 3 140, 3 070, 2 835, 2 790, 1 325, 1 310, 1 082, 825, 812, and 805 cm<sup>-1</sup>; n.m.r.  $\tau$  6.01 (t,  $J$  = 1.6 Hz, 3-H), 7.36br (s, 5-H), 7.75 (s, 6 H), 8.11 (m, 4-H), 8.20 (A part of AB,  $J_{AB}$  = 10.5 Hz, each line further split into a triplet,  $J$  = 1.0 Hz, *anti*-7-H), 8.63 (m, 3 H) and 8.71 (B part of AB, each line further split into a triplet,  $J$  = 1.0 Hz, *syn*-7-H); mass spec. (50 °C)  $m/e$  (%) 153.112 8 ( $M^+$ , 100; Calc. for C<sub>9</sub>H<sub>15</sub>NO,

153.115 4), 152 (31), 138 (46), 136.110 9 (100; Calc. for  $C_9H_{14}N$ , 136.112 6), 110 (31), 109 (31), 108.056 5 (52; Calc. for  $C_9H_8O$ , 108.057 5), 107 (25), 94 (46), 91.052 7 (88; Calc. for  $C_7H_7$ , 91.054 8), 84 (55), 79 (86), 77 (47), 71 (39), 69 (100), and 58 (43). On irradiation of the multiplet at  $\tau$  8.63 (2-H), the triplet at  $\tau$  6.01 (3-H) collapsed to a doublet ( $J = 1.6$  Hz) (Found: C, 70.75; H, 9.95; N, 9.05. Calc. for  $C_9H_{14}NO$ : C, 70.55; H, 9.87; N, 9.14%).

*Oxidation of the exo-Alcohol (3b) and the endo-Alcohol (4b).*—A solution of the *endo*-alcohol (4b) (100 mg,  $6.5 \times 10^{-4}$  mol) in acetone (2 ml) was stirred with a Jones reagent ( $7 \times 10^{-4}$  mol) at room temperature for 3 h. Water (2 ml) was added to the mixture, and the acetone was evaporated off. The resulting mixture was basified with sodium carbonate solution and extracted with methylene chloride to give an oil (85 mg) which was distilled at 20 °C and 0.5 mmHg to give *exo*-5-dimethylaminotricyclo[2.2.1.0<sup>2,6</sup>]-heptan-3-one (5) as a colourless oil: i.r. 3 070, 3 030, 2 830, 2 783, 1 760, 1 055, 1 045, 863, 855, 838, and 805  $cm^{-1}$ ; n.m.r.  $\tau$  7.50 (t,  $J = 1.0$  Hz, 5-H), 7.69 (m, *syn*-7-H), 7.75 (s, 6 H), 7.83 (m, 2 H), 7.99 (m, 1-H), 8.12 (d,  $J = 10.5$  Hz, each line further split into a triplet,  $J = 1.5$  Hz, *anti*-7-H) and 8.50 (t,  $J = 5.5$  Hz, each line further split into a doublet,  $J = 1.0$  Hz, 6-H); mass spec. (120 °C)  $m/e$  (%) 151.101 0<sub>9</sub> ( $M^+$ , 100; Calc. for  $C_9H_{13}NO$ , 151.099 7), 123 (34), 122 (57), 108 (36), 107 (33), 94 (27), 82 (39), 79 (82), 77 (50), and 69 (48).

Oxidation of the *exo*-alcohol (3b) (80 mg) with Jones reagent in acetone as described above and distillation of the crude product (40 mg) at 20 °C and 0.5 mmHg afforded the same tricyclic ketone (5).

*Oxidative Addition of NND to Cyclo-octa-1,5-diene.*—A solution of NND (3.5 g, 0.048 mol), cyclo-octa-1,5-diene (Aldrich, b.p. 48–49 °C/28 mmHg, 4.3 g, 0.04 mol) and perchloric acid (70%, 7 ml) in methanol (320 ml) was cooled to 0 °C and irradiated with a 200-W Hanovia lamp through a Nonex filter under oxygen for 3 h at which time the absorption at 343 nm had completely disappeared. The colourless photolysate was concentrated to ca. 50 ml under reduced pressure at 10 °C, diluted with water (ca. 50 ml), and extracted with ether ( $5 \times 50$  ml). The pale yellow oil (223 mg) obtained from the ether extracts showed no N-CH<sub>3</sub> signal in its n.m.r. spectrum and was discarded.

The aqueous acidic solution was cooled to 0 °C, basified (pH 9.5) with saturated sodium carbonate solution, and immediately extracted with methylene chloride ( $5 \times 75$  ml). The extract was washed with water ( $3 \times 50$  ml) and dried (MgSO<sub>4</sub>). The solvent was removed under reduced pressure at 10 °C to give a yellowish viscous oil (7.21 g); i.r. 3 400, 1 615, 1 275, 1 100, 1 030, 860, 735, and 720  $cm^{-1}$ ; n.m.r.  $\tau$  4.37 (m), 4.8 (m), 6.65 (s), 7.70 (s), and 7.77 (s). The intensities of the n.m.r. signals at  $\tau$  4.37 and 6.65 indicated the presence of an olefinic and a methoxy-compound in the approximate ratio 2.5 : 1 and the t.l.c. showed two strong and three weak spots.

To the tetrahydrofuran (50 ml) solution of the crude basic fraction was added with stirring at 0 °C LiAlH<sub>4</sub> (6.08 g, 0.16 mol) in tetrahydrofuran (50 ml); the mixture was allowed to warm to room temperature and stirred for another 24 h. After hydrolysis, filtration, and thorough washing of the inorganic solid residue with tetrahydrofuran, the filtrate and washings were combined and dried (MgSO<sub>4</sub>). Removal of the solvent gave an oil (6.6 g) which showed one major and two minor spots in a t.l.c. plate: i.r. 3 400, 3 010, 1 045, and 1 030  $cm^{-1}$ ; n.m.r. (CCl<sub>4</sub>)  $\tau$  4.48 (m),

6.72 (s), 7.73 (s), 7.8 (s), and 7.83 (s). The ratio of the three N-CH<sub>3</sub> signals in the n.m.r. spectrum was estimated to be 6 : 3 : 1.

This mixture (6.2 g) was chromatographed on basic alumina (100 g). The first fraction (A) (4.3 g) eluted with methylene chloride showed two predominant spots on a t.l.c. plate. Continued elution with 0–1% methanol in methylene chloride gave an oil (1.75 g) which contained predominantly the amino-alcohol (10) (identified by i.r. and n.m.r. spectroscopy).

Fraction (A) (2.3 g) was rechromatographed on basic alumina (230 g) using 2% methanol in methylene chloride as the eluant to give a colourless oil which showed one spot on a t.l.c. plate. This oil was distilled at 20 °C and 0.5 mmHg to afford *exo*-6-dimethylamino-*endo*-2-methoxy-9-oxabicyclo[3.3.1]nonane (11): i.r. 2 820, 2 770, 1 130, 1 120, 1 100, 1 085, 1 055, 890, and 880  $cm^{-1}$ ; n.m.r.  $\tau$  6.10 (m, 1-H and 5-H), 6.49 (dt,  $J = 11.0$  and 5.5 Hz, 2-H), 6.66 (s, 3 H), 7.74 (dt,  $J = 11.0$  and 4.5 Hz, 6-H), 7.77 (s, 6 H) and 8.13 (m, 8 H); mass spec. (20 °C)  $m/e$  (%) 199.156 9 ( $M^+$ , 27; calc. for  $C_{11}H_{21}NO_2$ , 199.157 2), 168.137 2 (11; calc. for  $C_{10}H_{18}NO$ , 168.138 8), 114 (1), 84 (77), 71 (100), and 56 (16). On irradiation of the multiplet at  $\tau$  8.13, the signal at 6.49 (2-H) collapsed to a doublet ( $J = 5.5$  Hz) and the multiplet at 6.10 (1-H and 5-H) collapsed to two doublets ( $J = 5.5$  and 4.5 Hz). (Found: C, 66.1; H, 10.8; N, 7.25. Calc. for  $C_{11}H_{21}NO_2$ : C, 66.29; H, 10.62; N, 7.03%).

Continued elution with 2% methanol in methylene chloride gave an oil (405 mg) which contained compounds (11) and (12) in the ratio 1 : 2.7 as estimated from the relative intensity of the N-CH<sub>3</sub> singlets at  $\tau$  7.75 and 7.72 and that of the OCH<sub>3</sub> singlets at  $\tau$  6.7 and 6.65. A portion of this oil (300 mg) was rechromatographed on basic alumina (50 g). The first fraction, eluted with 1% methanol in methylene chloride was an oil (242 mg) containing compounds (11) and (12) in an approximate ratio 1 : 2. The colourless oil (46 mg) obtained from the next fraction was distilled at 20 °C and 0.5 mmHg to give *exo*-5-dimethylamino-*endo*-2-methoxy-9-oxabicyclo[4.2.1]nonane (12); i.r. 2 820, 2 770, and 1 100  $cm^{-1}$ ; n.m.r.  $\tau$  5.56 (m,  $W_{1/2} = 32$  Hz, 1-H and 6-H), 6.58 (m, 2-H), 6.65 (s, 3 H), 7.5 (m, 5-H), 7.71 (s, 6 H), and 8.2 (m, 8 H); mass spec. (20 °C)  $m/e$  (%) 199 ( $M^+$ , 34), 168 (63), 154 (19), 140 (8), 124 (18), 85 (3), 84 (100), 82 (19), 71 (83), 70 (27), 58 (26), and 56 (20) (Found: C, 66.55; H, 10.8; N, 7.15. Calc. for  $C_{11}H_{21}NO_2$ : C, 66.29; H, 10.62; N, 7.03%).

Subsequent elution with 2% methanol in methylene chloride gave a mixture (150 mg) containing compounds (12) and the amino-alcohol (10) in the approximate ratio 1 : 1. The succeeding several fractions gave an oil (647 mg) which was sublimed at 20 °C and 0.05 mmHg to give *trans*-2-dimethylaminocyclo-oct-5-en-1-ol (10): i.r. 3 360, 3 010, 2 830, 2 790, 1 045, 1 030, 730, and 715  $cm^{-1}$ ; n.m.r.  $\tau$  4.35 (A part of ABX<sub>2</sub>X'<sub>2</sub>,  $J_{AB} = 11.5$  Hz,  $J_{AX} = 5.0$  Hz,  $\Delta\nu_{AB} = 21.0$  Hz, 6-H), 4.56 (B part of ABX<sub>2</sub>X'<sub>2</sub>,  $J_{BX} = 7.0$  Hz, 5-H), 5.06br (s, D<sub>2</sub>O exch., 1 H), 6.49 (d of dd,  $J = 9.0, 7.0$ , and 3.0 Hz, 1-H), 7.39 (d of dd,  $J = 10.5, 9.0$ , and 4.0 Hz, 2-H), 7.72 (s, 6 H), 7.52–7.99 (m, 4 H) and 8.38 (m, 4 H); mass spec. (20 °C)  $m/e$  (%) 169.146 1 ( $M^+$ , 17; Calc. for  $C_{10}H_{18}NO$ , 169.146 7), 140 (13), 110 (14), 84 (13), 72 (27), 71 (100), 56 (21), and 42 (17). On irradiation of the multiplet at  $\tau$  7.52–7.99 (allylic protons), the signal at  $\tau$  4.45 (vinyl protons) collapsed to an AB quartet with a  $J_{AB}$  value of 11.5 Hz. When the multiplet at  $\tau$  8.38 was

irradiated, the signals at  $\tau$  6.49 (1-H) and 7.39 (2-H) collapsed to doublets ( $J = 9.0$  Hz). On irradiation of the signal at  $\tau$  7.39 (2-H), the signal at  $\tau$  6.49 (1-H) collapsed to a double doublet ( $J = 7.0$  and  $3.0$  Hz) and the multiplet at  $\tau$  8.38 showed some changes in its coupling pattern. Irradiation at  $\tau$  4.45 (vinyl protons) and at  $\tau$  6.49 (1-H) changed the coupling pattern of the multiplets at  $\tau$  7.52—7.99 (allylic protons) and at  $\tau$  8.38, respectively. (Found: C, 70.85; H, 11.55; N, 8.5. Calc. for  $C_{10}H_{19}NO$ : C, 70.96; H, 11.31; N, 8.27%).

The material remaining on the column (760 mg) was eluted with 5—10% methanol in methylene chloride and consisted mainly of the amino-alcohol (10).

*Oxidative Addition of NNP to Cyclohexa-1,3-diene.*—A solution of NNP (5.472 g, 0.048 mol), cyclohexa-1,3-diene (3.20 g, 0.04 mol), and concentrated hydrochloric acid (4.8 ml) in methanol (320 ml) was photolysed as described above. The yellow photolysate was concentrated to ca. 50 ml under reduced pressure at  $10^\circ\text{C}$  during which the solution darkened rapidly. The solution was diluted with water to ca. 100 ml and extracted with ether to give a yellow semisolid (1.55 g) which exhibited i.r. absorptions at 3 440, 1 720, 1 690, 1 630, 1 550, 1 275, 1 050, and 860  $\text{cm}^{-1}$ . The aqueous acidic solution was cooled below  $0^\circ\text{C}$ , basified (pH 8) with saturated sodium carbonate solution and extracted immediately with cold ether. The ethereal extract was washed with cold water, dried ( $\text{MgSO}_4$ ), added to a suspension of  $\text{LiAlH}_4$  (6.08 g, 0.16 mol) in anhydrous ether (250 ml) at  $0^\circ\text{C}$  and stirred at room temperature for 24 h. The resultant mixture was worked up to give a basic fraction (2.3 g) which exhibited one major and three minor components on t.l.c.

A portion of this mixture (1.75 g) was chromatographed on basic alumina (60 g). Elution with methylene chloride afforded a colourless oil (411 mg) which showed a single spot on a t.l.c. plate and gave, on distillation at  $20^\circ\text{C}/0.5$  mmHg, 3-piperidinocyclohexene (14): i.r. 3 020, 2 800, 2 750, 2 680, 1 325, 1 305, 1 160, 1 120, and 725  $\text{cm}^{-1}$ ; n.m.r. ( $\text{CCl}_4$ )  $\tau$  4.41 (m, 2 H), 6.9 (m,  $W_{1/2} = 12$  Hz, 3-H), 7.52 (m,  $W_{1/2} = 12$  Hz, 4 H), 8.0 (m, 2 H), and 8.54 (m, 10 H); mass spec. ( $20^\circ\text{C}$ )  $m/e$  (%) 165.150 0 ( $M^+$ , 32; Calc. for  $C_{11}H_{19}N$ , 165.151 7), 137.121 7 (72; Calc. for  $C_9H_{15}N$ , 137.120 4), 122 (51), 111.108 1 (100; Calc. for  $C_7H_{13}N$ , 111.104 8), 110 (31), 96 (41), 84 (23), 81 (25), 55 (25), 42 (20), and 41 (38). Irradiation of either the multiplets at  $\tau$  6.9 or those at 8.0 changed the coupling pattern of the multiplet at  $\tau$  4.41 (vinyl protons). (Found: C, 79.85, H, 11.75; N, 8.55. Calc. for  $C_{11}H_{19}N$ : C, 79.94; H, 11.59; N, 8.47%).

The fraction (454 mg) eluted with 1% methanol in methylene chloride was a mixture of the amino-alcohols (15) contaminated with compound (14) as shown by the t.l.c., i.r., and n.m.r. analyses.

Subsequent elution with 1—5% methanol in methylene chloride gave a viscous oil (551 mg) which consisted of several components (by t.l.c.) and, on distillation at  $20^\circ\text{C}$  and 0.5 mmHg, gave an oil containing predominantly 4-piperidinocyclohex-2-enols: i.r. 3 350, 3 025, 2 810, 1 155, 1 100, 1 060, 1 035, 955, and 740  $\text{cm}^{-1}$ ; n.m.r.  $\tau$  4.3 (m, 2 H), 5.82 (m,  $W_{1/2} = 25$  Hz, 1 H), 6.86 (m,  $W_{1/2} = 23$  Hz, 1 H), 7.52 (m) and 8.5 (m); mass spec. ( $50^\circ\text{C}$ )  $m/e$  (%) 181 ( $M^+$ , 27), 153 (94), 137 (87), 124 (100), 111 (51), 98 (70), 84 (76), and 55 (39).

[6/360 Received, 20th February, 1976]