

Radical-cations as Reference Chromogens in Kinetic Studies of One-electron Transfer Reactions: Pulse Radiolysis Studies of 2,2'-Azinobis-(3-ethylbenzthiazoline-6-sulphonate)

By Brian S. Wolfenden and Robin L. Willson,* Biochemistry Department, Brunel University, Uxbridge, Middlesex UB8 3PH

Electrophilic free radicals such as OH^\bullet , RS^\bullet , $\text{CCl}_3\text{O}_2^\bullet$, $\text{Br}_2^{\bullet-}$, and $(\text{SCN})_2^{\bullet-}$ react rapidly with 2,2'-azinobis-(3-ethylbenzthiazoline-6-sulphonate) (ABTS) to form the radical-cation $\text{ABTS}^{\bullet+}$, λ_{max} 415 nm (ϵ $3.6 \times 10^4 \text{ l mol}^{-1} \text{ cm}^{-1}$). Absolute rate constants for these electron-transfer reactions have been determined by pulse radiolysis. Results suggest that $\text{ABTS}^{\bullet+}$ is likely to prove a useful reference free radical, not only for the study of reactions in which a free radical is the electron acceptor, but also in studies of reactions of organic radicals with sulphhydryl compounds.

LONG lived free radicals with high extinction coefficients such as those derived from quinones (Q) or viologens (V^{2+}) are proving particularly useful as reference solutes in pulse radiolysis studies of one-electron transfer reactions. A wide variety of redox couples in which the radical serves as the one-electron donor have been investigated and the one-electron oxidation-reduction potentials E_7^1 determined using the semiquinone equilibrium method.¹⁻³ For example from studies of equilibria of types (1) and (2) values $E_7^1(\text{O}_2-\text{O}_2^{\bullet-}) = -0.33 \text{ V}$ and $E_7^1(\text{NAD}^+-\text{NAD}^\bullet) = -0.93 \text{ V}$ have been derived.⁴⁻¹⁰

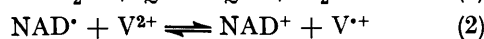
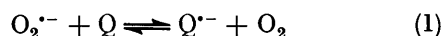

Our attention has now turned to the study of couples in which the free radical is the one-electron acceptor rather than the donor and a search for useful reference free radicals is currently in progress. The phenothiazines promethazine, chlorpromazine, and metiazinic acid and the aromatic amine tetramethylphenylenediamine are already under investigation.¹¹⁻¹⁸ Recently it was learnt that when the diammonium salt of 2,2'-azinobis-(3-ethylbenzthiazoline-6-sulphonic acid) ABTS (I) is incu-

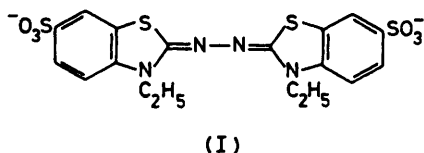

bated with peroxidase and hydrogen peroxide in aqueous solution the related long lived radical-cation ($\text{ABTS}^{\bullet+}$) with a high extinction coefficient at 414 nm is formed.¹⁹ It was considered of interest to investigate the reaction of the hydroxyl radical (OH^\bullet) and related electrophilic free radicals with ABTS by pulse radiolysis in the hope that the radical-cation might prove to be a useful reference chromogen in free radical oxidation-reduction studies.

EXPERIMENTAL

The 4 MeV linear accelerator and associated equipment for kinetic spectroscopy and computer analysis of data have already been described.^{20, 21} In the present study a 0.2 μs pulse producing a radiation dose of the order of 2–10 J kg^{-1} and an irradiation cell of 1.5 cm optical path length were used.

The diammonium salt of ABTS (molecular weight 548.7) was purchased from Boehringer Ltd., in the form of a green-blue powder. Aqueous solutions in the concentration range 10–50 μM had an absorption maximum at 340 nm (Figure 1). The maximum extinctions varied linearly with ABTS concentration and corresponded to a molar extinction coefficient ϵ_{340} of $3.66 \times 10^4 \text{ l mol}^{-1} \text{ cm}^{-1}$ in good agreement with the published value of $3.6 \times 10^4 \text{ l mol}^{-1} \text{ cm}^{-1}$.¹⁹ At ABTS concentrations greater than 1 mM, solutions appeared green-blue but became colourless when reducing agents such as ascorbate or cysteamine were added in relatively low concentrations. A difference spectrum (Figure 1) of a

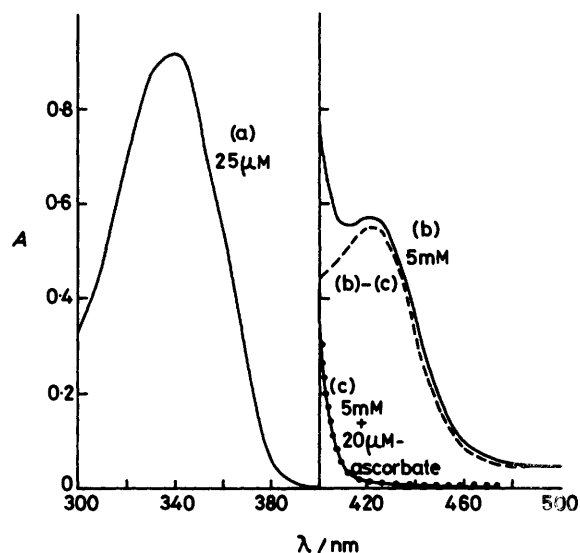

FIGURE 1 Optical absorption spectra of (a) 25 μM -ABTS, (b) 5 mM-ABTS, (c) 5 mM-ABTS + 20 μM -ascorbate, (d) difference spectrum (b) - (c)

solution of ABTS (5 mM) in the absence and presence of ascorbate (20 μM) showed a maximum at 415 nm indicative of trace amounts of the radical-cation being present. Taking the published extinction coefficient for $\text{ABTS}^{\bullet+}$, ϵ_{414} $3.6 \times 10^4 \text{ l mol}^{-1} \text{ cm}^{-1}$, the difference spectrum corresponded to the presence of $<0.3 \mu\text{M}$ radical cation in a 100 μM solution of the supplied powder. Further purification was considered unnecessary for these initial studies however, in view of the relatively high concentrations of other free-radical scavengers present in the systems to be investigated and the likely high reactivity of ABTS itself towards the electrophilic radicals of interest.

All solutions were freshly prepared in doubly distilled or

Millipore filtered water and exposed to the minimum of light. *t*-Butyl alcohol was purified by fractional crystallisation. Solutions were saturated with oxygen-free nitrogen and nitrous oxide (British Oxygen Ltd.) using the syringe-bubbling technique.²²

RESULTS

The transient absorption changes occurring on pulse radiolysis of aqueous solutions can generally be attributed to the reactions of hydrogen atoms, H^\bullet , solvated electrons, $e^-_{aq.}$, and hydroxyl radicals, OH^\bullet , formed on the radiolysis of water in respective yields of 0.06, 0.26, and $0.29\mu M J^{-1}$ of energy absorbed. The reaction of ABTS with OH^\bullet and a variety of other electrophilic free radicals have been followed using solutions containing selective free-radical scavengers whose reactions with the primary water radicals have been well characterised.^{12, 20}

(a) *Hydroxyl Radicals*.—Solvated electrons react rapidly with nitrous oxide (saturation concentration *ca.* 20mM in water at normal room temperature and pressure) to yield additional hydroxyl radicals [reaction (3)]. On pulse

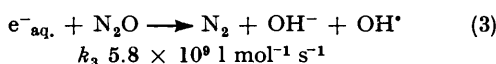

radiolysis of aqueous solutions of ABTS ($2 \times 10^{-5}M$; pH 6) a strong visible absorption (λ_{max} 415 nm) similar to that previously attributed¹⁹ to the radical-cation $ABTS^{+\bullet}$ was observed, together with a concomitant decrease in absorption between 300 and 350 nm where ABTS itself absorbs (Figure 2). Studies with concentrations of ABTS in

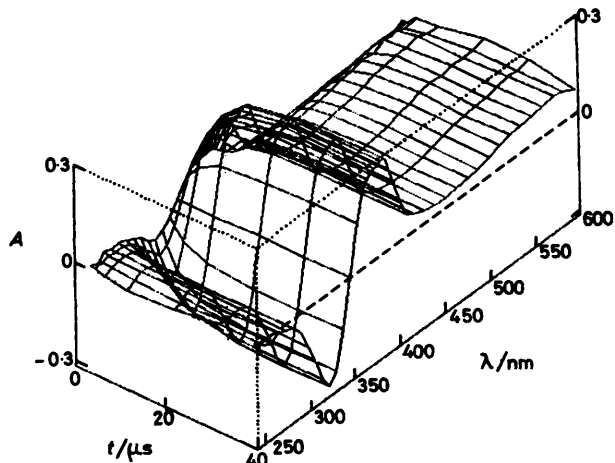
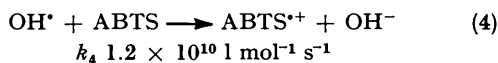

FIGURE 2 Transient absorption spectrum observed after various times on pulse radiolysis of an N_2O -saturated solution of ABTS ($20\mu M$; pH 6). Dashed line represents zero change in transmission

the range $20\text{--}80\mu M$ showed that the formation at 415 nm occurred exponentially and was first-order in ABTS concentration (Figure 3) in agreement with reaction (4).



To confirm that the observed changes were indeed due to (4) the effect of the presence of other solutes known to react with OH^\bullet but to form products not absorbing significantly at 415 nm was investigated. On pulse radiolysis of ABTS ($10^{-4}M$) in the presence of any one of the solutes (S) shown

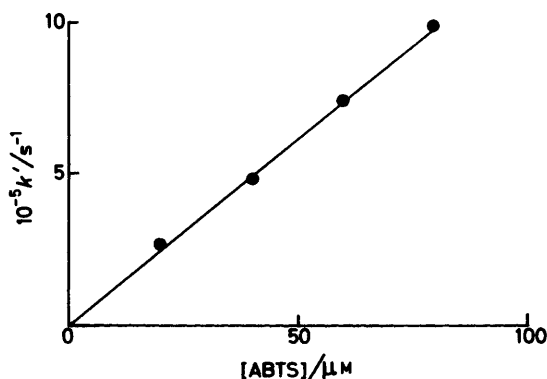
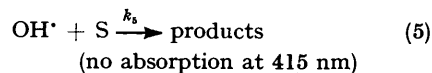

FIGURE 3 Plot of first-order rate constant against ABTS concentration for formation of the absorption at 415 nm on pulse radiolysis of N_2O -saturated solutions of ABTS

(Table 1), the 415 nm absorption decreased with increasing concentrations of S, in agreement with the competing reaction (5) and equation (6) where A° and A are the measured



$$A^\circ/A = 1 + k_5[S]/k_4[ABTS] \quad (6)$$

extinctions at 415 nm in the absence and presence of S, respectively. From the slopes of the competition plots

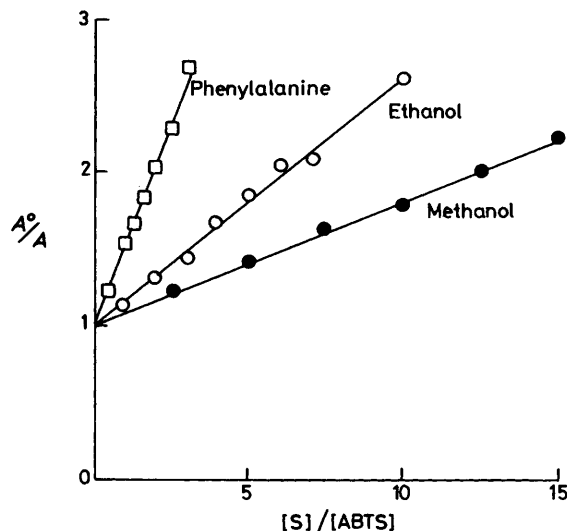

FIGURE 4 Competition plots showing the effect of different concentrations of hydroxyl-radical scavengers on the absorption at 415 nm produced on pulse radiolysis of N_2O -saturated solutions of ABTS ($100\mu M$)

(*e.g.* Figure 4) values of k_5/k_4 were derived. Values for k_5 subsequently calculated, taking $k_4 \ 1.2 \times 10^{10} \text{ l mol}^{-1} \text{ s}^{-1}$ as determined directly, are listed (Table 1).

(b) *Radical Anions* $Br_2^{\bullet-}$ and $(SCN)_2^{\bullet-}$.—On pulse radiolysis of nitrous oxide-saturated solutions containing either KBr or KSCN (0.1M) the characteristic strong transient absorption (λ_{max} 360 and 480 nm, respectively) of the related radical-anions $Br_2^{\bullet-}$ and $(SCN)_2^{\bullet-}$ were observed. In the presence of ABTS ($20\text{--}80\mu M$) the absorptions decayed exponentially. At 415 nm concomitant increases in absorption were observed with first-order formation constants increasing with increasing ABTS concentration

TABLE 1

Rate constant data obtained from competition studies using ABTS (see text)

S	$\frac{k_{OH^{\cdot}+S}}{k_{OH^{\cdot}+ABTS}}$	$10^{-9}k_{OH^{\cdot}+S}^a / 1 \text{ mol}^{-1} \text{ s}^{-1}$	10^{-9} Literature value ²³ / $1 \text{ mol}^{-1} \text{ s}^{-1}$
Formate	0.29	3.5 ± 0.2	3.5 ± 0.5
Methanol	0.083	0.99 ± 0.05	0.90 ± 0.1
Ethanol	0.16	1.90 ± 0.1	1.85
Isopropyl alcohol	0.16	1.9 ± 0.1	2.15 ± 0.15
t-Butyl alcohol	0.05	0.60 ± 0.04	0.52 ± 0.1
Acetone	0.011	0.13 ± 0.01	0.1 ± 0.03
Benzoate	0.52	6.3 ± 0.3	5.6 ± 0.2
Thymine	0.46	5.5 ± 0.3	5.4 ± 0.8

^a Taking $k_{OH^{\cdot}+ABTS} 1.2 \times 10^{10} \text{ l mol}^{-1} \text{ s}^{-1}$.

(Figure 5) in agreement with the predominant reactions being respectively (7) and (8).



$$k_7 1.1 \times 10^9 \text{ l mol}^{-1} \text{ s}^{-1}$$



$$k_8 1.5 \times 10^9 \text{ l mol}^{-1} \text{ s}^{-1}$$

(c) $\text{CCl}_3\text{O}_2^{\cdot}$ and Related Peroxyl Radicals.—On pulse radiolysis of air- but not nitrogen-saturated aqueous t-butyl alcohol (4 : 1; pH 6.6) solutions containing ABTS

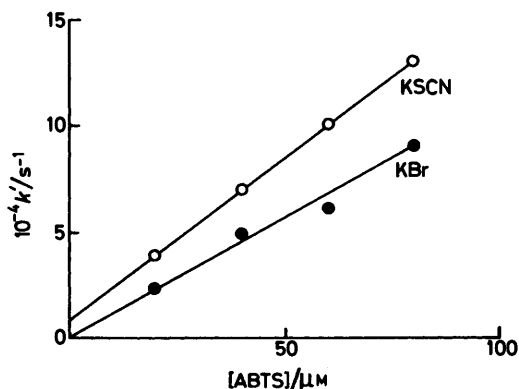
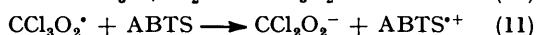
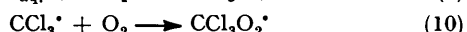
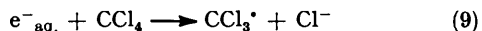

FIGURE 5 Plots of first-order rate constant against ABTS concentration for formation of the absorption at 415 nm on pulse radiolysis of N_2O -saturated solutions of ABTS containing excess of KBr or SCN (0.1M)

(20–80 μM) and carbon tetrachloride (10^{-2}M) the $\text{ABTS}^{\cdot+}$ absorption was again observed. The absorption was not apparent in aqueous t-butyl alcohol solutions in the absence of carbon tetrachloride. The rate of formation was again exponential with first-order rate constants increasing with increasing ABTS concentration (Figure 6) in agreement with reactions (9)–(11).^{24–29} Similar changes were observed with



$$k_{11} 1.9 \times 10^9 \text{ l mol}^{-1} \text{ s}^{-1}$$

aqueous t-butyl alcohol (9 : 1; pH 6.5) solutions containing chloroform and dichloromethane ($2 \times 10^{-2}\text{M}$) instead of carbon tetrachloride, in agreement with the occurrence of reactions (12) and (13) of the related peroxy radicals. On

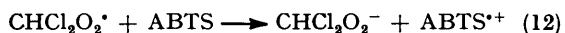

$$k_{12} 6.5 \times 10^8 \text{ l mol}^{-1} \text{ s}^{-1}$$

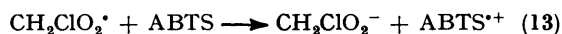

$$k_{13} 4.4 \times 10^7 \text{ l mol}^{-1} \text{ s}^{-1}$$

pulse radiolysis of $\text{N}_2\text{O}-\text{O}_2$ (4 : 1)-saturated aqueous dimethyl sulphoxide (9 : 1) solutions containing ABTS (2mM) no significant changes in absorption attributable to the

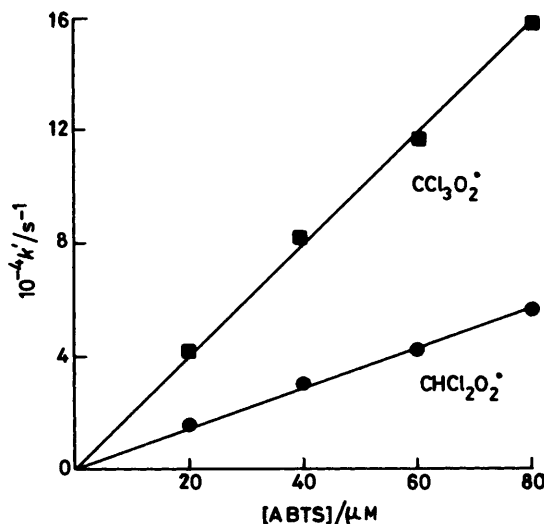
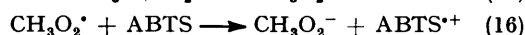
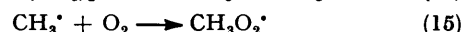
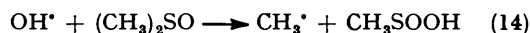

FIGURE 6 Plots of first-order rate constant against ABTS concentration for formation of absorption at 415 nm on pulse radiolysis of air-saturated aqueous t-butyl alcohol solutions containing CCl_4 and chloroform

formation of $\text{ABTS}^{\cdot+}$ were observed in agreement with reactions (14)–(16).^{28, 30, 31}



$$k_{16} < 10^5 \text{ l mol}^{-1} \text{ s}^{-1}$$

(d) Thiyl Radicals RS^{\cdot} .—During an attempt to determine the rate of reaction of OH^{\cdot} with the thiol cysteine, using ABTS as a reference solute, no significant reduction in the magnitude of the $\text{ABTS}^{\cdot+}$ absorption was apparent even at high cysteine concentrations. The formation of the absorption did however contain two components, a rapid component now attributed to reaction (4) and a slower component the proportion and rate of formation of which increased with increasing thiol (RSH) concentration in agreement with the occurrence of reactions (17) and (18). Similar absorption

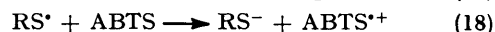
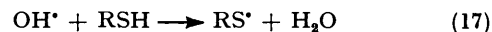

changes were observed when glutathione or cysteamine were substituted for cysteine and are attributed to the related reactions (18). Values for the respective rate constants given (Table 2) were determined using solutions (pH 6.8) containing excess of thiol ($2 \times 10^{-3}\text{M}$) and of ABTS (50–150 μM). The kinetic plots for cysteamine and cysteine are shown (Figure 7).

In the case of cysteamine additional support for the formation of $\text{ABTS}^{\cdot+}$ being due to reaction (16) was provided by related experiments with the oxidised analogue, cystamine (RSSR). On pulse radiolysis of nitrogen-saturated solutions containing cystamine (10^{-3}M) and t-butyl alcohol (1M) the $\text{ABTS}^{\cdot+}$ absorption was again observed but reduced

TABLE 2
Absolute rate constants and yields for formations of ABTS⁺ on reaction of ABTS with various radicals

Radical	Scavenger	$10^{-9}k/l \text{ mol}^{-1} \text{ s}^{-1}$	pH	G^* (ABTS)	
				theor.	exp.
OH [•]	N ₂ O	12	6.5	0.55	0.32
Br ₂ ^{•-}	N ₂ O-Br ⁻	1.1	6.6	0.55	0.46
(SCN) ₂ ^{•-}	N ₂ O-SCN ⁻	1.5	6.6	0.55	0.46
CCl ₃ O ₂ [•]	Bu ^t ; -CCl ₄ -air	1.9	6.6	0.26	0.22
CHCl ₂ O ₂ [•]	Bu ^t ; -CHCl ₃ -air	0.66	6.4	0.26	0.26
CH ₂ ClO ₂ [•]	Bu ^t ; -CH ₂ Cl ₂ -air	0.044	6.6	0.26	0.16
Cysteine S [•]	N ₂ O-cysteine	0.50	7.1	0.61	0.40
Glutathione S [•]	N ₂ O-glutathione	0.33	6.9	0.61	0.42
Cysteamine S [•]	N ₂ O-cysteamine	2.4	6.7	0.61	0.42
	ip/ac ^a -cysteamine	1.05			
	Bu ^t ; cystamine	1.2			
e ⁻ _{aq.}	Bu ^t	5.1	7.0		
	Bu ^t -Thymine	6.2			
X (see text)	Bu ^t	0.50	7.0	0.26	0.15

^a Isopropyl alcohol-acetone.

in magnitude by approximately one half. The rate of formation was first-order in ABTS concentration, in agreement with the reaction (18) being rate determining and thiyl

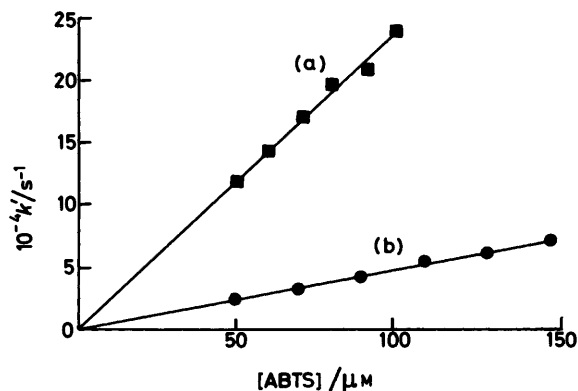
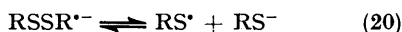
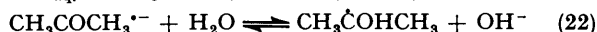
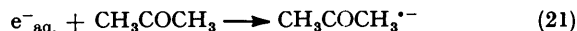

FIGURE 7 Plots of first-order rate constant against ABTS concentration for formation of absorption at 415 nm on pulse radiolysis of nitrous oxide-saturated solutions containing ABTS and (a) cysteamine or (b) cysteine ($2 \times 10^{-3} \text{M}$)

radicals being formed according to reactions (19) and (20).³²



On pulse radiolysis of nitrogen-saturated solutions (pH 7) containing isopropyl alcohol, acetone (1M), cysteamine ($2 \times 10^{-3} \text{M}$), and ABTS (50–100 μM) the ABTS⁺ absorption was again observed to be formed exponentially and first-order in ABTS concentration corresponding to reaction (18) again being rate determining and the formation of RS[•] according to reactions (21)–(24).³³



(e) 'Repair' of Organic Free Radicals by Hydrogen Atom Transfer from Thiols.—The observation that ABTS is readily oxidised by thiyl radicals raised the possibility that the radical-cation may be a useful chromogen for monitoring free-radical repair reactions involving hydrogen-atom transfer from thiol compounds to organic radicals.^{33, 34}

On pulse radiolysis of nitrogen-saturated solutions (pH

4.2) containing acetone (1M), isopropyl alcohol (1M), ABTS ($5 \times 10^{-3} \text{M}$), and cysteamine (40–300 μM) the ABTS⁺ absorption was again observed to be formed exponentially but now first-order in cysteamine concentration (Figure 8)

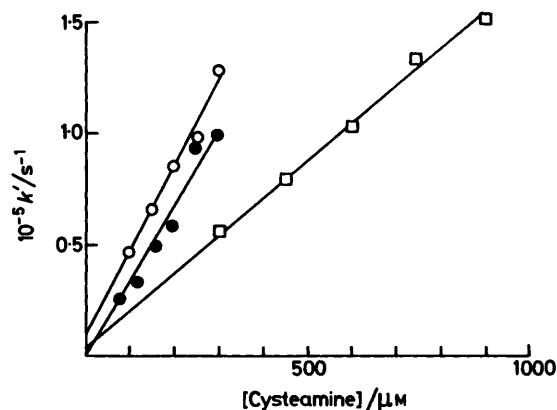

FIGURE 8 Plots of first-order rate constant against cysteamine concentration on pulse radiolysis of N₂O-saturated solutions containing excess of ○, isopropyl alcohol; □, ethanol; and ●, N₂-saturated solutions containing isopropyl alcohol and acetone

in agreement with reaction (24) being rate determining and $k_{24} 3.3 \times 10^8 \text{ l mol}^{-1} \text{ s}^{-1}$. A similar dependence on cysteamine concentration with $k_{24} 3.8 \times 10^8 \text{ l mol}^{-1} \text{ s}^{-1}$ was found when solutions saturated with nitrous oxide rather than nitrogen were used and acetone was omitted (10^{-3}M -ABTS). Furthermore when these nitrous oxide-saturated solutions contained ethanol rather than isopropyl alcohol the ABTS⁺ absorption was still apparent, attributable to RS[•] being formed according to equations (25) and (26).



$$k_{26} 1.7 \times 10^8 \text{ l mol}^{-1} \text{ s}^{-1}$$

(f) Reaction with Solvated Electron ($e^-_{\text{aq.}}$).—In all the above studies the solute concentrations were chosen, taking into account the possible reaction (27). On pulse radiolysis of

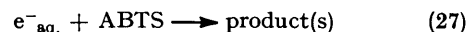

nitrogen-saturated solutions containing t-butyl alcohol (10^{-1}M) the strong characteristic absorption of the solvated electron was observed immediately after the radiation

pulse. In the additional presence of ABTS the absorption at 580 nm decayed exponentially and first-order in ABTS concentration in agreement with $k_{25} 5.1 \times 10^9 \text{ l mol}^{-1} \text{ s}^{-1}$ (Figure 9).

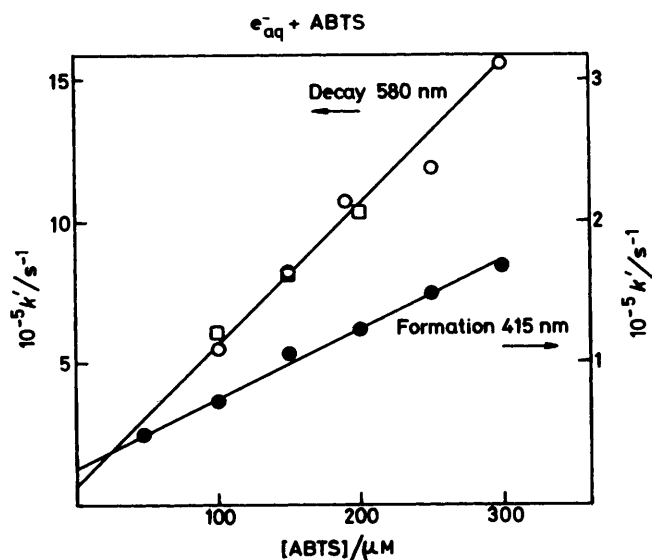
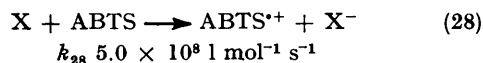
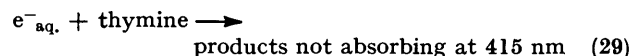

FIGURE 9 Plots of first-order rate constants against ABTS concentration for □, decay of e_{aq}^- absorption at 580 nm and ●, slower formation of the absorption at 415 nm on pulse radiolysis of nitrogen-saturated solutions containing ABTS and excess of t-butyl alcohol. ○ Additional decay points measured using the Hahn-Meitner Institute, Berlin, pulse radiolysis facility by courtesy of Professor K.-D. Asmus

Examination at other wavelengths showed that an absorption indistinguishable from $\text{ABTS}^{+\cdot}$ subsequently grew in over a much longer time scale. The rate of formation of the absorption again increased with increasing ABTS concentration (Figure 9), corresponding to a reaction of the type (28).



In order to confirm that the slow appearance of $\text{ABTS}^{+\cdot}$ was due to the reaction of one or more species X formed from the reaction of e_{aq}^- , the effect of additional solvated electron scavengers on the magnitude of the final $\text{ABTS}^{+\cdot}$ absorption was investigated. On pulse radiolysis of solutions (pH 6.7) containing t-butyl alcohol (0.1M) and ABTS (100 μM) the absorption at 415 nm systematically decreased when increasing concentrations of the pyrimidine base thymine were also present, in agreement with the competing reaction (29) and equation (30) where A° and A are the extinc-



$$A^\circ/A = 1 + \frac{k_{29} [\text{thymine}]}{k_{27} [\text{ABTS}]} \quad (30)$$

tions in the absence and presence of thymine respectively. The kinetic plot is shown (Figure 10). From the slope of the absolute rate constant ratio $k_{29}/k_{27} = 2.9$ was derived. Taking the value $k_{29} = 1.8 \times 10^{10} \text{ l mol}^{-1} \text{ s}^{-1}$ previously published⁸⁵ a value for $k_{27} = 6.2 \times 10^9 \text{ l mol}^{-1} \text{ s}^{-1}$ is obtained.

(g) *Radical-cation Yields.*—In the above studies the

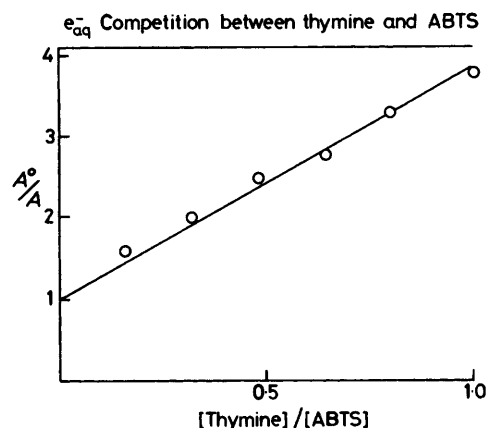

FIGURE 10 Competition plot showing the effect of different thymine concentrations on the absorption at 415 nm produced after 50 μs on pulse radiolysis of N_2 -saturated solutions containing ABTS (100 μM) and excess of t-butanol

yields of radical-cation $\text{ABTS}^{+\cdot}$ formed in most instances varied substantially from that expected on the basis of the proposed mechanisms in spite of the fact that the high radical-cation extinction coefficient ($\epsilon_{415} = 3.6 \times 10^4 \text{ l mol}^{-1} \text{ cm}^{-1}$) enabled low doses to be used so minimising the occurrence of radical-radical reactions. In order to assess the extent that such reactions might be responsible for some of the percentage low yields, the effect of ABTS concentration on the yield of $\text{ABTS}^{+\cdot}$ formed according to (8) was investigated in detail.

A plot of the yield of $\text{ABTS}^{+\cdot}$ found on pulse radiolysis (dose = 5 J Kg^{-1}) of nitrous oxide-saturated solutions containing potassium thiocyanate (0.1M) and ABTS in different concentrations is shown (Figure 11).

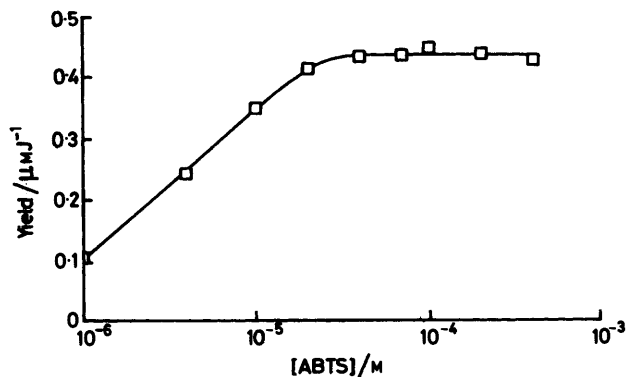

FIGURE 11 Variation of yields of $\text{ABTS}^{+\cdot}$ with ABTS concentration on pulse radiolysis of N_2O -saturated solutions containing ABTS and SCN^- (0.1M). Dose 5 J Kg^{-1}

(h) *Reaction of $\text{ABTS}^{+\cdot}$ with Ascorbate.*—Since the radical-cations of promethazine, chlorpromazine, and metiazinic acid have been shown to react rapidly with ascorbate,^{14, 36–38} it was of interest to investigate whether $\text{ABTS}^{+\cdot}$ behaved similarly.

On pulse radiolysis of N_2O -saturated solutions (pH 7) containing ABTS (10^{-2}M) and ascorbate (100–500 μM) the $\text{ABTS}^{+\cdot}$ absorption at 415 nm was observed immediately after the radiation pulse but decayed exponentially and first-order in ascorbate concentration (Figure 12). Absolute rate constants obtained for kinetic treatment of the data were found to vary with pH over the range, in agreement

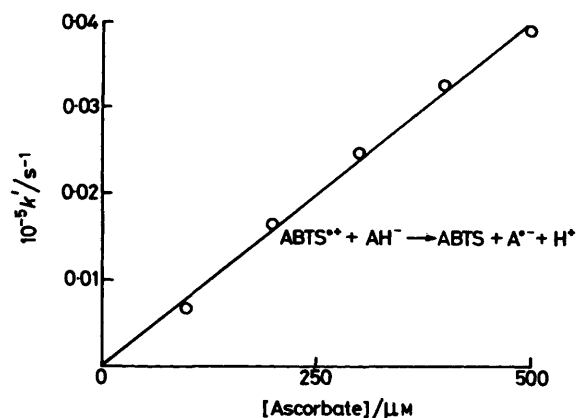
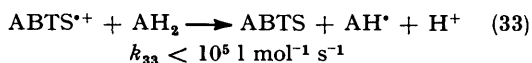
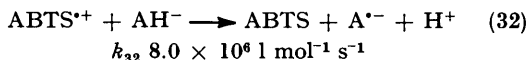
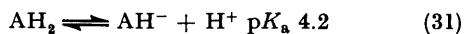

FIGURE 12 Plot of first-order rate constant against ascorbate concentration for decay of 415 nm absorption on pulse radiolysis of N_2O -saturated solutions containing ascorbate and ABTS ($10^{-2}M$; pH 7)

with ascorbic acid being much less reactive than the related anion [reactions (31)–(33)].



DISCUSSION

The present results clearly confirm the previous finding that ABTS can readily undergo one-electron oxidation to yield the related radical-cation with an absorption maximum in the region of 415 nm. Furthermore, the fact that in the chloroform-*t*-butyl alcohol system the yield of radical-cation corresponds to the generally accepted yield for the hydrated electron provides support for the published extinction coefficient $\epsilon_{415} \ 3.6 \times 10^4 \text{ l mol}^{-1} \text{ cm}^{-1}$. The finding that in other systems the experimental radical-cation yields are not what would be expected on the basis of the proposed mechanisms of formation suggests (a) that the radical-cation is not the only immediate product of the proposed reaction of other electrophilic radicals studied, with ABTS, and/or (b) that other reactions of the electrophilic radicals or their precursors occur in competition.

In some systems the best straight line fits of first-order rate constant against ABTS concentration from which rate constants have been derived do not pass through the origin (Table 2 and Figures 5, 8, and 9), and the radical-cation yields drop markedly at low ABTS concentration (Figure 11). This suggests that radical-radical reactions are at least partly responsible for the reduced yields at low ABTS concentrations. However the fact that the theoretical yield is not obtained at ABTS concentration in the range where the yield remains constant, *e.g.* $>50 \mu M$ in the case of $(SCN)_2^{•-}$ (Figure 11) suggests that other products are also formed in such reactions. The occurrence of separate simultaneous reaction pathways leading to different products during a particular radical-molecule reaction is not uncommon

particularly when macromolecules are involved. Even in the case of relatively small molecules such as phenothiazines (PZ) or tryptophan (trp) electron transfer and radical addition can take place simultaneously [reactions (34)–(37)]^{37,39} Similar reactions could well occur with ABTS.

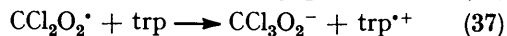
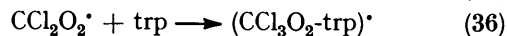
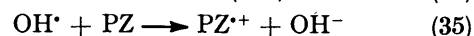
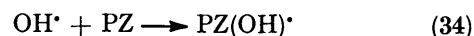

In the case of $OH^•$ the yield of $ABTS^{•+}$ is only 58% of that expected if electron transfer occurred exclusively. The value of the absolute rate constant determined directly is supported however by the close similarity of the values determined for the reaction of $OH^•$ with other solutes with those quoted in the literature (Table 1).

Clearly ABTS has considerable potential as a reference solute in the determination of $OH^•$ rate constants with the proviso that the radical formed from the competing solute does not itself react rapidly with ABTS. Preliminary experiments show that reactions of this type do occur with ethylene glycol and glucose in agreement with previous findings that organic radicals containing hydroxy-groups α and β to the carbon radical centre can eliminate water to form oxidising species [reactions (38)–(40)]^{17,40,41}

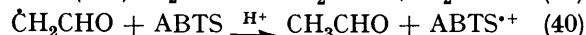
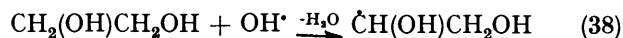

The observation of the rapid reaction of thiyl radicals from cysteamine, cysteine, and glutathione with ABTS is particularly relevant to the role of thiols in free-radical protection. Whether protection occurs by hydroxyl-radical scavenging or by hydrogen atom or electron transfer, thiyl radicals will be formed.²⁰ Little attention has been paid to the possible subsequent reactions of these radicals except in so far as they may react with oxygen, thiol anions, or with themselves according to reactions (41)–(43).^{32,42}



The fact that thiyl radicals can react with ABTS by an electron-transfer mechanism and that the resulting radical-cation $ABTS^{•+}$ can itself react with ascorbate has led to consideration of the possibility of a large number of related reactions of thiyl radicals with other nucleophiles. Preliminary results have already shown that thiyl radicals can react rapidly with phenothiazines.⁴³ Furthermore their direct reactions with ascorbate has been followed by observing the formation of the ascorbate radical-anion absorption at 360 nm with $k_{44} = 1.3 \times 10^9$ and $5.5 \times 10^8 \text{ l mol}^{-1} \text{ s}^{-1}$ for cysteamine and glutathione respectively.⁴⁴

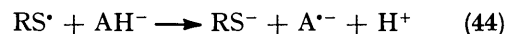

Clearly such reactions have considerable implications in biochemistry generally. With reference to free-radical protection, the observed value of the rate constants of 'repair' of isopropyl radicals, $k_{24} = 3.3$ and $3.8 \times 10^8 \text{ l mol}^{-1} \text{ s}^{-1}$, and of ethanol radicals, $k_{26} = 1.7 \times 10^8 \text{ l mol}^{-1} \text{ s}^{-1}$, are in good agreement with published values³³ of 4.4×10^8 and $1.4 \times 10^8 \text{ l mol}^{-1} \text{ s}^{-1}$, respectively.

The appearance of the radical-cation absorption following the reduction of ABTS by e^-_{aq} is particularly intriguing. Two explanations are possible. First the species X responsible for the oxidation of ABTS is the one-electron reduced product $\text{ABTS}^{\cdot-}$, or its protonated form $\text{ABTS}(\text{H})^{\cdot}$ [reaction (45)]. Alternatively the



reduced form may rapidly dissociate with fission of the nitrogen-nitrogen azino bond to form a benzthiazoline radical, BTSN^{\cdot} , and its related anion $\text{BTSN}^{\cdot-}$ [reactions (46) and (47)].

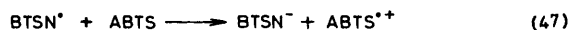
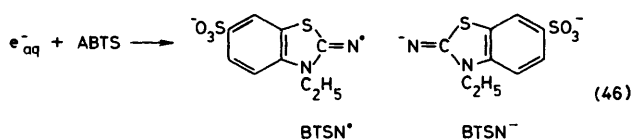

Whatever the actual mechanism, the fact that the value for $k_{27} = 5.1 \times 10^9 \text{ l mol}^{-1} \text{ s}^{-1}$, determined directly from the decay of the e^-_{aq} absorption, agrees closely with the value $k_{25} = 6.2 \times 10^9 \text{ l mol}^{-1} \text{ s}^{-1}$, determined by competition with thymine, supports the conclusion that $\text{ABTS}^{+\cdot}$ can be formed from reactions of e^-_{aq} , and that the observations are not the result of artefacts. Interestingly when nitrate ion rather than thymine was used as a possible competitive electron scavenger⁴⁵ simple competition was not observed. Indeed when nitrate was present at concentrations that should have scavenged almost all the solvated electrons, the $\text{ABTS}^{+\cdot}$ absorption remained. Furthermore the appearance of the absorption was first-order in ABTS concentration in agreement with reactions (48) and (49).

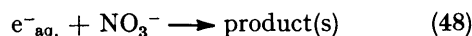

$$k_{49} = 3.8 \times 10^7 \text{ l mol}^{-1} \text{ s}^{-1}$$

The reaction of e^-_{aq} with nitrate ion has been studied by several workers⁴⁵⁻⁴⁸ and pulse radiolysis and stationary-state evidence has been provided for the formation of $\text{NO}_3^{\cdot 2-}$ and subsequently $\text{NO}_3\text{H}^{\cdot-}$ and NO_2 according to reactions (50)–(52). The data obtained to date do

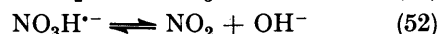
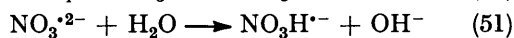
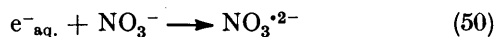

not permit the nitrate-derived species responsible for the one-electron oxidation of ABTS to be distinguished. Clearly ABTS has considerable potential as a reference

solute in the study of electron-transfer reactions in which a free radical is the one-electron oxidant. Further experiments are in progress.

Note added in proof: Since the manuscript was submitted we have found that k_{32} varies with $[\text{ABTS}]$; e.g. at $1 \times 10^{-3} \text{ M}$ ABTS, $k_{32} = 3 \times 10^7 \text{ mol}^{-1} \text{ s}^{-1}$. In addition, a recent paper report one-electron transfer equilibria between thiyl and phosphite free radicals: K. Schafer and K.-D. Asmus, *J. Phys. Chem.*, 1981, **85**, 852.

Financial support from the Cancer Research Campaign and the Medical Research Council and helpful discussions with L. Forni, J. Monig, V. Mora-Arellano, and A. J. F. Searle are gratefully acknowledged. We are indebted to Dr. S. M. Cockle whose seminar on salivary peroxidases inspired this work.

[1/1803 Received, 19th November, 1981]

REFERENCES

- K. B. Patel and R. L. Willson, *J. Chem. Soc., Faraday Trans. 1*, 1973, 814.
- P. M. Wood, *FEBS Lett.*, 1974, **44**, 22.
- Y. A. Ilan, D. Miesel, and Cr. Czapski, *Isr. J. Chem.*, 1974, **12**, 89.
- R. L. Willson, W. A. Cramp, and R. M. J. Ings, *Int. J. Radiat. Biol.*, 1974, **26**, 557.
- D. Meisel and P. Neta, *J. Am. Chem. Soc.*, 1975, **97**, 5198.
- D. Meisel and G. Czapski, *J. Phys. Chem.*, 1975, **79**, 1503.
- R. F. Anderson, *Ber. Bunsen. Phys. Chem.*, 1976, **80**, 969.
- P. Wardman and E. D. Clarke, *J. Chem. Soc., Faraday Trans. 1*, 1976, 1377.
- J. A. Farrington, E. J. Land, and A. J. Swallow, *Biochim. Biophys. Acta*, 1980, **590**, 273.
- R. F. Anderson, *Biochim. Biophys. Acta*, 1980, **590**, 277.
- R. L. Willson, *Trans. Biochem. Soc.*, 1974, 1082.
- R. L. Willson, *Chem. Ind. (London)*, 1977, 183.
- K.-D. Asmus, D. Bahnemann, J. Monig, A. Searle, and R. L. Willson in 'Studies in Physical and Theoretical Chemistry,' eds. H. E. Edwards, S. Navaratnam, B. J. Parsons, and E. O. Phillips, Elsevier, Amsterdam, 1979, vol. 6, pp. 39–47.
- J. S. Mahood, J. E. Packer, A. J. F. Searle, R. L. Willson, and B. S. Wolfenden in 'Phenothiazines and Structurally Related Drugs: Basic and Clinical Studies,' eds. Usdin, Eckert, and Forest, Elsevier, Amsterdam, 1980, pp. 99–102.
- D. Bahnemann, K.-D. Asmus, and R. L. Willson, ref. 14, pp. 99–102.
- D. Bahnemann, K.-D. Asmus, and R. L. Willson, *J. Chem. Soc., Perkin Trans. 2*, 1981, 890.
- S. Steenken, *J. Phys. Chem.*, 1979, **83**, 595.
- S. Fujita and S. Steenken, *J. Am. Chem. Soc.*, 1981, **103**, 2540.
- R. E. Childs and W. G. Bardsky, *Biochem. J.*, 1975, **145**, 93.
- R. L. Willson in 'Biochemical Mechanisms of Liver Injury,' ed. T. F. Slater, Academic Press, London, 1978, p. 123.
- R. L. Willson in 'Free Radicals, Lipid Peroxidation and Cancer,' eds. E. C. H. McBrien and T. F. Slater, Academic Press, London, 1982, pp. 275–303.
- R. L. Willson, *Int. J. Radiat. Biol.*, 1970, **17**, 349.
- R. L. Willson, C. L. Greenstock, G. E. Adams, R. Wageman, and L. M. Dorfman, *Int. J. Radiat. Phys. Chem.*, 1971, **3**, 211.
- R. L. Willson and T. F. Slater in 'Fast Processes in Radiation Chemistry and Biology,' eds. G. E. Adams, E. M. Fielden, and B. D. Michael, The Institute of Physics, Wiley, 1973, p. 147.
- R. L. Willson, *Trans. Biochem. Soc.*, 1973, **1**, 929.
- J. E. Packer, T. F. Slater, and R. L. Willson, *Life Sci.*, 1978, **23**, 2617.
- J. E. Packer, T. F. Slater, and R. L. Willson, *Nature*, 1979, **278**, 737.
- J. E. Packer, R. L. Willson, D. Bahnemann, and K.-D. Asmus, *J. Chem. Soc., Perkin Trans. 2*, 1980, 296.
- J. E. Packer, J. S. Mahood, V. O. Mora-Arellano, T. F. Slater, R. L. Willson, and B. S. Wolfenden, *Biochem. Biophys. Res. Commun.*, 1981, **98**, 901.

- ³⁰ W. T. Dixon, R. O. C. Norman, and A. J. Buley, *J. Chem. Soc.*, 1964, 3625.
- ³¹ D. Veltwisch, E. Janata, and K.-D. Asmus, *J. Chem. Soc., Perkin Trans. 2*, 1980, 146.
- ³² G. E. Adams, G. S. McNaughton, and B. D. Michael in 'Chemistry of Ionization and Excitation,' eds. G. R. A. Johnson and G. Scholes, Taylor and Francis, London, 1967, pp. 281—293.
- ³³ G. E. Adams, G. S. McNaughton, and B. D. Michael, *Trans. Faraday Soc.*, 1968, **64**, 902.
- ³⁴ J. L. Redpath, *Radiat. Res.*, 1973, **54**, 364.
- ³⁵ G. Scholes, P. Show, R. L. Willson, and M. Ebert in 'Pulse Radiolysis,' eds. M. Ebert, J. P. Keene, A. J. Swallow, and J. H. Baxendale, Academic Press, London, p. 151.
- ³⁶ E. Pelizzetti, D. Meisel, W. A. Mulac, and P. Neta, *J. Am. Chem. Soc.*, 1979, **101**, 6954.
- ³⁷ D. Bahnemann, K.-D. Asmus, and R. L. Willson, *J. Chem. Soc., Perkin Trans. 2*, 1981, 890.
- ³⁸ D. Bahnemann, K.-D. Asmus, and R. L. Willson, to be published.
- ³⁹ J. E. Packer, J. S. Mahood, R. L. Willson, and B. S. Wolfenden, *Int. J. Radiat. Biol.*, 1981, **39**, 135.
- ⁴⁰ A. L. Buley, R. O. C. Norman, and R. J. Pritchett, *J. Chem. Soc. B*, 1966, 849.
- ⁴¹ K. M. Bansal, M. Gratzel, A. Henglein, and E. Janata, *J. Phys. Chem.*, 1973, **77**, 16.
- ⁴² K. Schafer, M. Bonifacic, D. Bahnemann, and K.-D. Asmus, *J. Phys. Chem.*, 1978, **82**, 2777.
- ⁴³ L. Forni, J. Monig, T. F. Slater, R. L. Willson, D. Bahnemann, and K.-D. Asmus, unpublished results.
- ⁴⁴ V. O. Mora-Arellano, J. Monig, B. S. Wolfenden, and R. L. Willson, to be published.
- ⁴⁵ A. Appleby, G. Scholes, and M. Simic, *J. Am. Chem. Soc.*, 1963, **85**, 3891.
- ⁴⁶ M. Daniels and E. Wigg, *J. Phys. Chem.*, 1967, **71**, 1024.
- ⁴⁷ M. Ottolenghi and J. Rabani, *J. Phys. Chem.*, 1968, **72**, 593.
- ⁴⁸ M. Gratzel, A. Henglein, and S. Taniguchi, *Ber. Bunsen. Phys. Chem.*, 1970, **74**, 292.