

Elimination and Addition Reactions. Part 37.¹ A Comparative Study of Electronic, Steric, and Solvent Effects upon Reactivity in Additions of Benzenesulphenyl Chloride to Alkenes

G. Alun Jones and Charles J. M. Stirling *

The School of Physical and Molecular Sciences, University College of North Wales, Bangor, Gwynedd LL57 2UW

Norman G. Bromby

I.C.I. Organics Division, Blackley, Manchester M9 3DA

Rates of additions of benzenesulphenyl chloride to 35 alkenes in several solvents have been measured, and the products of the reactions have in most cases been identified. Results for arylalkenes broadly confirm previous work, but the responses to solvent change are not uniform throughout. The reactivity of bridged cycloalkenes is substantially greater than that of cycloalkenes, but that of cyclo-pentadiene dimer is anomalously small. For allylic substrates, the correlation of electron density at the double bond with reactivity is shown by a rectilinear relationship between $\log k$ and σ_r . Allyl iodide and allyl alcohol are anomalously more reactive than this correlation would predict; this is accounted for by solvation and by internal solvation effects respectively.

Addition of sulphenyl halides to alkenes [equation (i)] has been a familiar and much studied reaction, from the pioneering studies of Kharasch and his co-workers in the 1950s to the present time.²

Previous work has been concerned mainly with the reactivity of 2,4-dinitrobenzenesulphenyl halides and other aromatic sulphenyl halides in which the aromatic nucleus bears an electronegative substituent. This earlier work has established the following general features of the reaction.

(1) Electron density in the carbon-carbon double bond is an important factor in determining the reactivity of alkenes towards sulphenyl halides. Alkyl substitution increases reactivity, but to a very much lesser extent than for electrophiles such as chlorine.³ For nuclear-substituted styrenes, ρ values are negative,⁴ but less so than for halogen additions. ρ^* Values for acyclic alkenes are negative [only alkyl substituents (DNSCl † in acetic acid) investigated],⁵ but for cyclohexenes with a variety of polar 4-substituents a rectilinear $\rho_r\sigma_r$ plot with slope -2.88 is obtained.⁶ Aryl⁷ and vinyl⁸ substituents deactivate.

(2) Addition of sulphenyl halides to alkenes is subject to steric retardation, but effects are generally small. *Z*- β -Alkylation in styrenes lowers reactivity, but *E*- β -alkylation is accelerative,^{7a} and so is α -alkylation.^{7c} In simple alkenes, alkylation at the carbon-carbon double bond produces small effects which are a compromise between weak increase of π -nucleophilicity and steric hindrance.⁸ (*Z*)-Alkenes are generally less reactive than (*E*)-alkenes^{9,10} but (*Z*)-but-2-ene is slightly more reactive than the *E*-isomer¹¹ and in 1,2-di-*t*-butylethene the *Z/E* ratio¹² rises to 10.⁵

(3) Reactivity is not very sensitive to strain in the alkene; cyclopentene is a little more reactive than cyclohexene.^{7c}

(4) Alkenesulphenyl halide reactions are very sensitive to alteration of medium polarity, as reflected for example by E_T values.¹³ For additions of DNSCl to cyclohexene, for example, the rate constant increases by a factor of 3×10^3 on transfer from carbon tetrachloride to nitrobenzene.¹⁴

All these characteristics have been regarded as consistent with, as the first step of the reaction, formation of an intermediate episulphonium salt in which the configuration of the original alkene is preserved.

The second stage of the reaction is considered to involve

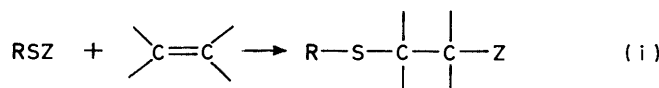

nucleophilic ring fission by the counter ion (usually halide). The factors which determine the regio- and stereo-specificity of this second stage are as follows.

(a) Substituents capable of exerting $-I$ or $-M$ effects direct (although not exclusively) nucleophilic attack to the position of attachment of the substituent, resulting in Markownikoff orientation. This generalisation breaks down when, as for sulphonyl substituents, steric effects become dominant.¹⁵

(b) Steric effects on orientation are substantial. Simple alkenes give predominantly anti-Markownikoff orientation to an extent that varies with the S-group, and the preference for anti-Markownikoff orientation is increased by bulky substituents on the double bond.¹⁶

A balance between electronic factors in (a) and steric factors in (b) is struck for alkenes with carbanion-stabilising groups attached directly to the carbon-carbon double bond.¹⁵

(c) Additions are stereospecifically *trans*^{9,10,17} (with one exception¹⁸).

Until recently the agreed view of alkenesulphenyl halide reactions was that of rate-determining formation of an episulphonium intermediate with subsequent stereospecific attack by the counter ion with a regio-specificity dependent upon balance between electronic and steric factors.

This widely held 'episulphonium' view has been directly challenged by Smit *et al.*,^{19a} who adduce information against the intermediacy of an episulphonium ion with high charge localisation on sulphur. Instead they suggest formation of an intermediate which adopts a sulphurane, intimate ion-pair, or solvent-separated ion pair structure according to the nature of the alkene, sulphenyl halide, and solvent. This conclusion is supported by *ab initio* SCF-MO calculations.^{19b}

Against this background of considerable previous work, we have investigated reactions of benzenesulphenyl chloride with 35 alkenes with respect to their rates of formation, their products, and their susceptibility to change of solvent. Our general objective was to assess, in connection with rubber vulcanisation, the reactivity of a wide range of simple alkenes towards sulphur electrophiles in a variety of environmental (\rightleftharpoons solvent) conditions. The nature of sulphur-containing

† 2,4-Dinitrobenzenesulphenyl chloride.

Table 1. Rate constants for reactions of benzenesulphenyl chloride with styrenes

No.	Styrene: R ¹ R ² C=CR ³ Ph	10 ³ k (CCl ₄) ^a	k(CH ₂ Cl ₂) ^a	k(CH ₂ Cl ₂)/ k(CCl ₄)
(1)	R ¹ = R ² = R ³ = H	7.07	65.4	9 250
(2)	R ¹ = R ² = R ³ = H; <i>p</i> -MeOC ₆ H ₄ for Ph	40.8		
(3)	R ¹ = R ² = H, R ³ = Me	13.7		
(4)	R ¹ = R ² = H, R ³ = Ph	0.51	4.31	8 450
(5)	R ¹ = Ph, R ² = R ³ = H (<i>E</i>)	<10 ⁻²	0.35	>3 500
(6)	R ¹ = Ph, R ² = R ³ = H (<i>Z</i>)	0.49	0.49	1 000
(7)	R ¹ = Ph, R ² = Me, R ³ = H	0.08	0.50	6 300
(8)	R ¹ = R ² = Ph, R ³ = H	<i>b</i>	<i>b</i>	
(9)	R ¹ = R ² = R ³ = Ph	<i>b</i>	<i>b</i>	

^a Units: dm³ mol⁻¹ s⁻¹ at 25.4 °C. ^b No reaction.

species in rubber vulcanisation is poorly understood²⁰ and the incorporation of nucleophilic alkenes in rubber vulcanisation mixes offered the possibility of modifying the properties of vulcanisates.

Despite the large amount of work on sulphenyl halide-alkene reactions, it is difficult to obtain a clear overview of them. This is because a limited range of alkenes has been studied in any one combination of halide and solvent and because product analyses have by no means always accompanied kinetic measurements.

Results and Discussion

Benzenesulphenyl chloride has been used throughout this work. The alkenes studied are arranged in the categories of styrenes (Table 1), strained and unstrained cyclic alkenes (Table 2), allylic alkanes (Table 3), and alkenes with substituents attached directly to the double bond (Table 4). In most reactions, carbon tetrachloride and dichloromethane have been compared as solvents, but some comparisons with cyclohexane have also been made.

Kinetics have been determined spectroscopically by following disappearance of sulphenyl halide. Regiospecificity of reactions has been determined by proton magnetic resonance spectroscopy; in many cases the stereochemistry was difficult to be certain about, but in only one previous instance¹⁸ has other than *trans* stereochemistry been found.

Reactivity of Styrenes.—The data of Table 1 embrace a reactivity range of about 10⁴. Aryl-substituted alkenes are substantially less reactive than simple alkenes; the rate constant for addition to styrene (1) is less than one tenth that of addition to hex-1-ene (19) (Table 3). If α -methylstyrene (3) is to be regarded as a closer analogue of hex-1-ene, then a factor of five is appropriate. This important observation has been recorded frequently in other sulphenyl halide-halide systems,²¹ and clearly shows that significant localisation of positive charge on carbon is not a feature of the transition state of the rate-determining step. A small negative Hammett ρ value for the reaction was obtained^{4,7c} earlier for the DNSCl-acetic acid reactions; in our system the rate constant for *p*-methoxystyrene (2) indicates a small negative value of ρ .

It is clear that electron density in the carbon-carbon double bond is an important factor in determining reactivity. Successive attachment of phenyl groups reduces reactivity to

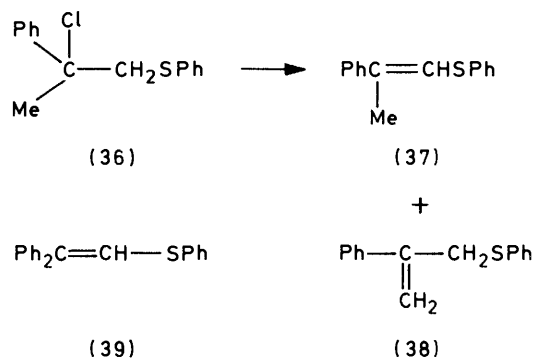
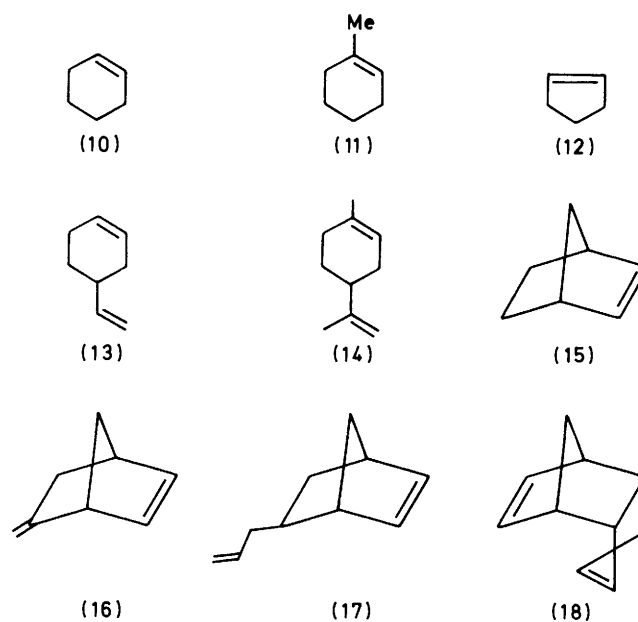
**Table 2.** Rate constants^a for reactions of benzenesulphenyl chloride with cyclic alkenes

Alkene	10 ³ k(CCl ₄)	k(CH ₂ Cl ₂)	k(CH ₂ Cl ₂)/ k(CCl ₄)
(10)	150 ^b	172 ^c	1 124
(11)	62		
(12)	1 040	1 750	1 680
(13)	166		
(14)	95		
(15)	12 300	1.99 ^d	
(16)	17 900	2.38 ^d	
(17)	5 900		
(18)	73		

^a Units dm³ mol⁻¹ s⁻¹ at 25.4 °C. ^b 1.01 × 10⁻³ in cyclohexane. ^c Value in ref. 13, 260. ^d 10k (cyclohexane).

vanishing point: no reaction was detected for tri- (8) and tetra- (9) phenylethenes, and attachment of an α -phenyl group (4) to styrene depresses reactivity more than tenfold. A similar, though smaller, ratio has been obtained for DNSCl-acetic acid reactions.^{7c}

1,2-*Z*-Disposition of phenyl groups (6) produces the same reactivity as the unsymmetrical disposition (4), and again this is in accord with formation of an intermediate with positive character on sulphur. No reaction of the *E*-alkene (5) in dichloromethane was detected; this result recalls the substantial differential steric effect encountered previously for

Table 3. Rate constants for reactions of benzenesulphenyl chloride with allylic derivatives

Alkene	$10^3 k(\text{CCl}_4)^a$	$k(\text{CH}_2\text{Cl}_2)^a$	$k(\text{CH}_2\text{Cl}_2)/k(\text{CCl}_4)$	$k(\text{cyclohexane})$	$k(\text{CCl}_4)/k(\text{cyclohexane})$
(19)	98.6	37.4	379		
(20)	15.3	4.27	279		
(21)	0.76	0.24	315		
(22)	0.47	0.23	489		
(23)	11.9	0.90	76	2.3×10^{-3}	52
(24)	0.18	0.032	177		
(25)	3.36	0.99	294	8.6×10^{-5}	39
(26)	36.6	10.2	278		
(27)	245 ^c			0.15	1.7

^a At 25.4 °C; units: $\text{dm}^3 \text{mol}^{-1} \text{s}^{-1}$. ^b Value in ref. 13, 36.8. ^c Variable with [alkene]; see text.

Z- and *E*-alkenes with bulky substituents.¹² Interestingly, with DNSCl, alkene (5) is rather more reactive than alkene (6).⁷

The solvent effect on reactions with styrenes is striking; the dichloromethane: carbon tetrachloride ratios are all in the range 10^3 – 10^4 : 1, in accord with the substantially greater polarity of CH_2Cl_2 than of CCl_4 as derived from several polarity scales.^{13b} This high sensitivity implies a substantially polar transition state irrespective of the nature of the alkene, but values of this ratio are higher (about tenfold) than for most other alkenes studied. Relative rates for styrene *versus* other arylalkenes (Table 1) are insensitive to solvent change with the notable exception of (*Z*)-stilbene (6), which is ten times more reactive relative to styrene in carbon tetrachloride than dichloromethane. Rather few solvent comparisons have been made for sulphenyl halide–alkene reactions,^{13b,14} and none, so far as we are aware, for one sulphenyl halide as a function of alkene. The substantial difference in relative rates occasioned by solvent change as between styrene and (*Z*)-stilbene (6) strongly suggests a solvent steric effect. For *p*-chlorobenzenesulphenyl chloride–tetrachloroethylene reactions, the reactivity ratio for these alkenes is 16.7: 1, in line with the carbon tetrachloride results.^{7a}

The products from styrene were obtained in high yields and were formed predominantly according to Markownikoff orientation. The initial product (36) from α -methylstyrene lost hydrogen chloride on working up to give the isomers (37) and (38), the former *S*-conjugated isomer predominating as expected.

The adduct from 1,1-diphenylethene (4) spontaneously eliminated hydrogen chloride to give (39). A similar observation has been made for the methanesulphenyl chloride reaction.¹⁶

Cyclic Alkenes (Table 2).—The general picture for these alkenes, when they are not bridged, is that of insensitivity to structural change; relative reactivity for reactions in carbon tetrachloride is spanned by a factor of 20. Cyclohexene has virtually the same reactivity as hex-1-ene (Table 3) in carbon tetrachloride, and alkenes with an additional substituent on

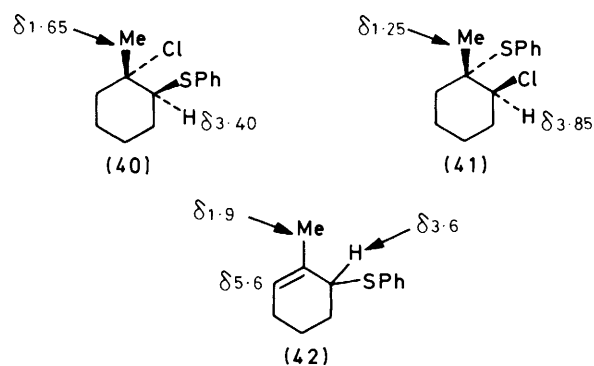

the carbon–carbon double bond are again somewhat less reactive, pointing clearly to a rate-determining transition state with little localisation of charge on carbon.

For the cyclic non-conjugated dienes (13) and (14), possibilities for both *exo*- and *endo*-cyclic addition exist. *Exo*-cyclic addition was preferred in each case by a small factor and the reactivity of the exocyclic double bond is close in each case to that of hex-1-ene (19). Additions of 2,4-DNSCl to limonene (14) have been investigated previously;²² double addition was observed, but products were not characterised.

Adducts from cycloalkenes with alkyl substitution at the double bond were very prone to isomerisation. The initial Markownikoff (40) (46%): anti-Markownikoff (41) (54%) mixture from 1-methylcyclohexene (11) changed on standing to 85%: 15%. The product (40) lost hydrogen chloride, giving 2-methyl-3-phenylthiocyclohexene (42).

The reactivities of non-conjugated bridged dienes (16) and (17) are much greater than that of cyclohexene and similar to that of norbornene (15). Consistently, the ¹H n.m.r. spectrum of the product mixture from (17) shows much preponderant addition to the endocyclic carbon–carbon double bond. The product from (16) showed no alkene proton signals in the n.m.r. and we assign structure (44; R = Me) to it. The formation of the same diastereoisomeric mixture has recently been

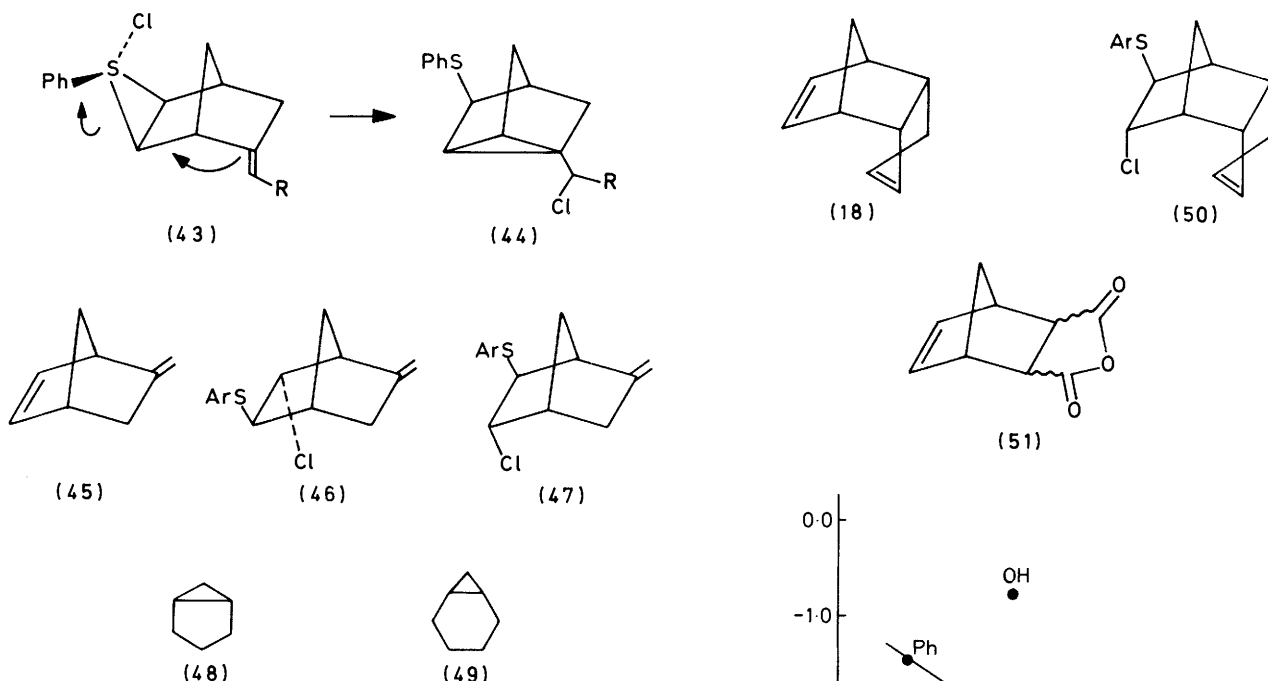

reported by Garratt and his co-workers,²³ who found reactions to be very rapid in dichloromethane. They also made a detailed study of reactions with methylenenorbornene (45), and characterised the bicyclic adducts (46) and (47) as well as the tricyclic adduct (44; R = H).

Presumably, initial addition to the endocyclic double bond is followed by an intramolecular displacement which is itself faster than subsequent addition of sulphenyl halide to the exocyclic double bond or carbon-chlorine bond formation in the original thiiran species. Similar behaviour is shown in addition of methanesulphenyl chloride (but not DNSCl²⁴) to (*Z,E*)cyclodeca-1,5-diene.²⁵ In the reaction with (17), the non-occurrence of five-membered-ring (primary) and six-membered-ring (secondary) carbocation bridging is notable.

The higher reactivities of the strained cycloalkenes [cyclopentene and the bridged cycloalkenes (15)–(17)] in comparison with cyclohexene is to be attributed to the higher ground state energies of these alkenes.²⁶ The strain induced in formation of the fused episulphide intermediate is presumably also smaller for the rigid cyclopentene and norbornene systems. The enthalpy difference between cyclopentene (12) and bicyclo[3.1.0]hexane (48) is substantially smaller than that between cyclohexene and bicyclo[4.1.0]hexane (49).²⁷

The norbornene : cyclohexene ratio of 82 : 1 is rather larger than that (33) obtained earlier for DNSCl.^{7c} The former result was considered to be incompatible with any delocalisation of charge on carbon in a non-classical species, which should produce a much larger effect. It is particularly striking that cyclopentadiene dimer (18), with carbon-carbon double bonds in structural environments similar to those in norbornene and cyclopentene, respectively, should be less reactive than these by factors of 159 and 14, respectively. Cyclopentadiene dimer has the *endo*-structure (18). Adduct (50) is formed from norbornene (15) and benzenesulphenyl chloride (this work) and from toluene-*p*-sulphenyl chloride;¹⁶ if the same course of reaction is followed with cyclopentadiene dimer, the substantially lower reactivity might be explained by interference by the cyclopentenyl moiety with carbon-chlorine bond formation in the thiiran intermediate on the underside of the molecule. This, however, would be true only if there were a change in rate-determining step. Alternatively,

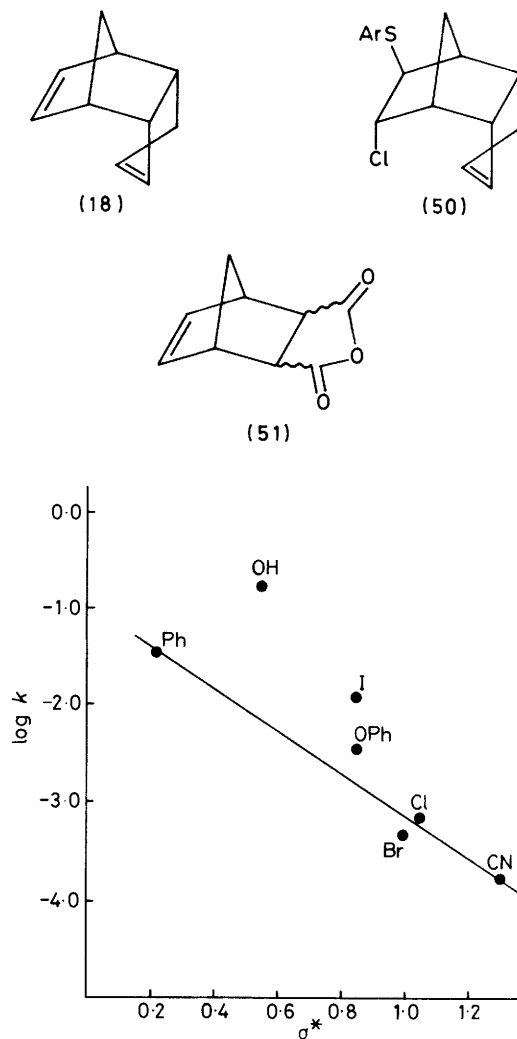
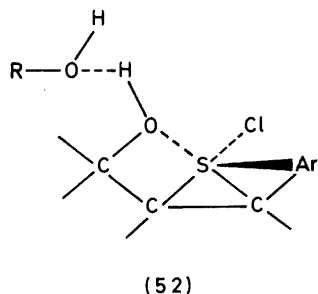

Figure. Plot of $\log k$ against σ^* for addition of benzenesulphenyl chloride to $XCH_2-CH=CH_2$ in dichloromethane at 25.4 °C

the proximity of the two carbon-carbon double bonds may depress their respective nucleophilicities in a manner not at present understood. No studies of other electrophilic additions to cyclopentadiene dimer have been made which would allow significant comparisons with other alkenes. In this connection, however, the reactivity of the anhydrides (51) has been studied;⁶ the ratio of reactivities of the *exo*- to the *endo*-isomer is 56 : 1 for additions of 2,4-dinitrobenzenesulphenyl chloride, and perhaps a similar field effect is operating in both cases.

A striking feature of the reactivity of the bridged non-conjugated cycloalkene (17) is that while reactivity is much greater than for hex-1-ene, for example, nevertheless a significant proportion (*ca.* 30%) of addition occurs at the exocyclic double bond.

Allylic Substrates (Table 3).—All the substrates bear $-I$ substituents, and on the basis of experience with styrenes (Table 1) would be expected to be less reactive than hex-1-ene, which we take as the standard of comparison. This general pattern is observed; in the series of halides, 4-bromobut-1-ene is substantially more reactive than 3-bromobut-1-ene. Surprisingly, however, 3-chlorobut-1-ene is more reactive than the bromide. A Taft plot of $\log k_{\text{addition}}$ vs. $\sigma^*_{\text{CH}_2\text{Z}}$ is rectilinear (Figure) with slope $\rho^* = -2.1$. A rectilinear $\sigma^*\rho^*$



plot has similarly been obtained for nuclear-substituted allyl-benzenes²⁸ and by Collin *et al.*^{7c} for addition of DNSCl to a range of allylic derivatives. In the latter case, $\rho^* = -1.89$ and neither allyl iodide nor allyl alcohol was investigated. Two substantial deviations, with $Z = \text{OH}$ or I , are particularly notable. Reactions with allyl alcohol were carried out using 10–20 mol excess of alkene over sulphenyl halide. We believe that with substantial excesses of alcohol present, the solvating power of the medium, to which the rate constants have been seen to be very sensitive, is altered. This is confirmed in that change of alkene concentration from a 10- to a 20-fold excess nearly doubled the second-order rate constant. This effect can be simulated by addition of a primary alcohol to the medium. In reactions of hex-1-ene, propanol has been added in concentrations similar to those used in reactions of allyl alcohol with benzenesulphenyl chloride under pseudo-first-order conditions. A trend of increasing rate constants with increasing propanol concentration is found (Table 8), which is very similar to that found for allyl alcohol (Table 7). In addition to this intermolecular solvent effect, however, a specific effect of a hydroxy group is indicated by the ratios of rate constants obtained in carbon tetrachloride and in cyclohexane. A substantial value of the ratio is found for reaction with cyclohexene (159 : 1) while for allyl iodide (52 : 1) and phenyl allyl ether (39 : 1) the lower values perhaps indicate some interaction with the substituent in the formation of the thiiranoïd group. For allyl alcohol, the value of 1.7 : 1 suggests a much lower requirement for solvation of the stabilisation of the transition state, such stabilisation being provided intramolecularly. In this connection, when reactions with allyl alcohol are carried out with similar concentrations of alkene and sulphenyl halide, second-order plots were not rectilinear. These overall observations are consistent with a combination of intramolecular and intermolecular effects (52); It is also striking in this connection that cyclohexene and allyl alcohol have similar reactivities in carbon tetrachloride, but in the poorer solvent cyclohexane, allyl alcohol is more than one hundred times as reactive.

Products of reactions of sulphenyl halides with tertiary allylic benzyl alcohols have been studied before;²⁹ anti-Markownikoff and Markownikoff products are found together with the products of aryl migration. In the presence of basic catalysts, nucleophilic attack on sulphenyl halides occurs through oxygen and not the carbon-carbon double bond.³⁰

Vinylic Substrates (Table 4).—All substrates with electron-acceptive conjugative groups are much less reactive than hex-1-ene.

Derivatives of propenoic acid, $\text{CH}_2=\text{CHCOR}$, have been studied in reactions with benzenesulphenyl chloride;³¹ the order of reactivity is $\text{R} = \text{NPh} > \text{OEt} > \text{OMe} > \text{OH}$.

For substrates with cyano and carbonyl substitution on the carbon-carbon double bond, ratios of 10^{-3} – 10^{-4} are typical. Again this is consistent with moderate sensitivity to electron density in the carbon-carbon double bond. By comparison,

Table 4. Addition of benzenesulphenyl chloride to vinylic substrates

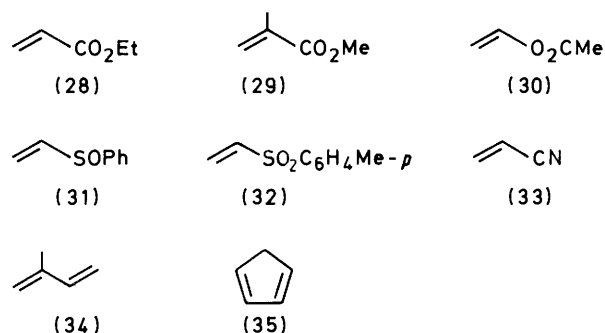

Alkene	$10^3 k(\text{CCl}_4)^{a,b}$	$k(\text{CH}_2\text{Cl}_2)^{a,b}$	$k(\text{CH}_2\text{Cl}_2)/k(\text{CCl}_4)$
(28)		2.75×10^{-2}	
(29)		5.28×10^{-2}	
(30)	0.40	0.32	800
(31)		4.3×10^{-3}	
(32)		3.86×10^{-4}	
(33)		$< 10^{-5}$	
(34)	4.14		
(35)	24.9		

^a Units: $\text{dm}^3 \text{mol}^{-1} \text{s}^{-1}$. ^b At 25.4 °C.

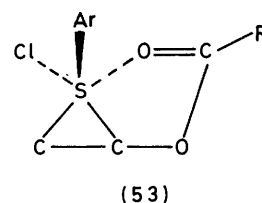

rates of addition of bromine, for example, show much greater sensitivity.³

Isoprene (34) and cyclopentadiene (35) are included in Table 4 as the additional functional group is directly attached to the carbon-carbon double bond. With both these substrates, the possibility of 1,4-addition arises and in neither case is it found. These results are in accord with the earlier observations.³² Again this behaviour points to little development of positive charge on carbon, and the substantially lower reactivity of these dienes in comparison with hex-1-ene is consistent with this picture. Kresze and Kosbahn³³ found predominant Markownikoff addition, but Markownikoff 3,4-addition (22%) occurs together with 1,4-*trans* (15%) addition. In reactions of isoprene with *p*-chlorobenzenesulphenyl chloride in *sym*-tetrachloroethane, only 1,2-addition is observed, with a slight preference for the less substituted double bond.³⁴

The reactivity of the substrates in Table 4 is not controlled simply by electrostatic effects; a plot of k_{obs} vs. σ_I shows considerable scatter. Interaction of the substituents with the carbon-carbon double bond undoubtedly varies greatly with the substituent. Two features of the Table are notable: (i) insertion of an α -methyl group [*cf.* substrates (28) and (29)] accelerates by a small factor; this is also found in styrenes [*cf.* substrates (1) and (3)]; (ii) the σ_I value of acetoxy (0.39) is substantially larger than that for ethoxycarbonyl (0.30) and yet the reactivity of vinyl acetate (30) is substantially larger than that of ethyl acrylate (28). This points to an additional stabilising effect of the acetoxy-group and interaction with the intermediate as in (53) may be involved.

Table 5 (continued)

Alkene	Adduct M ^a		Adduct M ^b		Found (%)			Calc. (%)	
	Yield (%)	Proton (δ)	Yield (%)	Proton (δ)	C	H	Formula	C	H
(19)	100	CHCl (3.9); CH ₂ SPh (3.0)	<i>f</i>		62.6	7.6	C ₁₂ H ₁₉ ClIS	63.0	7.5
(20)					44.8	4.3	C ₁₀ H ₁₂ BrClIS	44.6	4.3
(21)		CHCl (3.9); CH ₂ Cl (3.7); CH ₂ SPh (3.2)		CHSPh (3.4); CH ₂ Cl (3.75); CH ₂ Cl (3.75)	48.6	4.4	C ₈ H ₁₀ Cl ₂ S	48.8	4.6
(22)		m, 4.2—3.2		CHSPh (3.4); CH ₂ Cl (3.75); CH ₂ Br (3.75)	40.5	3.5	C ₈ H ₁₀ BrClIS	40.7	3.8
(23) ⁱ									
(24)	0		100	CHSPh (3.3); CH ₂ Cl (3.6); CH ₂ CN (2.7)	57.1	4.9	C ₁₀ H ₁₀ ClINS	56.8	4.8
(25)	0		100	CHSPh (3.8); CH ₂ Cl (3.7); ^m CH ₂ OPh (4.15)	64.5	5.6	C ₁₅ H ₁₅ ClOS	64.6	5.4
(26)		CHCl (4.1); CH ₂ SPh (3.1); CH ₂ Ph (3.2)		CHSPh (3.4); CH ₂ Cl (3.4); CH ₂ Ph (3.1)	68.9	5.7	C ₁₅ H ₁₅ ClIS	68.5	5.8
(27) ⁿ		Mixture (roughly 50 : 50) of aM and M adducts							
(28)		CHCl (4.0); CH ₂ SPh (3.3)		CHSPh; ^o CH ₂ Cl (3.6)	54.1	5.6	C ₁₁ H ₁₃ ClO ₂ S	53.9	5.4
(29)		CCH ₃ Cl (1.7); CH ₂ SPh (3.5)		CCH ₃ SPh (1.5); CH ₂ Cl (4.0)	54.1	5.4	C ₁₁ H ₁₃ ClO ₂ S	53.9	5.4
(30)	100	CHCl (6.4); CH ₂ SPh (3.3)							
(34)	100				61.9	6.3	C ₁₁ H ₁₃ ClIS	62.1	6.2
(35)	100	CHCl (4.85); CHSPh (4.0)			62.3	6.1	C ₁₁ H ₁₁ ClIS	62.1	6.2

^a Markownikoff. ^b anti-Markownikoff. ^c See text. ^d M.p. 71.4 °C. ^e M.p. 120.6 °C. ^f Orientation not meaningful. ^g M.p. 53.9 °C (B. B. Jarvis, W. P. Tong, and H. L. Ammon, *J. Org. Chem.*, 1975, **40**, 3189). ^h M.p. 90 °C. ⁱ Attached to ring. ^j Attached to side chain. ^k M.p. of double anti-Markownikoff product, 120.4 °C. ^l Products very unstable, structure not determined. ^m M.p. 70.5 °C. ⁿ Spectrum not well resolved; signal at τ 3.7 (1 H) disappears on D₂O shake; product too unstable for isolation. ^o Not definable.

Products.—Reactions were carried out under N₂ at -20 °C. The sulphenyl chloride (2—3 g) in the appropriate solvent (*ca.* 10 ml) was added to an equimolecular amount of alkene in the same solvent (*ca.* 20 ml) with stirring. After completion of the reaction the structure of the product was determined directly by studying the solution (for reactions in CCl₄) or after evaporation and redissolution of the residue in CCl₄. Details are in Table 5. Distillation of products was in most cases impossible because of decomposition. Additions to alkenes which did not give simple adducts are described below.

α -Methylstyrene (3).—The adduct was 95% (36) when the reaction was carried out at -20 °C. At 20 °C, (36) was accompanied by (37) and (38) and distillation of the product from reaction at -20 °C gave a mixture of (37) (65%) and (38) (35%).

1-Methylcyclohexene (11).—After 24 h the reaction mixture contained (¹H n.m.r.) (40) and (41) in the ratio 47 : 53. After 2 days at 30 °C the ratio was 85 : 15, and was unchanged after a further 3 days. Distillation gave (42) (38%), b.p. 147 °C at 0.07 mmHg, 95% pure by g.l.c.

4-Vinylcyclohexene (13).—With 2 mol of sulphenyl halide per mol of alkene, ¹H n.m.r. showed formation of a bis-adduct (no remaining olefinic protons) but the spectrum was too complex to allow assignment of the structure of the main product. With 1 mol of sulphenyl halide per mol of alkene, the ¹H n.m.r. spectrum showed about 70% of addition to the

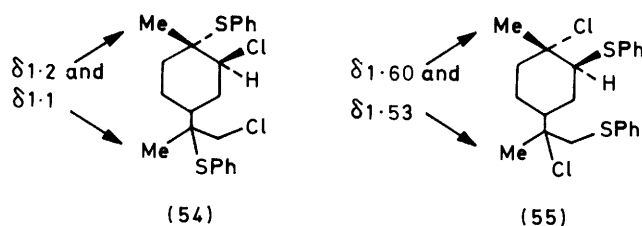

acyclic double bond. Again, assignment of orientation was not possible.

Limonene (14).—The ¹H n.m.r. of the total product mixture showed that the main adduct (66%) was (54) but exact ratios of isomers could not be determined. The residues from evaporation slowly crystallised to give (55) (27%), m.p. 120.4 °C (from light petroleum). When 1 mol of sulphenyl halide per mol of alkene was used, 70% of the addition occurred at the acyclic double bond.

4-Ethylidenenorbornene.—With equimolecular proportions of sulphenyl halide and alkene, reaction was very rapid and no olefinic proton signal was present in the ¹H n.m.r. spectrum. The quadruplet at δ 3.91 showed that chlorine was on a carbon adjacent to methyl and the signal for a proton on a carbon bearing the phenylthio group was a broad band at δ 3.2, *i.e.* at slightly lower field than for the simple norbornene adduct. Structure (44; R = Me) is therefore assigned.

Table 6. Kinetics of reactions of benzenesulphenyl chloride with cyclohexene in carbon tetrachloride at 25.4 °CPseudo-first-order conditions: [PhSCl] 4.17×10^{-3} mol dm⁻³; [cyclohexene] 6.24×10^{-2} mol dm⁻³

<i>t</i> /min	0	0.5	1.0	1.5	2.0	2.5
Absorbance at time <i>t</i>	1.416	1.090	0.840	0.640	0.498	0.385

<i>t</i> /min	3.0	3.5	4.5	
Absorbance at time <i>t</i>	0.307	0.250	0.200	$A_{\infty} = 0.055$

$$k 1.51 \times 10^{-1} \text{ dm}^3 \text{ mol}^{-1} \text{ s}^{-1}$$

Second-order-conditions: [PhSCl] 4.308×10^{-3} mol dm⁻³ [cyclohexene] 4.875×10^{-3} mol dm⁻³

<i>t</i> /min	0	5	10	15	20	25
Absorbance at time <i>t</i>	1.395	1.190	1.020	0.883	0.778	0.683

<i>t</i> /min	30	35	40
Absorbance at time <i>t</i>	0.610	0.545	0.490

$$k 1.71 \times 10^{-1} \text{ dm}^3 \text{ mol}^{-1} \text{ s}^{-1}$$

Table 7. Kinetics of reaction of benzenesulphenyl chloride with allyl alcohol at 25.4 °C

	$10^3[\text{PhSCl}]/$ mol dm ⁻³	$10^3[\text{allyl}$ alcohol]/mol dm ⁻³	$10 k^a$
In CCl ₄	3.22	34.1	1.73
	3.22	46.4	2.45
	3.22	55.7	3.09
	2.96	4.48	<i>b</i>
	2.96	5.89	<i>b</i>
In CH ₂ Cl ₂	3.45	3.85	<i>b</i>
	3.45	4.62	<i>b</i>
	3.45	3.46	<i>b</i>
In cyclohexane	3.19	38.0	1.01
	3.19	47.9	1.46
	3.19	64.0	1.89

^a Units: dm³ mol⁻¹ s⁻¹. ^b Second-order rate plots not rectilinear.**Table 8.** Kinetics of reactions of benzenesulphenyl chloride with hex-1-ene in the presence of propan-1-ol^a

$10 k^{b,c}$ [PrOH]/[hex-1-ene]	1.53 ^d	1.98	2.18	2.42
	0	10	20	30

^a Reactions in carbon tetrachloride; [PhSCl] 2.277×10^{-3} ; [hex-1-ene] 2.475×10^{-2} mol dm⁻³. ^b Units: dm³ mol⁻¹ s⁻¹. ^c At 31 °C. ^d Value at 25.4 °C, 0.99.

Kinetics.—Rates of reactions were followed spectroscopically at 388 nm using either a Unicam SP 800 or a Durrum-Gibson stopped-flow spectrometer. In the latter the photomultiplier output was digitised and fed into a Northern NS 600 Econ series multichannel analyser.

Reactions were followed for mixtures of alkene and sulphenyl halide in which either the concentrations were similar (in this case second-order rate constants were calculated directly from the rate of disappearance of sulphenyl halide), or substantial excesses (usually 10–20 mol excess of alkene), were employed. Sulphenyl halide concentrations were always between 2 and 5×10^{-3} mol dm⁻³, and the rate constants in Tables 2–4 are mean values obtained in a great majority of cases from three runs (if not, always from two). Reproducibility was within $\pm 3\%$, and in reactions run with an excess of

alkene the excess of alkene was varied between 10 and 30 mol excess without (except for the reactions with allyl alcohol) any significant variations in rate constant. Typical results are shown in Table 6 for the reaction of benzenesulphenyl chloride with cyclohexene under two different sets of conditions, and in Table 7 for reactions with allyl alcohol.

Acknowledgements

We thank the S.R.C. for equipment and studentship (to G. A. J.), I.C.I. Organics Division for the support of the investigation and the provision of certain alkenes, and Mr. G. Griffiths for determination of the results of Table 8.

References

- Part 36, R. J. Palmer and C. J. M. Stirling, *J. Am. Chem. Soc.*, 1980, **102**, 7888.
- For reviews see W. H. Mueller, *Angew. Chem. Int. Ed. Engl.*, 1969, **8**, 482; L. Rasteikiene, D. Greigiute, M. G. Linkova, and I. L. Knunyants, *Russ. Chem. Rev.*, 1977, **46**, 548.
- R. Bolton in 'Comprehensive Chemical Kinetics,' vol. 9, ed. C. H. Bamford and C. F. H. Tipper, Elsevier, London, 1973, p. 1.
- W. L. Orr and N. Kharasch, *J. Am. Chem. Soc.*, 1956, **78**, 1201.
- G. M. Beverly and D. R. Hogg, *J. Chem. Soc. B*, 1971, 175.
- H. Kwart and L. J. Miller, *J. Am. Chem. Soc.*, 1961, **83**, 4552.
- (a) G. H. Schmid and D. G. Garratt, *Can. J. Chem.*, 1974, **52**, 1807; (b) K. Izawa, T. Okuyama, and T. Fueno, *Bull. Chem. Soc. Jpn.*, 1974, **47**, 1480; (c) G. Collin, U. Jahnke, G. Just, G. Lorenz, W. Pritzkow, M. Rollig, and L. Winguth, *J. Prakt. Chem.*, 1969, **311**, 238.
- W. A. Thaler, *J. Org. Chem.*, 1969, **34**, 871.
- N. R. Slobodkin and N. Kharasch, *J. Am. Chem. Soc.*, 1960, **82**, 5837.
- G. H. Schmid, V. M. Csizmadia, V. J. Nowlan, and D. G. Garratt, *Can. J. Chem.*, 1972, **50**, 2457.
- G. H. Schmid and D. G. Garratt, *Can. J. Chem.*, 1973, **51**, 2463.
- C. L. Dean, D. G. Garratt, T. T. Tidwell, and G. H. Schmid, *J. Am. Chem. Soc.*, 1974, **96**, 4958.
- (a) M. J. Kamlet, J. L. M. Abboud, and R. W. Taft, *Prog. Phys. Org. Chem.*, 1981, **13**, 485; (b) G. H. Schmid, T. T. Tidwell, T. R. Cerskus, and V. M. Csizmadia, *Can. J. Chem.*, 1978, **56**, 205.
- D. R. Hogg and N. Kharasch, *J. Am. Chem. Soc.*, 1956, **78**, 2728.
- W. A. Thaler, W. H. Mueller, and P. E. Butler, *J. Am. Chem. Soc.*, 1968, **90**, 2069.
- W. H. Mueller and P. E. Butler, *J. Am. Chem. Soc.*, 1968, **90**, 2075, and references cited in ref. 15.
- G. H. Schmid and V. M. Csizmadia, *Can. J. Chem.*, 1966, **44**, 1338.
- G. H. Schmid and V. J. Nowlan, *J. Org. Chem.*, 1972, **37**, 3086.
- (a) W. A. Smit, N. S. Zefirov, I. V. Bodrikov, and M. Z. Krimer, *Acc. Chem. Res.*, 1979, **12**, 282; (b) V. M. Csizmadia, G. H. Schmid, P. G. Mezey, and I. G. Csizmadia, *J. Chem. Soc., Perkin Trans. 2*, 1979, 1019.
- M. Porter in 'Organic Chemistry of Sulphur,' ed. S. Oae, Plenum, New York, 1977.
- W. A. Thaler, *J. Org. Chem.*, 1969, **34**, 871.
- N. Kharasch and C. M. Buess, *J. Am. Chem. Soc.*, 1949, **71**, 2724.
- D. G. Garratt, P. L. Beaulieu, and V. M. Morisset, *Can. J. Chem.*, 1980, **58**, 1021.
- G. H. Schmid, *Can. J. Chem.*, 1968, **46**, 3757.
- J. G. Traynham, G. R. Franzen, G. A. Knesel, and D. J. Northington, *J. Org. Chem.*, 1967, **32**, 3285.
- A. Greenberg and J. F. Liebman, 'Strained Organic Molecules,' Academic Press, New York, 1978.
- J. B. Pedley and J. Rylance, Sussex-N.P.L. Computer-Analysed Thermochemical Data: Organic and Organometallic Compounds, University of Sussex, 1977.
- I. V. Bodrikov, T. S. Ganzhenko, F. M. Sokova, and N. S. Zefirov, *Zh. Org. Khim.*, 1980, **16**, 246.
- V. R. Kartashov, I. V. Bodrikov, E. V. Skorobogatova, and N. S. Zefirov, *Zh. Org. Khim.*, 1976, **12**, 297.

- 30 S. Braverman and Y. Stabinsky, *Chem. Commun.*, 1967, 270, and references there cited.
- 31 L. Rasteikiene, Z. Talaikyte, and V. Taliene, *Zh. Org. Khim.*, 1975, 11, 920.
- 32 W. H. Mueller and P. E. Butler, *Chem. Commun.*, 1966, 646; *J. Org. Chem.*, 1968, 33, 2642.
- 33 G. Kresze and W. Kosbahn, *Liebig's. Ann. Chem.*, 1970, 731, 67.
- 34 G. H. Schmid, S. Yeroushalmi, and D. G. Garratt, *J. Org. Chem.*, 1980, 45, 910.
- 35 F. R. Tantasheva, V. S. Savelev, E. A. Berdnikov, and E. G. Kataev, *Zh. Org. Khim.*, 1978, 14, 478.

Received 7th June 1982; Paper 2/942