

Highly Selective Cation Transport through Membranes containing Lipophilic Bis(monoaza-crown Ether)s

Hidefumi Sakamoto, Keiichi Kimura,* Yasuaki Koseki, and Toshiyuki Shono

Department of Applied Chemistry, Faculty of Engineering, Osaka University, Yamada-oka, Suita, Osaka 565, Japan

Ionophoric properties of lipophilic bis(monoaza-crown ether)s with 12-, 15-, and 18-membered rings, (1), (2), and (3) ($n = 1, 2, 3$), have been investigated in cation transport through supported liquid membranes. High ion selectivities were realized in facilitated cation transport through some membranes. Specifically, very high Na^+ selectivity with respect to other alkali metal ions was found for the (1) ($n = 1$) membrane system. There are large differences in the transportability and the ion selectivity among the three bis(monoaza-12-crown-4) or bis(monoaza-15-crown-5) derivatives, while the bis(monoaza-18-crown-6) derivatives show a general selectivity for K^+ . The transportabilities and ion selectivities may be controlled by changing the pH in the aqueous phases, thus taking advantage of protonation by the bridgehead nitrogens. Proton-driven selective cation transport through the bis(monoaza-crown ether) membranes, based on the protonation-deprotonation cycle, is also demonstrated.

Bis(crown ether)s, macrobicyclic polyethers containing two crown ether moieties at the end of a bridge chain, often undergo cation complexation by co-operative action of the two adjacent crown ether rings, which results in excellent ion selectivities as compared with those for their corresponding monocyclic analogues.¹⁻⁴ Expecting the so-called bis(crown ether) effect, various bis(crown ether) derivatives have been synthesized⁵⁻⁸ and applied as ionophores for cation membrane transport⁹ and ion-selective electrodes.¹⁰⁻¹⁶

Bis(monoaza-crown ether) derivatives, in which an oxygen atom in the crown ring is replaced by a nitrogen, are intriguing ionophores. Some bis(monoaza-crown ether)s can be obtained easily by linking two *N*-unsubstituted monoaza-crown rings

through the nitrogen atoms.^{17,18} We have also synthesized several lipophilic bis(monoaza-crown ether)s with 9-, 12-, 15-, and 18-membered rings and evaluated their cation-complexing abilities in a bulk phase.¹⁹ One of the differences between conventional bis(crown ether)s and bis(monoaza-crown ether)s is in protonation of the ring heteroatoms. The bridgehead nitrogens of bis(monoaza-crown ether)s are easily protonated under appropriate acidic conditions. Protonation depresses cation complexation of the crown ethers by electrostatic repulsion. Of course, bis(monoaza-crown ether)s, when deprotonated, are most likely to show such specific cation-complexing properties as observed in conventional bis(crown ether)s. Thus, bis(monoaza-crown ether)s are expected to

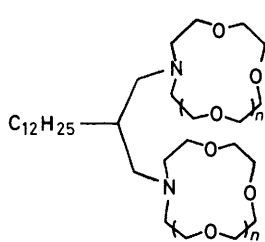

(1) ($n = 1, 2, 3$)

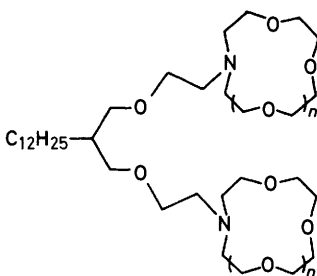

(2) ($n = 1, 2, 3$)

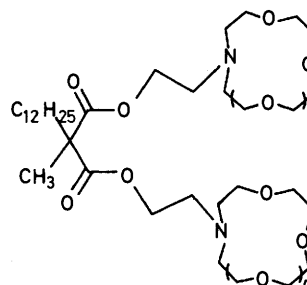

(3) ($n = 1, 2, 3$)

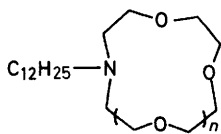

(4) ($n = 1, 2, 3$)

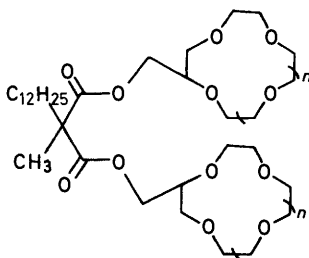

(5) ($n = 1, 2, 3$)

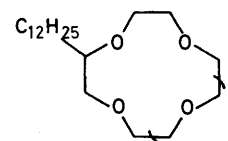

(6) ($n = 1, 2, 3$)

possess ion selectivities sensitive to pH and thereby controllable. This property is interesting especially in relation to cation transport through membranes containing the monoaza-crown ethers. Transport rates and ion selectivities through membranes may be regulated by the pH of the aqueous phases and highly selective proton-driven cation transport may be realized by using bis(monoaza-crown ether)s as ionophores. In a preliminary communication we outlined the excellent pH-sensitive cation selectivities of some bis(monoaza-crown ether)s in membrane cation transport.²⁰ We now report full details of the ionophoric properties of lipophilic bis(monoaza-crown ether)s (1)–(3) ($n = 1, 2, 3$) in the transport of alkali metal ions through membranes. The data are compared with the bis(crown ether)s (5) ($n = 1, 2, 3$) and corresponding monocyclic analogues (4) and (6) ($n = 1, 2, 3$).

Experimental

Materials.—The bis(crown ether) derivatives and the monocyclic analogues were synthesized according to procedures described elsewhere.^{15,19} Alkali metal chlorides were analytical grade. Picric acid was purified by recrystallization from ethanol. Microporous polypropylene film (maximum pore size of $0.04 \times 0.4 \mu\text{m}$, thickness of $25 \mu\text{m}$, Duragard 2500, Polyplastics Co. Ltd) was kindly given by the company. *o*-Nitrophenyl octyl ether (NPOE) was prepared by slight modification to a previously reported procedure.²¹ Water was deionized and distilled.

Membrane Cation Transport.—Competitive transport of alkali metal ions through membranes containing the crown ethers was conducted by using a glass cell as shown in Figure 1. The glass cell is divided into two compartments by a microporous polypropylene film impregnated with a crown ether NPOE solution. The impregnation was performed by soaking a film disk of 3 cm diameter into $8 \times 10^{-2} \text{ mol dm}^{-3}$ (for crown ring unit) crown ether NPOE solution. The external solution of the membrane was carefully wiped off with filter paper. The membrane, which contains about $10 \mu\text{l}$ of the crown ether solution, was then fixed to the glass cell by using silicone rubber packings and clips. The exposed area of the membrane was about 1 cm^2 . Equal volumes (20 ml) of appropriate aqueous solutions were placed simultaneously into the compartments to act as the source and receiving phases. The assembly was kept at 25°C during the transport experiment, by using a thermostatted bath. The aqueous phases were magnetically stirred at 400 r.p.m.

For the 'facilitated transport' studies the source and receiving phases are as follows. The source phase contained the alkali metal chlorides (Li^+ , Na^+ , K^+ , Rb^+ , and Cs^+) ($1 \times 10^{-2} \text{ mol}$

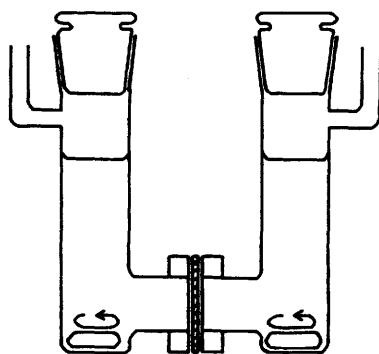

Figure 1. Glass cell apparatus employed for membrane cation-transport studies

dm^{-3} each). Picric acid ($5 \times 10^{-3} \text{ mol dm}^{-3}$) was dissolved in both the source and receiving phases. In the transport systems of (1)–(4), both of the aqueous phases were adjusted to pH 10 with 2-aminoethanol (0.1 mol dm^{-3})–HCl buffer unless otherwise stated. Other buffers were 2-amino-2-hydroxymethylpropane-1,3-diol–HCl for pH 8 and 9, and 3-(*N*-morpholino)propanesulphonic acid–tetramethylammonium hydroxide for pH 7. In the transport systems of (5) and (6) no buffer was employed. The concentrations of the metal salts and picric acid were the same as for the monoaza-crown ether systems, with the exception that picric acid was not added to the receiving phase.

In the 'proton-driven cation transport' studies using the bis(monoaza-crown ether)s, the alkali metal chlorides ($5 \times 10^{-3} \text{ mol dm}^{-3}$) and picric acid ($2.5 \times 10^{-3} \text{ mol dm}^{-3}$) were dissolved in both the source and receiving phases. The source (basic) and the receiving (acidic) phases contained tetramethylammonium hydroxide (0.1 mol dm^{-3}) and HCl (0.1 mol dm^{-3}), respectively.

The alkali metal ions in the aqueous phases were determined by flame photometry. Portions ($100 \mu\text{l}$) of the aqueous phases were occasionally extracted by microsyringe and 100-fold diluted solutions employed for ion determination.

Results and Discussion

Facilitated Cation Transport.—Facilitated transport of alkali metal ions, as their picrates, through membranes containing the crown ethers (1)–(6) was carried out, taking advantage of the cation concentration gradients between the source and receiving phases. Without picric acid, transport of the alkali metal ions through the membranes was negligible. Also, the NPOE-impregnated membrane not containing any of the crown ethers did not permit detectable cation transport. Competitive membrane transport of the five alkali metal ions was used to compare the cation transportabilities and selectivities of the crown ethers. The cation transportabilities of

Table. Transportabilities in membrane cation transport

Crown ether	Flux ^a ($10^{-7} \text{ mol m}^{-2} \text{ s}^{-1}$)				
	Li^+	Na^+	K^+	Rb^+	Cs^+
12-Membered rings					
(1) ($n = 1$)	0.4	31.4	1.4	1.0	0.4
(2) ($n = 1$)	3.6	7.5	38.0	17.0	7.2
(3) ($n = 1$)	4.9	6.8	6.1	3.6	2.9
(4) ($n = 1$)	4.8	5.6	2.7	1.8	1.5
(5) ($n = 1$)	0.8	26.2	2.6	2.6	0.8
(6) ($n = 1$)	<0.1	27.5	4.4	4.4	4.0
15-Membered rings					
(1) ($n = 2$)	0.1	0.9	22.3	14.6	1.4
(2) ($n = 2$)	4.0	28.8	22.6	16.4	16.0
(3) ($n = 2$)	1.9	27.1	17.4	15.6	9.0
(4) ($n = 2$)	4.8	57.2	21.0	14.8	8.1
(5) ($n = 2$)	1.2	3.8	13.4	10.4	3.9
(6) ($n = 2$)	<0.1	11.3	22.5	16.9	3.9
18-Membered rings					
(1) ($n = 3$)	<0.1	3.2	23.2	8.3	3.2
(2) ($n = 3$)	<0.1	6.0	44.0	15.8	6.1
(3) ($n = 3$)	0.2	1.8	38.8	16.6	5.7
(4) ($n = 3$)	1.8	8.7	51.4	22.1	10.8
(5) ($n = 3$)	<0.1	4.8	22.5	11.5	5.8
(6) ($n = 3$)	<0.1	4.1	30.6	19.4	10.9

^a Average fluxes up to 10 h calculated by the least-squares method.

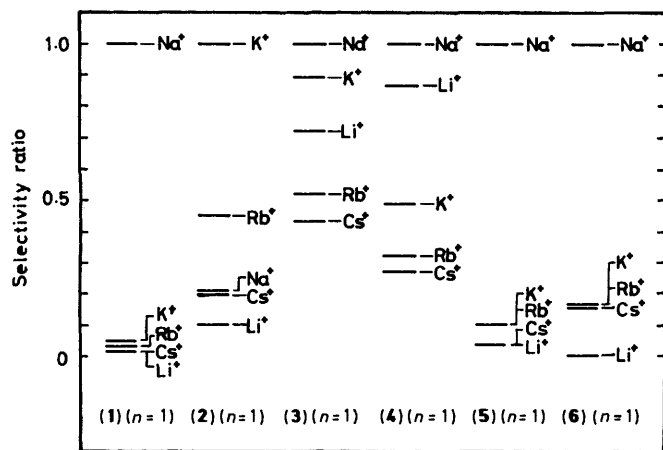

Figure 2. Selectivity ratios of the alkali metal ions over the most efficiently transferred ion in cation transport through membranes of 12-membered-ring crown ethers

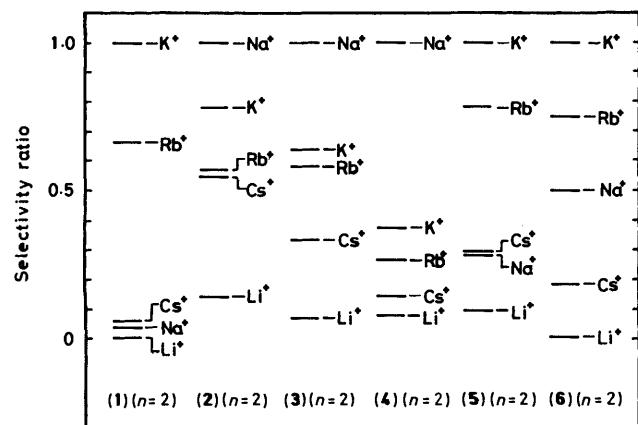

Figure 3. Selectivity ratios of the alkali metal ions over the most efficiently transferred ion in cation transport through membranes of 15-membered-ring crown ethers

(1)–(6) ($n = 1, 2, 3$) are listed as fluxes in the Table. The relative fluxes, normalised to the highest value, are expressed as selectivity ratios and are illustrated in Figures 2, 3, and 4.

The cation transport profile for the bis(monozaza-12-crown-4) derivative (1) ($n = 1$) is given in Figure 5 and illustrates that transport through the (1) ($n = 1$) membrane system is almost specific for Na^+ .

The high Na^+ selectivity of (1) ($n = 1$) with respect to K^+ is even more dramatic than expected from the stability constants of its cation complexes in a bulk phase [$\log K_s = 4.24$ for Na^+ and 2.37 for K^+ in $\text{MeOH-H}_2\text{O}$ (95:5)].¹⁹ In contrast the bis(monozaza-12-crown-4) derivative (3) ($n = 1$) and the monocyclic monozaza-12-crown-4 (4) ($n = 1$) are inefficient as ionophores, the ion selectivities being poor. The three bis(monozaza-12-crown-4) derivatives display considerable differences in their ionophoric properties. The bis(crown ether) effect is most evident for the (1) ($n = 1$) membrane system (see Figure 2). The high K^+ selectivity of (2) ($n = 1$) contrasts with the Na^+ selectivity of (1) ($n = 1$). This may support participation of the bridge chain ethereal oxygens in the K^+ complexation. Thus, the bis(crown ether) effect seems invalid in both the (2) and (3) ($n = 1$) membrane systems. The bis(12-crown-4) derivative (5) ($n = 1$) is a highly Na^+ selective

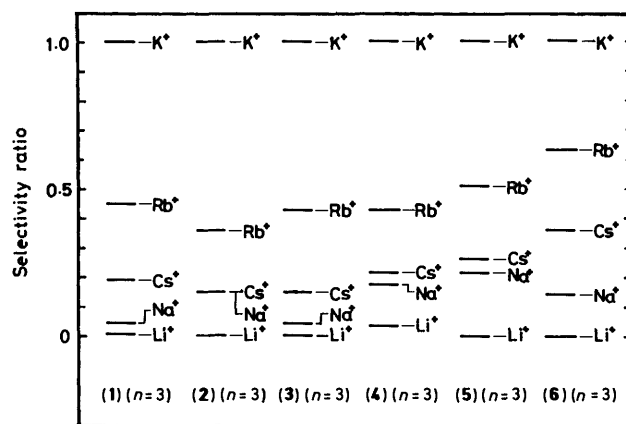

Figure 4. Selectivity ratios of the alkali metal ions over the most efficiently transferred ion in cation transport through membranes of 18-membered-ring crown ethers

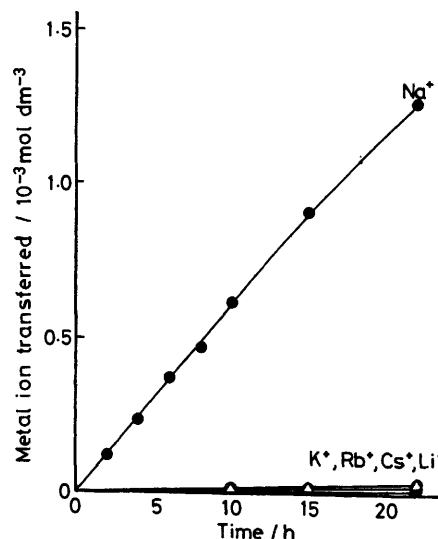

Figure 5. Competitive transport of alkali metal ions through the bis(monozaza-12-crown-4) (1) ($n = 1$) membrane system. Li^+ (\square), Na^+ (\bullet), K^+ (\circ), Rb^+ (\triangle), Cs^+ (\blacktriangle)

ionophore. However, (1) ($n = 1$) is still superior and is therefore promising for applications in analytical and separation chemistry. Surprisingly, the monocyclic 12-crown-4 derivative (6) ($n = 1$) showed comparable transport selectivity for the Na^+ ion [*cf.* (5) ($n = 1$)]. This may result from the formation of a 2:1 crown- Na^+ complex, which is more lipophilic and therefore more favourable than a 1:1 adduct in membrane cation transport.

Remarkable differences in transport selectivities were also found amongst the three bis(monozaza-15-crown-5) derivatives. For (1) ($n = 2$) cation transport is K^+ selective, the K^+/Na^+ selectivity ratio being very high. In contrast, (2) and (3) ($n = 2$) are Na^+ selective, as is the case for the monocyclic analogue (4) ($n = 2$). The reversal in the Na^+/K^+ selectivity can partly be explained by changes within the efficiency of the bis(crown ether) effect as mentioned for the bis(monozaza-12-crown-4) derivatives. The bis(15-crown-5) derivative, (5) ($n =$

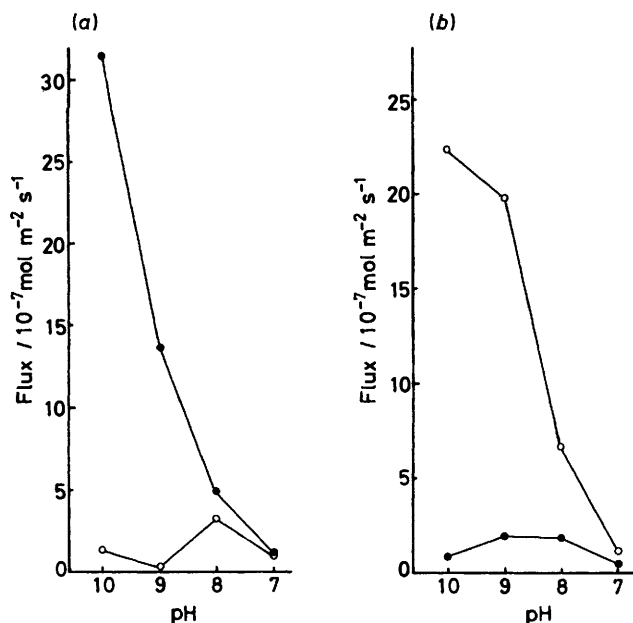

Figure 6. Effect of pH in the aqueous phases on the transportability of Na^+ and K^+ ions by bis(monooza-crown ether)s. (a) (1) ($n = 1$) system, (b) (1) ($n = 2$) system; Na^+ (●), K^+ (○)

2), exhibits a K^+ transport selectivity similar to that for the bis(monooza-crown ether) (1) ($n = 2$). The selectivity difference between (5) and (6) ($n = 2$) is not so remarkable as that between (1) and (4) ($n = 2$) which accompanies reversal in the Na^+/K^+ selectivity.

The 18-membered-ring crown ethers (1)–(6) ($n = 3$) are K^+ selective with selective cation transport decreasing in the order $\text{K}^+ > \text{Rb}^+ > \text{Cs}^+ > \text{Na}^+ > \text{Li}^+$. Contrary to the 12- and 15-membered-ring crown ethers there was no appreciable selectivity difference among the bis(monooza-crown ether)s and the monocyclic analogues. Moreover, the bis(monooza-18-crown-6) derivatives did not exhibit enhanced Cs^+ selectivity, which could be expected if the bis(crown ether) effect were valid in the cation complexation. Similarities in the cation complexation and the transportabilities of (1)–(4) ($n = 3$) imply that the ion selectivities of the bis(crown ether)s are attributed essentially to the 18-membered rings themselves. Accordingly, in the 18-membered crown ethers, pronounced improvement of the ion selectivity seems hard to attain by resorting to bis(crown ether) structures.

An interesting feature of the monoazacrown ethers is the ease of protonation at the ring nitrogen and thereby suppression of cation complexation. Complexing abilities of monoaza-crown ethers are, therefore, diminished at low pH values. The same is true for the bis(monooza-crown ether)s, except of course, that they experience a two-step protonation. Competitive transport of alkali metal ions through the (1) ($n = 1$)–NPOE membrane system was studied at various pH values, the pH of the source and receiving phases always being equal. The pH dependence of the transportability for Na^+ and K^+ in the membrane systems of (1) ($n = 1, 2$) are illustrated in Figure 6. As expected, marked diminution of the Na^+ flux was observed with decreasing pH of the aqueous phases in the (1) ($n = 1$) system with transportability being almost lost below pH 7. This applies equally to the K^+ flux in the (1) ($n = 2$) system. The Na^+/K^+ (or K^+/Na^+) selectivity ratios vary with the pH in both transport systems.

Two conclusions may be deduced from our results: (i) in

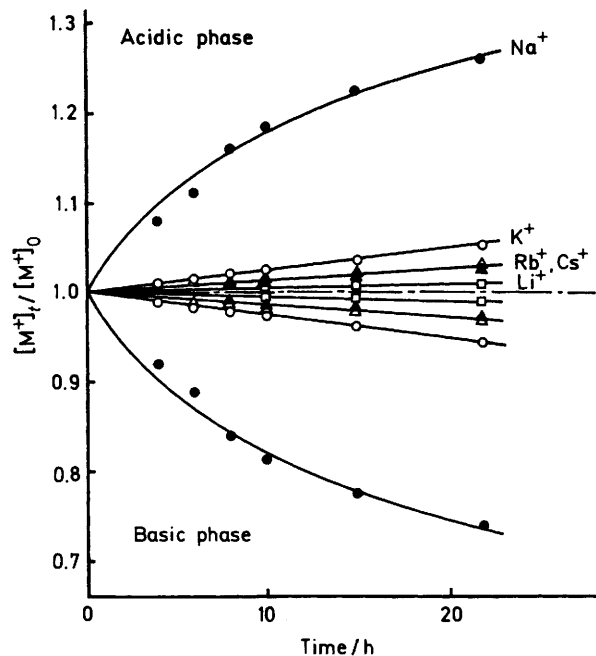

Figure 7. Proton-driven competitive transport of alkali metal ions through the (1) ($n = 1$) membrane system. The symbols are the same as for Figure 5. $[\text{M}^+]_t$ and $[\text{M}^+]_0$ stand for metal ion concentrations at time t and 0, respectively

the bis(monooza-crown ether) membrane system excellent Na^+/K^+ (or K^+/Na^+) selectivity is attainable only at high pH conditions of the aqueous phases, and (ii) the transportabilities and ion selectivities in membrane cation transport can be regulated by changing the pH. Thus, the bis(monooza-crown ether)s differ from bis(crown ether)s containing only oxygen atoms as the ring heteroatom, as in (5).

Proton-driven Cation Transport.—A further advantage for the bis(monooza-crown ether)s over the non-ionizable bis(crown ether)s is in their utilization for proton-driven membrane cation transport against cation concentration gradients. This phenomenon is based on the protonation–deprotonation cycle of monoaza-crown ethers in the membrane interface between acidic and basic aqueous phases.²² At the basic interface monoaza-crown ethers are deprotonated and are capable of forming ion-pair complexes with cations. These ion-pair complexes are transferred across the membrane to the acidic interface, where the crown ethers are protonated and concurrently release the cations to the acidic aqueous phase. Hence, pH gradients between the two aqueous phases permit membrane transport of certain cations against their concentration gradients.

A typical profile for the proton-driven cation transport by the bis(monooza-crown ether)s, showing the competitive transport of alkali metal ions (as their picrates) through the supported liquid membrane, is given in Figure 7 for (1) ($n = 1$). This clearly illustrates efficient up-hill cation transport, especially for the Na^+ . Excellent Na^+ selectivity of (1) ($n = 1$) was again realized in the proton-driven cation transport system. Similar up-hill cation transport was observed in the membrane systems of the other bis(monooza-crown ether)s, with ion selectivities reflected in those for the above-mentioned facilitated cation transport. Also, pH decreases in the basic phase brought about significant diminution in the transportability and ion selectivity.

References

- 1 M. Bourgoin, K. H. Wong, J. Y. Hui, and J. Smid, *J. Am. Chem. Soc.*, 1975, **97**, 3462.
- 2 K. Kimura, T. Maeda, and T. Shono, *Talanta*, 1979, **26**, 945.
- 3 K. Kimura, T. Tsuchida, T. Maeda, and T. Shono, *Talanta*, 1980, **27**, 801.
- 4 K. H. Wong and H. L. Ng, *J. Coord. Chem.*, 1981, **11**, 49.
- 5 F. Wada, R. Arata, T. Goto, K. Kikukawa, and T. Matsuda, *Bull. Chem. Soc. Jpn.*, 1980, **53**, 2061.
- 6 T. M. Handyside, J. C. Lockhart, M. B. McDonnell, and P. V. Subba Rao, *J. Chem. Soc., Dalton Trans.*, 1982, 2331.
- 7 B. Czech, A. Czech, S. I. Kang, and R. A. Bartsch, *Chem. Lett.*, 1984, 37.
- 8 H. Gruber and G. Schröder, *Liebigs Ann. Chem.*, 1985, 421.
- 9 A. H. Haines, I. Hodgkisson, and C. Smith, *J. Chem. Soc., Perkin Trans. 1*, 1983, 311.
- 10 T. Shono, M. Okahara, I. Ikeda, K. Kimura, and H. Tamura, *J. Electroanal. Chem. Interfacial Electrochem.*, 1982, **132**, 99.
- 11 K. Kimura, T. Maeda, H. Tamura, and T. Shono, *J. Electroanal. Chem. Interfacial Electrochem.*, 1979, **95**, 91.
- 12 K. Kimura, H. Tamura, and T. Shono, *J. Electroanal. Chem. Interfacial Electrochem.*, 1979, **105**, 335.
- 13 K. W. Fung and K. H. Wong, *J. Electroanal. Chem. Interfacial Electrochem.*, 1980, **111**, 359.
- 14 T. Ikeda, A. Abe, K. Kikukawa, and T. Matsuda, *Chem. Lett.*, 1983, 369.
- 15 K. Kimura, A. Ishikawa, H. Tamura, and T. Shono, *J. Chem. Soc., Perkin Trans. 2*, 1984, 447.
- 16 E. Lindner, K. Tóth, M. Horváth, E. Purgor, B. Ágai, I. Bitter, L. Töke, and Z. Hell, *Fresenius' Z. Anal. Chem.*, 1985, **322**, 157.
- 17 M. J. Calverley and J. Dale, *J. Chem. Soc., Chem. Commun.*, 1981, 684.
- 18 M. R. Johnson and I. O. Sutherland, *J. Chem. Soc., Chem. Commun.*, 1979, 306.
- 19 H. Sakamoto, K. Kimura, Y. Koseki, M. Matsuo, and T. Shono, *J. Org. Chem.*, 1986, **51**, 4974.
- 20 K. Kimura, H. Sakamoto, Y. Koseki, and T. Shono, *Chem. Lett.*, 1985, 1241.
- 21 C. F. H. Allen and J. W. Gates, 'Organic Syntheses,' Wiley; New York, 1955; Collect. vol. III. pp. 140—141.
- 22 K. Matsushima, H. Kobayashi, Y. Nakatsuji, and M. Okahara, *Chem. Lett.*, 1983, 701.

Received 11th June 1986; Paper 6/1168