

## The Mechanisms of the Rearrangements of Allylic Hydroperoxides: 5 $\alpha$ -Hydroperoxy-3 $\beta$ -hydroxycholest-6-ene and 7 $\alpha$ -Hydroperoxy-3 $\beta$ -hydroxycholest-5-ene

Athelstan L. J. Beckwith\*

Research School of Chemistry, Australian National University, Canberra A.C.T., 2601, Australia

Alwyn G. Davies,\* Ian G. E. Davison, Allan Maccoll, and Margaret H. Mruzek

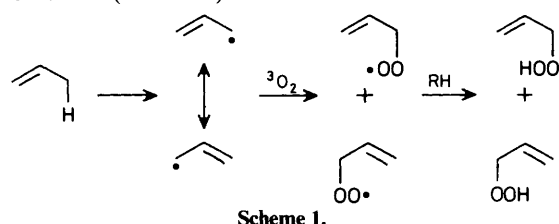
Chemistry Department, University College London, 20 Gordon Street, London WC1H 0AJ, U.K.

The rearrangement of 5 $\alpha$ -hydroperoxy-3 $\beta$ -hydroxycholest-6-ene in solution under  $^{18}\text{O}_2$ , gives isotopically normal 7 $\alpha$ -hydroperoxy-3 $\beta$ -hydroxycholest-5-ene, whereas the epimerization of this product to give 7 $\beta$ -hydroperoxy-3 $\beta$ -hydroxycholest-5-ene involves incorporation of 73–83% of  $^{18}\text{O}_2$  into the hydroperoxy group. These two reactions proceed through the corresponding hydroperoxyl radicals, which have different e.s.r. spectra and which therefore must exist as separate and distinct species.

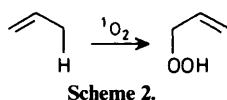
The former reaction shows a first-order dependence on hydroperoxide concentration, and a half-order dependence on t-butyl hyponitrite which was added as an initiator.

It is suggested that the first reaction involves a sigmatropic [2,3]-rearrangement, whereas the second reaction proceeds through a dissociative mechanism.

Allyl hydroperoxides are important and ubiquitous compounds which are formed when unsaturated compounds react with aerobic triplet oxygen (autoxidation). They are thus involved in processes such as the drying of paints, the development of rancidity in unsaturated fats, the perishing of rubber, or the disruption of cell membranes. Autoxidation is a radical-chain process, involving allyl and allylperoxyl radicals as the chain carriers, and usually results in the formation of a mixture of allylic isomers (Scheme 1).



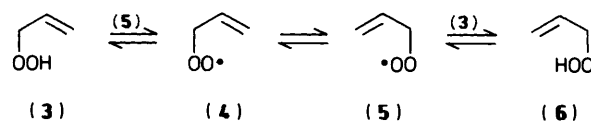
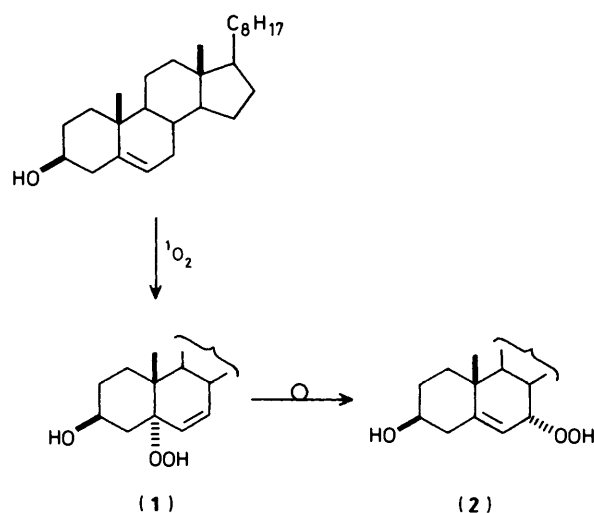
Allyl hydroperoxides are also formed when alkenes react with singlet oxygen. The reactions are usually carried out with photosensitization, and proceed with allylic isomerization by a concerted mechanism (Scheme 2).



In 1958, Schenck showed that 5 $\alpha$ -hydroperoxy-3 $\beta$ -hydroxycholest-6-ene (1) which is formed by the singlet  $\text{O}_2$  oxygenation of cholesterol, rearranges in non-polar solvents to 7 $\alpha$ -hydroperoxy-3 $\beta$ -hydroxycholest-5-ene (2).<sup>1–3</sup>

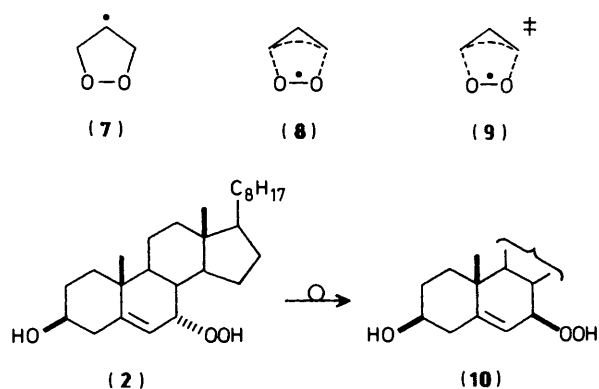
This rearrangement is presumably as ubiquitous as the allylic hydroperoxides themselves, but it is apparent only when the initial and final hydroperoxides are substitutionally non-equivalent, and when the initial hydroperoxide has a composition of allylic isomers which is different from that of the equilibrium mixture resulting from rearrangement.<sup>4</sup> As a consequence, despite the importance of this system, only some dozen examples of the rearrangement have been identified, half of which refer to cholestene derivatives.

Schenck showed that the rearrangement (1)  $\rightarrow$  (2) was catalysed by benzoyl peroxide or copper halides, or by



irradiation with light, and was inhibited by quinol, and concluded that the reaction proceeded through the intermediate allylperoxyl radicals represented by (4) and (5), and the 1,2-dioxolan-3-yl radical (7), and this model for the mechanism was initially supported by Brill.<sup>5</sup>

Subsequently however, Brill<sup>6</sup> and Porter,<sup>7</sup> provided evidence against a carbon-centred radical intermediate because it could not be caused to undergo ring-opening  $\beta$ -scission when the radical centre was next to a small strained ring, and it could not be trapped by oxygen to give a hydroperoxy peroxide. Brill suggested<sup>6</sup> that the open allylperoxyl radicals (4) and (5) did not exist, but that loss of hydrogen atom from the hydroperoxyl group in (3) or (6) led straight to a common cyclic intermediate (8) in which the unpaired electron was localized in an antibonding  $\pi$ -orbital on oxygen.



Scheme 5.

Very recently, Porter has shown<sup>8</sup> that when the  $\Delta^8$ -10-hydroperoxide and the  $\Delta^{10}$ -9-hydroperoxide obtained from the autoxidation of oleic acid were allowed to interconvert under an atmosphere of  $^{18}\text{O}_2$ , the oxygen was not incorporated into the hydroperoxide, and they proposed that the rearrangement involved the cyclic transition state (9).

In 1973, Smith<sup>9</sup> identified a further rearrangement undergone by allylic hydroperoxides:  $7\alpha$ -hydroperoxy- $3\beta$ -hydroxycholest-5-ene in ethyl acetate at  $40^\circ\text{C}$  underwent 25–30% epimerization in 48 h to the  $7\beta$ -hydroperoxide (10) (Scheme 5). We can find no further clear example of this type of reaction in the literature, nor any comment on its mechanism.

We report here a study of the mechanisms of Schenck's rearrangement of  $5\alpha$ -hydroperoxy- $3\beta$ -hydroxycholest-6-ene, and of Smith's rearrangement of  $7\alpha$ -hydroperoxy- $3\beta$ -hydroxycholest-5-ene. This system has the advantages that the hydroperoxyl groups are located at chiral centres, that the rearrangements (1)  $\rightarrow$  (2) and (2)  $\rightarrow$  (10) are unidirectional, and that the various isomers can be distinguished by  $^1\text{H}$  n.m.r. spectroscopy.

## Results

$5\alpha$ -Hydroperoxy- $3\beta$ -hydroxycholest-6-ene (1) was prepared by photosensitized oxygenation of cholesterol,<sup>1</sup> and allowed to arrange in chloroform solution to  $7\alpha$ -hydroperoxy- $3\beta$ -hydroxycholest-5-ene (2). Figure 1 shows the  $^1\text{H}$  n.m.r. spectra, expanded in the regions of the  $\text{C}=\text{CH}$ ,  $\text{CH}=\text{CH}$ ,  $\text{CHOH}$ , and  $\text{CHOOH}$  signals, of recrystallized (1), and of (2) which had been purified by preparative h.p.l.c.

The hydroperoxides were dissolved in chloroform and photolysed at 223 K in the cavity of an e.s.r. spectrometer, when the spectra of the corresponding  $\Delta^6$ - $5\alpha$ -peroxyl radical (11) and  $\Delta^5$ - $7\alpha$ -peroxyl radical (12) were observed as a singlet,  $g$  2.0151, and a doublet,  $a(1\text{H})$  2.73 G,  $g$  2.0145, respectively (Scheme 6 and Figure 2).

A solution of  $3\beta$ -benzoyloxy- $7\alpha$ -bromocholest-5-ene and hexabutyldistannane in toluene was photolysed at 191 K in the cavity of an e.s.r. spectrometer, when it showed the spectrum of the corresponding cholest-5-en-7-yl radical,  $a(2\text{H})$  25.0,  $a(1\text{H})$  12.7,  $\Delta H_{\text{pp}}$  7 G,  $g$  2.0025. When oxygen was admitted to the tube, this spectrum was replaced by that of overlapping broad signals of peroxy radicals,  $g$  2.065 and 2.015, in which no proton hyperfine coupling could be detected.

A solution of the  $\Delta^6$ - $5\alpha$ -hydroperoxide (1) in chloroform was stirred under 99.5%  $^{18}\text{O}_2$  for 3.5 h so that rearrangement was incomplete, then the mixed hydroperoxides (1), (2), and (10) were reduced with triphenylphosphine (Scheme 6). The diols (13), (14), and (15) which were formed were separated by preparative h.p.l.c., and identified by  $^1\text{H}$  n.m.r. spectroscopy (Figure 3), and analysed isotopically by mass spectroscopy

Table 1. Effect of additives on the rearrangements (1)  $\rightarrow$  (2)  $\rightarrow$  (10).<sup>a</sup>

| Additive (mol%) | <i>t</i> /h | Composition (mol%) |     |      |      |
|-----------------|-------------|--------------------|-----|------|------|
|                 |             | (1)                | (2) | (10) | (22) |
| Blank           | 48          | <i>c</i>           | 80  | 20   | 0    |
| (16) (10)       | —           | <i>c</i>           | 100 | 0    | 0    |
| Blank           | 144         | 0                  | 84  | 11   | 5    |
| (17) (10)       | —           | 0                  | 84  | 10   | 6    |
| (17) (10)       | 24          | 54                 | 46  | 0    | 0    |
| (18) (10)       | 24          | 77                 | 23  | 0    | 0    |
| (19) (10)       | 24          | 77                 | 23  | 0    | 0    |
| Blank           | 48          | 0                  | 89  | 11   | 0    |
| (20) (5)        | —           | 89                 | 10  | 1    | 0    |
| (21) (33)       | 43.5        | 62                 | 38  | 0    | 0    |
|                 | 72.5        | 41                 | 57  | 0    | 2    |

<sup>a</sup> The reaction involving (16) was carried out in EtOAc at  $40^\circ\text{C}$ . All the other reactions were carried out in  $\text{CDCl}_3$ . <sup>b</sup>  $3\beta$ -Hydroxycholest-5-en-7-one. <sup>c</sup> The reactant was the  $7\alpha$ -hydroperoxide (2); all the other reactions were carried out with the  $5\alpha$ -hydroperoxide (1).

(Figure 4). In duplicate experiments, the  $^{18}\text{O}$  content of (13), (14), and (15) was found to be 0, 0, and 82%, and 0, 0, and 83%, respectively. The presence of  $^{18}\text{O}$  was confirmed in the triphenylphosphine oxide (9.5 and 9.4%, respectively).

The pure  $\Delta^5$ - $7\alpha$ -hydroperoxide (2) was similarly allowed to rearrange in chloroform under  $^{18}\text{O}_2$  for 3.5 h, and the mixed hydroperoxides (2) and (10) were reduced with triphenylphosphine, and the diols (14) and (15) were separated by preparative h.p.l.c. The diol (14) was isotopically normal, but (15) contained 73%  $^{18}\text{O}$ , and the phosphine oxide contained 3.3%  $^{18}\text{O}$ .

The effect of the additives (16)–(21) on the rearrangements (1)  $\rightarrow$  (2), and (2)  $\rightarrow$  (10) was determined by monitoring by  $^1\text{H}$  n.m.r. spectroscopy ( $\delta$  3.5–5.9) the decrease in concentration of (1) or (2) and the formation of (2) and/or (10) or the formation of the enone (22) (Table 1).

2,6-Di-*t*-butyl-4-methylphenol (16) was found to inhibit the epimerization (2)  $\rightarrow$  (10), as it does the rearrangement (1)  $\rightarrow$  (2). The isoindole-based nitroxyl radical (17) had no significant effect on either reaction, but the piperidine-based nitroxyls (18) and (19) inhibited both rearrangements. EDTA (20) similarly inhibited the rearrangement (1)  $\rightarrow$  (2). DABCO (1,4-diazabicyclo[2.2.2]octane) (21) was a weaker inhibitor, and over 72.5 h induced the formation of some of the enone (22).

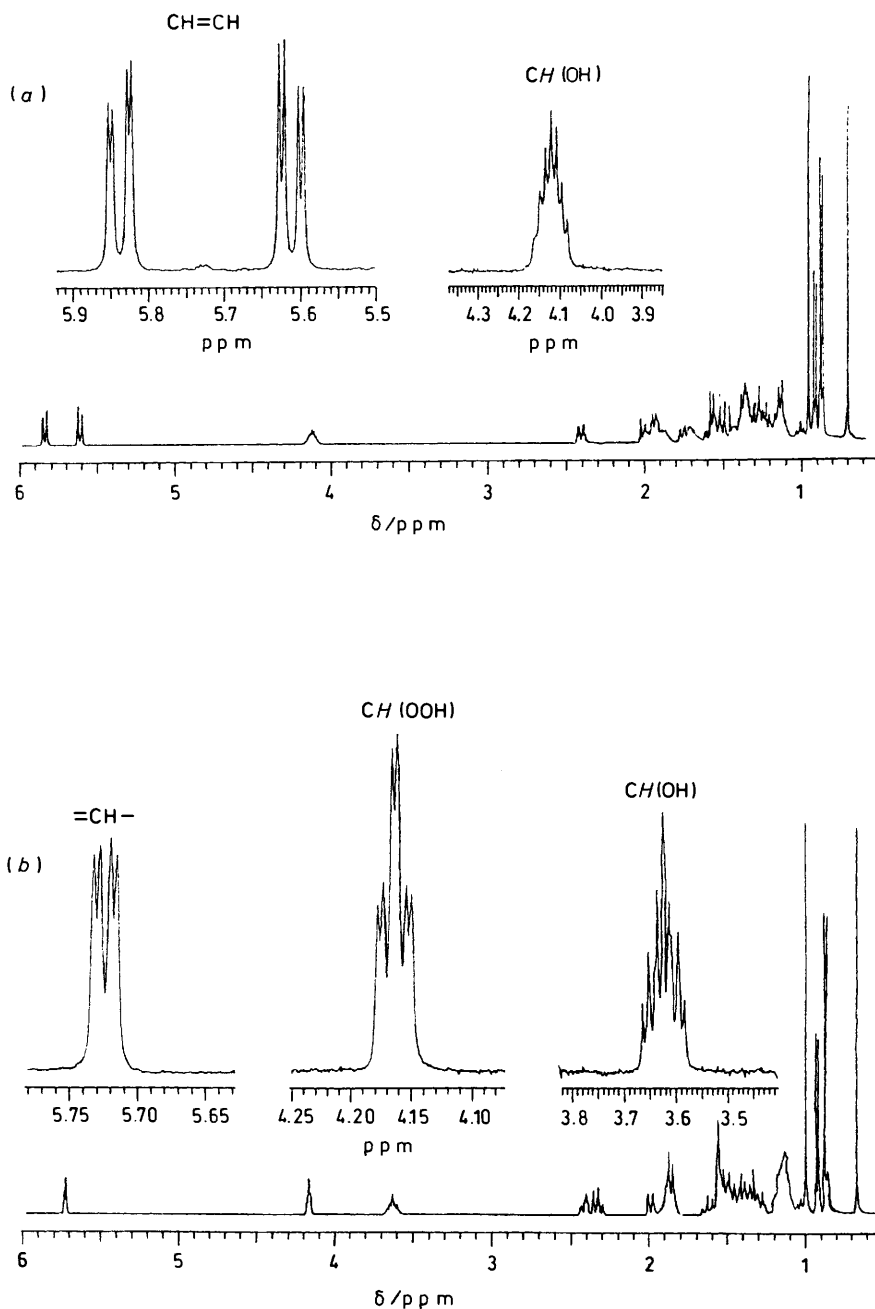
The effect of the partial pressure of oxygen on both the rearrangements (1)  $\rightarrow$  (2) and (2)  $\rightarrow$  (10) was determined by monitoring the  $^1\text{H}$  n.m.r. spectrum under argon and under air, using di-*t*-butyl hyponitrite as an initiator. Under the two conditions, both rearrangements proceed to the same extent, irrespective of the partial pressure of oxygen, and give a mixture consisting of 18% of the  $7\alpha$ -hydroperoxide (2), and 15% of the  $7\beta$ -hydroperoxide (10) and none of the starting material (1).

The kinetics of the rearrangement (1)  $\rightarrow$  (2) were followed by monitoring by 400 MHz  $^1\text{H}$  n.m.r. spectroscopy of the alkenic region of the spectra [Figures 1(a) and 1(b)]. Reactions were carried out in  $\text{CDCl}_3$  at  $20^\circ\text{C}$  in the absence of an initiator, or at  $30^\circ\text{C}$  in  $\text{CDCl}_3$  or  $\text{C}_6\text{D}_6$ , with di-*t*-butyl hyponitrite (TBHN) as an initiator.

G.l.c. analysis of the solution showed the formation, in  $\text{CDCl}_3$ , of a trace of hexachloroethane in the absence or presence of the initiator. However, good first-order kinetics were observed in both solvents, as illustrated in Figure 5.

The results are summarized in Table 2, where the overall rate of reaction is given by  $k[(1)]$ .

In order to check whether hydrogen bonding might



**Figure 1.**  $^1\text{H}$  N.m.r. spectra (400 MHz;  $\text{CDCl}_3$ ) of (a)  $5\alpha$ -hydroperoxy- $3\beta$ -hydroxycholest-6-ene (1) and (b)  $7\alpha$ -hydroperoxy- $3\beta$ -hydroxycholest-5-ene (2).

complicate the kinetics, the infrared spectra of cholesterol and of the  $5\alpha$ -hydroperoxide (1) were recorded as KBr discs, and in  $\text{CDCl}_3$  at the same concentration as in the kinetics experiments. In KBr, cholesterol showed  $\nu_{\text{max}}$   $3\,416\text{ cm}^{-1}$  (OH str.), and the  $5\alpha$ -hydroperoxide (1) showed  $\nu_{\text{max}}$   $3\,422$  (OH str.) and  $3\,217\text{ cm}^{-1}$  (OO-H str.). In  $\text{CDCl}_3$ , cholesterol showed  $\nu_{\text{max}}$   $3\,606\text{ cm}^{-1}$  (OH str.); and (1) showed  $3\,606$  (OH str.) and  $3\,514\text{ cm}^{-1}$  (OO-H str.).

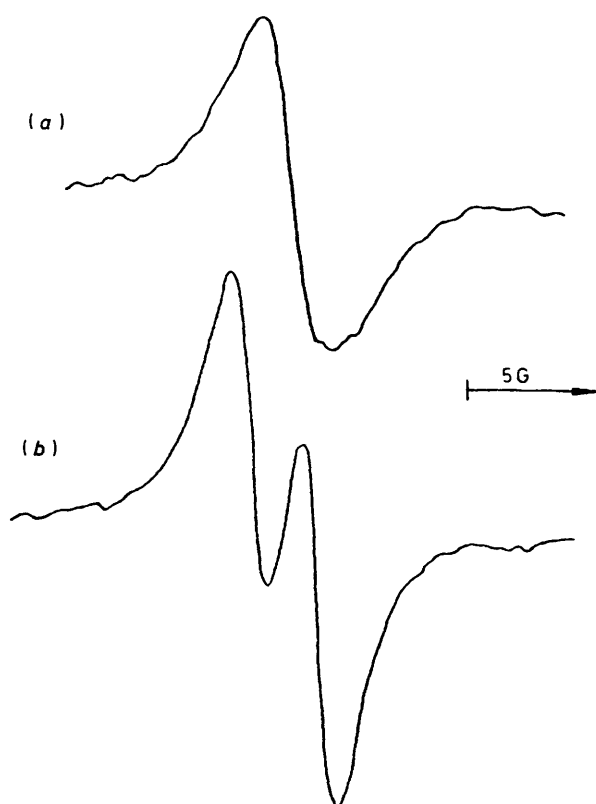
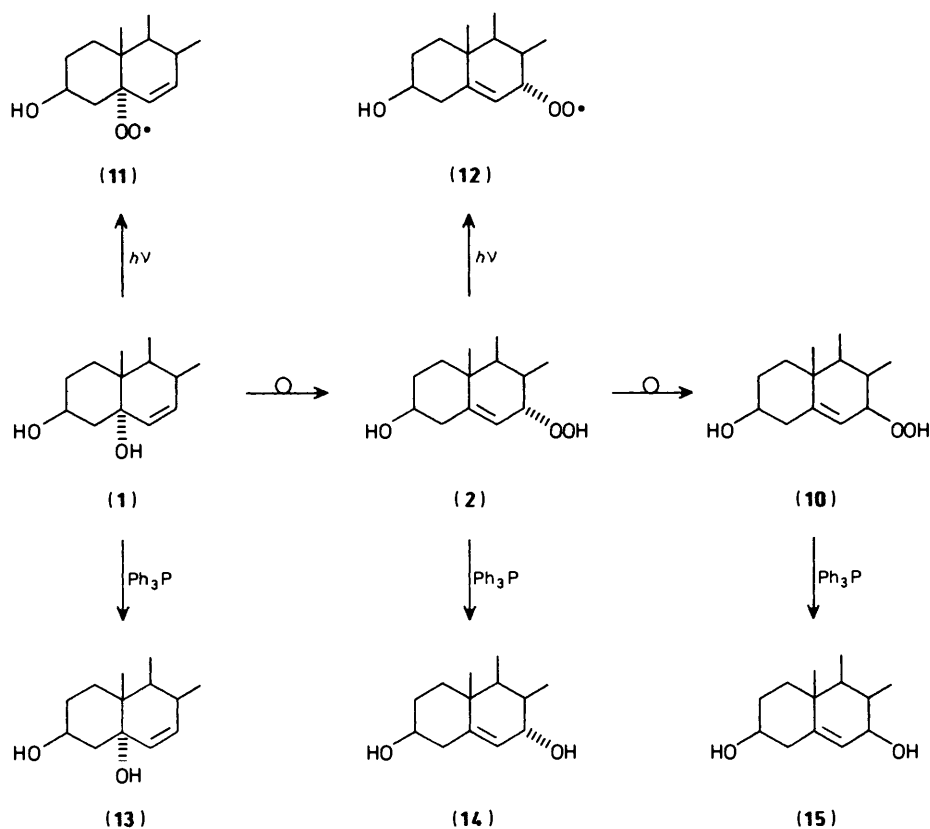
Experiments were also carried out on the photosensitized oxygenation of some 3-*O*-derivatives of cholesterol. Under the same conditions under which cholesterol gave the  $5\alpha$ -hydroperoxide (5), the 3-*O*-acetyl derivative gave principally the  $7\alpha$ -hydroperoxide, though in the presence of 2,6-di-*t*-butyl-4-methylphenol (16), a substantial amount of the  $5\alpha$ -hydroperoxide could be detected by n.m.r. spectroscopy. Similarly the 3-

*O*-methyl and 3-*O*-trimethylsilyl derivatives gave principally the corresponding  $7\alpha$ - rather than the  $5\alpha$ -hydroperoxide.

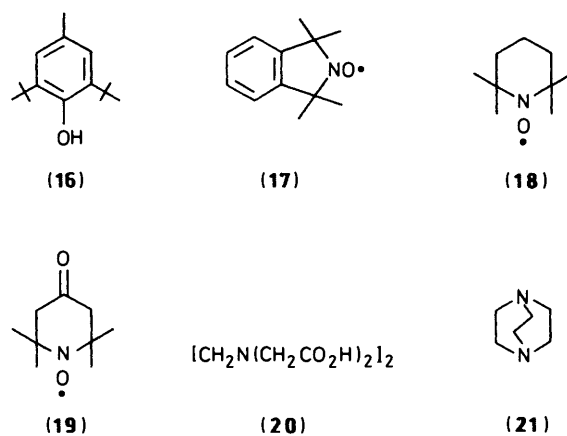
### Discussion

**E.S.R. Spectra.**—Photolysis of the hydroperoxides (1) and (2) would be expected to cleave the peroxide bond to give alkoxy and hydroxyl radicals, which would then abstract hydrogen from the parent hydroperoxide to give the corresponding alkylperoxy radicals (11) and (12) respectively. The high *g* values and large line widths for the e.s.r. spectra which are observed (Figure 2) are typical of alkylperoxy radicals, and the small doublet hyperfine coupling of 2.73 G is characteristic of a secondary alkylperoxy radical.

This establishes that the allylperoxy radicals (11) and (12)

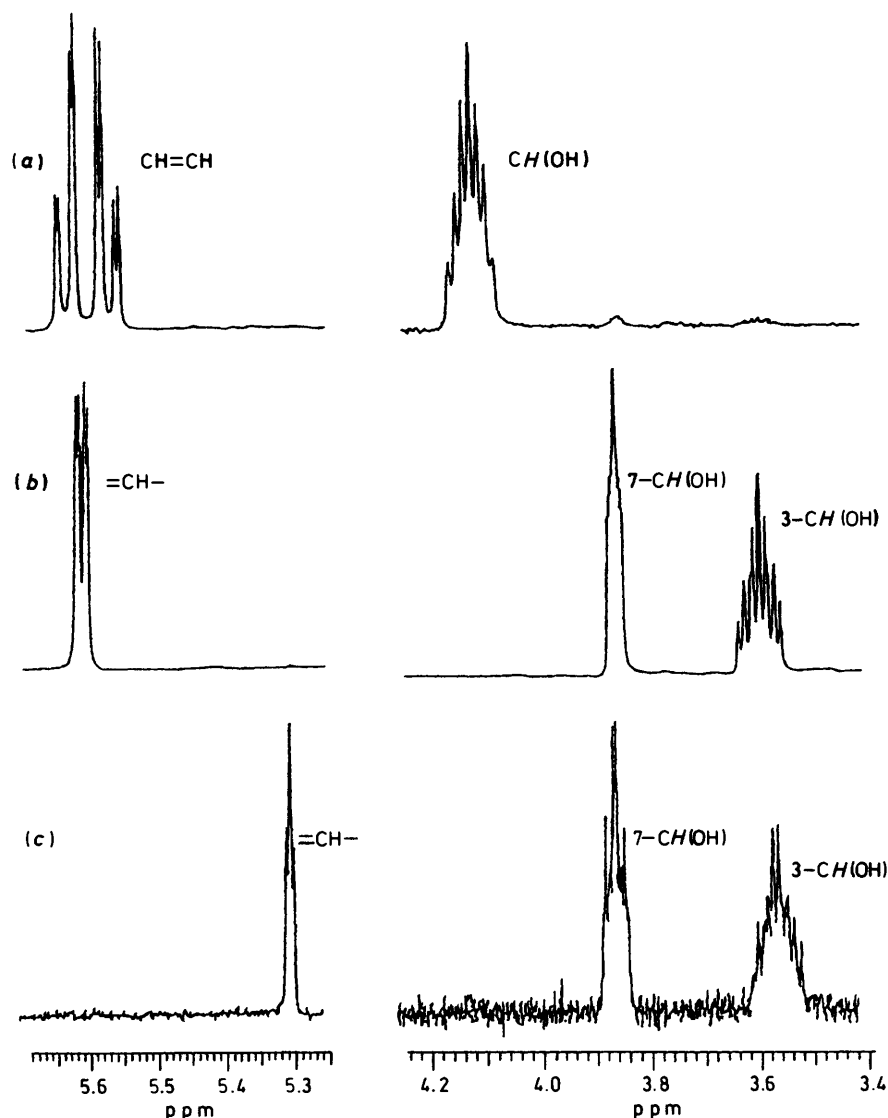


**Figure 2.** E.s.r. spectra in  $\text{CHCl}_3$  at 220 K of (a) the  $3\beta$ -hydroxycholest-6-ene-5 $\alpha$ -peroxyl radical (11) and (b) the  $3\beta$ -hydroxycholest-5-ene-7 $\alpha$ -peroxyl radical (12).



are separate and distinct species, and that they do not have the common cyclic structure (8). Similar evidence is provided by the singlet and doublet spectra of the peroxy radicals obtained from the corresponding ethyloctalin hydroperoxides,<sup>10</sup> and from other examples in the literature. For example, the spectrum of the cyclohex-2-en-ylperoxy radical shows doublet coupling,  $a(1\text{ H})\ 5\text{ G}$ ,<sup>11</sup> rather than the triplet coupling which would be expected from two equivalent hydrogen atoms in a cyclic structure.

The e.s.r. spectrum of the radical which is obtained by the abstraction of bromine from 7 $\alpha$ -bromocholesteryl benzoate is appropriate for the allyl radical (23;  $\text{R} = \text{PhCO}$ ) (Scheme 7). The hyperfine coupling of 12.7 G is typical for a proton at the terminus of an allyl system, and may be assigned to 7-H, and the large couplings at 25.0 G may be assigned to the axial protons at C-4 and C-8. The relatively small coupling to the equatorial



**Figure 3.** Partial  $^1\text{H}$  n.m.r. spectra (400 MHz;  $\text{CDCl}_3$ ) of (a)  $3\beta,5\alpha$ -dihydroxycholest-6-ene (**13**), (b)  $3\beta,7\alpha$ -dihydroxycholest-5-ene (**14**), and (c)  $3\beta,7\beta$ -dihydroxycholest-5-ene (**15**).

**Table 2.** Kinetics of the rearrangement (1)  $\rightarrow$  (2).

| Solvent                    | $[1]_0/10^{-3} \text{ mol dm}^{-3}$ | $[\text{TBHN}]_0/10^{-3} \text{ mol dm}^{-3}$ | $[\text{TBHN}]_{av}/10^{-3} \text{ mol dm}^{-3}$ | $[\text{TBHN}]_{av}^\dagger/10^{-2} \text{ mol}^\ddagger \text{ dm}^{-3}$ | $k_{\text{obs}}/10^{-4} \text{ s}^{-1}$ | $(k_{\text{obs}}/[\text{TBHN}]_{av}^\dagger)/10^{-3} \text{ dm}^\ddagger \text{ mol}^\ddagger \text{ s}^{-1}$ | $k_p/10^3 \text{ dm}^3 \text{ mol}^{-1} \text{ s}^{-1}$ |
|----------------------------|-------------------------------------|---|--|---|---|---|---|
| (a) $\text{CDCl}_3^a$      | 15.95                               | 0   | 0  | 0   | $0.28 \pm 0.01$                         | —   | —   |
| $\text{CDCl}_3$            | 15.09                               | 16.09   | 15.95  | 12.63   | $3.51 \pm 0.06$                         | 2.78  | 2.91  |
| $\text{CDCl}_3$            | 15.95                               | 4.90  | 4.81   | 6.94  | $2.02 \pm 0.03$                         | 2.90  | 3.05  |
| $\text{CDCl}_3$            | 12.50                               | 4.83  | 4.74   | 6.89  | $1.77 \pm 0.02$                         | 2.56  | 2.69  |
| $\text{CDCl}_3$            | 15.28                               | 4.83  | 4.75   | 6.89  | $1.93 \pm 0.02$                         | 2.80  | 2.93  |
| $\text{CDCl}_3$            | 10.84                               | 10.92   | 10.81  | 10.40   | $2.60 \pm 0.05$                         | 2.50  | 2.62  |
| (b) $\text{CDCl}_3$        | 12.91                               | 2.09  | 2.06   | 4.54  | $1.24 \pm 0.01$                         | 2.73  | 2.72  |
| $\text{C}_6\text{D}_6$     | 6.91                                | 1.03  | 1.02   | 3.19  | $1.31 \pm 0.04$                         | 4.12  | 4.31  |
| $\text{C}_6\text{D}_6$     | 6.42                                | 1.24  | 1.23   | 3.51  | $1.13 \pm 0.05$                         | 3.23  | 3.38  |
| $\text{C}_6\text{D}_6$     | 6.88                                | 0.81  | 0.79   | 2.81  | $1.03 \pm 0.05$                         | 3.67  | 3.84  |
| (c) $\text{C}_6\text{D}_6$ | 6.55                                | 0.76  | 0.74   | 2.72  | $0.92 \pm 0.02$                         | 3.38  | 3.54  |

<sup>a</sup> At 20 °C. All the other experiments were carried out at 30 °C.

proton at C-4, and the proton at the nodal plane of the  $\pi$ -system at C-6 would be lost in the line width.

A less well resolved spectrum of the allylic radical derived from the  $\gamma$ -radiolysis of cholesterol itself has been reported previously.<sup>12</sup>

The autoxidation of cholesterol has been reported to lead to 7-oxygenated products through formation of the 7-hydroperoxide.<sup>13</sup> Similarly the homolytic bromination of cholesteryl benzoate gives the  $7\alpha$ -bromo derivative.<sup>14</sup> The reason why the allylic radical should apparently react preferentially at the 7-

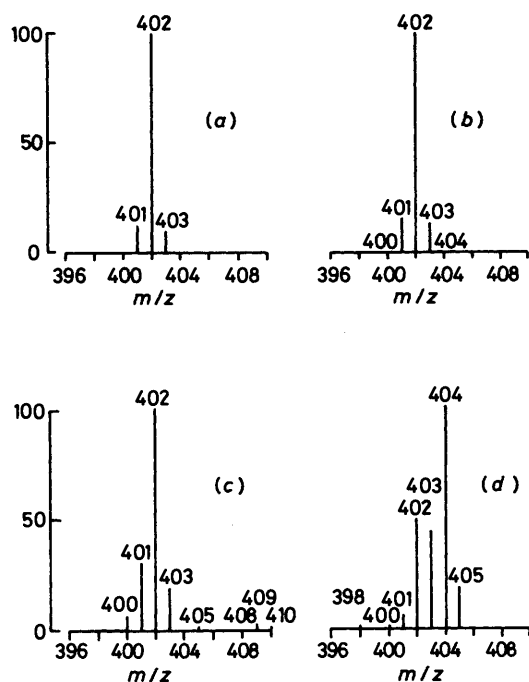
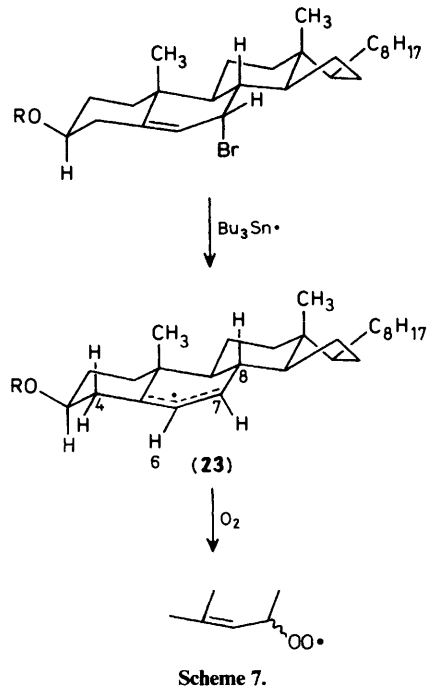


Figure 4. Mass spectra of 3,5-diols (e.i.; 18 eV): (a) (14) from the rearrangement of (1) under  $^{16}\text{O}_2$ , (b) (14) from the rearrangement of (1) under  $^{18}\text{O}_2$ , (c) (15) from the rearrangement of (2) under  $^{16}\text{O}_2$ , and (d) (15) from the rearrangement of (2) under  $^{18}\text{O}_2$ .



rather than 5-position is not obvious, but it does correlate with the fact that the rearrangement of the  $5\alpha$ - to the  $7\alpha$ -hydroperoxide is not reversible.

We hoped that e.s.r. spectroscopy would confirm that the radical (23) did indeed react with oxygen at the 7-position to show the doublet spectrum of the 7-peroxy radical rather than the singlet of the 5-peroxy radical (*cf.* Figure 1), but the line width, resulting probably from the presence of paramagnetic triplet oxygen, prevented the distinction being made. The line at

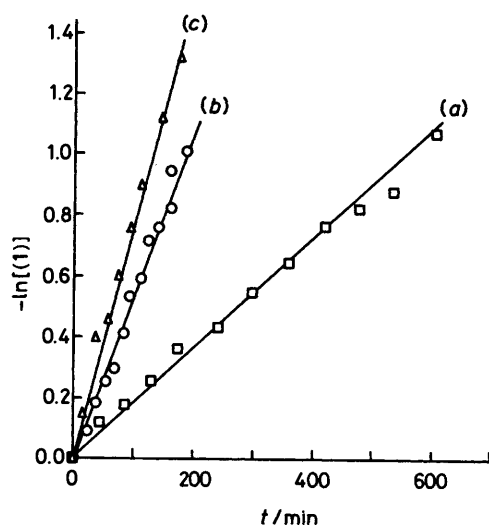


Figure 5. Kinetics of the rearrangement (1)  $\rightarrow$  (2): (a) in  $\text{CDCl}_3$  at  $20^\circ\text{C}$ , (b) in  $\text{CDCl}_3$  containing TBHN ( $2.09 \text{ mol dm}^{-3}$ ) at  $30^\circ\text{C}$ , (c) in  $\text{C}_6\text{D}_6$  containing TBHN ( $0.76 \text{ mol dm}^{-3}$ ) at  $30^\circ\text{C}$ . Details are given in Table 2.

2.015 presumably relates to the allylperoxy radical, and that at 2.065 to the radical  $\text{Bu}_3\text{SnOO}\cdot$ .<sup>15</sup>

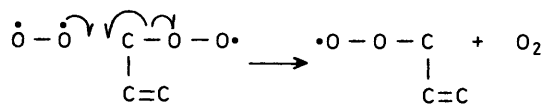
*The  $5\alpha$ -  $\rightarrow$   $7\alpha$ -Hydroperoxide Rearrangement.*—The rearrangement of (1) appears to be wholly suprafacial and irreversible, the  $7\beta$ -hydroperoxide (10) being formed only by the subsequent epimerization of the  $7\alpha$ -hydroperoxide (2).

The shift involves no incorporation of oxygen from an  $^{18}\text{O}_2$  atmosphere, and the allyl and  $\text{O}_2$  moieties therefore cannot exist as kinetically free entities. The effect of nitroxyl-radical traps on the rearrangement was not definitive, and is discussed below.

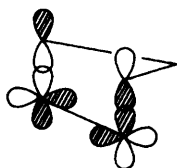
The most probable mechanism compatible with this evidence appears to be a pericyclic process similar to that preferred by Porter and Wujek for the rearrangement of the hydroperoxides derived from oleic acid.<sup>8</sup> The symmetry-allowed interaction of the allyl and  $^3\text{O}_2$  HOMOs is illustrated in (24), where the electron is located in an antibonding orbital on oxygen. This is similar to the description which Brill gave for his proposed cyclic allylperoxy radical (8).<sup>6</sup>

The evidence would also be compatible with the reaction proceeding through a solvent-caged combination of allyl radical and molecular oxygen. This might be stabilized by a charge-transfer interaction which could again be represented by the orbital interaction scheme as shown in (24).

*The  $7\alpha$ -  $\rightarrow$   $7\beta$ -Hydroperoxide Rearrangement.*—This rearrangement, (2)  $\rightarrow$  (10), is slower than that of the  $5\alpha$ -hydroperoxide, (1)  $\rightarrow$  (2). As it is inhibited by 4-methyl-2,6-di-*t*-butylphenol it is again a radical-chain reaction. The lack of oxygen exchange in the reactant, and the substantial but incomplete exchange in the product suggests a dissociative ( $\text{S}_{\text{H}}1$ ) mechanism in which dioxygen can intrude on the  $\beta$ -face but not on the  $\alpha$ -face. An  $\text{S}_{\text{H}}2$  displacement of dioxygen by dioxygen at the  $\text{sp}^3$  carbon (Scheme 8) seems less likely as it would involve complete isotope exchange.

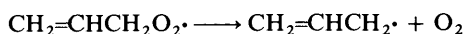


Scheme 8.



(24)

Unimolecular dissociation of the peroxy radical (12) is not unreasonable. The allyl radical is resonance stabilized by 54–59 kJ mol<sup>-1</sup>,<sup>16</sup> and in the gas-phase reaction (8) shows  $A$  ( $1.6 \pm 0.8$ )  $\times 10^{10}$  s<sup>-1</sup> and  $E_a$  53.3  $\pm$  1.6 kJ mol<sup>-1</sup>.<sup>17</sup>



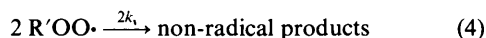
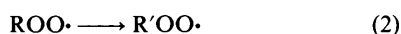
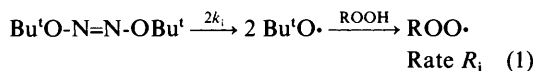
Scheme 9.

*The Effect of Additives.*—Whereas phenols inhibit the rearrangements by reacting with the peroxy radicals, nitroxyl radicals should trap only carbon-centred radicals. However, our attempts to obtain further evidence regarding the mechanisms of the two reactions by the use of nitroxyls as allyl-radical scavengers were unsuccessful. Whereas the lack of any appreciable effect of the nitroxyl (17) on the rearrangement (1)  $\longrightarrow$  (2) would be compatible with the non-dissociative mechanism which we propose, neither did it have any significant effect on the rate of the rearrangement (2)  $\longrightarrow$  (10), which we suggest does involve a free allylic radical. Recently it has become clear that nitroxyl radicals do react with alkyl radicals at rather less than the diffusion-controlled rate,<sup>18</sup> and this, coupled with the problem which (17) may have in penetrating the solvent cage, may account for its ineffectiveness.

The piperidine-based nitroxyl radicals (18) and (19), however, inhibited *both* rearrangements (1)  $\longrightarrow$  (2) and (2)  $\longrightarrow$  (10). We suggest that this may result from quenching of the initiation process rather than capture of an allylic radical. The rates of the reactions are erratic, and it may be that the rate of initiation is sensitive to the presence of adventitious metal ions, which are known to be sequestered by certain nitroxyl radicals.<sup>19</sup> Some support for this model is provided by the fact that EDTA (20) is also an inhibitor.

The inhibiting effect of DABCO may result from the formation of a hydrogen-bonded complex with the hydroperoxide,<sup>20</sup> and this complex is less reactive than the free hydroperoxide in the propagation step (3)  $\longrightarrow$  (4), or it may relate again to the deactivation of metal catalysts.

*Kinetic Studies.*—We assume the kinetic scheme shown below.



ROOH represents the 5 $\alpha$ -hydroperoxide (1) and R'OOH the 7 $\alpha$ -hydroperoxide (2). We assume that, at the concentrations of our experiments, there is no complication from the formation of hydrogen-bonded hydroperoxide dimers. Further we assume that termination is wholly through the secondary alkylperoxy radical R'OO $\cdot$ , since the self-reaction of such radicals usually occurs 10<sup>3</sup> times faster than that of tertiary alkylperoxy radicals.<sup>21</sup>

By the steady-state approximation

$$R_i = 2k_t[\text{R}'\text{OO}\cdot]^2 \quad (5)$$

$$\text{whence } [\text{ROO}\cdot] = (\text{R}_i/2k_t)^{\frac{1}{2}} \quad (6)$$

$$\frac{-d[\text{ROOH}]}{dt} = k_p[\text{R}'\text{OO}\cdot][\text{ROOH}] \quad (7)$$

$$= k_p[\text{ROO}\cdot](\text{R}_i/2k_t)^{\frac{1}{2}} = k_{\text{obs}}[\text{ROOH}] \quad (8)$$

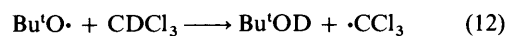
If TBHN is present as initiator, and the relatively slow rate of self-initiation can be ignored

$$R_i = 2k_i[\text{TBHN}] \quad (9)$$

$$\text{and } -d[\text{ROOH}]/dt = k_p[\text{ROOH}](2k_i[\text{TBHN}]/2k_t)^{\frac{1}{2}} = k_{\text{obs}}[\text{ROOH}] \quad (10)$$

During the period  $t$  of 3–4 h for which the reactions were followed, the hyponitrite decomposes to the extent of about 10%,<sup>22</sup> and as an approximation we assume that [TBHN] is constant at  $([\text{TBHN}]_0 + [\text{TBHN}]_t)/2$ .

The formation of some hexachloroethane in the reactions where CDCl<sub>3</sub> was used as a solvent is presumably due to chain-breaking by the reaction (11), accompanied by the reaction (12) when TBHN was used as initiator, followed by dimerization of the  $\cdot\text{CCl}_3$  radicals [equation (13)]. The rate constant for the reaction between Bu<sup>t</sup>O $\cdot$  and CHCl<sub>3</sub> at 300 K is  $4.5 \times 10^5$  dm<sup>3</sup> mol<sup>-1</sup> s<sup>-1</sup>.<sup>23</sup>



When benzene is used as the solvent, chain breaking by the solvent would not be significant, and this is presumably the principal reason why we obtained bigger values of  $k_{\text{obs}}/[\text{TBHN}]^{\frac{1}{2}}$  in benzene than in chloroform.

The good first-order dependence of the rate on [(1)] in both chloroform and benzene, and the approximate half-order dependence on [TBHN] in chloroform, agree with the predictions of equation (10), and, in accordance with the measurements of the i.r. spectra, there is no complication from hydrogen bonding by the hydroperoxide. Schenck<sup>1</sup> followed the rearrangement of (1) polarimetrically in chloroform, and, without giving details, said that the reaction was first order. Brill<sup>6</sup> followed the reversible isomerization of the hydroperoxide (25) in hexane at 40 °C over a period of 1–2 months by g.l.c. analysis of the alcohols which are formed after reduction with triphenylphosphine, and reported that the rate showed an order of 3/2 in total hydroperoxide concentration, with an ultimate equilibrium concentration of (25):(26) = 4:1.

In the absence of added hyponitrite, initiation in our system may be by adventitious metal ion, as suggested by the effect of sequestering additives. Initiation would presumably then be at a rate proportional to total hydroperoxide concentration, and as [ROOH] + [R'OOH] stays essentially constant throughout the period of the reaction, first-order kinetics would still be observed.

From Traylor's work,<sup>22</sup> the value of  $2k_i$  in benzene at 30 °C can be taken to be  $6 \times 10^{-6}$  s<sup>-1</sup>, and  $2k_t$  for a secondary allylperoxy radical can be assumed to be  $5.6 \times 10^6$  dm<sup>3</sup> mol<sup>-1</sup> s<sup>-1</sup> as found for the cyclohex-3-enylperoxy radical.<sup>24</sup> When these values are introduced, equation (10) gives  $k_p = 2.8 \times 10^3$





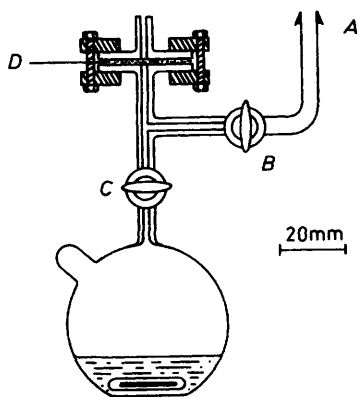


Figure 6. Apparatus for  $^{18}\text{O}_2$  experiments.

spectra were recorded using a Perkin Elmer PE983 instrument on KBr pellets (3–4 mg in 250 mg KBr) or on solutions in  $\text{CDCl}_3$  (3–4 mg in  $0.75\text{ cm}^3\text{ CDCl}_3$ ).

Column chromatography was carried out on Merck silica gel 60 (70–230 mesh), and preparative layer chromatography on silica gel 60 GF $_{254}$ . Peroxides were identified in t.l.c. with an  $N,N,N',N'$ -tetramethyl-*p*-phenylenediamine reagent,<sup>30</sup> and other steroids with  $\text{Ce}^{\text{IV}}$  in alcohol,<sup>31</sup> or with 50% sulphuric acid.<sup>32</sup>

H.p.l.c. separations of the steroids were carried out on 5  $\mu\text{m}$  Lichrosorb silica gel using in series two 25 cm  $\times$  7 mm (i.d.) and one 10 cm  $\times$  4.5 mm columns for the hydroperoxides, and one 25 cm  $\times$  7 mm and one 10 cm  $\times$  4.5 mm column for the alcohols.<sup>33</sup> Melting points are not corrected.

**5 $\alpha$ -Hydroperoxy-3 $\beta$ -hydroxycholest-6-ene (1).**—A solution of cholesterol (0.80 g) and Rose Bengal (0.0085 g) in pyridine (7  $\text{cm}^3$ ) in a water-cooled cell (17  $^\circ\text{C}$ ) was connected to a gas burette containing oxygen at 1 atm. The solution was vigorously stirred magnetically, and irradiated with light from a Thorn 400 W sodium lamp at a distance of 5 cm. The uptake of oxygen ceased after ca. 2 h 40 min.

The pyridine was removed under reduced pressure and the residue was dissolved in chloroform and absorbed on silica. The chloroform was removed under reduced pressure, and the silica was added to the top of a preparative silica chromatography column and eluted with ether–pentane (1:1) to give 0.61 g (70%) of the hydroperoxide. Recrystallization from aqueous methanol gave pure 5 $\alpha$ -hydroperoxy-3 $\beta$ -hydroxycholest-6-ene, m.p. 141–142  $^\circ\text{C}$  (lit.,<sup>34</sup> 145–148  $^\circ\text{C}$  decomp.),  $\delta$  (see Figure 2) 0.69 (3 H, s, 18-H $_3$ ), 0.86 (3 H, d,  $J$  6.58 Hz, 26- or 27-H $_3$ ), 0.87 (3 H, d,  $J$  6.61 Hz, 26- or 27-H $_3$ ), 0.91 (3 H, d,  $J$  6.52 Hz, 21-H $_3$ ), 0.95 (3 H, s, 19-H $_3$ ), 4.12 (1 H, m, 3-H), 5.61 (1 H, dd,  $J$  9.93 and 2.71 Hz, 7-H), 5.83 (1 H, dd,  $J$  10.00 and 2.13 Hz, 7-H);  $m/z$  (70 eV) 400 ( $M^+ - \text{H}_2\text{O}$ );  $\nu_{\text{max}}$  ( $\text{CDCl}_3$ ) 3 606 (O–H str.) and 3 514  $\text{cm}^{-1}$  (OO–H str.).

**7 $\alpha$ -Hydroperoxy-3 $\beta$ -hydroxycholest-5-ene (2).**—The  $\Delta^6$ -5 $\alpha$ -hydroperoxide (1; 0.1 g) was dissolved in chloroform (5  $\text{cm}^3$ ) at room temperature. After 12 h the solvent was removed under reduced pressure and the product was isolated by h.p.l.c. eluting with 9:1 light petroleum (60–80  $^\circ\text{C}$ )/isopropyl alcohol. Recrystallization from hexane–ether gave the pure 7 $\alpha$ -hydroperoxide (0.08 g, 80%), m.p. 152–153  $^\circ\text{C}$  (lit.,<sup>34</sup> 154–156.5  $^\circ\text{C}$ ),  $\delta_{\text{H}}$  (see Figure 2) 0.66 (3 H, s, 18-H $_3$ ), 0.86 (3 H, d, 27-H $_3$ ;  $J$  6.65 Hz), 0.87 (3 H, d, 26-H $_3$ ;  $J$  6.67 Hz), 0.92 (3 H, d,  $J$  6.56 Hz, 27-H $_3$ ), 1.00 (3 H, s, 19-H $_3$ ), 3.62 (1 H, m, 3-H), 4.16 (1 H, m, 7-H), and 5.72 (1 H, dd,  $J$  5.04 and 1.86 Hz, 6-H).

With this information, the n.m.r. spectrum of the 7 $\beta$ -hydroperoxide (10) could be identified in the crude rearrangement product:  $\delta$  0.69 (3 H, s, 18-H $_3$ ), 0.86 (3 H, d,  $J$

6.65 Hz, 27-H $_3$ ), 0.87 (3 H, d,  $J$  6.65 Hz, 26-H $_3$ ), 0.92 (3 H, d,  $J$  6.56 Hz, 21-H $_3$ ), 1.05 (3 H, s, 19-H $_3$ ), 3.59 (1 H, m, 3-H), 4.13 (1 H, m, 7-H), and 5.58 (1 H, t, 6-H; width at half height, 4.68 Hz).

**3 $\beta$ -Hydroxy-5 $\alpha$ -, -7 $\alpha$ -, and 7 $\beta$ -hydroxycholest-5-ene (13), (14), and (15), Respectively.**—The 5 $\alpha$ -, 7 $\alpha$ -, and 7 $\beta$ -hydroperoxides (1), (2), and (10), respectively in ether were reduced with an excess of triphenylphosphine in ether at room temperature, to yield the corresponding 5 $\alpha$ -, 7 $\alpha$ -, and 7 $\beta$ -hydroxy compounds with the following characteristics.

(13):  $\delta$  0.70 (3 H, s, 18-H $_3$ ), 0.86 (3 H, d,  $J$  6.55 Hz, 27-H $_3$ ), 0.87 (3 H, d,  $J$  6.58 Hz, 26-H $_3$ ), 0.92 (3 H, d,  $J$  6.45 Hz, 21-H $_3$ ), 0.92 (3 H, s, 19-H $_3$ ), 4.12 (1 H, m, 3-H), 5.57 (1 H, dd,  $J$  9.82 and 2.52 Hz, 6-H), and 5.63 (1 H, dd,  $J$  9.83 and 1.75 Hz, 7-H).

(14):  $\delta$  0.69 (3 H, s, 18-H $_3$ ), 0.86 (3 H, d,  $J$  6.65 Hz, 27-H $_3$ ), 0.87 (3 H, d,  $J$  6.61 Hz, 26-H $_3$ ), 0.93 (3 H, d,  $J$  6.62 Hz, 21-H $_3$ ), 1.00 (3 H, s, 19-H $_3$ ), 3.59 (1 H, m, 3-H), 3.85 (1 H, m, 7-H), and 5.61 (1 H, dd,  $J$  5.33 and 1.68 Hz, 6-H).

(15):  $\delta$  0.69 (3 H, s, 18-H $_3$ ), 0.86 (3 H, d, 6.61 Hz, 27-H $_3$ ), 0.87 (3 H, d,  $J$  6.79 Hz, 26-H $_3$ ), 0.92 (3 H, d,  $J$  6.49 Hz, 21-H $_3$ ), 1.05 (3 H, s, 19-H $_3$ ), 3.55 (1 H, m, 3-H), 3.85 (1 H, m, 7-H), and 5.30 (1 H, t, 6-H).

**Isotopic Experiments.**—Experiments using  $^{18}\text{O}_2$  gas were carried out in the apparatus shown in Figure 6. The flask (volume ca. 55  $\text{cm}^3$ ) was connected to the vacuum line through the joint A, and evacuated to 0.005 mmHg.  $^{18}\text{O}_2$  gas (99% isotopic purity) was condensed by cooling with liquid nitrogen into the flask to a pressure of 0.95 atm, then tap B was closed and the flask was removed from the vacuum line.

A solution of the  $\Delta^6$ -5 $\alpha$ -hydroperoxide (1); [0.025 g in chloroform (2.5  $\text{cm}^3$ )] was injected through the silicone rubber septum D and tap C into the flask, then tap C was closed and the seal D was replaced. The flask was connected to the MS-9 mass spectrometer at A, and evacuated up to the tap C. Tap B, was closed, and tap C, was opened then closed, and the gas between the two taps was analysed.

The solution was stirred vigorously for 3.5 h, then the gas phase was analysed again by the same procedure.

The solution was removed by syringe through D and C, and the solvent was removed under reduced pressure. The mixed hydroperoxides were reduced with triphenylphosphine, and the products were separated by preparative h.p.l.c. using initially ethyl acetate as the eluant to remove the triphenylphosphine oxide, then ethyl acetate–light petroleum (1:1) to separate the diols (13), (14), and (15) which were analysed by  $^1\text{H}$  n.m.r. and mass spectroscopy (e.i. at 18 eV; Figures 3 and 4).

The results of three such experiments were as follows.

(i) The hydroperoxide (1) (20 mg) gave the diols (13) (2.85 mg, 0%  $^{18}\text{O}$ ), (14) (8.00 mg, 0%  $^{18}\text{O}$ ), and (15) (1.01 mg, 82%  $^{18}\text{O}$ ) and  $\text{Ph}_3\text{PO}$  (9.5%  $^{18}\text{O}$ ).

(ii) The hydroperoxide (1) (27 mg) gave the diols (13) 4.86 mg, 0%  $^{18}\text{O}_2$ , (14) (10.65 mg, 0%  $^{18}\text{O}_2$ ), and (15) (0.91 mg, 83%  $^{18}\text{O}_2$ ) and  $\text{Ph}_3\text{PO}$  (9.4%  $^{18}\text{O}$ ).

(iii) The hydroperoxide (2) (25 mg) gave the diols (14) (15.82 mg, 0%  $^{18}\text{O}$ ) and (15) (0.45 mg, 73%  $^{18}\text{O}_2$ ), and  $\text{Ph}_3\text{PO}$  (3.3%  $^{18}\text{O}$ ).

**The Effect of Additives.**—The rearrangement (1)  $\rightarrow$  (2) and/or (2)  $\rightarrow$  (10) were monitored by n.m.r. spectroscopy, using the reactant (5 mg) in the solvent (0.5  $\text{cm}^3$ ), together with the appropriate additives (16)  $\rightarrow$  (21) as shown in Table 1. Usually a blank reaction, with no additive was followed in parallel.

**Kinetic Experiments.**—The 5 $\alpha$ -hydroperoxide (1) (3–4.5 mg) was weighed accurately into an n.m.r. tube, and an aliquot of a solution of TBHN (ca. 3 mg) in  $\text{CDCl}_3$  or  $\text{C}_6\text{D}_6$  (1  $\text{cm}^3$ ) was

added to give a mole ratio of (1):TBHN of between 1:0.3 and 1:1. The solution was then diluted to a total volume of 750 mm<sup>3</sup>.

The sample was immediately introduced into the probe of the VXR 400 spectrometer, thermostatted at 20 or 30 °C. Proton spectra were recorded automatically every 15–20 min; 32 transients were collected in 152 s, using a 1.74 s acquisition time and a 3 s delay. The points were timed at the recording of the first transient.

The concentration of the hydroperoxide (1) was determined from the integration of the low-field doublet of doublets between  $\delta$  5.81 and 5.87 for the alkenic protons [see Figure 1 where a trace of the signal of the alkenic proton of (2) can be detected at  $\delta$  5.71–5.74]. In some experiments hexamethylcyclotrisiloxane was added as an internal concentration standard.

As the reaction progresses, the upfield doublet of doublets at  $\delta$  5.58–5.64 becomes contaminated by the signal for the 7 $\beta$ -hydroperoxide (10) at  $\delta$  5.56–5.60, and the concentration of (10) can be obtained from the difference between the integrations of the signals between  $\delta$  5.81–5.87 and 5.56–5.64. This is of limited accuracy however because the yield of (10) was never more than ca. 15%.

**3 $\beta$ -Benzoyloxy-7 $\alpha$ -bromocholest-5-ene.**—A solution of cholest-5-en-3 $\beta$ -yl benzoate (3.0 g) and *N*-bromosuccinimide (1.4 g) in CCl<sub>4</sub> was heated under reflux for 30 min. The succinimide was filtered off, and the solvent was removed to leave an oil which was recrystallized from acetone at 0 °C, to give the bromo benzoate (1.4 g, 40%), m.p. 132 °C (lit.,<sup>14</sup> 135–137 °C),  $\delta$  0.72 (3 H, s, 18-H<sub>3</sub>), 1.09 (3 H, s, 19-H<sub>3</sub>), 4.69 (1 H, m, 7-H), 4.95 (1 H, m, 3-H), 5.80 (1 H, d, *J* 5.2 Hz, 6-H), 7.48 (4 H, m, Ph), and 8.05 (1 H, d, Ph).

**7 $\alpha$ -Hydroperoxy-3 $\beta$ -methoxycholest-5-ene.**—The potassium salt of cholesterol was treated with methyl iodide to give the methyl ether (58%), m.p. 82–83 °C (lit.,<sup>35</sup> 84 °C),  $\delta$  0.68 (3 H, s, 18-H<sub>3</sub>), 1.00 (3 H, s, 19-H<sub>3</sub>), 3.06 (1 H, m, 3-H), 3.36 (3 H, s, MeO), and 5.36 (1 H, br d, 6-H); *m/z* 400 (*M*<sup>+</sup>).

This methyl ether was treated with singlet oxygen in pyridine for 2.5 h, and the hydroperoxide was isolated by chromatography using pentane–ether (5:3) as the eluant. The <sup>1</sup>H n.m.r. spectrum showed that the product was >95% 7 $\alpha$ -hydroperoxide,  $\delta$  0.66 (3 H, s, 18-H<sub>3</sub>), 0.98 (3 H, s, 19-H<sub>3</sub>), 3.16 (1 H, m, 3-H), 3.37 (3 H, s, MeO), 4.16 (1 H, m, 7-H), 5.73 (1 H, d, *J* 4.94 Hz, 6-H), and 7.63 (1 H, s, OOH).

**7 $\alpha$ -Hydroperoxy-3 $\beta$ -trimethylsilyloxycholest-5-ene.**<sup>36</sup>—Cholesterol was trimethylsilylated with bis(trimethylsilyl)urea to give the 3 $\beta$ -trimethylsilyloxy derivative (95%), m.p. 120–121 °C (lit.,<sup>37</sup> 121–123 °C),  $\delta$  0.67 (3 H, s, 18-H<sub>3</sub>), 1.00 (3 H, s, 19-H<sub>3</sub>), 3.49 (1 H, m, 3-H), and 5.34 (1 H, br d, 6-H); *m/z* 458 (*M*<sup>+</sup>).

This derivative was caused to react with singlet oxygen as described above, to yield, after 3 h, the 7 $\alpha$ -hydroperoxide (54%), m.p. 99–101 °C (Found: C, 73.3; H, 11.0. C<sub>30</sub>H<sub>54</sub>O<sub>3</sub>Si requires C, 73.4; H, 11.1%;  $\delta$  0.10 (9 H, s, Me<sub>3</sub>Si), 0.63 (3 H, s, 18-H<sub>3</sub>), 0.96 (3 H, s, 19-H<sub>3</sub>), 3.55 (1 H, s, 3-H), 4.12 (1 H, m, 7-H), 5.67 (1 H, d, *J* 4.70 Hz, 6-H), and 8.01 (1 H, s, OOH); *m/z* 472 (*M*<sup>+</sup> – H<sub>2</sub>O).

**3 $\beta$ -Acetoxy-7 $\alpha$ -hydroperoxycholest-5-ene.**—A solution of cholest-5-en-3 $\beta$ -yl acetate (0.79 g) and Rose Bengal (0.01 g) in pyridine (7 cm<sup>3</sup>) was irradiated for 3 h under the same conditions as described for cholesterol. The pyridine was removed at 50 °C, and the product (0.49 g, 58%) was isolated by chromatography using pentane–ether (7:1) as the eluant. Recrystallization from aqueous methanol gave the pure 7 $\alpha$ -hydroperoxide (0.28 g, 33%), m.p. 139–141 °C (lit.,<sup>34</sup> 142–142.5 °C),  $\delta$  0.65 (3 H, s, 18-H<sub>3</sub>), 1.00 (3 H, s, 19-H<sub>3</sub>), 2.04 (3 H, s, MeCO), 4.14 (1 H, m, 7-H), 4.68 (1 H, br m, 3-H<sub>ax</sub>), 5.73 (1 H, d, *J* 4.6 Hz, 6-H), and 7.99 (1 H, s, OOH).

When the reaction was carried out in the presence of 2,6-di-*t*-butyl-4-methylphenol (10 mol%), the product (65% yield) consisted (shown by n.m.r. spectroscopy) of a mixture of 34% of the  $\Delta^6$ -5 $\alpha$ -hydroperoxide and 66% of the  $\Delta^5$ -7 $\alpha$ -hydroperoxide.

### Acknowledgements

We acknowledge extensive help with the g.l.c. and h.p.l.c. separations by Mr. S. T. Corker, and support from the SERC.

### References

- G. O. Schenck, O.-A. Neumüller, and W. Eisfeld, *Justus Liebig's Ann. Chem.*, 1958, **618**, 202.
- B. Lythgoe and S. Trippett, *J. Chem. Soc.*, 1959, 471.
- A. A. Frimer, *Chem. Rev.*, 1979, **79**, 359.
- R. W. Denney and A. Nickon, *Org. React.*, 1973, **20**, 133.
- W. E. Brill, *J. Am. Chem. Soc.*, 1965, **87**, 3286.
- W. F. Brill, *J. Chem. Soc., Perkin Trans. 2*, 1984, 621.
- N. Porter and P. Zuraw, *J. Chem. Soc., Chem. Commun.*, 1985, 1472.
- N. Porter and J. S. Wujek, *J. Org. Chem.*, 1987, **52**, 5085.
- J. I. Teng, M. J. Kulig, L. L. Smith, G. Kan, and J. E. Van Lier, *J. Org. Chem.*, 1973, **38**, 119.
- D. Avila, A. G. Davies, and I. G. E. Davison, *J. Chem. Soc., Perkin Trans. 2*, 1988, 1847.
- J. E. Bennett and R. Summers, *J. Chem. Soc., Faraday Trans. 2*, 1973, **69**, 1043.
- C. L. Sevilla, D. Becker, and M. D. Sevilla, *J. Phys. Chem.*, 1986, **90**, 2963.
- L. L. Smith, 'Cholesterol Autoxidation,' Plenum Press, New York, 1981; J. E. Van Lier and L. L. Smith, *J. Org. Chem.*, 1970, **35**, 2627.
- J. Redel and B. Gauthier, *Bull. Soc. Chim. Fr.*, 1948, **15**, 607.
- J. A. Howard, J. C. Tait, and S. B. Tong, *Can. J. Chem.*, 1979, **57**, 2761.
- H.-G. Korth, H. Trill, and R. Sustmann, *J. Am. Chem. Soc.*, 1981, **103**, 4483.
- C. A. Morgan, M. J. Pilling, J. M. Tulloch, R. P. Ruiz, and K. I. Bayes, *J. Chem. Soc., Faraday Trans. 2*, 1982, **78**, 1323.
- J. Chateaufneuf, J. Luszyk, and K. U. Ingold, *J. Org. Chem.*, 1988, **53**, 1629; A. L. J. Beckwith, V. W. Bowry, and G. Moad, *ibid.*, 1632.
- G. R. Eaton and S. S. Eaton, *Coord. Chem. Rev.*, 1978, **26**, 207.
- A. A. Oswald, F. Noel, and A. J. Stephenson, *J. Org. Chem.*, 1961, **26**, 3969; A. A. Oswald, K. Griesbaum, and B. E. Hudson, *ibid.*, 1963, **28**, 2351.
- J. A. Howard, 'Free Radicals,' ed. J. K. Kochi, Wiley, New York, 1973, ch. 12.
- H. Kiefer and T. G. Traylor, *Tetrahedron Lett.*, 1966, 6163.
- C. Chatgililoglu, J. C. Scaiano, and K. U. Ingold, *Organometallics*, 1982, **1**, 466.
- J. A. Howard and K. U. Ingold, *Can. J. Chem.*, 1966, **44**, 1119.
- J. A. Howard, K. U. Ingold, and W. J. Schwalm, *Adv. Chem. Ser.*, 1968, **75**, 6.
- A. L. J. Beckwith, A. G. Davies, I. G. E. Davison, A. Maccoll, and M. H. Mruzek, *J. Chem. Soc., Chem. Commun.*, 1988, 475.
- A. L. J. Beckwith and P. K. Tindal, *Aust. J. Chem.*, 1971, **24**, 2099; A. L. J. Beckwith and C. B. Thomas, *J. Chem. Soc., Perkin Trans. 2*, 1973, 861; A. J. B. Beckwith, L. Radom, and S. Saebo, *J. Am. Chem. Soc.*, 1984, **106**, 5119.
- H. W.-S. Chan, G. Levett, and J. A. Matthew, *J. Chem. Soc., Chem. Commun.*, 1978, 756; *Chem. Phys. Lipids*, 1979, **24**, 245.
- A. L. J. Beckwith, D. M. O'Shea, and D. H. Roberts, *J. Am. Chem. Soc.*, 1986, **108**, 6408.
- L. L. Smith and F. L. Hill, *J. Chromatogr.*, 1972, **66**, 101.
- W. B. Motherwell, personal communication.
- L. L. Smith, W. S. Mathews, J. C. Price, R. C. Bachmann, and B. Reynolds, *J. Chromatogr.*, 1967, **27**, 187.
- G. A. S. Ansari and L. L. Smith, *J. Chromatogr.*, 1979, **175**, 307.
- A. Nickon and J. F. Bagli, *J. Am. Chem. Soc.*, 1961, **81**, 6330; 1963, **83**, 1498.
- C. R. Narayanan and K. N. Iyer, *J. Org. Chem.*, 1965, **30**, 1734.
- W. Verboom, G. W. Visser, and D. H. Reinhoudt, *Synthesis*, 1981, 807.
- J. Diekmann and C. Djerassi, *J. Org. Chem.*, 1967, **32**, 1005.