

A New Reaction Vessel for Accelerated Syntheses using Microwave Dielectric Super-heating Effects‡

David R. Baghurst and D. Michael P. Mingos*†

Inorganic Chemistry Laboratory, University of Oxford, South Parks Road, Oxford OX1 3QR, UK

Using a thick-walled glass reaction vessel a number of transition-metal organometallic and co-ordination compounds have been synthesised using microwave dielectric super-heating effects. Super-heating by 40–60 °C is maintained by controlling the pressure at 10 atm and results in a decrease in the reaction time required for conventional reflux reactions by a factor of *ca.* 10². Full details of the design of the apparatus, the modification of a conventional microwave oven and the electrical circuitry for the pressure control are provided.

During the past two years several groups have demonstrated that chemical syntheses may be dramatically accelerated using microwave dielectric heating effects. The method which has been recently reviewed¹ is applicable to organic reactions,² the synthesis of transition^{3,4} and post-transition metal organometallic⁵ and co-ordination compounds⁶ and the formation of a range of intercalation⁷ and zeolite materials.¹

In these microwave-accelerated reactions solvents exhibiting high dielectric loss tangents are chosen as the reaction medium. These solvents couple effectively with the microwaves inside a microwave cavity. The presence of dissolved salts increases the conductivity and hence the dielectric-loss tangent. A domestic microwave oven provides an effective and inexpensive way of providing a multimode microwave cavity operating at 2.45 GHz. Volatile solvents rapidly generate high temperatures and pressures inside the closed vessels when exposed to microwaves and their safe containment must be addressed if this technique is to be used routinely in synthetic chemistry. These super-heating conditions lead directly to an acceleration in the reaction times compared with conventional reflux conditions.

Commercially available Teflon containers incorporating pressure-release mechanisms can operate under ideal conditions up to 80 atm (Parr Instrument Co., Moline, IL). The super-heating associated with this mode of containment can lead to rate enhancements of 10³, however the Teflon containers have several disadvantages. First, and perhaps most significantly, the Teflon vessels were not designed for high-boiling solvents (> 200 °C) and viscous solutions but for the acid digestion of mineral and biological samples. The creep properties of Teflon above 150 °C lead to distortions of the autoclave and a decrease in the pressure which can be successfully maintained. Thus we have found that the vessels can fail with explosive consequences even when pressure-release safety mechanisms have been incorporated into the design. The pressure limitations associated with the Teflon autoclave were frequently achieved after only 20–30 s of exposure to microwaves and for many reactions it proved necessary to complete the reaction by using four to six cycles of 20 s microwave heating followed by cooling for 20 min. Secondly there is no means of viewing the reaction mixture while the reaction is in progress. Thirdly, it is not usually possible to monitor the temperature and pressure within the Teflon autoclave. Fourthly, the porosity of the Teflon means that

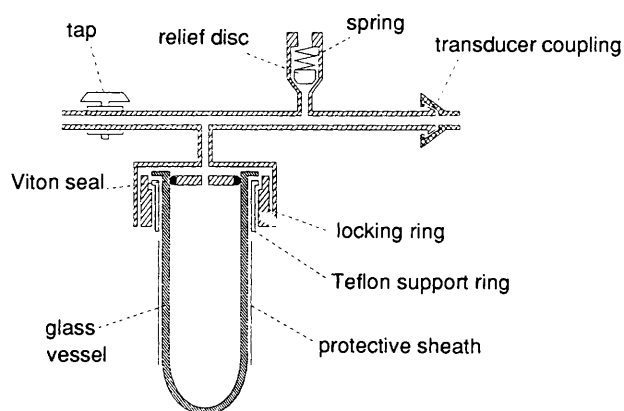

Fig. 1 Modified Fischer-Porter reaction vessel

reaction liners can be contaminated with absorbed impurities. Replacement of these liners is expensive though necessary if subsequent reactions are to proceed without contamination.

In this paper we describe a Pyrex reaction vessel which can be admitted through the roof of a microwave oven using a suitably designed port. Pressure measurement and control has been introduced by external electronic circuitry linked to the microwave power supply. The pressure vessel resembles a Fischer-Porter bottle routinely used in organometallic syntheses where pressures in the range 5–10 atm are required. The more durable glass vessel not only allows a visual examination of the reaction mixture and control of the atmosphere in which the reaction takes place but also can be used with higher-boiling solvents for longer periods of time than the Teflon vessels described in previous papers. The new reaction vessel thereby provides a convenient and inexpensive method for performing super-heating experiments which result in a large decrease in the reaction times for common inorganic and organometallic syntheses.

Apparatus

The design of the Pyrex reaction system is shown in Fig. 1. A port in the form of a copper 'choke' has been attached to the interior roof of a domestic microwave oven. The glass vessel passes through this choke and through a hole drilled in the top of the microwave cavity. Such chokes should be of a diameter of less than the wavelength of the microwave radiation; in this case for a wavelength of around 12 cm (frequency of 2.45 GHz) choke diameters not greater than 4 cm and at least one

† Present address: Department of Chemistry, Imperial College of Science, Technology and Medicine, South Kensington, London, SW7 2AY, UK.

‡ Non-SI units employed: atm = 101 325 Pa, bar = 10⁵ Pa, lbf in⁻² ≈ 6.89 × 10³ Pa.

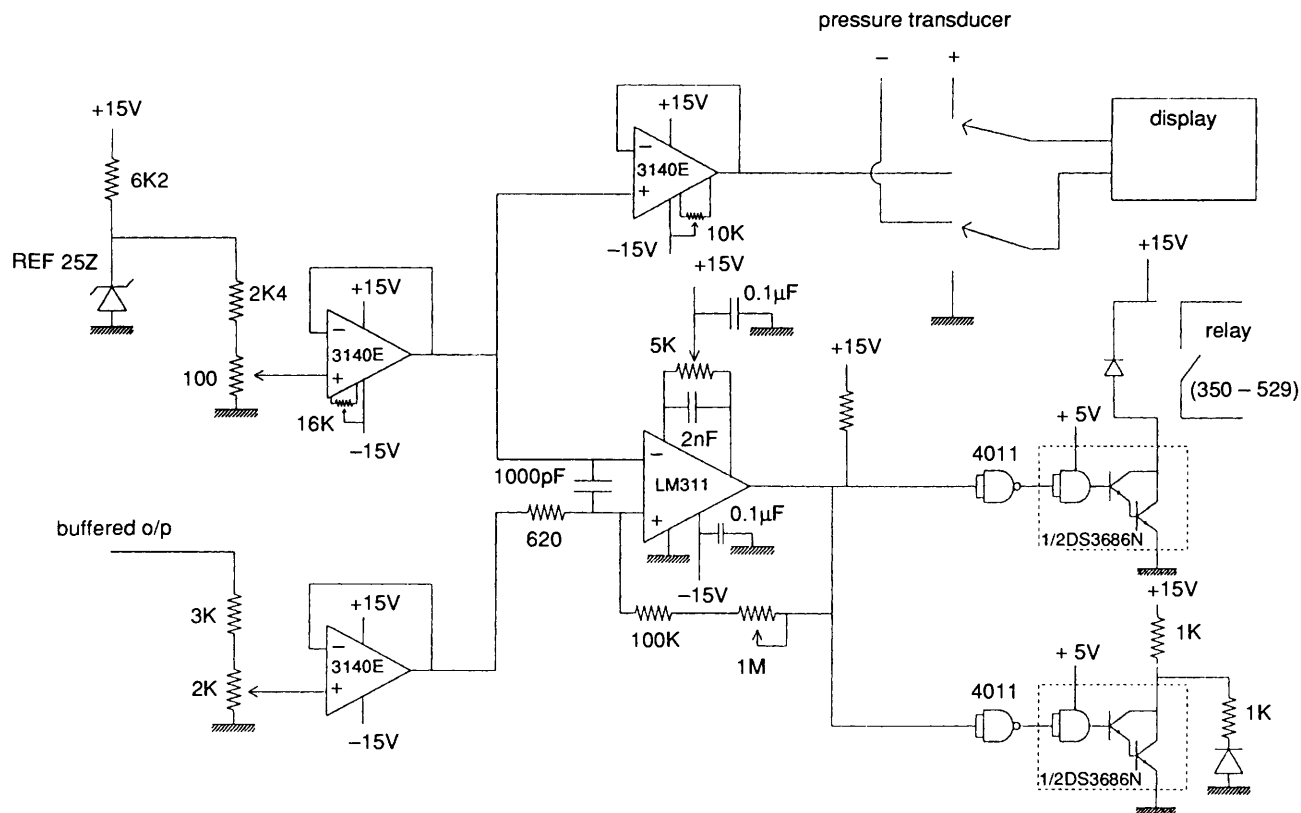

Fig. 2 Pressure-control circuitry

wavelength long are required. This prevents leakage of dangerous levels of microwave radiation from the microwave oven. The extent of leakage as measured using a commercially available hand-held instrument (Apollo Enterprises, Thornton Heath) was less than 1 mW cm^{-2} .

The Pyrex vessels used in our studies were made from 3 cm outer diameter tubing having a wall thickness of 4.5 mm. The tubing has a maximum pressure rating of 30–35 atm at room temperature, but the pressure vessel has been used in the range 10–12 atm for safety reasons. Each tube is about 20 cm long and is covered in a protective sheath made from transparent polyolefin electricians' heat-shrink (R. S. Components, Corby, Northants). In the event of vessel failure the sheath prevents fragmentation of the glass tube. The glass vessel is attached to a series of Swagelok fittings *via* a Viton sealed stainless-steel joint. It is possible to construct high-pressure lines incorporating thermocouples and thermistors, pressure transducers, spring-loaded blow-off valves and two- or three-way taps. In Fig. 1 a pressure transducer, blow-off valve and two-way tap are shown. The adjustable safety valve prevents the pressure exceeding 12 atm. This pressure may be adjusted by tightening the hex-socket retaining the blow-off stopper. The two-way tap may be opened slowly to allow excess of pressure, perhaps as a result of gas evolution during a reaction, to be bled away. Some care has to be taken to calibrate and maintain the pressure transducer. Error is introduced by allowing the transducer to heat up. Also some reaction solvents would damage the transducer. In our experience by filling the tube connecting the reaction vessel to the transducer with a non-aggressive solvent such as water or an alcohol, and rigorously cleaning the transducer housing after use, no problems have been encountered with its operation. An illustration of the modified Fischer-Porter reaction vessel and the manner in which it is incorporated into the microwave cavity is given in Plate 1.

Pressure Control

The output from the pressure transducer is fed directly into a

pressure monitor which may be calibrated in any units but in this apparatus it is calibrated in atmospheres. From the pressure monitor a linear (0–2 V) voltage output is fed into a comparator circuit which compares the output with the predetermined reaction hold pressure. When the pressure is below the set pressure the magnetron is turned on at the full power of 500 W. On reaching the set pressure the comparator which controls a relay incorporated in series with the magnetron turns the supply off. The circuit diagram is shown in Fig. 2. It is noteworthy that the hysteresis in the circuit can be controlled. On/off switching needs to be fast enough to ensure that microwave power is removed before dangerous pressures are achieved but not so fast that the magnetron is damaged by overheating. The hysteresis in this particular circuit is adjustable between 0.5 and 2 atm.

Solvent Heating Tests

In order to establish which solvents could be heated rapidly and effectively using a 500 W domestic microwave oven several blank runs were performed where solvents alone were loaded into the glass vessel. It was envisaged that the volumetric nature of microwave heating would determine that the volume as well as the dielectric-loss properties of the solvent would have a profound effect on the 'coupling' ability of a particular solvent mixture.

The effect of solvent volume on pressure build-up for water and ethanol has been investigated. It appears that the optimum volume for efficient heating is around 20–30 cm^3 . Thus when the volume is very small only a small fraction of the available microwave energy is absorbed by the sample. Additionally the surface area to volume ratio ensures that the radiative heat loss is comparatively high. For larger volumes there is insufficient microwave energy available from the source to heat the large volume of solvent as rapidly.

In Fig. 3 the variation in super-heating with reaction solvent is illustrated. Those solvents which have high dielectric-loss tangents and low boiling points are heated most rapidly and generate high pressures most quickly. Note that the rate of

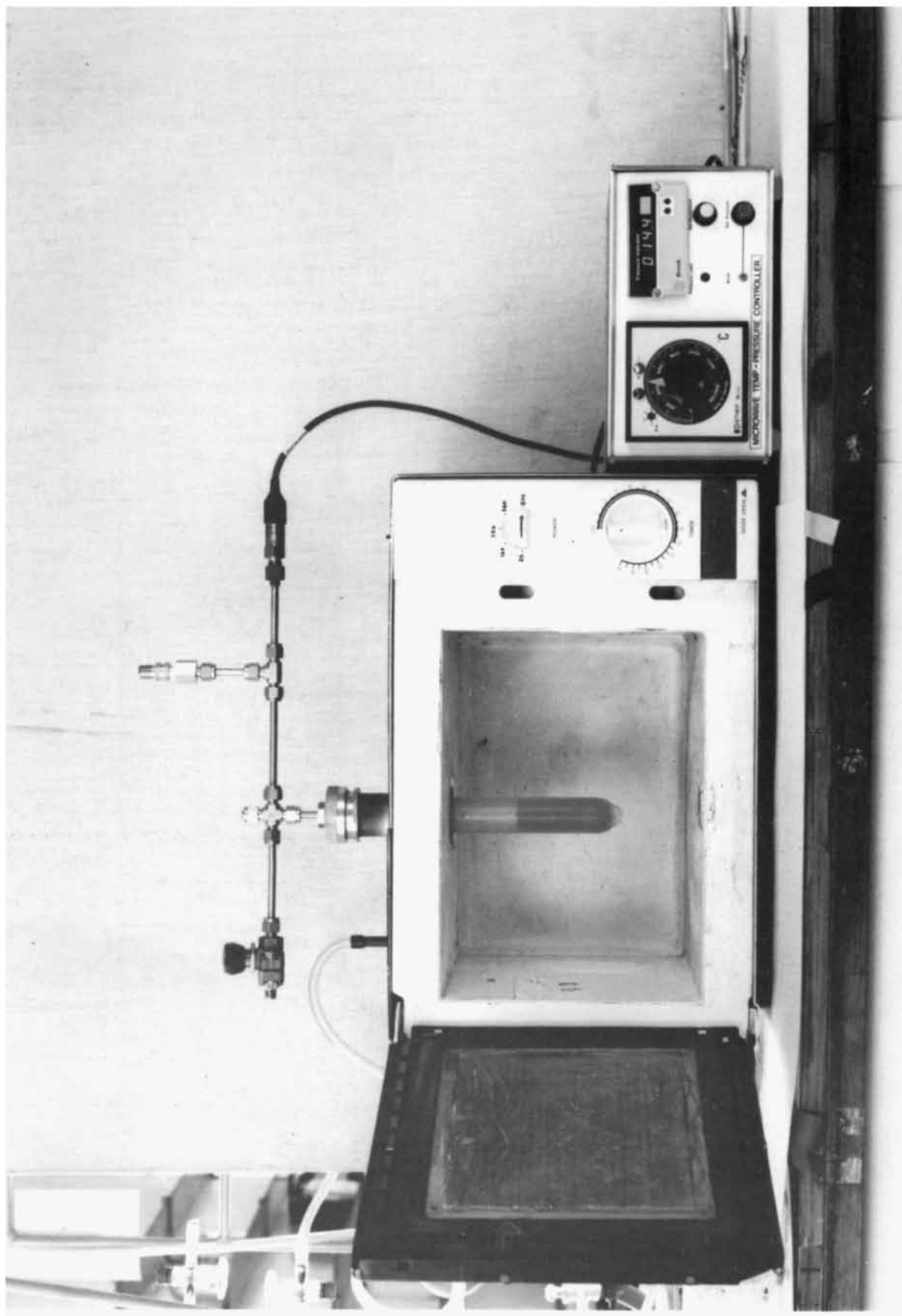

Plate 1 A modified domestic microwave oven incorporating the Fischer-Porter reaction vessel. The controller circuitry is housed in the enclosure on the right

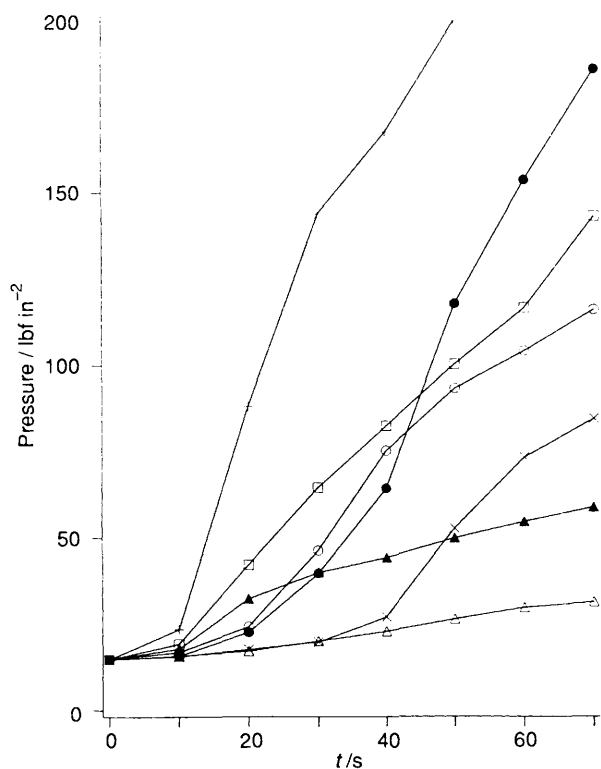

Fig. 3 Influence of solvent on the pressure development. Solvents: methanol (+), ethanol-water (1:1) (●), ethanol (□), isopropyl alcohol (○), water (×), acetone (▲) and ethyl acetate (△)

Table 1 Temperature reached after 10 min of microwave heating to 10 atm

Solvent	$T/^\circ\text{C}$	B.p./ $^\circ\text{C}$
Methanol	106	65
Ethanol	117	78
Acetonitrile	142	82
Dimethylformamide	205	153

pressure increase for water-ethanol (1:1) is faster than that seen for either ethanol or water alone. The influence of the water on the ethanol is to increase the dielectric-loss tangent of the solution relative to pure ethanol. In addition, relative to pure water, the boiling point of the solution has been decreased by the addition of the more volatile ethanol. High-boiling alcohols and low-polarity solvents only generate high pressures on prolonged heating, if at all. The presence of ions in solution can have a profound effect on the pressure generated inside the reaction vessel. In Fig. 4 the increase in pressure for 20 cm³ of a range of concentrations of aqueous KCl solution is illustrated. Note that while the presence of ions leads to greater coupling when at relatively low concentrations, too great a concentration of ions reduces the heating rate because the solution reflects a large proportion of the available microwave energy. These preliminary studies show that solvent volumes of 20–30 cm³ with initial ionic concentrations kept to around 0.1 mol dm⁻³ will provide for most effective super-heating.

The measurement of pressures provides for pressure control during the reactions. Measurement of reaction temperature has been achieved using a hand-held infrared pyrometer to sample reaction temperatures between magnetron pulses. In Table 1 the temperature reached following microwave heating for 10 min at a constant pressure of 10 atm is shown along with the boiling points of a range of common solvents. In general the microwave reactions take place at around 40–60 °C above the normal

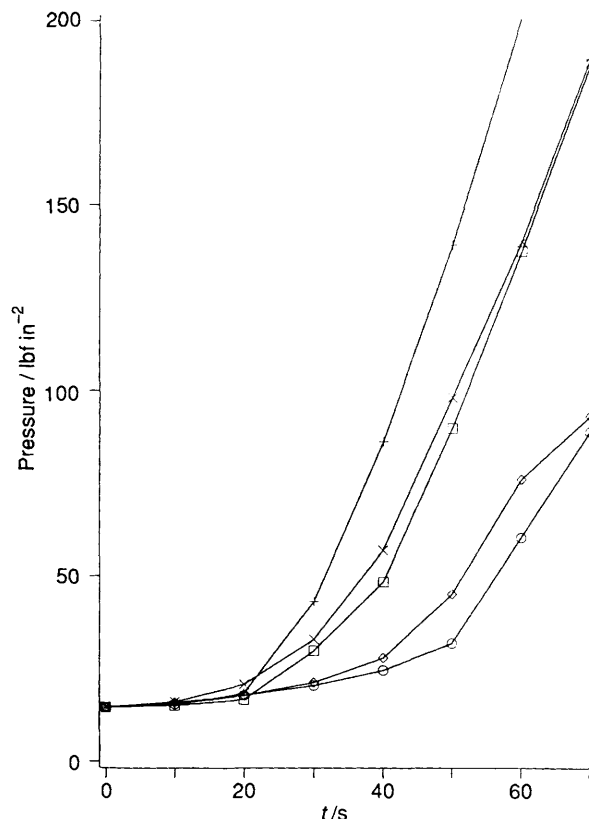

Fig. 4 Influence of the concentration of KCl on the heating rate. Concentration: 0.1 (+), 0.01 (×), 1 (□), water (◇), and 0.001 mol dm⁻³ (○)

reflux temperature. It is possible to estimate the rate enhancement of a reaction using elementary kinetics. If the reaction temperature is increased by 50 °C then the time for 90% completion is reduced from 12–24 h to 10–20 min, corresponding to a rate enhancement of the order of 10². Although technically this type of super-heating could be achieved using a Fischer-Porter bottle resistively heated, the microwave dielectric heating technique has considerable advantages in terms of convenience, speed of heating and reaction visibility.

Synthetic Applications

Table 2 summarises examples of reactions studied by this technique. The microwave syntheses of $[\{\text{Rh}(\text{cod})\text{Cl}\}_2]$ (cod = cycloocta-1,5-diene), $[\text{RuL}_2]^{2+}$ (L = 1,4,7-trithiacyclonane) and $[\text{Ru}(\text{bipy})_3]^{2+}$ (bipy = 2,2'-bipyridine) employing sealed Teflon vessels have previously been reported. By comparison with this earlier work³ the synthesis of $[\{\text{Rh}(\text{cod})\text{Cl}\}_2]$ shows a dramatic improvement on the conventional 18 h reflux. The synthesis¹¹ of $[\text{Ru}(\text{bipy})_3]^{2+}$ has been improved somewhat in terms of yield (87 versus 68%) and reaction time. In our early studies⁴ good yields of the product were obtained only after three 20 s pulses of microwave heating separated by 20 min of cooling. Longer heating times led to the generation of too great a pressure in the Teflon containers. Using the pressure-controlled apparatus described in this paper it is no longer necessary to use such a sequential process and the reaction can be run continuously for long periods of time. Additionally the vessel cools much faster and can usually be opened 10 min after the reaction has been completed.

Similarly the previous microwave synthesis⁶ of $[\text{RuL}_2]^{2+}$ took six pulses of 25 s duration to give 49% yield of the hexafluorophosphate salt on work-up. Using the clear glass vessel it is possible to see the insoluble intermediate monosubstituted compound $[\text{RhLCl}_3]$ gradually redissolving to give

Table 2 Examples of reactions studied in the modified Fischer-Porter reaction vessel

Product	Solvent	Literature synthesis	Microwave		
			T/min	Yield (%)	Reaction temperature/°C
[Mo ₂ (acac) ₄]	MeCO ₂ H	See text ^{8,9}	30	65	195
[RuL ₂][PF ₆] ₂	MeOH	See text ¹⁰	70	96	117
[Ru(bipy) ₃][PF ₆] ₂	MeOH	72 h, EtOH, 95% ¹¹	10	87	133
[{Ru(C ₇ H ₈ Cl ₂) ₂ }] ₂	EtOH	12 h, 85% ¹²	9	66	135
[{Rh(cod)Cl} ₂]	EtOH-water (4:1)	18 h, 94% ¹³	0.5	84	140
[Mo ₆ Cl ₈][O ₂ CMe] ₂ Cl ₂ ^b	MeCO ₂ H	See text ⁹	8	79	155

^a acac = Acetylacetonate, C₇H₈ = cycloheptatriene. ^b 7 atm.

the soluble disubstituted product. Long reaction times (70 min) give excellent yields (96%) of the desired product which conventionally has previously been synthesised¹⁰ only by prior conversion of the unreactive RuCl₃ into the labile intermediates [Ru(SO₃CF₃)₃] or [Ru(Me₂SO)₆]²⁺.

The most commonly cited preparation of [Mo₂(acac)₄]⁸ indicates a reflux time of 20 h and a yield of 37%, though other authors⁹ report yields of up to 85% following 8 h of reflux in ethylene glycol under nitrogen. While sealed Teflon vessels were found to give 75% yield in 15 min¹ it was found that the high temperatures associated with refluxing acetic acid rapidly led to distortion of the Teflon vessels. Additionally loading the reaction vessel under nitrogen proved to be troublesome. The new vessel can be attached directly to a Schlenk line and temperatures of 200 °C for extended reaction times provide no problems for the glass reaction vessel.

Other examples of reactions which can be accelerated by the application of microwaves include the syntheses of [Mo₆Cl₈]-[O₂CMe]₂Cl₂ and [{Ru(C₇H₈Cl₂)₂}]₂. The conventional synthesis of the former requires a reflux for 2 d or sealed-tube reaction between MoCl₂ and acetic acid,⁹ while the latter involves a reflux for 12 h in ethanol.¹² Using the modified Fischer-Porter reactor the reactions are accelerated by a factor of *ca.* 10².

Conclusion

The apparatus described in this paper has overcome many of the disadvantages associated with the Teflon autoclave previously reported. In particular the pressure of the reaction vessel can be monitored and controlled and therefore the reaction time can be varied to optimise the yield of the reaction. The reaction can be viewed throughout this time in order to ascertain when it has reached completion. The pressure limitations associated with the glass reaction vessel set an upper limit of approximately 10–12 atm for its safe operation. This results in a super-heating of the reaction solution by approximately 40–60 °C and a reaction time decrease by a factor of *ca.* 10². The glass vessel permits the use of higher-boiling solvents than those which may be used with the Teflon autoclave.

In summary, the apparatus and associated modifications to a domestic microwave oven provide a convenient and inexpensive way of using microwave dielectric heating effects to super-heat and thereby accelerate a wide range of inorganic and organo-metallic synthetic reactions which commonly require days of refluxing to achieve reasonable yields. This technique will be particularly suitable for synthesising compounds which are thermodynamically robust but are the end products of kinetically slow reactions.

We have most recently applied this technique to the synthesis of platinacarboranes. Here the conventional reflux procedures gave only trace amounts of products after several days' reaction time. However using the microwave technique we have been able to synthesise and characterise fully two new compounds.¹⁴

Experimental

The compound RuCl₃·3H₂O was donated by Johnson Matthey plc and was freed of residual acid by dissolving 10 g in water (100 cm³) and boiling to dryness. All the reactions were performed in a modified Swan Compact model 20701 domestic microwave oven which has a maximum power setting of 500 W. The Druck Ltd. PDCR 810-0799 0–35 bar pressure transducer and associated pressure indicator were purchased from RS Components. Microanalyses were carried out by Mr. M. Gascoyne and his staff of this laboratory.

With the exception of [RuL₂][PF₆]₂, for which the relevant details are given below, the compounds described in this paper were synthesised using published reaction procedures. The precise quantities used and the details of microanalyses of the products were as follows: [Mo₂(acac)₄], reactants [Mo(CO)₆]₂ (0.49 g), acetic acid (20 cm³) and acetic anhydride (4 cm³) (Found: C, 22.6; H, 2.70. Calc. for C₈H₁₂Mo₂O₄: C, 22.4; H, 2.85%); [Ru(bipy)₃][PF₆]₂, precipitated by the addition of KPF₆ (0.67 g) in water (15 cm³) to the deep red-orange reaction solution, collected by filtration, red-brown solid recrystallised from acetone-ethanol, reactants RuCl₃·3H₂O (0.27 g), bipy (0.62 g), MeOH (25 cm³) and NEt₃ (1.5 cm³) (Found: C, 42.1; H, 2.80; N, 9.7. Calc. for C₃₀H₂₄F₁₂N₆P₂Ru: C, 41.9; H, 2.75; N, 9.8%); [{Ru(C₇H₈Cl₂)₂}]₂, reactants RuCl₃·3H₂O (0.32 g), EtOH (23 cm³) and cycloheptatriene (2 cm³) (Found: C, 31.6; H, 3.10. Calc. for C₁₄H₁₆Cl₄Ru₂: C, 31.8; H, 3.00%); [{Rh(cod)Cl}₂], reactants RhCl₃·3H₂O (0.33 g), EtOH-water (4:1, 23 cm³) and cyclooctadiene (2 cm³) (Found: C, 38.7; H, 5.00. Calc. for C₁₆H₂₄Cl₂Rh: C, 38.9; H, 4.90%); [Mo₆Cl₈][O₂CMe]₂Cl₂, good yields obtained when the acetic acid-anhydride mixture was preheated to 3.5 atm for 2 min prior to the addition of Mo₆Cl₁₂, reactants Mo₆Cl₁₂ (0.16 g), acetic acid (20 cm³) and acetic anhydride (0.5 cm³) (Found: C, 4.45; H, 0.70. Calc. for C₄H₆Cl₈Mo₆O₄: C, 4.60; H, 0.60%).

Synthesis of [RuL₂][PF₆]₂.—RuCl₃·3H₂O (0.17 g), L (Aldrich, 0.39 g) and MeOH (20 cm³) were introduced into the glass reaction vessel and stirred briefly. The pressure-control line was then attached to the vessel which was admitted to the microwave cavity through the port. A hold pressure of 10 atm with a 0.5 atm hysteresis was then set on the controller. The starting solution was deep red-brown. The reaction pressure increased to the cut-off pressure within 2 min of the start of microwave heating at 500 W. At this stage a grey material had precipitated from a pale green solution. The precipitate is believed to be the monosubstituted adduct [RuLCl₃]. After 40 min only a trace of the grey material remained and the heating was stopped after 70 min by which time the solution was pale yellow.

The final solution was transferred to a Schlenk tube and filtered. A saturated solution of methanolic NH₄PF₆ was filtered into the product solution. Immediately a white crystalline solid precipitated. The solid was collected by filtration and washed with MeOH and Et₂O prior to being dried *in vacuo*.

Yield: 0.46 g (96%) (Found: C, 19.20; H, 3.30. Calc. for $C_{12}H_{24}F_{12}P_2RuS_6$: C, 19.15; H, 3.20%).

Acknowledgements

Johnson-Matthey plc are thanked for the generous loan of $RuCl_3 \cdot 3H_2O$ and $RhCl_3 \cdot 3H_2O$, Cookson plc, the Air Force Office of Scientific Research and the SERC are thanked for their financial support.

References

- 1 D. M. P. Mingos and D. R. Baghurst, *Chem. Soc. Rev.*, 1991, **20**, 1.
- 2 R. J. Giguere, T. L. Bray, S. M. Duncan and G. Majetich, *Tetrahedron Lett.*, 1986, **27**, 4945; R. Gedye, F. Smith, K. Westaway, H. Ali, L. Balderisa, L. Laberge and J. Rousell, *Tetrahedron Lett.*, 1986, **27**, 279.
- 3 D. R. Baghurst, D. M. P. Mingos and M. J. Watson, *J. Organomet. Chem.*, 1989, **368**, C43.
- 4 D. L. Greene and D. M. P. Mingos, *Transition Met. Chem.*, 1991, **16**, 71.
- 5 M. Ali, S. P. Bond, S. A. Mbogo, W. R. McWhinnie and P. M. Watts, *J. Organomet. Chem.*, 1989, **371**, 11.
- 6 D. R. Baghurst, S. R. Cooper, D. L. Green, D. M. P. Mingos and S. M. Reynolds, *Polyhedron*, 1990, **9**, 893.
- 7 K. Chatakonda, M. L. H. Green, S. M. Reynolds and D. M. P. Mingos, *J. Chem. Soc., Chem. Commun.*, 1989, 1515.
- 8 A. B. Brignole and F. A. Cotton, *Inorg. Synth.*, 1972, **13**, 81.
- 9 D. Holste and H. Schafer, *Z. Anorg. Allg. Chem.*, 1972, **391**, 263.
- 10 S. R. Cooper, S. C. Rawle and T. J. Sewell, *Inorg. Chem.*, 1987, **26**, 3769.
- 11 R. A. Palmer and T. S. Piper, *Inorg. Chem.*, 1966, **5**, 864.
- 12 G. Winkhaus, *J. Organomet. Chem.*, 1967, **7**, 487.
- 13 D. A. Axelson, *Inorg. Synth.*, 1979, **19**, 218.
- 14 D. R. Baghurst, H. Fleischer, D. M. P. Mingos and T. R. Spalding, unpublished work.

Received 30th September 1991; Paper 1/05013C