

Synthesis and crystal structures of mononuclear half-sandwich complexes of Ni and Co containing Kläui's tripodal ligand, $[M\{\kappa^3-(\eta^5-C_5H_5)Co[P(=O)(OCH_3)_2]_3\}(\kappa^2-NO_3)(L)]$ ($M = Ni$ or Co)

Munetaka Akita,* De-qiang Ma, Shiro Hikichi and Yoshihiko Moro-oka*

Research Laboratory of Resources Utilization, Tokyo Institute of Technology, 4259 Nagatsuta, Midori-ku, Yokohama 226-8503, Japan

Received 7th October 1998, Accepted 21st January 1999

Synthesis of $L_{OR}M-X$ -type 1 : 1 mononuclear adducts containing Kläui's tripodal ligands $\{L_{OR} = CpCo[P(=O)(OR)_2]_3\}$ was studied. Addition of NaL_{OMe} to an excess amount of $CoCl_2$ did not afford a mononuclear product but the dinuclear complex $[Co(\mu-L_{OMe})_2CoCl_2]$ **1**, which results from co-ordination of the two P=O oxygen atoms in the initially formed 1 : 2 adduct, $Co(L_{OMe})_2$, to a second molecule of $CoCl_2$. In contrast, similar reaction of nitrate salts $M(NO_3)_2 \cdot 6H_2O$ followed by crystallization from acetone produced 1 : 1 mononuclear complexes, $[ML_{OMe}(\kappa^2-NO_3)(Me_2CO)]$ $M = Ni$ **3** or Co **4**, with octahedral co-ordination geometry. Before crystallization from acetone the dinuclear adduct $[Ni(\mu-L_{OR})_2(\mu-NO_3)_2Ni(NO_3)]$ **2** was isolated from a reaction mixture and subsequent treatment with acetone gave the mononuclear product **3**. Thus, for synthesis of $L_{OR}M-X$ -type complexes, it is essential to use a potentially κ^2 -co-ordinating ligand (*e.g.* NO_3) in the presence of a donor (*e.g.* acetone). The labile acetone ligand in **3** is replaced by P- and N-donors to give the substituted products $[NiL_{OMe}(\kappa^2-NO_3)(L)]$ ($L = PPh_3$ **5a**, 2,5-dimethylpyridine **5b** or 3,5-diisopropylpyrazole **5c**) and $[NiL_{OMe}(\kappa^2-NO_3)(py)_3]NO_3$ **6**. Complexes **1**, **2b**, **2c**, **3**, **4**, **5a–5c**, **6**, and $[NiL_{OMe}(\kappa^2-NO_3)(MeOH)]$ were characterized by X-ray crystallography.

Introduction

A variety of tripodal ligands have been utilized in studies of the co-ordination chemistry of transition metal complexes and, among them, N_3 -donors such as hydrotris(pyrazolyl)borates (Tp^R)¹ and 1,4,7-triazacyclononanes ($tacn^R$)² are most frequently employed. In our laboratory the Tp^R ligands have been used for synthetic studies of dioxygen complexes, because they are anticipated to mimic the co-ordination environment created by the three facially arranged histidyl residues which are often found in the active sites in metalloproteins.³ In contrast, studies of O_3 -tripodal ligands are rather rare and Kläui's tripodal ligand $\{L_{OR} = (\eta^5-C_5H_5)Co[P(=O)(OR)_2]_3\}$, Chart 1; throughout this paper the structure shown in parentheses is used as the abbreviated form of the ligand;⁴ is a typical example.

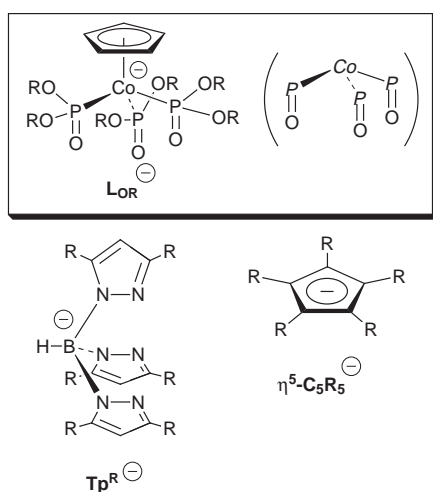

Chart 1

Both of the Tp^R and L_{OR} ligands are mononegative 6e donors isoelectronic with cyclopentadienyl ligands ($\eta^5-C_5R_5$), and comparative studies have been carried out in order to exam-

ine the effects of the atoms co-ordinated to the metal centers. However, difficulty in the synthesis of $LM-X$ -type half-sandwich complexes ($L = Tp^R$, $\eta^5-C_5R_5$ or L_{OR}) has often been reported. Simple mixing of the ligand and metal salts usually produces 1 : 2 adducts, ML_2 , instead of the desired $LM-X$ type complexes.⁵ The octahedral sandwich complexes, ML_2 , are usually inert with respect to subsequent replacement by other ligands and, therefore, their derivative chemistry would be extremely limited.

In the case of the Tp^R system the difficulty has been overcome by three methods and half-sandwich complexes (Tp^RM-X) are successfully prepared. The first method involves the use of bulky substituents (R) to prevent coupling with a second equivalent of the ligand leading to the undesired MTp^R_2 (method i). We reported that the 3,5-diisopropyl- and 3-*tert*-butyl-5-isopropyl-pyrazolyl derivatives, Tp^RM-X , served as versatile starting compounds for various co-ordination and organometallic compounds.³ It was also reported that $(\eta^5-C_5R_5)Fe-X$ was prepared successfully using bulky ligands such as pentaisopropylcyclopentadienyl ($R = i-Pr$).⁶ Recently we developed the synthetic method for Tp^RM-X -type complexes bearing less bulky R groups such as methyl (method ii). 1 : 1 Complexes may be obtained by addition of a Tp^R salt to an excess amount of metal salt.^{3g} Formation of MTp^R_2 , cannot be avoided completely. However, this procedure is useful if the Tp^RM-X complex can be purified at a latter stage of the reaction sequence. Another strategy to prevent the formation of MTp^R_2 is the use of salts with a bidentate ligand such as nitrate and carboxylate (method iii).^{3i,7} The resulting $Tp^RM(\kappa_2-X)$ should be less reactive toward a second equivalent of the Tp^R anion than the $Tp^RM(\kappa_1-X)$ species.

A considerable number of the $L_{OR}M(L)_n$ -type mononuclear half-sandwich complexes † are known for second row metals and

† Throughout this paper, when the nuclearity of the complexes is referred to, the cobalt atoms in L_{OR} are not included. For example, $[NiL_{OMe}(NO_3)(Me_2CO)]$ **3** is not a dinuclear but a 'mononuclear' complex.

early transition metals but few examples of first row, late transition metal complexes have been reported.⁸ Herein we report synthesis of half-sandwich complexes of nickel and cobalt containing the methoxy derivative of Kläui's ligand (L_{OMe}). We first attempted reaction of the isopropoxy ligand (L_{OiPr}) with MCl_2 (method i) but only intractable mixtures of products were obtained and isolation of the desired mononuclear complex was unsuccessful. Then we examined the above-mentioned procedures developed for the $Tp^R M$ system (methods ii and iii), and succeeded in synthesis of the desired mononuclear complexes. Results of ligand substitution reactions of the mononuclear complex will be also disclosed.

Results and discussion

Reaction of NaL_{OMe} with an excess amount of $CoCl_2$ giving a dinuclear complex containing the $(L_{OMe})_2Co$ unit

We attempted synthesis of a half-sandwich complex following method ii. Addition of a methanolic solution of NaL_{OMe} to an excess amount of $CoCl_2$ dissolved in MeOH resulted in a pink solution. Extraction with CH_2Cl_2 followed by crystallization from acetone afforded the blue product **1**. Its IR spectrum contained vibrations characteristic of the P=O functional group ($\nu_{P=O}$ 1136, $\delta_{P=O}$ 590 cm^{-1}) and its UV-VIS absorptions were observed at 562 and 671 nm in addition to the very intense UV absorptions in the range 200–350 nm due to the L_{OMe} chromophore. The result of elemental analysis was consistent with its formulation as $[(CoL_{OMe}Cl)_n]$. The product, however, was not the desired mononuclear complex but the dinuclear complex containing the $(L_{OMe})_2Co$ unit as revealed by X-ray crystallography.

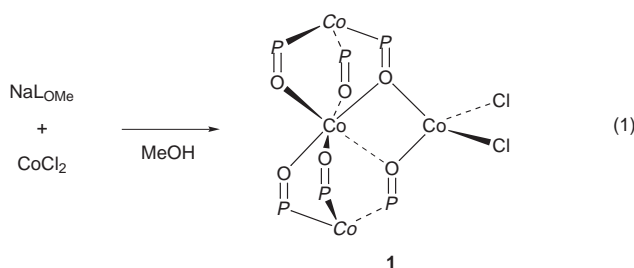

The molecular structure is shown in Fig. 1 and selected structural parameters are listed in Table 1. The dinuclear complex **1** contains the 1:2 adduct, $(L_{OMe})_2Co$, two P=O oxygen atoms of which are co-ordinated to $CoCl_2$. The virtually D_{3d} -symmetrical $(L_{OMe})_2Co$ part with the octahedral cobalt center (Co3) is similar to the previously reported 1:2 complex, $[Co(L_{OMe})_2]$, [Co–O 2.079–2.107(17) Å, O–Co–O 87.6–92.4°],⁹ though a slight distortion due to the co-ordination to the second Co (Co4) is evident. The Co–O and P=O distances associated with Co4 are longer than those not incorporated in the co-ordination to Co4 by *ca.* 0.15–0.18 and 0.03 Å, respectively. The Co4 center adopts a tetrahedral structure judging from the similar interligand angles [106.1–118.5(2)°] close to the interligand angle of an ideal tetrahedron (109.5°). Since NaL_{OMe} and $[Co(L_{OMe})_2]$ exhibited no absorption below 500 nm, the visible absorptions could be attributed to the d–d transitions of the tetrahedral cobalt moiety.

As can be seen from the molecular structure of complex **1**, it appears to be formed by addition of $CoCl_2$ to the initially generated 1:2 adduct, $(L_{OMe})_2Co$. The color change from pink to blue supports the initial formation of the six-co-ordinated species (pink), $[Co(L_{OMe})_2]$, which is converted into **1** (blue) during work-up. Analogous reaction of $NiCl_2 \cdot 6H_2O$ afforded $[Ni(L_{OMe})_2] \cdot 2NiCl_2$ judging from elemental analysis, but single crystals suitable for X-ray crystallography could not be obtained. These results indicate that the formation of the 1:2 adduct is inevitable even in the presence of an excess amount of

Table 1 Selected structural parameters for complex **1**^a

Co–P	2.142(2)–2.158(2)	Co4–O11	1.988(5)
Co–Cp	2.052(8)–2.082(8)	Co4–O41	1.996(5)
Co3–O11	2.180(5)	Co4–Cl1	2.213(3)
Co3–O21	2.014(4)	Co4–C12	2.213(3)
Co3–O31	2.034(5)	P=O11	1.509(4)
Co3–O41	2.187(4)	P=O41	1.512(4)
Co3–O51	2.018(5)	P=O	1.474–1.483(5)
Co3–O61	2.008(5)	P–O(Me)	1.551–1.602(9)
P–Co–P	91.02–92.48(8)	Cl1–Co4–O41	106.1(2)
O11–Co3–O21	92.9(2)	Cl2–Co4–O11	108.4(2)
O11–Co3–O31	82.3(2)	Cl2–Co4–O41	120.5(2)
O11–Co3–O41	79.6(2)	O11–Co4–O41	89.1(2)
O11–Co3–O51	93.6(2)	Co–P=O	118.5–120.7(2)
O21–Co3–O31	94.2(2)	Co–P–OMe	105.3–110.7(3)
O21–Co3–O51	89.1(2)	MeO–P=O	107.2–109.9(4)
O21–Co3–O61	93.8(2)	MeO–P–OMe	99.9–102.6(5)
O31–Co3–O41	94.7(2)	Co3–O–P	122.4–130.9(3)
O31–Co3–O61	90.0(2)	Co3–O11–Co4	95.8(2)
O41–Co3–O51	81.4(2)	Co3–O41–Co4	95.4(2)
O41–Co3–O61	95.0(2)	Co4–O11–P1	142.6(3)
O51–Co3–O61	93.8(2)	Co4–O41–P4	138.8(3)
Cl1–Co4–Cl2	112.7(1)	P–O–C	119.9–136.3(8)
Cl1–Co4–O11	118.5(2)		

^a Bond lengths in Å and bond angles in °.

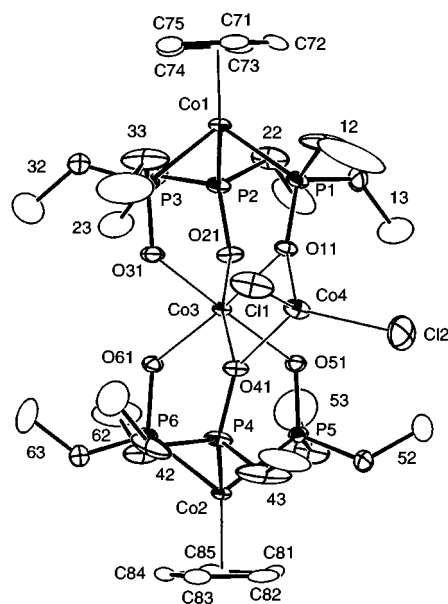

Fig. 1 Molecular structure of complex **1** drawn at the 30% probability level. Labels without atom names are for the methoxy groups.

MCl_2 . The highly co-ordinatively unsaturated 1:1 intermediate, $L_{OR}M-Cl$, is susceptible to further reaction with a second equivalent of the L_{OR} anion and even dimerization leading to $L_{OR}M(\mu-X)_2ML_{OR}$ is not observed. This result is in marked contrast to the Tp^{iPr} system which gives mononuclear tetrahedral halide complexes $Tp^{iPr}M-X$.³ Thus method ii turned out to be not effective for synthesis of the mononuclear L_{OR} complex and we moved to method iii.

Reaction of NaL_{OMe} with an excess amount of $M(NO_3)_2$ giving mononuclear half-sandwich complexes

(i) Formation of a dinuclear $\mu-NO_3$ complex in MeOH. Similar reaction of $M(NO_3)_2 \cdot 6H_2O$ containing the potentially κ^2 -co-ordinating nitrate ligand afforded different types of products. Addition of the L_{OR} anions (R = Me, Et or *i*-Pr) to an excess amount of $Ni(NO_3)_2 \cdot 6H_2O$ (under essentially the same reaction conditions as those of the formation of complex **1** discussed above) afforded green prisms **2** after crystallization from CH_2Cl_2 . However the products **2** were not desired mononuclear

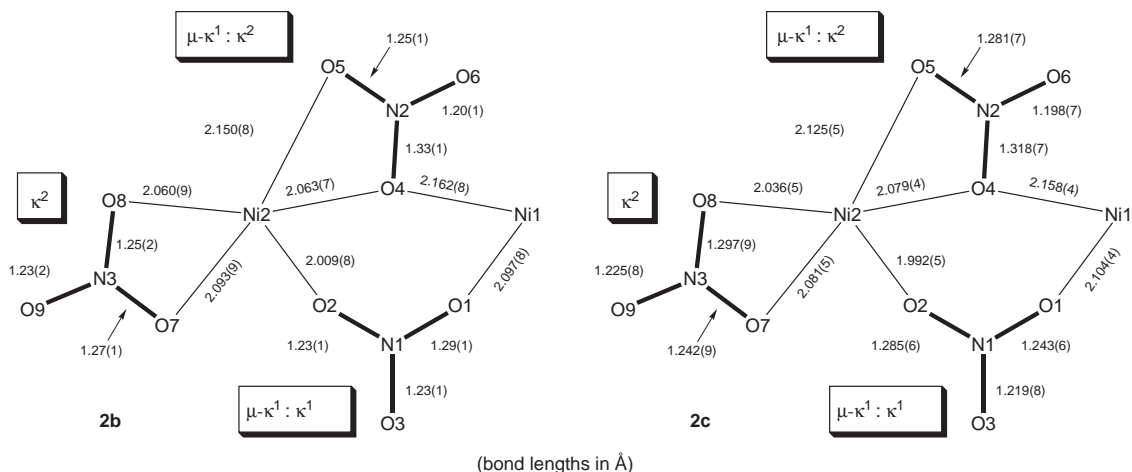
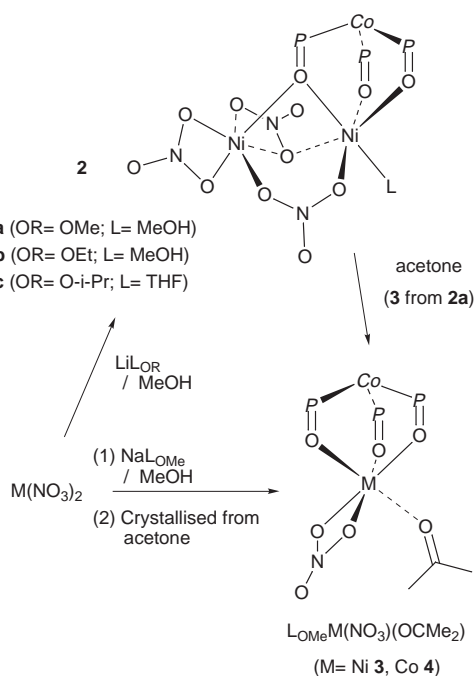

Chart 2 Bond lengths/Å of the core structures of complexes **2b** and **2c**.



complexes but again dinuclear complexes (Scheme 1). Reaction of LiL_{OEt} (in MeOH) and $\text{LiL}_{\text{O}i\text{Pr}}$ (in THF) with $\text{Ni}(\text{NO}_3)_2$ gave the dinuclear complexes **2a** ($L = \text{MeOH}$) and **2c** ($L = \text{THF}$), respectively, which were characterized by X-ray crystallography (Fig. 2 and Table 1).[‡]

The core structures of complexes **2b** and **2c** are essentially the same as compared in Chart 2. In the case of the L_{OMe} complex **2a** a mixture of products containing the dinuclear complex **2a** as the dominant component was obtained as judged by its UV-VIS spectrum but repeated recrystallization from CH_2Cl_2 led to isolation of a pure sample of the mononuclear complex $[\text{NiL}_{\text{OMe}}(\text{NO}_3)(\text{MeOH})]$ which was also characterized by X-ray crystallography. The different results for the L_{OR} ($R = \text{Et}$ or $i\text{-Pr}$) and L_{OMe} systems is due to the different solubilities of the complexes. Although single crystals of the L_{OEt} and $\text{L}_{\text{O}i\text{Pr}}$ complexes were obtained after simple crystallization, repeated recrystallization was needed for purification of the less soluble L_{OMe} complex and during the purification procedure the dinuclear core was broken to give the mononuclear complex.

In this case, however, it should be noted that the structures of

[‡] The numbering scheme for the core part of complex **2c** is the same as that of **2b**, and that for **4** is the same as that of **3** except for the metal atoms.

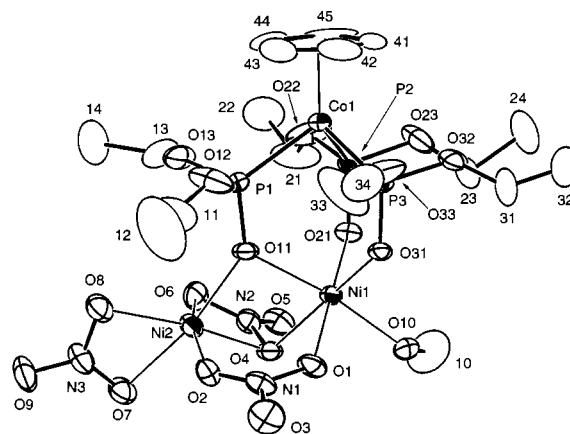

Fig. 2 Molecular structure of complex **2b** drawn at the 30% probability level. Labels without atom names are for the carbon atoms.

complexes **2b** and **2c** did not contain the 1:2 adduct unit, $[\text{Ni}(\text{L}_{\text{OMe}})_2]$, as found for the chloride complex **1** (see above). The nitrate complex **2** can be formulated as an adduct of $\text{Ni}(\text{NO}_3)_2$ to the mononuclear species, $\text{L}_{\text{OR}}\text{Ni}(\text{NO}_3)$, which is further solvated by MeOH or THF. Each nickel center adopts octahedral co-ordination geometry associated with the L_{OMe} and three NO_3 ligands, and the missing sixth co-ordination site of Ni1 is occupied by the methanol or THF solvate. It is notable that the three nitrate ligands interact with the two nickel centers in three different fashions.^{7a-i} Two of them bridge the two metal centers in the unusual $\mu\text{-}\kappa^1(\text{Ni}1) : \kappa^1(\text{Ni}2)$ and $\mu\text{-}\kappa^1(\text{Ni}1) : \kappa^2(\text{Ni}2)$ modes and the third nitrate acts as a chelating ligand toward Ni2. Complexes **2** are unique, containing three different co-ordination modes of the NO_3 ligand in one molecule (Chart 2). The $\mu\text{-}\kappa^1 : \kappa^1\text{-NO}_3$ ligand bridges the two metal centers in a virtually symmetrical manner. The $\mu\text{-}\kappa^1 : \kappa^2\text{-NO}_3$ ligand⁷ⁱ is slightly distorted from a symmetrical structure and the Ni2–O5 and N2–O4 distances are the longest of the Ni–O and N–O distances in the molecule, respectively. The chelating $\kappa^2\text{-NO}_3$ ligand interacts with Ni2 in a symmetrical manner.

(ii) Synthesis of mononuclear complexes, $[\text{ML}_{\text{OMe}}(\kappa^2\text{-NO}_3)(\text{Me}_2\text{CO})]$ ($M = \text{Ni}$ or Co). When the crystallization solvent for the reaction between NaL_{OMe} and $\text{Ni}(\text{NO}_3)_2 \cdot 6\text{H}_2\text{O}$ was changed from the non-co-ordinating CH_2Cl_2 to co-ordinating acetone, a green product **3** was isolated and characterized as a desired mononuclear complex by X-ray crystallography. Similar reaction between NaL_{OMe} and $\text{Co}(\text{NO}_3)_2 \cdot 6\text{H}_2\text{O}$ afforded the red-orange product **4**. Since the cell parameters for **3** and **4** are essentially the same (see Table 4) they are isostructural. In Fig. 3 the molecular structure of the nickel complex **3** is shown

Table 2 Selected structural parameters for complexes **2b** and **2c**^a

	2b	2c
Ni1–O11	2.074(7)	2.080(4)
Ni1–O21	1.986(8)	1.984(4)
Ni1–O31	2.003(7)	1.962(4)
Ni1–O (solvent)	2.040(8)	2.056(4)
Ni2–O11	2.033(8)	2.018(4)
N–O	1.20–1.33(2)	1.198–1.318(9)
Co–P	2.164–2.174(4)	2.171–2.175(2)
Co–Cp	2.05–2.09(2)	2.062–2.096(9)
P=O	1.487–1.521(8)	1.513–1.545(4)
P–OMe	1.54–1.60(1)	1.581–1.591(4)
O–Ni1–O	87.4–95.8(3)	82.5–98.1(2)
O2–Ni2–O4	100.5(3)	102.9(2)
O2–Ni2–O7	90.7(4)	89.9(2)
O2–Ni2–O8	91.1(4)	92.3(2)
O2–Ni2–O11	93.0(3)	88.9(2)
O4–Ni2–O5	62.1(3)	62.1(2)
O4–Ni2–O7	104.2(3)	100.6(2)
O4–Ni2–O11	84.4(3)	87.2(2)
O5–Ni2–O7	88.4(3)	89.7(2)
O5–Ni2–O8	104.6(3)	101.1(2)
O5–Ni2–O11	91.0(3)	93.5(2)
O7–Ni2–O8	62.2(4)	62.4(2)
O8–Ni2–O11	108.2(3)	110.0(2)
P–Co–P	91.5–94.7(1)	91.64–95.07(6)
Co–P=O	118.1–118.9(3)	116.9–119.0(2)
Co–P–OMe	107.6–113.9(7)	106.2–115.6(2)
O–P–OMe	107.0–109.0(5)	106.9–110.5(2)
MeO–P–OMe	97.7–99.8(9)	99.2–106.9(2)
Ni1–O1–N1	132.4(7)	130.6(3)
Ni2–O2–N1	124.8(7)	122.8(4)
Ni1–O4–Ni2	91.2(3)	89.4(2)
Ni1–O10–C10	123(1)	—
Ni1–O11–Ni2	94.6(3)	93.3(2)
O–N–O	115.1–124.6(10)	113.2–125.4(8)

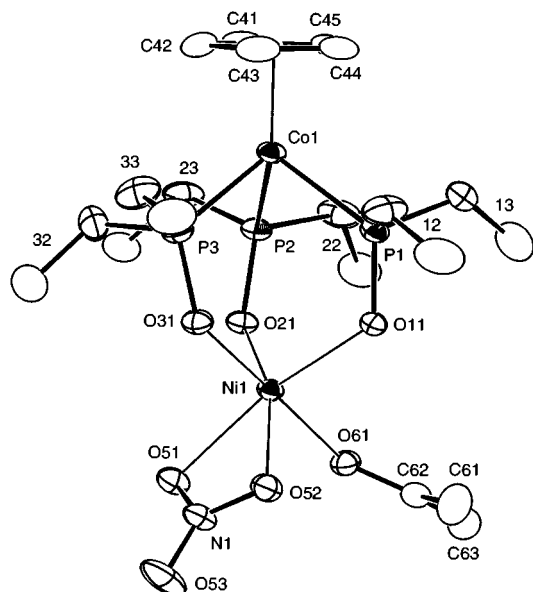
^a Bond lengths in Å and bond angles in °.**Fig. 3** Molecular structure of complex **3**. Details as in Fig. 1.

and selected structural parameters are listed in Table 3. The products **3** and **4** are mononuclear octahedral complexes coordinated by the κ^3 - L_{OMe} ligand, κ^2 -nitrate anion and acetone solvate. The three P=O oxygen atoms lie almost equidistant from the metal centers [Ni1 (**3**), Co2 (**4**)] indicating that the L_{OMe} ligand is symmetrically co-ordinated to them. The inter-ligand angles formed by the *cis* ligands except those associated with the chelating NO_3 ligand are close to the right angle, but the P–M–O (NO_2) angles ($\approx 160^\circ$) are considerably smaller than

the P–M–O (acetone) ($\approx 179^\circ$) due to the chelating NO_3 ligand. The M–O (acetone) lengths are shorter than the M–O (NO_3) by 0.02–0.03 Å.

The IR spectra of complexes **3** and **4** contain the strong absorptions associated with the L_{OMe} ligand ($\nu_{P=O}$ and δ_{P-O}) but the $\nu_{C=O}$ vibration of the acetone solvate cannot be located. In the UV–VIS spectra d–d transitions dependent on the solvent appear around 700 (**3**) and 500–600 nm (**4**) in addition to the strong absorptions due to the L_{OMe} moiety (<350 nm). The variable d–d transitions should be attributed to solvolysis of the acetone solvate as will be discussed below.

Crystallization solvents are the only difference in the reaction conditions for formation of the dinuclear product **2** (from CH_2Cl_2) and the mononuclear product **3** (from acetone) from NaL_{OMe} and $Ni(NO_3)_2$. This suggested that acetone (a co-ordinating solvent) might remove the nickel atom (Ni2 in **2b**) not co-ordinated by the L_{OMe} ligand in **3**. As was expected, treatment of **2** with acetone gave **3** quantitatively. Therefore it is concluded that reaction of NaL_{OMe} and $Ni(NO_3)_2$ in MeOH initially produces the dinuclear product **2**, which is converted into **3** after removal of the $Ni(NO_3)_2$ moiety by the action of the co-ordinating solvent and co-ordination to the resulting vacant site by the same solvent.

Thus synthesis of mononuclear complexes containing Kläui's ligand has been realized by the use of a chelating anion (NO_3) as well as a co-ordinating solvent (acetone), which prevents the formation of the undesirable sandwich complex, $[M(L_{OR})_2]$. A κ^2 -chelating ligand, however, is not always effective. Similar reaction of acetate salts of Ni and Co gave insoluble products and, therefore, an appropriate combination should be chosen.

Ligand substitution reactions of the complex $[NiL_{OMe}(\kappa^2-NO_3)(Me_2CO)]$ **3**

Co-ordinating solvents such as acetone in complexes **3** and **4** are known to be labile and, therefore, the complexes are expected to be converted into various derivatives. As a typical example, the nickel complex **3** was subjected to ligand substitution reaction with PPh_3 and N-donors (Scheme 2). Addition of

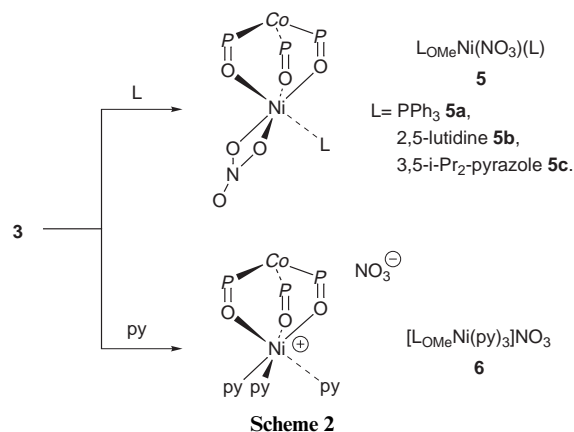

PPh_3 to a CH_2Cl_2 solution of **3** caused an immediate change from green to dark green and the deep green product **5a** was isolated. The reaction of pyridine derivatives were found to be dependent on the substituents on the ring. Pyridine caused ionization of the nitrate ligand to give the cationic tripyridine substituted complex **6**. Even a 1:1 reaction afforded the 1:3 adduct **6** as a sole product in low yield and no evidence for $[NiL_{OMe}(NO_3)(py)]$ was obtained. Introduction of methyl substituents, however, changed the reaction course. Whereas the highly sterically congested 2,6-dimethylpyridine left **3** unaffected, 2,5-dimethylpyridine bearing only one *ortho*-methyl substituent afforded the 1:1 adduct **5b**. 3,5-diisopropylpyrazole also afforded the 1:1 adduct **5c**.

Table 3 Selected structural parameters for L_{OMe}M(L)₃ **3-6**^a

M(L) ₃	3 Ni(NO ₃)(Me ₂ CO)	4 Co(NO ₃)(Me ₂ CO)	5a Ni(NO ₃)(PPh ₃)	5b Ni(NO ₃)(NC ₅ H ₃ Me ₂ -2,5)	5c Ni(NO ₃)(N ₂ C ₃ H ₂ Pr ⁱ -3,5)	6 Ni ⁺ (py) ₃ (molecule 1)	Ni ⁺ (py) ₃ (molecule 2)	[NiL _{OMe} (NO ₃)(MeOH)]
Co1-P	2.161-2.163(1)	2.150-2.168(2)	2.160-2.176(2)	2.164-2.171(2)	2.155-2.160(2)	2.156-2.167(3)	2.156-2.172(3)	2.093-2.207(2)
Co1-Cp	2.071-2.091(6)	2.08-2.11(1)	2.085-2.105(8)	2.04-2.064(10)	2.066-2.085(9)	2.05-2.07(2)	2.068-2.113(10)	2.069-2.089(5)
P-OMe	1.582-1.632(4)	1.568-1.627(8)	1.596-1.609(6)	1.566-1.607(6)	1.547-1.597(7)	1.594-1.609(7)	1.586-1.604(8)	1.455-1.598(5)
P=O	1.504-1.512(4)	1.504-1.506(6)	1.489-1.515(5)	1.498-1.502(4)	1.497-1.505(4)	1.490-1.503(8)	1.486-1.500(6)	1.520-1.599(5)
M-O11	2.002(4)	2.037(6)	2.017(4)	2.011(4)	2.023(4)	2.040(7)	2.071(7)	1.982(2)
M-O21	1.997(3)	2.038(4)	2.028(5)	2.023(3)	2.023(4)	2.091(5)	2.076(4)	2.130(5)
M-O31	2.005(3)	2.035(4)	2.059(6)	2.057(4)	2.027(4)	2.037(6)	2.016(5)	2.006(3)
M-L1 (L1)	2.107(4) (O51)	2.151(6) (O51)	2.174(5) (O51)	2.136(5) (O51)	2.132(3) (O51)	2.122(9) (N1a)	2.140(9) (N1b)	2.094(3) (O51)
M-L2 (L2)	2.132(3) (O52)	2.163(5) (O52)	2.095(5) (O52)	2.132(4) (O52)	2.133(4) (O52)	2.138(6) (N2a)	2.117(5) (N2b)	2.112(3) (O52)
M-L3 (L3)	2.084(3) (O61)	2.123(4) (O61)	2.456(2) (P1)	2.118(4) (N2)	2.041(4) (N61)	2.104(8) (N3a)	2.083(7) (N3b)	2.079(3) (O61)
N1-O51	1.263(5)	1.257(8)	1.274(9)	1.271(7)	1.273(6)	1.10(3)	1.13(2)	1.248(7)
N1-O52	1.259(6)	1.271(9)	1.272(7)	1.268(7)	1.267(5)	1.20(1)	1.16(3)	1.268(5)
N1-O53	1.229(7)	1.24(1)	1.23(1)	1.215(9)	1.215(6)	1.06(2)	1.10(2)	1.229(6)
O61-C61	1.228(5)	1.237(8)	—	—	—	—	—	1.421(6)
P1-Co1-P2	90.95(5)	91.05(8)	93.75(7)	91.24(5)	89.23(6)	91.3(1)	91.65(9)	89.46(6)
P1-Co1-P3	92.73(5)	93.12(9)	87.10(7)	90.72(6)	90.07(6)	91.53(9)	91.73(8)	95.57(6)
P2-Co1-P3	87.82(5)	88.63(8)	90.23(7)	88.74(7)	90.46(7)	90.5(1)	89.8(1)	91.85(5)
O11-M-O21	94.5(1)	92.8(2)	92.2(2)	92.6(2)	93.7(2)	87.2(2)	86.8(2)	87.3(2)
O11-M-O31	91.9(1)	91.9(2)	90.9(2)	89.0(2)	92.2(1)	91.7(3)	90.0(3)	93.3(1)
O21-M-O31	93.4(1)	92.7(2)	90.8(2)	90.8(1)	89.9(2)	92.3(2)	93.0(2)	95.9(2)
L1-M-L2	60.7(1)	59.5(2)	60.8(2)	60.6(2)	60.6(1)	98.7(3)	98.9(3)	61.1(2)
L1-M-L3	90.3(1)	92.3(2)	84.9(2)	93.8(2)	88.5(1)	91.5(3)	92.6(3)	87.2(1)
L2-M-L3	91.1(1)	90.2(2)	93.6(2)	88.5(2)	91.1(1)	91.8(3)	91.6(2)	87.9(1)
O11-M1-L1	165.3(1)	166.0(2)	157.5(2)	164.1(2)	162.4(1)	174.5(2)	172.5(2)	163.5(2)
O12-M1-L2	160.7(1)	160.5(2)	170.6(2)	163.6(2)	164.5(2)	173.3(3)	174.2(3)	168.0(1)
O13-M1-L3	179.4(1)	178.6(2)	169.1(1)	174.8(1)	176.6(2)	177.3(3)	178.7(3)	176.4(1)

^a Bond lengths in Å and bond angles in °.

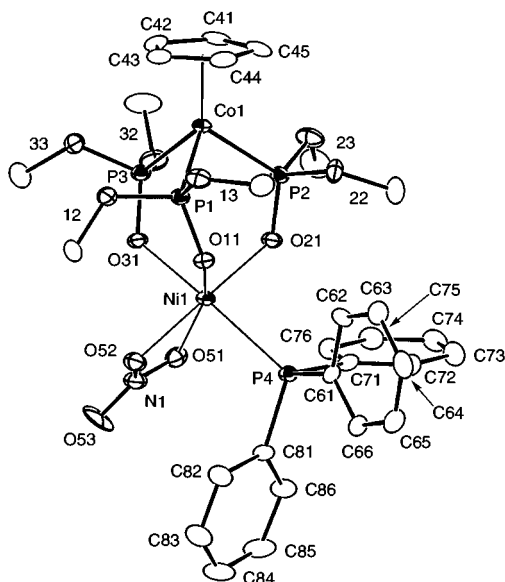

Fig. 4 Molecular structure of complex 5a. Details as in Fig. 1.

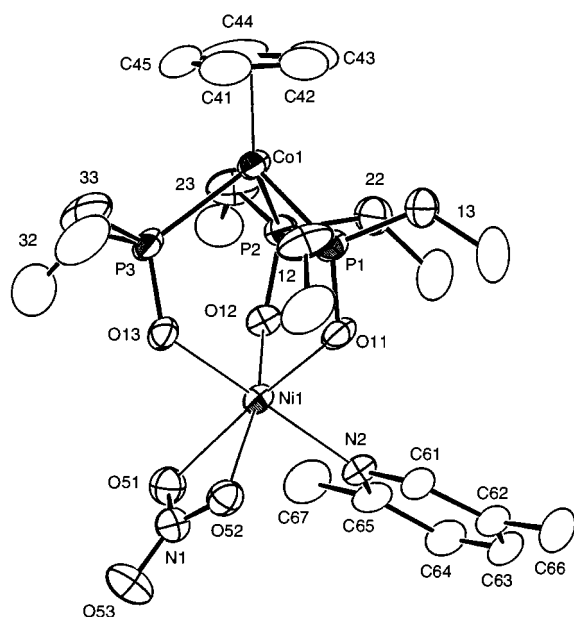

Fig. 5 Molecular structure of complex 5b. Details as in Fig. 1.

The structures of complexes **5a–5c** and **6** were determined by X-ray crystallography; corresponding ORTEP drawings of **5a–5c** and **6** (molecule 1) are shown in Figs. 4–7, and the structural parameters are compared in Table 3. A unit cell of **6** contains two independent molecules with essentially the same geometry.

The 1:1 adducts **5** result from simple substitution of the acetone ligand in **3** and the structural parameters are similar to those of **3** with the octahedral nickel center (Table 3). It is notable that, in **5c**, the short O51...N62 distance [2.878(6) Å] as well as the orientation of the pyrazole ring indicates the presence of a hydrogen-bonding interaction, which is also supported by the rather broad N–H vibration at 3353 cm⁻¹.

The cationic part of complex **6** adopts a virtual C_{3v}-symmetrical structure with octahedral co-ordination of the nickel center. The N–O vibration is observed at 1364 cm⁻¹ but it is impossible to differentiate the non-co-ordinated NO₃ anion from the κ²-bonded NO₃ ligand in the neutral complexes by the IR data.

These results indicate that the labile acetone adduct **3** serves as a versatile precursor for the mononuclear L_{OMe}Ni(NO₃)(L)- and L_{OMe}Ni(L)₃-type complexes containing Kläui's ligand.

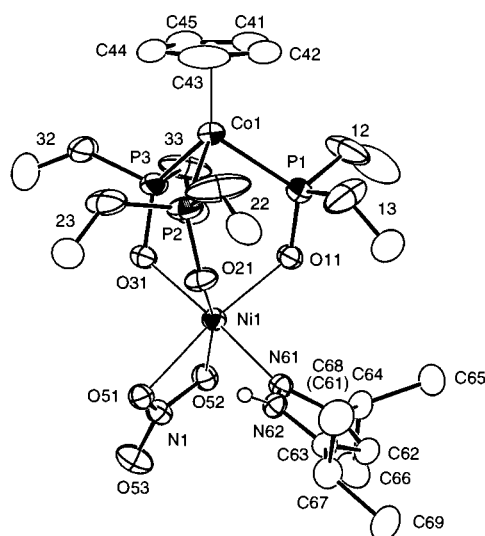

Fig. 6 Molecular structure of complex 5c. Details as in Fig. 1.

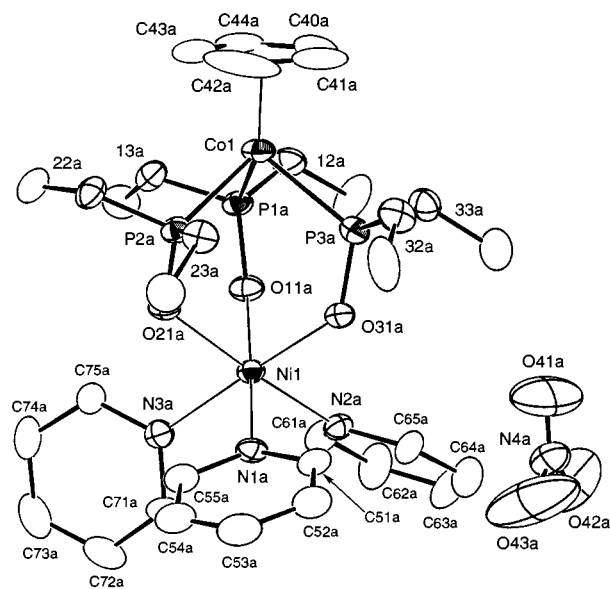

Fig. 7 Molecular structure of complex **6** (molecule 1). Details as in Fig. 1.

However it should be noted that the UV–VIS spectra of **5** are dependent on the solvent as observed for **3** (see above). When the spectra of **5a–5c** are recorded in CH₂Cl₂ the shapes of the d–d transitions are definitely different from each other indicating that the structures determined by X-ray crystallography are retained in CH₂Cl₂ solutions. In contrast, UV–VIS spectra of [NiL_{OMe}(NO₃)(L)] **3** and **5a–5c** observed in MeOH are essentially identical irrespective of L. This result suggests that the ligand L may be dissociated in MeOH. In accord with this observation a UV–VIS spectrum (in CH₂Cl₂) of a sample obtained by dissolution of **3** in MeOH followed by evaporation of the volatiles is identical to that of [NiL_{OMe}(NO₃)(MeOH)].

Conclusion

The present study reveals that selective synthesis of mononuclear complexes containing Kläui's ligand, [ML_{OMe}(κ²-NO₃)], is realized by adopting a combination of a metal salt with a potentially κ²-co-ordinating anion (NO₃) and a co-ordinating solvent (acetone). Through this strategy analogous to that used for the synthesis of mononuclear Tp^RM–X-type complexes (method iii; see Introduction), the formation of the undesirable 1:2 adducts, [M(L_{OR})₂], is prevented. Although the

products are not co-ordinatively unsaturated five-co-ordinated species as observed for $[\text{MTP}^{\text{R}}(\kappa^2\text{-NO}_3)]^{7a-f}$ but the fully co-ordinated octahedral species with the acetone solvate, the labile acetone ligand and even the chelating nitrate ligand can be replaced by other donor ligands.

The present work should trigger development of a new field of co-ordination chemistry and contribute to a comparative study with the Tp^{R} and $\eta^5\text{-C}_5\text{R}_5$ complexes. Functionalization of the mononuclear $\text{L}_{\text{OR}}\text{M}$ complexes is now under study and the results will be reported in due course.

Experimental

General methods

All manipulations were carried out under an inert atmosphere by using standard Schlenk techniques. Methanol $[\text{Mg}(\text{OMe})_2]$, acetone (KMnO_4 -molecular sieves), CH_2Cl_2 (P_4O_{10}) and diethyl ether (Na-K/benzophenone) were treated with appropriate drying agents, distilled, and stored under argon. The IR and UV-VIS spectra were obtained on a JASCO FT/IR 5300 and a Shimadzu UV-260 spectrometer, respectively. The compound NaL_{OMe} was prepared by a modified method, $[\text{CoCpI}_2(\text{CO}) + \text{P}(\text{OMe})_3 + \text{NaI}]$, according to the synthesis of the $[\text{CoCp}\{\text{P}(\text{O})(\text{OMe})(\text{OR})\}_3]$ derivative,¹¹ and LiL_{OEt} and LiL_{OIPr} were prepared following the reported methods.¹²

Preparations

$[\text{Co}_2(\text{L}_{\text{OMe}})_2\text{Cl}_2]$ 1. A methanolic solution (10 mL) of NaL_{OMe} (197 mg, 0.400 mmol) was added to CoCl_2 (160 mg, 0.551 mmol) dissolved in MeOH (10 mL) over a period of 2 h at room temperature. The resulting pink mixture was further stirred for 30 min at the same temperature. Then the volatiles were removed under reduced pressure and the products extracted with CH_2Cl_2 and filtered through a Celite pad. Crystallization from acetone gave complex **1** as blue needles (94 mg, 0.086 mmol, 43% yield). UV-VIS ($\lambda_{\text{max}}/\text{nm}$, $\epsilon/\text{M}^{-1}\text{cm}^{-1}$; in CH_2Cl_2): 243 (1.79×10^5), 336 (2.5×10^4), 862 (821) and 671 (1.10×10^3). IR (cm^{-1} ; KBr): 2948w, 2840w, 1458w, 1426w, 1263w, 1136s, 1032s, 1000s, 833m, 774s, 725s and 590s (Found: C, 24.33; H, 4.31; Cl, 6.26. Calc. for $\text{C}_{11}\text{H}_{23}\text{ClCo}_2\text{O}_9\text{P}_3$: C, 24.22; H, 4.25; Cl, 6.50%).

$[\text{Ni}(\text{L}_{\text{OMe}})_2] \cdot 2\text{NiCl}_2$. To a methanolic solution (5 mL) of $\text{NiCl}_2 \cdot 6\text{H}_2\text{O}$ (440 mg, 1.85 mmol) was added NaL_{OMe} (293 mg, 0.617 mmol) dissolved in MeOH (10 mL) over a period of 2 h at room temperature. Work-up as described for the synthesis of complex **1** gave $[\text{Ni}(\text{L}_{\text{OMe}})_2] \cdot 2\text{NiCl}_2$ as a green powder (328 mg, 0.269 mmol, 87% yield). UV-VIS ($\lambda_{\text{max}}/\text{nm}$, $\epsilon/\text{M}^{-1}\text{cm}^{-1}$; in CH_2Cl_2): 243 (5.87×10^4), 328 (1.75×10^4), 609 (13), 621 (14), 671 (19), 703 (20) and 834 (13). IR (cm^{-1} ; KBr): 2949m, 2841m, 1462m, 1427m, 1262m, 1180m, 1138s, 1034s, 991s, 833s, 774s, 728s and 585s (Found: C, 22.29; H, 4.22; Cl, 11.62. Calc. for $\text{C}_{22}\text{H}_{46}\text{Cl}_4\text{Co}_2\text{Ni}_3\text{O}_{18}\text{P}_6$: C, 21.65; H, 3.80; Cl, 12.27%).

$[\text{NiL}_{\text{OMe}}(\text{NO}_3)(\text{MeOH})]$. Attempted isolation of the dinuclear adduct **2a** was unsuccessful due to contamination from $[\text{NiL}_{\text{OMe}}(\text{NO}_3)(\text{MeOH})]$. The compound NaL_{OMe} (131 mg, 0.276 mmol) dissolved in MeOH (8 mL) was added to a methanolic solution (4 mL) of $\text{Ni}(\text{NO}_3)_2 \cdot 6\text{H}_2\text{O}$ (241 mg, 0.829 mmol) dropwise over a period of 0.5 h at r.t. and the mixture further stirred for 1.5 h at room temperature (r.t.). Then the volatiles were removed under reduced pressure and the products extracted with CH_2Cl_2 and filtered through a Celite pad. Addition of ether followed by cooling at -30°C gave $[\text{NiL}_{\text{OMe}}(\text{NO}_3)(\text{MeOH})]$ as green crystals (104 mg, 0.172 mmol, 62% yield). UV-VIS ($\lambda_{\text{max}}/\text{nm}$, $\epsilon/\text{M}^{-1}\text{cm}^{-1}$): (in methanol) 242 (2.89×10^4), 332 (3.76×10^3), 676 (4.8) and 740 (4.8); (in CH_2Cl_2) 243 (3.09×10^4), 333 (4.09×10^3), 690 (6.8) and 768 (8.7). IR (cm^{-1} ; KBr): 3417s, 2994m, 2949m, 2842m, 1769w, 1639s,

1458w, 1424w, 1385s, 1180w, 1136s, 1084w, 1001s, 833s, 774s, 728s and 591s (Found: C, 23.47; H, 4.59; N, 2.27. Calc. for $\text{C}_{12}\text{H}_{27}\text{CoNNiO}_{13}\text{P}_3$: C, 23.87; H, 4.51; N, 2.32%).

$[\text{Ni}_2\text{L}_{\text{OEt}}(\text{NO}_3)_3(\text{MeOH})]$ 2b. A methanolic solution (10 mL) of LiL_{OEt} (106 mg, 0.195 mmol) was added to $\text{Ni}(\text{NO}_3)_2 \cdot 6\text{H}_2\text{O}$ (160 mg, 0.551 mmol) over a period of 1.5 h at room temperature. The resulting green mixture was further stirred for 30 min at the same temperature. Work-up as described for complex **2a** followed by crystallization from CH_2Cl_2 gave **2b** as green prisms (142 mg, 0.163 mmol, 83% yield). UV-VIS ($\lambda_{\text{max}}/\text{nm}$, $\epsilon/\text{M}^{-1}\text{cm}^{-1}$): (in methanol) 243 (3.01×10^4), 334 (3.98×10^3), 677 (5.7) and 737 (6.2); (in CH_2Cl_2) 245 (2.58×10^4), 335 (3.23×10^3), 694 (9.4) and 766 (10.0). IR (cm^{-1} ; KBr): 2979m, 1385s, 1263m, 1130s, 1040s, 934s, 802m, 774m, 738m, 595s and 503w (Found: C, 25.44; H, 4.86; N, 4.28. Calc. for $\text{C}_{18}\text{H}_{39}\text{CoN}_3\text{Ni}_2\text{O}_{19}\text{P}_3$: C, 24.84; H, 4.51; N, 4.83%).

$[\text{Ni}_2\text{L}_{\text{OIPr}}(\text{NO}_3)_3(\text{THF})]$ 2c. A THF solution (20 mL) of LiL_{OIPr} (403 mg, 0.779 mmol) was added to $\text{Ni}(\text{NO}_3)_2 \cdot 6\text{H}_2\text{O}$ (678 mg, 2.34 mmol) over a period of 2 h at room temperature. Work-up as described for complex **2a** followed by crystallization from CH_2Cl_2 gave **2c** as green crystals (434 mg, 0.436 mmol, 56% yield). UV-VIS ($\lambda_{\text{max}}/\text{nm}$, $\epsilon/\text{M}^{-1}\text{cm}^{-1}$): (in methanol) 248 (2.72×10^4), 338 (3.27×10^3), 695 (7.0) and 781 (9.2); (in CH_2Cl_2) 248 (1.93×10^4), 337 (2.45×10^3), 675 (5.2) and 743 (9.2). IR (cm^{-1} ; KBr): 2978s, 2935w, 2872w, 1494m, 1384s, 1283w, 1146s, 1128s, 1108s, 979s, 943s, 874s, 829s, 753s, 724m and 588s (Found: C, 31.36; H, 6.11; N, 3.63. Calc. for $\text{C}_{27}\text{H}_{55}\text{CoN}_3\text{Ni}_2\text{O}_{19}\text{P}_3$: C, 32.59; H, 5.57; N, 4.22%).

$[\text{NiL}_{\text{OMe}}(\text{NO}_3)(\text{Me}_2\text{CO})]$ 3. A methanolic solution (10 mL) of NaL_{OMe} (227 mg, 0.478 mmol) was added to $\text{Ni}(\text{NO}_3)_2 \cdot 6\text{H}_2\text{O}$ (399 mg, 1.37 mmol) over a period of 2 h at room temperature. The resulting mixture was further stirred for 30 min at the same temperature. Work-up as described for complex **2a** followed by crystallization from acetone gave **3** as green crystals (221 mg, 0.352 mmol, 73% yield). UV-VIS ($\lambda_{\text{max}}/\text{nm}$, $\epsilon/\text{M}^{-1}\text{cm}^{-1}$): in CH_2Cl_2 243 (3.67×10^4), 336 (4.80×10^3), 700 (4.1) and 796 (5.3); in methanol 242 (2.96×10^4), 334 (3.68×10^3), 677 (1.76) and 749 (2.34). IR (cm^{-1} ; KBr): 3123w, 2949m, 2843m, 1763w, 1461w, 1385s, 1179w, 1130s, 1087m, 1033s, 997s, 832s, 774s, 753w, 726s, 589s and 475m (Found: C, 26.34; H, 4.60; N, 2.34. Calc. for $\text{C}_{14}\text{H}_{29}\text{CoNNiO}_{13}\text{P}_3$: C, 26.69; H, 4.64; N, 2.22%).

$[\text{CoL}_{\text{OMe}}(\text{NO}_3)(\text{Me}_2\text{CO})]$ 4. A methanolic solution (10 mL) of NaL_{OMe} (132 mg, 0.267 mmol) was added to $\text{Co}(\text{NO}_3)_2 \cdot 6\text{H}_2\text{O}$ (238 mg, 0.817 mmol) over a period of 2 h at room temperature. The resulting reddish brown mixture was further stirred for 30 min at the same temperature. Work-up as described for complex **2a** followed by crystallization from acetone-ether gave **4** as orange-red crystals (100 mg, 0.149 mmol, 56% yield). UV-VIS ($\lambda_{\text{max}}/\text{nm}$, $\epsilon/\text{M}^{-1}\text{cm}^{-1}$): (in CH_2Cl_2) 242 (3.1×10^4), 336 (4.3×10^3) and 583 (554); (in methanol) 240 (3.3×10^4), 334 (4.1×10^3) and 511 (16). IR (cm^{-1} ; KBr): 2994w, 2950m, 2844w, 1385s, 1340m, 1262w, 1179w, 1131s, 1034s, 1002s, 834w, 774s, 729s and 592s (Found: C, 26.29; H, 4.50; N, 2.37. Calc. for $\text{C}_{14}\text{H}_{29}\text{Co}_2\text{NO}_{13}\text{P}_3$: C, 26.68; H, 4.64; N, 2.22%).

$[\text{NiL}_{\text{OMe}}(\text{NO}_3)(\text{PPh}_3)]$ 5a. Upon addition of PPh_3 (66 mg, 0.250 mmol) to a CH_2Cl_2 solution (5 mL) of complex **3** (158 mg, 0.250 mmol) the solution changed to dark green. After the mixture was stirred overnight the volume was reduced to 1/3 by evaporation under reduced pressure and the product crystallized at -30°C after addition of ether. Complex **5a** was obtained as green crystals (167 mg, 0.200 mmol, 80% yield). UV-VIS ($\lambda_{\text{max}}/\text{nm}$, $\epsilon/\text{M}^{-1}\text{cm}^{-1}$): (in CH_2Cl_2) 242 (3.24×10^4), 334 (3.28×10^3), 690 (6.0) and 767 (6.40); (in MeOH) 242 (3.49×10^4), 334 (4.07×10^3), 667 (3.43) and 745 (3.84). IR

Table 4 Crystallographic data

	1 ·Me ₂ CO	2b ·2CH ₂ Cl ₂	2c ·CH ₂ Cl ₂ ·OEt ₂	3	4	5a	5b ·0.5Et ₂ O	5c ·CH ₂ Cl ₂	6	[NiL _{OMe} (NO ₃)- (MeOH)]
Formula	C ₂₅ H ₅₂ Cl ₂ Co ₄ - O ₁₉ P ₆	C ₂₀ H ₄₃ Cl ₄ CoN ₅ - Ni ₂ O ₁₉ P ₃	C ₃₂ H ₆₇ Cl ₂ CoN ₅ - Ni ₂ O ₂₀ P ₃	C ₁₄ H ₂₉ CoNNi- O ₁₃ P ₃	C ₁₄ H ₂₉ Co ₂ - NO ₁₃ P ₃	C ₂₉ H ₃₈ CoNNi- O ₁₂ P ₄	C ₂₀ H ₃₇ CoN ₂ - NiO _{12.5} P ₃	C ₂₁ H ₄₁ Cl ₂ CoN ₂ - NiO ₁₂ P ₃	C ₂₆ H ₃₈ CoN ₄ - NiO ₁₂ P ₃	C ₁₂ H ₂₇ CoNNi- O ₁₃ P ₃
Formula weight	1149.2	1040.6	1154.1	629.9	630.2	834.2	716.1	809.0	809.2	603.9
Crystal system	Tetragonal	Monoclinic	Monoclinic	Monoclinic	Monoclinic	Monoclinic	Triclinic	Monoclinic	Triclinic	Monoclinic
Space group	<i>P</i> 4 ₂ <i>c</i>	<i>P</i> 2 ₁ / <i>c</i>	<i>P</i> 2 ₁ / <i>n</i>	<i>P</i> 2 ₁ / <i>n</i>	<i>P</i> 2 ₁ / <i>n</i>	<i>P</i> 2 ₁	<i>P</i> 1	<i>P</i> 2 ₁ / <i>n</i>	<i>P</i> 1	<i>P</i> 2 ₁ / <i>c</i>
<i>a</i> /Å	28.89(2)	11.036(1)	12.454(2)	8.568(1)	8.567(2)	10.816(1)	11.583(4)	10.779(3)	17.747(4)	8.725(2)
<i>b</i> /Å	28.89(2)	18.035(3)	22.707(9)	33.045(5)	33.072(9)	13.081(2)	14.345(6)	13.748(3)	19.196(4)	16.65(2)
<i>c</i> /Å	10.616(5)	20.296(6)	17.326(2)	8.890(2)	8.99(1)	12.573(6)	10.002(3)	23.22(1)	12.167(4)	15.568(4)
<i>α</i> /°							106.54(3)		100.44(1)	
<i>β</i> /°		94.577(5)	90.18(1)	102.378(4)	102.31(5)	104.929(3)	108.50(2)	96.46(5)	102.09(1)	103.60(2)
<i>γ</i> /°							82.43(3)		117.18(1)	
<i>V</i> /Å ³	8857(7)	4026(1)	4900(2)	2458.4(6)	2487(2)	1718.7(7)	1509.3(10)	3419(2)	3418(1)	
<i>Z</i>	8	4	4	4	4	2	2	4	4	2210(1)
<i>D</i> _x /g cm ⁻³	1.72	1.72	1.56	1.70	1.68	1.61	1.58	1.57	1.57	1.81
<i>μ</i> /cm ⁻¹	18.8	17.9	13.8	17.0	15.9	12.8	13.9	13.9	12.4	18.8
<i>T</i> /°C	-60	-60	-60	-60	-60	-60	25	-60	-60	-60
Maximum 2 θ /°	54.2	55.0	55.0	55.1	50.0	55.0	50	55.1	55.3	55.1
Transmission factor	0.87-1.00	0.94-1.00	0.92-1.00	0.90-1.00	0.94-1.00	0.88-1.00	0.93-1.00	0.90-1.00	0.91-1.00	0.93-1.00
No. data collected	5133	6166	9714	5213	4571	3545	5637	6903	10293	4628
No. parameters refined	497	473	540	306	306	439	367	402	991	348
<i>R</i> 1	0.0446	0.0949	0.0908	0.0615	0.0939	0.0468	0.0470	0.0865	0.0768	0.0625
[<i>F</i> _o > 4 σ (<i>F</i> _o)]	(4237)	(5852)	(9173)	(4869)	(3689)	(3439)	(3838)	(6378)	(8662)	(4450)
<i>wR</i> 2	0.1381	0.2394	0.2777	0.1854	0.3089	0.1352	0.1617	0.2514	0.2090	0.1909
(all data)	(5089)	(6118)	(9712)	(5188)	(3868)	(3545)	(5304)	(6903)	(10293)	(4555)

(cm^{-1} ; KBr): 3061w, 2985w, 2945m, 2840w, 1479m, 1432m, 1385m, 1279m, 1134s, 1095m, 1024s, 980s, 844m, 774s, 729s, 613m, 587s and 503w (Found: C, 41.60; H, 4.50; N, 1.63. Calc. for $\text{C}_{29}\text{H}_{38}\text{CoNNiO}_{12}\text{P}_4$: C, 41.76; H, 4.59; N, 1.68%).

[NiL_{OMe}(NO₃)(NC₅H₃Me₂-2,5)] 5b. Addition of 2,5-dimethylpyridine (24 mg, 0.219 mmol) to a CH_2Cl_2 solution (5 mL) of complex **3** (138 mg, 0.219 mmol) caused an immediate change from yellow to green. After the mixture was stirred overnight, work-up as described for **5a** gave **5b** as green crystals (117 mg, 0.172 mmol, 78% yield). UV-VIS ($\lambda_{\text{max}}/\text{nm}$, $\epsilon/\text{M}^{-1}\text{cm}^{-1}$): (in CH_2Cl_2) 243 (3.43×10^4), 334 (4.36×10^3) and 687 (8.40); (in MeOH) 243 (3.94×10^4), 333 (4.85×10^3), 632 (4.9) and 737 (4.9). IR (cm^{-1} ; KBr): 2982w, 2947m(br), 2840w, 1613w, 1498w, 1477s, 1427w, 1385s, 1290s, 1134s, 1034s, 1002s, 838m, 774s, 727s, 627m, 596s and 475w (Found: C, 31.40; H, 4.92; N, 3.87. Calc. for $\text{C}_{18}\text{H}_{32}\text{CoN}_2\text{NiO}_{12}\text{P}_3$: C, 31.84; H, 4.75; N, 4.13%).

[NiL_{OMe}(NO₃)(N₂C₃H₂Prⁱ-3,5)] 5c. Addition of 3,5-diisopropylpyrazole (32 mg, 0.21 mmol) to a CH_2Cl_2 solution (5 mL) of complex **3** (133 mg, 0.210 mmol) caused an immediate change from yellow to green. After the mixture was stirred overnight, work-up as described for **5a** gave **5c** as green crystals (111 mg, 0.154 mmol, 73% yield). UV-VIS ($\lambda_{\text{max}}/\text{nm}$, $\epsilon/\text{M}^{-1}\text{cm}^{-1}$) (in CH_2Cl_2) 242 (3.66×10^4), 333 (4.71×10^3), 682 (7.95) and 755 (5.38); (in MeOH) 242 (2.98×10^4), 333 (3.84×10^3), 677 (3.05) and 742 (3.37). IR (cm^{-1} ; KBr): 3353m, 2948m, 2841w, 1570w, 1485s, 1385m, 1288s, 1181w, 1129s, 1025s, 838w, 777s, 726s, 594s and 487w (Found: C, 32.32; H, 5.38; N, 5.72. Calc. for $\text{C}_{20}\text{H}_{38}\text{CoN}_3\text{NiO}_{12}\text{P}_4$: C, 33.22; H, 5.30; N, 5.81%).

[NiL_{OMe}(py)₃]NO₃ 6. Addition of pyridine (61 mg, 0.769 mmol) to complex **3** (161 mg, 0.256 mmol) dissolved in 5 mL of CH_2Cl_2 caused a change to deep green. After the mixture was stirred overnight at ambient temperature, work-up as described for **5a** gave **6** (150 mg, 0.185 mmol, 72% yield) as green crystals. UV-VIS ($\lambda_{\text{max}}/\text{nm}$, $\epsilon/\text{M}^{-1}\text{cm}^{-1}$; in CH_2Cl_2): 244 (3.10×10^4), 334 (3.40×10^3) and 660 (5.8). IR (cm^{-1} ; KBr): 3113w, 2949m, 2843w, 1601m, 1445m, 1364m, 1132s, 1040s, 1009s, 841m, 772s, 727s and 583s (Found: C, 37.52; H, 4.85; N, 6.80. Calc. for $\text{C}_{26}\text{H}_{38}\text{CoN}_4\text{NiO}_{12}\text{P}_3$: C, 38.59; H, 4.73; N, 6.92%).

X-Ray crystallography

Single crystals of complexes **1** (acetone), **2b** (CH_2Cl_2), **2c** (CH_2Cl_2 -ether), **3** (acetone), **4** (acetone), **5a-5c** (CH_2Cl_2 -ether), **6** (CH_2Cl_2 -ether) and $[\text{NiL}_{\text{OMe}}(\text{NO}_3)(\text{MeOH})]$ (CH_2Cl_2 -ether) were obtained by recrystallization from the solvent systems shown in parentheses and mounted on glass fibers. Diffraction measurements of **1**, **2b**, **2c**, **3**, **4**, **5a**, **5c**, **6**, and $[\text{NiL}_{\text{OMe}}(\text{NO}_3)(\text{MeOH})]$ were made on a Rigaku RAXIS IV imaging plate area detector with Mo-K α radiation ($\lambda = 0.71069 \text{ \AA}$). In the reduction of data Lorentz-polarization corrections were made. Empirical absorption corrections were also made.¹³ Diffraction measurements of **5b** were made on a Rigaku AFC-5S four-circle diffractometer with Mo-K α radiation ($\lambda = 0.71069 \text{ \AA}$). The unit cell was determined and refined by a least-squares method using 20 independent reflections ($2\theta \approx 20^\circ$). Data were collected with an ω - 2θ scan technique. If $\sigma(F)/F$ was more than 0.1 a scan was repeated up to three times and the results were added to the first scan. Three standard reflections were monitored at every 150 measurements. In the reduction of data Lorentz-polarization corrections and an empirical absorption correction (ψ scan) were made. Crystallographic data and results of structure refinements are listed in Table 4.

The structural analysis was performed on an IRIS O2 computer using TEXSAN.¹⁴ Neutral scattering factors were obtained from the standard source.¹⁵ The structures were solved by a combination of the direct methods (SHELXS 86)¹⁶ and Fourier synthesis (DIRDIF).¹⁷ Least-squares refinements were

carried out using SHELXL 93¹⁸ (refined on F^2) linked to TEXSAN. Non-hydrogen atoms were refined with anisotropic thermal parameters. Except for complexes **2b** and $[\text{NiL}_{\text{OMe}}(\kappa^2\text{-NO}_3)(\text{MeOH})]$, all the methyl hydrogen atoms were refined using riding models and the other hydrogen atoms were fixed at the calculated positions (C-H 0.95 \AA) and not refined. The disordered OEt part in **2b** was refined taking into account the minor component C13A and the occupancy factors for C13 and C13A were adjusted to be 0.623 and 0.377, respectively. The disordered solvates of **2c** were refined isotropically. In $[\text{NiL}_{\text{OMe}}(\kappa^2\text{-NO}_3)(\text{MeOH})]$, the three phosphorus atoms and some of the oxygen atoms attached to them are disordered with respect to the threefold Ni-Co axis, and the minor components (A series; occupancy factor 0.467) were taken into account for the refinement.

CCDC reference number 186/1328.

Acknowledgements

We are grateful to the Ministry of Education, Science, Sports and Culture of the Japanese Government for financial support of this research (Grant-in-Aid for Specially Promoted Research 08102006). D. M. thanks the Kyoritsu International Foundation of Japan for generous support.

References

- 1 Reviews: S. Trofimenko, *Chem. Rev.*, 1993, **93**, 943; N. Kitajima and W. B. Tolman, *Prog. Inorg. Chem.*, 1995, **43**, 419; N. Kitajima and Y. Moro-oka, *Chem. Rev.*, 1994, **94**, 737.
- 2 Reviews: K. Wieghardt and P. Chaudhuri, *Prog. Inorg. Chem.*, 1988, **35**, 329; W. B. Tolman, *Acc. Chem. Res.*, 1997, **30**, 227. Leading references: J. R. Hartman, R. L. Radin, P. Chaudhuri, K. Pohl, K. Wieghardt, B. Nuber, J. Weiss, G. C. Papefthymiou, R. B. Frankel and S. J. Lippard, *J. Am. Chem. Soc.*, 1987, **109**, 7387; P. Chaudhuri, M. Winter, K. Wieghardt, S. Gehring, W. Haase, B. Nuber and J. Weiss, *Inorg. Chem.*, 1988, **27**, 1564; S. Drücke, K. Wieghardt, B. Nuber and J. Weiss, *Inorg. Chem.*, 1989, **28**, 1414; U. Bossek, T. Weyermüller, K. Wieghardt, J. Bonvoisin and J. J. Girerd, *J. Chem. Soc., Chem. Commun.*, 1989, 633; P. Chaudhuri, M. Winter, D. Védova, P. Fleischhauer, W. Haase, U. Flörke and H.-J. Haupt, *Inorg. Chem.*, 1991, **30**, 4777; R. Hotzelmann, K. Wieghardt, J. Enslin, H. Romstedt, P. Gütllich, E. Bill and H.-J. Haupt, *J. Am. Chem. Soc.*, 1992, **114**, 9470; R. Hotzelmann, K. Wieghardt, U. Flörke, H.-J. Haupt, D. C. Weatherburn, J. Bonvoisin, G. Blondin and J.-J. Girerd, *J. Am. Chem. Soc.*, 1992, **114**, 1681; L. Wang and T. C. Flood, *J. Am. Chem. Soc.*, 1992, **114**, 3169; T. N. Margulis and L. J. Zompa, *Inorg. Chim. Acta*, 1992, **201**, 61; D. Hanke, K. Wieghardt, B. Nuber, R.-S. Lu, R. K. McMullan, T. F. Koetzle and B. Bau, *Inorg. Chem.*, 1993, **32**, 4300; F. Birkelbach, M. Winter, U. Flörke, H.-J. Haupt, C. Butzlaff, M. Lengen, E. Bill, A. X. Trautwein, K. Wieghardt and P. Chaudhuri, *Inorg. Chem.*, 1994, **33**, 3990; Y. Sasaki, K. Umakoshi, S. Kimura, C.-E. Oh, M. Yamazaki and T. Shibahara, *Chem. Lett.*, 1994, 1185; L. Wang, C. Wang, R. Bau and T. C. Flood, *Organometallics*, 1996, **15**, 491; S.-M. Yang, M. C.-W. Chan, K.-K. Cheung, C.-M. Che and S.-M. Peng, *Organometallics*, 1997, **16**, 2819; J. A. Halfen, S. Maharatra, E. C. Wilkinson, E. C. Kaderli, V. G. Young, Jr., L. Que, Jr., A. D. Zuberbühler and W. B. Tolman, *Science*, 1996, **271**, 1397; S. Maharatra, J. A. Halfen, E. C. Wilkinson, G. Pan, V. G. Young, Jr., C. J. Cramer, L. Que, Jr. and W. B. Tolman, *J. Am. Chem. Soc.*, 1996, **118**, 11555.
- 3 (a) M. Akita, K. Ohta, Y. Takahashi, S. Hikichi and Y. Moro-oka, *Organometallics*, 1997, **16**, 4121; (b) Y. Takahashi, M. Akita, S. Hikichi and Y. Moro-oka, *Inorg. Chem.*, 1998, **37**, 2614; (c) Y. Takahashi, M. Akita, S. Hikichi and Y. Moro-oka, *Organometallics*, 1998, **37**, 4884; (d) M. Akita, T. Miyaji, S. Hikichi and Y. Moro-oka, *Chem. Commun.*, 1998, 1005; (e) S. Hikichi, H. Komatsuzaki, N. Kitajima, M. Akita, M. Mukai, T. Kitagawa and Y. Moro-oka, *Inorg. Chem.*, 1997, **36**, 266; (f) S. Hikichi, H. Komatsuzaki, M. Akita and Y. Moro-oka, *J. Am. Chem. Soc.*, 1998, **120**, 4699; (g) S. Hikichi, M. Yoshizawa, Y. Sasakura, M. Akita and Y. Moro-oka, *J. Am. Chem. Soc.*, 1998, **120**, 10567; (h) M. Akita, N. Shirasawa, S. Hikichi and Y. Moro-oka, *Chem. Commun.*, 1998, 973; (i) T. Ogihara, S. Hikichi, M. Akita and Y. Moro-oka, *Inorg. Chem.*, 1998, **37**, 2614; (j) H. Komatsuzaki, Y. Nagasu, K. Suzuki, T. Shibusaki, M. Satoh, F. Ebina, S. Hikichi,

- M. Akita and Y. Moro-oka, *J. Chem. Soc., Dalton Trans.*, 1998, 511; (k) H. Komatsuzaki, S. Ichikawa, S. Hikichi, M. Akita and Y. Moro-oka, *Inorg. Chem.*, 1998, **37**, 3652; (l) M. Akita, K. Fujisawa, S. Hikichi and Y. Moro-oka, *Res. Chem. Inter.*, 1998, **24**, 291.
- 4 W. Kläui, *Angew. Chem., Int. Ed. Engl.*, 1990, **29**, 627.
- 5 J. P. Jesson, S. Trofimenko and D. R. Eaton, *J. Am. Chem. Soc.*, 1967, **89**, 3148; *Comprehensive Organometallic Chemistry II*, eds. E. W. Abel, F. G. A. Stone and G. Wilkinson, Pergamon, Oxford, 1995.
- 6 U. Siemeling, U. Vorfeld, R. Neumann and H. Stammler, *Organometallics*, 1998, **17**, 483.
- 7 (a) R. Han and G. Parkin, *J. Am. Chem. Soc.*, 1991, **113**, 9707; (b) R. Han, A. Looney, K. McNeill, G. Parkin, A. L. Rheingold and B. S. Haggerty, *J. Inorg. Biochem.*, 1993, **49**, 105; (c) A. Looney and G. Parkin, *Inorg. Chem.*, 1994, **33**, 1234; (d) A. Looney, A. Saleh, Y. Zhang and G. Parkin, *Inorg. Chem.*, 1994, **33**, 1158; (e) N. V. P. Kumar and D. S. Marynick, *Inorg. Chem.*, 1993, **32**, 1857; (f) R. Alsfasser, A. K. Powell, S. Trofimenko and H. Vahrenkamp, *Chem. Ber.*, 1993, **126**, 685; (g) T. Tanase, J. W. Yun and S. J. Lippard, *Inorg. Chem.*, 1995, **34**, 4220; (h) J. W. Yun, T. Tanase, L. E. Pence and S. J. Lippard, *J. Am. Chem. Soc.*, 1995, **117**, 4407; (i) C. He and S. J. Lippard, *J. Am. Chem. Soc.*, 1998, **120**, 105; (j) N. Kitajima, S. Hikichi, M. Tanaka and Y. Moro-oka, *J. Am. Chem. Soc.*, 1993, **115**, 5496.
- 8 W. Kläui, B. Lenders, B. Hessner and K. Evertz, *Organometallics*, 1988, **7**, 1357; B. Lenders, W. Kläui, M. Irmeler and G. Meyer, *J. Chem. Soc., Dalton Trans.*, 1990, 2069; W. Kläui and B. Lenders, *Chem. Ber.*, 1990, **123**, 2233; X. Feng, S. G. Bott and S. J. Lippard, *J. Am. Chem. Soc.*, 1989, **111**, 8046; M. Scotti, M. Valderrama, S. Rojas and W. Kläui, *J. Organomet. Chem.*, 1986, **301**, 369; W. Kläui, M. Scotti, M. Valderrama, S. Rolas, G. M. Sheldrick, P. G. Jones and T. Schroeder, *Angew. Chem., Int., Ed. Engl.*, 1985, **24**, 683; W. Kläui, H. Otto, W. Eberspach and E. Buchholz, *Chem. Ber.*, 1982, **115**, 1922; J. M. Power, K. Evertz, L. Henling, R. Marsh, W. P. Schaefer, J. A. Labinger and J. E. Bercaw, *Inorg. Chem.*, 1990, **29**, 5058; E. Kelson, L. Henling, W. P. Schaefer, J. A. Labinger and J. E. Bercaw, *Inorg. Chem.*, 1993, **32**, 2863; U. Kölle, G. Flunkert, R. Göriksen, M. Schmidt and U. Englert, *Angew. Chem., Int. Ed. Engl.*, 1992, **31**, 440; W.-H. Leung, E. Y. Y. Chan, I. D. Williams and W. T. Wong, *Organometallics*, 1997, **16**, 3234; T. R. Ward, S. Duclos, B. Therrien and K. Schenk, *Organometallics*, 1998, **17**, 2490; W. Kläui, A. Müller, W. Eberspach, R. Bose and I. Goldberg, *J. Am. Chem. Soc.*, 1987, **109**, 164; W. Kläui and H. Hamers, *J. Organomet. Chem.*, 1988, **345**, 287; W. Kläui and T. Hardt, *J. Organomet. Chem.*, 1996, **526**, 313; W. Kläui, T. Hardt, H.-J. Schulte and H. Hamers, *J. Organomet. Chem.*, 1995, **498**, 63; W. Kläui, M. Glaum, T. Wagner and M. A. Bennett, *J. Organomet. Chem.*, 1994, **472**, 355; B. Domhöver, H. Hamers, W. Kläui and M. Pfeffer, *J. Organomet. Chem.*, 1996, **522**, 197; B. Domhöver and W. Kläui, *J. Organomet. Chem.*, 1996, **522**, 207.
- 9 E. Dubler, L. Linowsky and W. Kläui, *Transition Met. Chem.*, 1979, **4**, 191.
- 10 C. K. Johnson, ORTEP, Report ORNL-5138, Oak Ridge National Laboratory, Oak Ridge, TN, 1976.
- 11 O. Krampe, C.-E. Song and W. Kläui, *Organometallics*, 1993, **12**, 4949.
- 12 W. Kläui, H.-O. Asbahr, G. Schramm and U. Englert, *Chem. Ber.*, 1997, **130**, 1223.
- 13 D. Stuart and N. Walker, *Acta Crystallogr., Sect. A*, 1979, **35**, 925.
- 14 TEXSAN, Crystal Structure Analysis Package, Molecular Structure Corporation, Houston, TX, 1985 and 1992.
- 15 *International Tables for X-Ray Crystallography*, Kynoch Press, Birmingham, 1975, vol. 4.
- 16 G. M. Sheldrick, SHELXS 86, University of Göttingen, 1986.
- 17 P. T. Beurskens, G. Admiraal, G. Buerskens, W. P. Bosman, S. Garcia-Granda, R. O. Gould, J. M. M. Smits and C. Smykalla, DIRDIF 92, Technical Report of the Crystallographic Laboratory, University of Nijmegen, 1992.
- 18 G. M. Sheldrick, SHELXL 93, University of Göttingen, 1993.

Paper 8/07816E