

An apparent anomaly concerned $n^2 + 13$, where there were numerous primes from $n = 0$ to 68 and from $n = 264$ to 298, but none in between. This striking maldistribution was most alarming, and threatened dire consequences to the Hardy-Littlewood conjecture, until the real explanation was found—pages 105 to 120 were missing in the reviewer's copy. Aside from this gross lapse, the volume has the usual elegance of the Royal Society Mathematical Tables.

D. S.

6[F, L].—C. B. HASELGROVE in collaboration with J. C. P. MILLER, *Tables of the Riemann Zeta Function*, Royal Society Mathematical Tables No. 6, Cambridge University Press, New York, 1960, xxiii + 80 p., 29 cm. Price \$9.50.

These important and fascinating tables are concerned primarily with $\zeta(\frac{1}{2} + it)$, the zeta function for real part $\frac{1}{2}$, and with its zeros. This complex function is expressed both in cartesian and polar forms:

$$\begin{aligned}\zeta\left(\frac{1}{2} + it\right) &= \Re\zeta\left(\frac{1}{2} + it\right) + i\Im\zeta\left(\frac{1}{2} + it\right) \\ &= Z(t)e^{-i\pi\theta(t)}.\end{aligned}$$

In the latter, $\theta(t)$ is continuous, with $\theta(0) = 0$, and the signed modulus $Z(t)$, given by

$$Z(t) = \pi^{-1/2} \frac{\Gamma(\frac{1}{4} + \frac{1}{2}it)}{|\Gamma(\frac{1}{4} + \frac{1}{2}it)|} \zeta(\frac{1}{2} + it),$$

changes sign at every zero. The n th zero, γ_n , is the n th solution of $Z(\gamma) = 0$ and the n th Gram point, g_n , is the solution of $\theta(g_n) = n$.

Table I gives $\Re\zeta(\frac{1}{2} + it)$, $\Im\zeta(\frac{1}{2} + it)$, $Z(t)$, and $\theta(t)$ to 6D for $t = 0(0.1)100$. $\Re\zeta(1 + it)$ and $\Im\zeta(1 + it)$ are also listed.

Table II gives $Z(t)$ to 6D for $t = 100(0.1)1000$.

Table III has two parts. Part 1, for $n = 1(1)650$, gives γ_n , g_{n-1} , and $\phi_n = (1/\pi)ph\zeta'(\frac{1}{2} + i\gamma_n)$ to 6D and $|\zeta'(\frac{1}{2} + i\gamma_n)|$ to 5D. Part 2, for $n = 651(1)1600$, gives γ_n to 6D and $|\zeta'(\frac{1}{2} + i\gamma_n)|$ to 5D.

Table IV gives $Z(t)$ to 6D for four other ranges of t ,

$t = 7000(0.1)7025$, $17120(0.1)17145$, $100000(0.1)100025$, $250000(0.1)250025$.

Also for these four ranges are given the zeros to 6D and derivatives to 5D. There are 28, 32, 38, and 42 zeros in the four ranges respectively.

Table V gives $(1/\pi)ph\Gamma(\frac{1}{2} + it)$ to 6D for $t = 0(0.1)50(1)600(2)1000$.

The inclusion of g_n and ϕ_n in part 1 of Table III allows the reader to study Gram's "Law" which states that the zeros and Gram points are interlaced:

$$\gamma_{n-1} < g_{n-2} < \gamma_n < g_{n-1} < \gamma_{n+1}.$$

A violation occurs if $|\phi_n| > \frac{1}{2}$. The first violation is for $n = 127$. The first double violation is for $n = 379$ and 380—i.e., there are three Gram points between γ_{379} and γ_{380} . In all, there are 22 violations in these 650 zeros. Gram's "Law" may also be expressed by saying that the complex $\zeta(\frac{1}{2} + it)$ approaches its zero via the 4th or 3rd quadrant. Thus the following statistics for these 650 zeros are of interest: 4th quadrant, 320 cases; 3rd quadrant, 308; 2nd quadrant, 13, and 1st quadrant, 9.

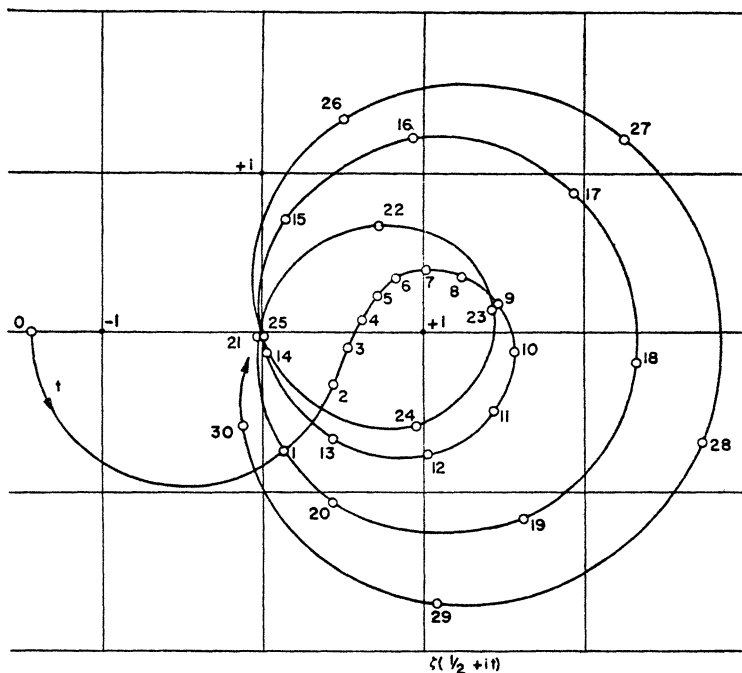

FIG. 1.— $\zeta(\frac{1}{2} + it)$ in the complex plane, for $0 \leq t \leq 30$.

This suggests the conjecture* that $\lim_{N \rightarrow \infty} (1/N) \sum_1^N \phi_n = 0$, that is, that

$$\zeta'(\frac{1}{2} + i\gamma_n)$$

is positive real in the mean. Since violations against the “Law” are associated with exceptionally close zeros or exceptionally large values of $Z(t)$, some extremes discovered by D. H. Lehmer are of interest, and are listed in Table IV:

$$\begin{aligned} \gamma_m &= 7005.062\ 866 \quad \text{and} \quad \gamma_{m+1} = 7005.100\ 565 \quad (m = ?) \\ Z(17123.1) &= 18.955\ 257. \end{aligned}$$

The tables of $\zeta(\frac{1}{2} + it)$ and of $Z(t)$ were both computed on two different machines, EDSAC and the Manchester Mark I, from two different asymptotic formulae, one due to Gram, the second a modification of the Riemann-Siegel formula due to Lehmer. A great deal of difficulty was experienced in eliminating discrepancies between the two methods, and three or four erroneous tables had to be discarded.

* Note added November 10, 1960. For the first 650 zeros this mean value, $\bar{\phi}_n$, shows such a marked trend toward zero that it is even probable that $|\sum \phi_n| / \sqrt{N}$ also tends toward zero. Taking only the “worst” points—that is, where $|\sum \phi_n|$ reaches a new maximum—sample values of $|\sum \phi_n| / \sqrt{N}$ are .0513, .0437, .0380, .0328, .0279, .0251, and .0217 for $n = 8, 33, 64, 126, 256, 379$, and 606 , respectively. It should be noted that $\bar{\phi}_n$ oscillates as it tends towards zero—up to $n = 650$ it changes sign 265 times. In particular, all 22 of the Gram violations, $|\phi_n| > \frac{1}{2}$, are associated with such sign changes. But this latter is almost inevitable up to $n = 650$, since the extreme values of $\sum \phi_n$ up to this limit are only $+5.20578$ for $n = 567$ and $-.533885$ for $n = 606$.

As to uses of the tables, Haselgrove himself has used the values of the first 600 zeros in his disproof of Pólya's conjecture. For later results on this theme, see R. S. Lehman, "On Liouville's function," *Math. Comp.*, v. 14, 1960, p. 311-320.

It is not inconceivable that study of these tables of $\zeta(\frac{1}{2} + it)$ may inspire some investigator to a new approach to the Riemann Hypothesis. Similarly, the table of $\zeta(1 + it)$ can be studied in connection with proofs of the prime number theorem. For both of these "uses," however, a graphical presentation is highly desirable, and it is regretted that a good collection of graphs was not included in this volume. For example, a graph of $\zeta(\frac{1}{2} + it)$ in the complex plane versus the parameter t —say from 0 to 30—is particularly interesting. See Fig. 1. Problem for the reader: If, in Fig. 1, the variable t is thought of as time, explain the initial counterclockwise motion in the orbit and the subsequent clockwise motion with a shorter and shorter mean period. Hint: Consider the formula

$$\zeta(s) = \left(1 - \frac{2}{2^s}\right)^{-1} \sum_{n=1}^{\infty} \frac{(-1)^{n+1}}{n^s}$$

for a fixed value of $s = \frac{1}{2} + it$. For what mean value of n does a block of consecutive terms in the series have all its terms in phase; in which block are alternate terms out of phase; and finally, which terms add in an essentially random manner?

Since it is known that Haselgrove has also computed complex zeros of the closely related $L(s)$ and other Dirichlet character series, and since he has not included these results, it would be desirable to issue a companion volume to make these related tables generally available.

Two very minor errors were noted in the Introduction.

Page xii, line 5: change $\zeta(\rho_n)$ to $\zeta'(\rho_n)$.

Page xvi, line 6 from bottom: change (3.7) to (3.32).

With respect to Liénard's table of $\zeta(n)$ for $n = 2(1)167$, which is mentioned on page xx, a recent extension should be noted: J. W. Wrench, Jr., "Further evaluation of Khintchine's constant," *Math. Comp.*, v. 14, 1960, p. 370-371.

D. S.

7[G, K, X, Z].—ANTHONY RALSTON & HERBERT S. WILF, *Mathematical Methods for Digital Computers*, John Wiley & Sons, Inc., New York, 1960, xi + 293 p., 27 cm. Price \$9.00.

This book contains contributions from twenty-four research workers in numerical analysis and related fields. Two of the contributors serve as editors, and, as the title implies, all contributors are definitely high-speed-computer oriented. It is interesting to note that ten of the twenty-four authors are from universities.

In the introduction it is stated that "the major purpose of this book is to present many—but by no means all—of the more commonly used tools of the modern numerical analyst along with some of the more promising newly developed methods. The motivation behind this presentation is not only to gather together in one place a partial survey of modern numerical methods but also, in each case, to acquaint the reader with the interplay between computer capabilities and processes of analysis".

The editors have done a good job in carrying out the purpose of the book. They have coordinated the efforts of their colleagues in a remarkable way. About twenty