

## On Maximal Finite Irreducible Subgroups of $GL(n, \mathbf{Z})$ II. The Six Dimensional Case

By Wilhelm Plesken and Michael Pohst\*

**Abstract.** All maximal finite absolutely irreducible subgroups of  $GL(6, \mathbf{Z})$  are determined up to  $\mathbf{Z}$ -equivalence.

**1. Introduction.** As promised in Part I [7], we determine all maximal finite irreducible subgroups of  $GL(6, \mathbf{Z})$  up to  $\mathbf{Z}$ -equivalence. There are 17  $\mathbf{Z}$ -classes. A set of representatives of these classes is described in Section 4, Theorem (4.1). Here, and in the following, irreducibility always means absolute irreducibility unless otherwise stated. A detailed description of the methods and definitions can be found in Part I [7].

In Section 2 we compute the minimal irreducible finite subgroups of  $GL(6, \mathbf{Z})$  up to  $\mathbf{Q}$ -equivalence. This turns out to be more complicated than in the seven dimensional case, which is due to the fact that six is no prime number. We get 33 groups whereas there were only two minimal irreducible finite groups in the five and seven dimensional cases. The  $\mathbf{Z}$ -classes of the natural representations of the 33 groups, respectively the  $\leftarrow$ -maximal centerings of the corresponding representation modules, were electronically computed on the IBM 370/158 at the California Institute of Technology. They and the quadratic forms fixed by these groups under the computed representations can be found in Section 3. The  $\mathbf{Z}$ -automorphs of these forms form a full set of representatives of the  $\mathbf{Z}$ -classes of the maximal finite irreducible subgroups of  $GL(6, \mathbf{Z})$ . They are described in Section 4.

We herewith want to thank the Mathematics Department of the California Institute of Technology for the generous grant to finance this project. In particular, we thank Professor H. Zassenhaus and Professor D. B. Wales for valuable suggestions.

**2. The Minimal Irreducible Finite Subgroups of  $GL(6, \mathbf{Z})$ .** Let  $G$  be a minimal irreducible subgroup of  $GL(6, \mathbf{Z})$ ,  $\Delta$  the natural representation of  $G$ , and  $N$  a maximal abelian normal subgroup of  $G$ . Applying Theorem (3.1) in [7] (an integral version of Clifford's Theorem), we may assume that the restriction  $\Delta|_N$  is equal to  $\Gamma_1 \dot{+} \cdots \dot{+} \Gamma_r$ , where  $\Gamma_1, \dots, \Gamma_r$  are integral representations of  $N$  satisfying  $\Gamma_i \sim_{\mathbf{Q}} k\Delta_i$  ( $i = 1, \dots, r; k \in \mathbf{N}$ ) and  $\Gamma_1(N) = \cdots = \Gamma_r(N)$ . (Transform  $\Delta$  rationally if necessary.) The  $\Delta_i$  ( $i = 1, \dots, r$ ) are inequivalent  $\mathbf{Q}$ -irreducible integral representations of  $N$  all of the same degree  $m$ .

---

Received February 16, 1976.

AMS (MOS) subject classifications (1970). Primary 20C10, 20-04, 10-04.

Key words and phrases. Integral matrix groups.

\*This paper originated from joint work at the California Institute of Technology under grants awarded by the Studienstiftung des deutschen Volkes and the Deutsche Forschungsgemeinschaft.

Copyright © 1977, American Mathematical Society

Therefore, we have to consider all possible solutions of  $6 = krm$  ( $k, r, m \in \mathbb{N}$ ). They are:

	$k$	$m$	$r$
(i)	1	1	6
(ii)	1	6	1
(iii)	1	3	2
(iv)	1	2	3
(v)	2	1	3
(vi)	2	3	1
(vii)	3	1	2
(viii)	3	2	1
(ix)	6	1	1.

But  $m = 3$  is impossible because of

(2.1) LEMMA.  $GL(n, \mathbb{Z})$  has no finite abelian  $\mathbb{Q}$ -irreducible subgroups if  $n$  is odd and greater than one.

*Proof.* (Compare the proof of Theorem (4.1) in [7].) The enveloping algebra of such a group would be a cyclotomic field of degree  $n$  over  $\mathbb{Q}$ . But then  $n$  had to be even. Q.E.D.

Therefore, cases (iii) and (vi) do not occur. We discuss the remaining cases in succession.

Case (i).  $G$  is a subgroup of the full monomial group  $H_6$ . By Theorem (3.2) in [7] the image of the associated permutation representation  $\varphi: G \rightarrow \tilde{S}_6: (g_{ij}) \mapsto (|g_{ij}|)$  is a minimal transitive permutation group of degree 6. An elementary computation shows that there exist three such groups up to equivalence:

$$\begin{aligned}
 P_1 &= \langle D((123456)) \rangle \quad (\cong C_6), \\
 P_2 &= \langle D((135)(246)), D((14)(32)(56)) \rangle \quad (\cong S_3), \\
 P_3 &= \langle D((135)(246)), D((12)(34)) \rangle \quad (\cong A_4),
 \end{aligned}$$

where  $D$  denotes the natural permutation representation of  $S_6$ ,  $D: S_6 \rightarrow GL(6, \mathbb{Z})$  with  $D(\pi)e_i = e_{\pi(i)}$  for  $\pi \in S_6$ ,  $i = 1, \dots, 6$ ,  $e_1, \dots, e_6$  the standard basis of  $\mathbb{Z}^{6 \times 1}$ . In each of the corresponding three subcases we have to determine the kernel of  $\varphi$ . The action of  $\varphi(G)$  on the diagonal matrices in  $H_6$  is the same as its natural action on  $\mathbb{Z}_2^{6 \times 1}$ . The subspace  $V$  in  $\mathbb{Z}_2^{6 \times 1}$ , which corresponds to  $\ker \varphi$ , has the following properties: the coordinate projections  $\pi_i: V \rightarrow \mathbb{Z}_2: (a_1, \dots, a_6)^T \rightarrow a_i$  are pairwise different ( $i = 1, \dots, 6$ ), and  $V$  is invariant under  $\varphi(G)$ . All the subspaces, which are invariant under  $\varphi(G) = P_1, P_2, P_3$ , respectively, can easily be obtained from the lattice of centerings of  $G_1, G_4$ , and  $G_9$  in Chapter 3. We find the following possibilities for  $N := \ker \varphi$ :

$$\begin{aligned}
 (\alpha) \quad \varphi(G) &= P_1, \\
 N_1 &= \langle g \operatorname{diag}(-1, 1, \dots, 1)g^{-1} \mid g \in P_2 \rangle,
 \end{aligned}$$

$$N_2 = \langle g \operatorname{diag}(-1, -1, -1, 1, 1, 1)g^{-1} \mid g \in P_2 \rangle,$$

$$N_3 = \langle g \operatorname{diag}(-1, 1, -1, 1, 1, 1)g^{-1} \mid g \in P_2 \rangle,$$

$$N_4 = \langle g \operatorname{diag}(-1, -1, 1, 1, 1, 1)g^{-1} \mid g \in P_2 \rangle.$$

Note:  $N_3 \subset N_4 \subset N_1$  and  $N_2 \subset N_1$ .

$$(\beta) \varphi(G) = P_2,$$

$$N_5 = \langle g \operatorname{diag}(-1, 1, \dots, 1)g^{-1} \mid g \in P_2 \rangle,$$

$$N_6 = \langle g \operatorname{diag}(1, 1, -1, -1, 1, -1)g^{-1} \mid g \in P_2 \rangle,$$

$$N_7 = \langle g \operatorname{diag}(-1, 1, 1, -1, 1, -1)g^{-1} \mid g \in P_2 \rangle,$$

$$N_8 = \langle g \operatorname{diag}(1, 1, -1, -1, -1, 1)g^{-1} \mid g \in P_2 \rangle,$$

$$N_9 = \langle g \operatorname{diag}(-1, 1, -1, 1, 1, 1)g^{-1} \mid g \in P_2 \rangle,$$

$$N_{10} = \langle g \operatorname{diag}(-1, -1, 1, -1, 1, -1)g^{-1} \mid g \in P_2 \rangle.$$

Note:  $N_6, N_7, N_8$  are contained in  $N_5$ , and  $N_9 \subset N_{10} \subset N_5$ .

$$(\gamma) \varphi(G) = P_3,$$

$$N_{11} = \langle g \operatorname{diag}(-1, 1, 1, 1, 1, 1)g^{-1} \mid g \in P_2 \rangle,$$

$$N_{12} = \langle g \operatorname{diag}(-1, 1, 1, -1, 1, 1)g^{-1} \mid g \in P_2 \rangle,$$

$$N_{13} = \langle g \operatorname{diag}(-1, 1, -1, 1, -1, 1)g^{-1} \mid g \in P_2 \rangle,$$

$$N_{14} = \langle g \operatorname{diag}(1, -1, -1, 1, -1, 1)g^{-1} \mid g \in P_2 \rangle,$$

$$N_{15} = \langle g \operatorname{diag}(-1, -1, 1, 1, 1, 1)g^{-1} \mid g \in P_2 \rangle.$$

Note:  $N_{12} \subset N_{11}$ ,  $N_{13} \subset N_{15} \subset N_{11}$ ,  $N_{14} \subset N_{15} \subset N_{11}$ .

We now determine the groups  $G$ . If the extension of  $\ker \varphi$  by  $\varphi(G)$  splits, it follows from Theorem (3.2) in [7], that  $\ker \varphi$  has to be minimal with the properties listed above.  $N_1, N_5, N_{11}$  consist of all diagonal matrices implying, that  $G$  splits over  $\ker \varphi$ . Since they are not minimal, they cannot occur as  $\ker \varphi$ . In the remaining cases we must look for the inverse images of the generators of  $P_i = \varphi(G)$  ( $i = 1, 2, 3$ ) under  $\varphi$ . They are of the form  $g = dd_0\varphi(g)$  with a fixed diagonal matrix  $d_0$  and  $d$  an arbitrary element in  $\ker \varphi$ .

In order to find a set of generators for  $G$  let  $\varphi(G) = \langle \bar{g}_1, \dots, \bar{g}_k \rangle$  together with defining relations  $r_l(\bar{g}_1, \dots, \bar{g}_k)$  ( $l = 1, \dots, s$ ) be a presentation of  $\varphi(G)$ . Choose one inverse image  $g_i = d_i \bar{g}_i$  of  $\bar{g}_i$ , where  $d_i$  is taken from a fixed set of representatives of the group of all diagonal matrices over  $\ker \varphi$  ( $i = 1, \dots, k$ ). The choice of the  $d_i$  is restricted by the conditions  $r_l(g_1, \dots, g_k) \in \ker \varphi$  ( $l = 1, \dots, s$ ). Then  $G$  is given by  $\langle g_1, \dots, g_k, n \rangle$  with a diagonal matrix  $n$  such that  $\ker \varphi = \langle gng^{-1} \mid g \in \varphi(G) \rangle$ . Of course, this procedure usually yields many  $\mathbf{Q}$ -equivalent groups  $G$ . In general, this can be avoided by a conjugation of the  $g_i$  ( $i = 1, \dots, k$ ) by elements, which normalize  $\ker \varphi$ .

As an example, we consider an inverse image  $g$  of  $D((135)(246))$  under  $\varphi$  in the cases  $\varphi(G) = P_2$  and  $\varphi(G) = P_3$ . By the Schur-Zassenhaus Theorem  $\langle g, \ker \varphi \rangle$  splits over  $\ker \varphi$ . Hence  $g = \operatorname{diag}(a_1, \dots, a_6)D((135)(246))$  can be chosen to be of order 3. The conjugation by  $\operatorname{diag}(1, 1, a_1, a_2, a_1a_3, a_2a_4)$  yields  $g = D((135)(246))$ .

Similar computations lead to the following complete list of groups.

(2.2) LEMMA. *The minimal irreducible finite subgroups  $G_i$  of  $GL(6, \mathbf{Z})$  in Case (i) up to  $\mathbf{Q}$ -equivalence are*

- ( $\alpha$ )  $\varphi(G_i) = \langle g_1 = D((123456)) \rangle \quad (i = 1, 2, 3),$   
 $G_1 = \langle g_1, \text{diag}(-1, -1, -1, 1, 1, 1) \rangle \quad (\ker \varphi = N_2),$   
 $G_2 = \langle g_1, \text{diag}(-1, 1, -1, 1, 1, 1) \rangle \quad (\ker \varphi = N_3),$   
 $G_3 = \langle \text{diag}(-1, 1, 1, 1, 1, 1)g_1, \text{diag}(-1, -1, 1, 1, 1, 1) \rangle \quad (\ker \varphi = N_4).$
- ( $\beta$ )  $\varphi(G_i) = \langle g_1 = D((135)(246)), g_2 = D((14)(23)(56)) \rangle \quad (i = 4, \dots, 8),$   
 $G_4 = \langle g_1, g_2, \text{diag}(1, 1, -1, -1, 1, -1) \rangle \quad (\ker \varphi = N_6),$   
 $G_5 = \langle g_1, g_2, \text{diag}(-1, 1, 1, -1, 1, -1) \rangle \quad (\ker \varphi = N_7),$   
 $G_6 = \langle g_1, g_2, \text{diag}(1, 1, -1, -1, -1, 1) \rangle \quad (\ker \varphi = N_8),$   
 $G_7 = \langle g_1, g_2, \text{diag}(-1, 1, -1, 1, 1, 1) \rangle \quad (\ker \varphi = N_9),$   
 $G_8 = \langle g_1, \text{diag}(-1, 1, 1, 1, 1, 1)g_2, \text{diag}(-1, -1, 1, -1, 1, -1) \rangle$   
 $(\ker \varphi = N_{10}).$
- ( $\gamma$ )  $\varphi(G_i) = \langle g_1 = D((135)(246)), g_2 = D((12)(34)) \rangle \quad (i = 9, \dots, 15),$   
 $G_9 = \langle g_1, g_2, \text{diag}(-1, 1, 1, -1, 1, 1) \rangle \quad (\ker \varphi = N_{12}),$   
 $G_{10} = \langle g_1, g_2, \text{diag}(-1, 1, -1, 1, -1, 1) \rangle \quad (\ker \varphi = N_{13}),$   
 $G_{11} = \langle g_1, \text{diag}(1, 1, 1, 1, 1, -1)g_2, \text{diag}(-1, 1, -1, 1, -1, 1) \rangle$   
 $(\ker \varphi = N_{13}),$   
 $G_{12} = \langle g_1, g_2, \text{diag}(1, -1, -1, 1, -1, 1) \rangle \quad (\ker \varphi = N_{14}),$   
 $G_{13} = \langle g_1, \text{diag}(1, 1, 1, 1, -1, 1)g_2, \text{diag}(1, -1, -1, 1, -1, 1) \rangle$   
 $(\ker \varphi = N_{14}),$   
 $G_{14} = \langle g_1, \text{diag}(1, 1, 1, -1, 1, 1)g_2, \text{diag}(1, -1, -1, 1, -1, 1) \rangle$   
 $(\ker \varphi = N_{14}),$   
 $G_{15} = \langle g_1, \text{diag}(1, 1, 1, -1, 1, -1)g_2, \text{diag}(1, -1, -1, 1, -1, 1) \rangle$   
 $(\ker \varphi = N_{14}).$

We remark that some of these groups may still be  $\mathbf{Q}$ -equivalent.

Case (ii). In this case our normal subgroup  $N$  is  $\mathbf{Q}$ -irreducible. Hence the enveloping algebra  $E(N)$  of  $N$  in  $\mathbf{Q}^{6 \times 6}$  is simple and commutative, i.e. a field by Wedderburn's Theorem. Then  $N$  must be cyclic and  $E(N)$  a cyclotomic field. Its degree is six, since  $E(N) \subseteq \mathbf{Q}^{6 \times 6}$  is irreducible. The degrees of cyclotomic fields are given by the Euler  $\varphi$ -function. So we must find all solutions of  $\varphi(|N|) = 6$ . They are  $|N| = 7, 14, 9, 18$ .

Let  $N$  be generated by an element  $g$ . There exists a matrix  $x \in GL(6, \mathbf{C})$  with  $xgx^{-1} = \text{diag}(\zeta_1, \dots, \zeta_6)$ , where the  $\zeta_i$  ( $i = 1, \dots, 6$ ) are primitive  $r$ th roots of unity,  $r \in \{7, 14, 9, 18\}$ . Therefore,  $xGx^{-1}$  is an imprimitive group. Because of the irreducibility of  $G$  the  $\zeta_i$  must be permuted transitively under conjugation by the

elements of  $xGx^{-1}$ . Hence  $G$  is isomorphic to an extension of the cyclic group  $N$  by the full automorphism group of  $N$ , which is cyclic of order 6. But there exist only the splitting extensions. Each of them has exactly one representation of degree 6.

(2.3). LEMMA. *The minimal irreducible finite subgroups of  $GL(6, \mathbf{Z})$  in Case (ii) up to  $\mathbf{Q}$ -equivalence are*

$$G_{16} = \left\langle g_1 = \begin{pmatrix} 0 & 0 & 0 & 0 & 0 & -1 \\ 1 & 0 & 0 & 0 & 0 & -1 \\ 0 & 1 & 0 & 0 & 0 & -1 \\ 0 & 0 & 1 & 0 & 0 & -1 \\ 0 & 0 & 0 & 1 & 0 & -1 \\ 0 & 0 & 0 & 0 & 1 & -1 \end{pmatrix}, D((132645)) \right\rangle \text{ of order } 7 \cdot 6,$$

$$G_{17} = \left\langle g_2 = \begin{pmatrix} 0 & 0 & B_1 \\ I_2 & 0 & 0 \\ 0 & I_2 & 0 \end{pmatrix}, g_3 = \begin{pmatrix} B_2 & 0 & 0 \\ 0 & 0 & B_3 \\ 0 & B_2 & 0 \end{pmatrix} \right\rangle \text{ of order } 9 \cdot 6,$$

where

$$B_1 = \begin{pmatrix} 0 & -1 \\ 1 & -1 \end{pmatrix}, \quad B_2 = \begin{pmatrix} 1 & -1 \\ 0 & -1 \end{pmatrix}, \quad B_3 = \begin{pmatrix} 0 & 1 \\ 1 & 0 \end{pmatrix}.$$

*Proof.* The maximal abelian normal subgroup  $N$  of  $G_{16}$  is generated by  $g_1$  and is of order 7.  $D((132645))$  conjugates  $g_1$  into  $g_1^3$  and corresponds to a generator of the automorphism group of  $N$ . Similar relations hold for  $G_{17}$ , where  $N$  has order 9. Clearly both groups are irreducible.

If  $N$  is of order 14 or 18, then  $G$  can be chosen as  $\langle G_{16}, -I_6 \rangle, \langle G_{17}, -I_6 \rangle$ , respectively. These groups are not minimal irreducible. Q.E.D.

Case (iv). We shall need

(2.4) LEMMA. *The  $\mathbf{Q}$ -irreducible abelian finite subgroups of  $GL(2, \mathbf{Z})$  are up to  $\mathbf{Z}$ -equivalence*

$$J_1 = \left\langle \left\langle \begin{pmatrix} 0 & -1 \\ 1 & 0 \end{pmatrix} \right\rangle \right\rangle (\cong C_4), \quad J_2 = \left\langle \left\langle \begin{pmatrix} 0 & -1 \\ 1 & -1 \end{pmatrix} \right\rangle \right\rangle (\cong C_3), \text{ and}$$

$$J_3 = \left\langle \left\langle \begin{pmatrix} 0 & 1 \\ -1 & 1 \end{pmatrix} \right\rangle \right\rangle (\cong C_6).$$

*Proof.* Let  $N$  be such a group. Similar arguments as in Case (ii) show that  $N$  is cyclic of order  $r = 4, 3$ , or  $6$ , which are all solutions of the equation  $\varphi(r) = 2$ . As generating matrices, we can choose the accompanying matrices of the corresponding cyclotomic polynomials. Because the class number in the  $r$ th cyclotomic field is one, a theorem of Latimer and McDuffee [11] proves that there is only one  $\mathbf{Z}$ -class for these cyclic groups. Q.E.D.

The normalizers of  $J_1, J_2, J_3$  in  $GL(2, \mathbf{Z})$  are

$$\bar{J}_1 = \left\langle J_1, \begin{pmatrix} 0 & 1 \\ 1 & 0 \end{pmatrix} \right\rangle, \quad \bar{J}_2 = \bar{J}_3 = \left\langle J_3, \begin{pmatrix} 0 & 1 \\ 1 & 0 \end{pmatrix} \right\rangle$$

respectively. An easy computation shows, that the normalizers of these groups  $\bar{J}_i$  in  $GL(2, \mathbf{Q})$  already induce the full automorphism groups of the  $\bar{J}_i$ .

Next we describe our group  $G$  in terms of the maximal abelian normal subgroup  $N$  and the factor group  $G/N$ .

(2.5) LEMMA.  $G/N$  is isomorphic to one of the groups  $\bar{P}_1 = \langle D((145236)) \rangle$ ,  $\bar{P}_2 = \langle D((135)(246)) \rangle$ ,  $D((14)(32)(56))$ ,  $\bar{P}_3 = \langle D((135)(246)) \rangle$ ,  $D((12)(34))$ .  $N$  is contained in  $J_i + J_i + J_i$  ( $i \in \{1, 2, 3\}$ ), and  $G$  is a subgroup of  $(J_i + J_i + J_i) \cdot P_j$  ( $j \in \{1, 2, 3\}$ ). Moreover  $N$  satisfies:

- (1)  $N$  is invariant under conjugation with  $\bar{P}_j$ ,
- (2) the projections  $\Delta_\nu: N \rightarrow J_i: \text{diag}(A_1, A_2, A_3) \mapsto A_\nu$  ( $\nu = 1, 2, 3$ ) are surjective and pairwise  $\mathbf{Q}$ -inequivalent.

If  $G$  splits over  $N$ , then  $N$  does not contain a proper subgroup with properties (1) and (2). (If  $i = 3$ , it may be changed to  $i = 2$ .)

*Proof.* Since we are in Case (iv), Lemma (2.4) implies that  $N$  is a subgroup of  $J_i + J_i + J_i$  ( $i \in \{1, 2, 3\}$ ) with property (2) and that the normalizer of  $N$  in  $GL(6, \mathbf{Z})$  is contained in  $\bar{J}_i \sim S_3$ . Therefore,  $G$  is a subgroup of  $\bar{J}_i \sim S_3$ . Let  $M$  be the  $\mathbf{C}G$ -module belonging to the natural representation of  $G$ . As  $\mathbf{C}N$ -module  $M$  decomposes into the direct sum of six one dimensional inequivalent  $\mathbf{C}N$ -modules  $M_i$  ( $i = 1, \dots, 6$ ). These are permuted by the elements of  $G$ .  $G$  is irreducible if and only if it permutes the  $M_i$  transitively. The kernel of this permutation representation is  $N$  and because  $G$  is minimal irreducible  $G/N$  has to be isomorphic to one of the groups  $C_6, S_3, A_4$  listed as  $P_1, P_2, P_3$  in Case (i).

For  $g \in G \leq \bar{J}_i \sim S_3$  we have the unique factorization  $g = g\bar{g}$  with

$$g \in J_i + J_i + J_i \quad (i \in \{1, 3\}) \quad \text{and} \quad \bar{g} \in \left\langle \begin{pmatrix} 0 & 1 \\ 1 & 0 \end{pmatrix} \right\rangle \sim S_3.$$

The first two assertions and property (1) of  $N$  follow easily. If  $G$  splits over  $N$ , then  $N$  is certainly minimal with properties (1) and (2). Q.E.D.

Since  $D((135)(246))$  is contained in  $\bar{P}_1, \bar{P}_2, \bar{P}_3$  we first determine all subgroups  $N$  of  $J_i + J_i + J_i$  ( $i = 1, 2, 3$ ) which are invariant under conjugation by  $\langle D((135)(246)) \rangle$ . They are:

$$(2.6) \quad (\alpha) \quad N \leq J_1 + J_1 + J_1,$$

- $N_1 = \langle \text{diag}(A, A, -I_2), \text{diag}(A, -I_2, A) \rangle$  of order 16,
- $N_2 = \langle \text{diag}(\pm A, \pm A, \pm A) \rangle$  of order 16,
- $N_3 = \langle \text{diag}(I_2, A, A), \text{diag}(A, I_2, A), \text{diag}(A, A, I_2) \rangle$  of order 32,
- $N_4 = J_1 + J_1 + J_1$  of order 64,

where  $A = \begin{pmatrix} 0 & -1 \\ 1 & 0 \end{pmatrix}$  generates  $J_1$ .

$$(\beta) \quad N \leq J_2 + J_2 + J_2,$$

$$N_5 = \langle \text{diag}(B, B, B), \text{diag}(B, B^2, I_2) \rangle \quad \text{of order } 9,$$

$$N_6 = J_2 \dot{+} J_2 \dot{+} J_2 \quad \text{of order } 27,$$

where  $B = \begin{pmatrix} 0 & -1 \\ 1 & -1 \end{pmatrix}$  generates  $J_2$ .

$$(\gamma) \quad N \leq J_3 \dot{+} J_3 \dot{+} J_3,$$

$$N_7 = \langle \text{diag}(B, B, B) \rangle \cdot U_1 \quad \text{of order } 3 \cdot 4,$$

$$N_8 = \langle \text{diag}(B, B, B) \rangle \cdot U_2 \quad \text{of order } 3 \cdot 8,$$

$$N_9 = N_5 \cdot \langle -I_6 \rangle \quad \text{of order } 3^2 \cdot 2,$$

$$N_{10} = N_5 \cdot U_1 \quad \text{of order } 3^2 \cdot 4,$$

$$N_{11} = N_5 \cdot U_2 \quad \text{of order } 3^2 \cdot 8,$$

$$N_{12} = N_6 \cdot \langle -I_6 \rangle \quad \text{of order } 3^3 \cdot 2,$$

$$N_{13} = N_6 \cdot U_1 \quad \text{of order } 3^3 \cdot 4,$$

$$N_{14} = J_3 \dot{+} J_3 \dot{+} J_3 \quad \text{of order } 3^3 \cdot 8,$$

where  $U_1 = \langle \text{diag}(-I_2, -I_2, I_2), \text{diag}(-I_2, I_2, -I_2) \rangle$  and  $U_2 = \langle \text{diag}(\pm I_2, \pm I_2, \pm I_2) \rangle$ .

Note  $N_1 \subset N_3 \subset N_4$ ,  $N_2 \subset N_4$ ,  $N_5 \subset N_i$  ( $i \in \{6, 9, 10, \dots, 14\}$ ),  $N_7 \subset N_i$  ( $i \in \{8, 10, 11, 13, 14\}$ ).

All these groups  $N_i$  ( $i = 1, \dots, 14$ ) turn out to be invariant under  $\bar{P}_1$  and  $\bar{P}_2$ . Under  $\bar{P}_3$  only  $N_2, N_3, N_4, N_6, N_{12}, N_{13}$ , and  $N_{14}$  stay invariant.

Using (2.5) and (2.6), the groups  $G$  can be determined in the same way as in Case (i). ( $J_1 \dot{+} J_1 \dot{+} J_1$ , respectively,  $J_3 \dot{+} J_3 \dot{+} J_3$  take the place of the group of all diagonal matrices.) Our remark about the normalizers of  $\bar{J}_i$  ( $i = 1, 2, 3$ ) in  $GL(2, \mathbf{Q})$  enables us to detect some  $\mathbf{Q}$ -equivalent groups. We also eliminate groups, which are obviously  $\mathbf{Q}$ -equivalent to one of the groups  $G_1, \dots, G_{17}$ . We end up with the following list:

(2.7) LEMMA. *The minimal irreducible finite subgroups of  $GL(6, \mathbf{Z})$  in Case (iv) are  $\mathbf{Q}$ -equivalent to one of the groups  $G_i$  ( $i = 1, \dots, 30; i \neq 16$ ).  $G_{18}, \dots, G_{30}$  are given by*

$$(\beta_1) \quad G/N \cong \bar{P}_2 \quad \text{and} \quad N \leq J_1 \dot{+} J_1 \dot{+} J_1,$$

$$G_{18} = \langle g_1, g_2, \text{diag}(A, A, -I_2) \rangle \quad (\ker \varphi = N_1),$$

$$G_{19} = \langle g_1, \text{diag}(A, I_2, I_2)g_2, \text{diag}(A, A, -I_2) \rangle \quad (\ker \varphi = N_1),$$

$$G_{20} = \langle g_1, g_2, \text{diag}(A, -A, A) \rangle \quad (\ker \varphi = N_2),$$

where  $g_1 = D((135)(246))$ ,  $g_2 = D((14)(32)(56))$ , and  $A = \begin{pmatrix} 0 & -1 \\ 1 & 0 \end{pmatrix}$  generates  $J_1$ .

$$(\gamma_1) \quad G/N \cong \bar{P}_3 \quad \text{and} \quad N \leq J_1 \dot{+} J_1 \dot{+} J_1,$$

$$G_{21} = \langle g_1, g_3, \text{diag}(A, -A, A) \rangle \quad (\ker \varphi = N_2),$$

$$G_{22} = \langle \text{diag}(A, I_2, I_2)g_1, g_3, \text{diag}(A, -A, A) \rangle \quad (\ker \varphi = N_2),$$

where  $g_3 = \text{diag}(A, I_2, I_2)D((12)(34))$  and  $g_1, A$  as in  $(\beta_1)$ .

$$(\alpha_2) \quad G/N \cong \bar{P}_1 \quad \text{and} \quad N \leq J_2 \dot{+} J_2 \dot{+} J_2, \\ G_{23} = \langle D((145236)), \text{diag}(B, B^2, I_2) \rangle \quad (\ker \varphi = N_5),$$

where  $B = \begin{pmatrix} 0 & -1 \\ 1 & -1 \end{pmatrix}$  generates  $J_2$ .

$$(\alpha_3) \quad G/N \cong \bar{P}_1 \quad \text{and} \quad N \leq J_3 \dot{+} J_3 \dot{+} J_3, \\ G_{24} = \langle D((145236)), \text{diag}(-B, -B, B) \rangle \quad (\ker \varphi = N_7).$$

$$(\beta_2) \quad G/N \cong \bar{P}_2 \quad \text{and} \quad N \leq J_2 \dot{+} J_2 \dot{+} J_2, \\ G_{25} = \langle g_1, g_2, \text{diag}(B, B^2, I_2) \rangle \quad (\ker \varphi = N_5), \\ G_{26} = \langle g_1, \text{diag}(B, I_2, I_2)g_2, \text{diag}(B, B^2, I_2) \rangle \quad (\ker \varphi = N_5),$$

with  $g_1, g_2$  as defined in  $(\beta_1)$ .

$$(\beta_3) \quad G/N \cong \bar{P}_2 \quad \text{and} \quad N \leq J_3 \dot{+} J_3 \dot{+} J_3, \\ G_{27} = \langle g_1, g_2, \text{diag}(-B, -B, B) \rangle \quad (\ker \varphi = N_7), \\ G_{28} = \langle \text{diag}(I_2, I_2, B)g_1, \text{diag}(I_2, I_2, B)g_2, \text{diag}(-B, -B, B) \rangle \quad (\ker \varphi = N_7).$$

$$(\gamma_2) \quad G/N \cong \bar{P}_3 \quad \text{and} \quad N \leq J_2 \dot{+} J_2 \dot{+} J_2, \\ G_{29} = \langle g_1, D((12)(34)), \text{diag}(B, I_2, I_2) \rangle \quad (\ker \varphi = N_6), \\ G_{30} = \langle g_1, \text{diag}(I_2, -I_2, -I_2)D((12)(34)), \text{diag}(B, I_2, I_2) \rangle \quad (\ker \varphi = N_6).$$

Some of these groups may still be  $\mathbf{Q}$ -equivalent.

Case (v). Clearly there are only two possibilities for our normal subgroup  $N$ :

$$N_1 = \langle \text{diag}(\pm I_2, \pm I_2, \pm I_2) \rangle, \\ N_2 = \langle \text{diag}(-I_2, -I_2, I_2), \text{diag}(I_2, -I_2, -I_2) \rangle.$$

It is well known that there exist only two irreducible maximal finite subgroups of  $GL(2, \mathbf{Z})$  up to  $\mathbf{Z}$ -equivalence:

$$\bar{J}_1 = \left\langle \left( \begin{pmatrix} 0 & -1 \\ 1 & 0 \end{pmatrix}, \begin{pmatrix} 0 & 1 \\ 1 & 0 \end{pmatrix} \right) \right\rangle \quad \text{and} \quad \bar{J}_2 = \left\langle \left( \begin{pmatrix} 0 & 1 \\ -1 & 1 \end{pmatrix}, \begin{pmatrix} 0 & 1 \\ 1 & 0 \end{pmatrix} \right) \right\rangle.$$

So  $G$  has to be  $\mathbf{Z}$ -equivalent to a subgroup of either  $\bar{J}_1 \sim S_3$  or  $\bar{J}_2 \sim S_3$ . First, we show that  $G \leq J_2 \sim S_3$  cannot occur. We consider all  $(2 \times 2)$ -block diagonal matrices in  $G \leq \bar{J}_2 \sim S_3$ . The inertia group of  $\Delta_1$  (defined at the beginning of this chapter) contains the group of all block diagonal matrices as a subgroup of index 1 or 2. On the other hand 3 has to divide the order of the inertia group ( $|\bar{J}_2| = 12$ ). Hence there is a diagonal matrix of order 3. So

$$(J_3 \dot{+} J_3 \dot{+} J_3) \cap G \quad \text{with} \quad J_3 = \left\langle \left( \begin{pmatrix} 0 & 1 \\ -1 & 1 \end{pmatrix} \right) \right\rangle$$

contains  $N = N_1$  or  $N = N_2$  properly and is an abelian normal subgroup of  $G_1$  since  $J_3$  is a characteristic subgroup of  $\bar{J}_2$ . This is a contradiction. In case  $G \leq \bar{J}_1 \sim S_3$



after a suitable conjugation  $G$  must contain the matrix  $D((135)(246))$ . For  $G$  certainly contains a matrix  $h = \text{diag}(a, b, c)D((135)(246))$  of order 3 with  $a, b, c \in \bar{J}_1$ . Conjugation by  $\text{diag}(I_2, b^{-1}, a^{-1})$  leaves  $N$  invariant and transforms  $h$  into  $D((135)(246))$ .

Next we assume that there is no element  $\text{diag}(A, x, y)$  in  $G$  with  $A = \begin{pmatrix} 0 & -1 \\ 1 & 0 \end{pmatrix}$  and  $x, y \in \bar{J}_1$ . Then the inertia group of  $\Delta_1$  (see above) must contain two elements

$$h_1 = \text{diag}(A, u, v)D((35)(46)) \quad \text{and} \quad h_2 = \text{diag}\left(\begin{pmatrix} 0 & 1 \\ 1 & 0 \end{pmatrix}, u', v'\right)D((35)(46))$$

with  $u, v, u', v' \in \bar{J}_1$ . The product  $h_1 h_2$  is the block diagonal matrix

$$\text{diag}\left(\begin{pmatrix} -1 & 0 \\ 0 & 1 \end{pmatrix}, uv', vu'\right).$$

According to our assumption  $uv'$  or  $vu'$  cannot be equal to  $A$  or  $A^{-1}$ . So  $uv'$  and  $vu'$  must be contained in

$$\left\{ \pm I_2, \pm \begin{pmatrix} 0 & 1 \\ 1 & 0 \end{pmatrix}, \pm \begin{pmatrix} -1 & 0 \\ 0 & 1 \end{pmatrix} \right\}.$$

Since all diagonal matrices in  $G$  form an abelian normal subgroup,  $uv'$  and  $vu'$  are certainly not in

$$\left\{ \pm I_2, \pm \begin{pmatrix} -1 & 0 \\ 0 & 1 \end{pmatrix} \right\}.$$

Inspecting the remaining possibilities, one easily gets a contradiction to the maximality of  $N = N_1$  or  $N = N_2$ .

So there must be an element  $\text{diag}(A, x, y)$  in  $G$  with  $x, y \in \bar{J}_1$ . Similar considerations as above lead to one group  $G$ .

(2.8) LEMMA. *The minimal irreducible finite subgroups of  $GL(6, \mathbf{Z})$  in case (v) are  $\mathbf{Q}$ -equivalent to one of the groups  $G_1, \dots, G_{30}$  or to*

$$G_{31} = \left\langle D((135)(246)), \text{diag}\left(\begin{pmatrix} 0 & -1 \\ 1 & 0 \end{pmatrix}, \begin{pmatrix} -1 & 0 \\ 0 & 1 \end{pmatrix}, \begin{pmatrix} 0 & 1 \\ 1 & 0 \end{pmatrix}\right) \right\rangle.$$

Case (vii).  $N$  must be the group  $\langle \text{diag}(\pm I_3, \pm I_3) \rangle$ . Then  $G$  is  $\mathbf{Q}$ -equivalent to a subgroup of  $H_3 \sim C_2$ , because there is only one maximal finite irreducible subgroup of  $GL(3, \mathbf{Z})$  up to  $\mathbf{Q}$ -equivalence. (Note  $H_3$  is the full monomial group of degree 3.) The inertia group  $I$  of  $\Delta_1$  (defined at the beginning of this section) consists of matrices  $\text{diag}(A_1, A_2)$  with  $A_1, A_2$  in an irreducible subgroup  $S$  of  $H_3$ .  $I$  is a sub-direct product of  $S$  with itself. So there exists an automorphism  $\tau$  of  $S$  such that  $I$  contains  $\text{diag}(A, \tau(A))$  for all  $A \in S$ . The irreducible subgroups of  $H_3 \cong C_2 \times S_4$  are isomorphic to  $C_2 \times S_4, C_2 \times A_4, S_4$ , or  $A_4$ . Therefore each automorphism of  $S$  maps the diagonal matrices of  $S$  on diagonal matrices.  $S$  certainly contains a diagonal matrix  $d \neq \pm I_3$ , but then  $\text{diag}(d, \tau(d)) \notin \langle \text{diag}(\pm I_3, \pm I_3) \rangle$ , which is a contradiction.

(2.9) LEMMA. *In case (vii) there are no minimal irreducible finite subgroups of  $GL(6, \mathbf{Z})$ .*

Case (viii). By Lemma (2.4)  $N$  must be  $\mathbf{Z}$ -equivalent to one of the three groups

$$N_1 = \langle \text{diag}(A, A, A) \rangle \quad \text{with } A = \begin{pmatrix} 0 & -1 \\ 1 & 0 \end{pmatrix},$$

$$N_2 = \langle \text{diag}(B, B, B) \rangle \quad \text{with } B = \begin{pmatrix} 0 & -1 \\ 1 & -1 \end{pmatrix},$$

$$N_3 = \langle \text{diag}(-B, -B, -B) \rangle.$$

At first we consider the centralizer  $C(N)$  of  $N$  in  $GL(6, \mathbf{Z})$ . An easy computation yields that  $C(N)$  consists of all matrices  $(a_{ij})_{i,j=1,2,3}$  where the  $a_{ij}$  are in the enveloping algebra  $E_{\mathbf{Z}}(N)$  of  $N$  in  $\mathbf{Z}^{2 \times 2}$  and  $\det(a_{ij}) = \pm 1$ . (Note  $E_{\mathbf{Z}}(N)$  are the algebraic integers in the fourth respectively sixth cyclotomic field.) We conclude that the centralizer  $C_G(N)$  of  $N$  in  $G$  has a faithful representation  $\Omega: C_G(N) \rightarrow GL(3, \mathbf{C})$ . This representation has to be irreducible, because  $G$  contains  $C_G(N)$  of index 1 or 2 and the natural representation of  $C_G(N)$  is  $\mathbf{C}$ -equivalent to  $\Omega + \bar{\Omega}$ . ( $\bar{\Omega}$  is the complex conjugate representation of  $\Omega$ .) The values of the character of  $\Omega$  lie in the fourth respectively sixth cyclotomic field. Moreover,  $C_G(N)$  is nonsolvable, since  $N$  is central in  $C_G(N)$  and a maximal abelian normal subgroup of  $C_G(N)$  over  $N$ . An inspection of the character tables [9], [10] of the nonsolvable complex linear groups of third degree [1] shows, that there are no groups with these conditions.

(2.10) LEMMA. *In case (viii) there are no minimal irreducible finite subgroups of  $GL(6, \mathbf{Z})$ .*

Case (ix). In this case we get  $N = \langle I_6 \rangle$  or  $N = \langle -I_6 \rangle$  for our maximal abelian normal subgroup  $N$  of  $G$ . Hence  $N$  is the center of  $G$ , and  $G$  is nonsolvable.

At first we assume that  $SL(6, \mathbf{Z}) \cap G =: \tilde{G}$  is reducible. By Clifford's Theorem  $\tilde{G}$  is  $\mathbf{C}$ -equivalent to a group of the form  $\{\text{diag}(\Omega_1(g), \Omega_2(g)) | g \in G\}$ , where the  $\Omega_i$  ( $i = 1, 2$ ) are irreducible faithful representations of degree 3, such that the natural representation of  $\tilde{G}$  is  $\mathbf{C}$ -equivalent to  $\Omega_1 + \Omega_2$ . The center of  $\Omega_i(G)$  ( $i = 1, 2$ ) is of order 1 or 2. From [1], [9], [10] we get  $\tilde{G} \cong A_5$  or  $\tilde{G} \cong PSL(2, 7)$ . While the first possibility leads to a minimal irreducible group  $G_{32} \cong S_5$ , the second contains the irreducible group  $G_{16}$ , as we shall show in Section 4.

Now let  $G$  be contained in  $SL(6, \mathbf{Z})$ . If  $G$  has a proper normal subgroup  $U$ , such that the natural representation  $\Delta$  of  $G$  splits into  $\kappa$  irreducible nonequivalent  $\mathbf{C}$ -representations:  $\Delta|_U \sim_{\mathbf{C}} \Omega_1 + \dots + \Omega_{\kappa}$ , then  $\kappa$  has to be 2, 3, or 6. For  $\kappa = 6$  the group  $G$  must be solvable ( $G$  is minimal irreducible!). For  $\kappa = 3$  the normal subgroup  $U$  cannot be solvable. But there is only one nonsolvable finite subgroup of  $GL(2, \mathbf{C})$  [1], which is isomorphic to the icosahedron group. The corresponding representation of the icosahedron group has a nonrational character, which leads to a contradiction. For  $\kappa = 2$  we conclude as in the first part of this case. At last we must consider the possibility that  $G$  is quasiprimitive as defined in [5]. From the

complete list of these groups in [5] we have to take only those, which are minimal irreducible and whose natural representation can be made rational. By [6] the order of  $G$  must divide  $2^{10}3^45 \cdot 7$ . Further the center of  $G$  must be of order 1 or 2, and  $G$  must not contain an abelian normal subgroup unequal  $\langle I_6 \rangle$  or  $\langle -I_6 \rangle$ . There are the following groups left:

- I.  $G/N \cong A_5 \times V$  where  $V \cong PSL(2, 7), A_5$  or  $A_6$ ,
- II.  $G/N \cong A_5$  or  $S_5, N = \langle -I_6 \rangle$ ,
- III.  $G/N \cong A_7$  or  $S_7, N = \langle I_6 \rangle$ ,
- IV.  $G/N \cong PSL(2, 7), N = \langle I_6 \rangle$ ,
- V.  $G/N \cong PSU_4(2), N = \langle I_6 \rangle$ ,
- VI.  $G/N \cong U_3(3), N = \langle I_6 \rangle$ .

We can eliminate most of the cases.

Ad I. These groups have no rational characters.

Ad II. The corresponding characters are of the second kind, hence these groups cannot be subgroups of  $GL(6, \mathbf{Z})$ .

Ad III. Since the group  $PSL(2, 7)$  has a doubly transitive permutation representation,  $A_7$  has a subgroup isomorphic to  $PSL(2, 7)$ . So  $G \cong A_7$  or  $S_7$  cannot be minimal irreducible subgroups of  $GL(6, \mathbf{Z})$ .

Ad V. We shall prove in Section 4 that this group contains a proper irreducible subgroup.

Ad VI. From the character table of this group [3] we see that  $G \cong U_3(3)$  has no rational irreducible representation of degree six.

In the remaining cases we get new groups  $G$ .

(2.11) LEMMA. *The minimal irreducible finite subgroups of  $GL(6, \mathbf{Z})$  in case (ix) are  $\mathbf{Q}$ -equivalent to one of the following groups:*

$$G_{32} = \left\langle g_1 = \begin{pmatrix} 0 & 0 & 1 & 0 & 0 & 0 \\ 0 & 0 & 0 & 0 & 1 & 0 \\ 0 & 0 & 0 & 0 & 0 & 1 \\ 1 & 0 & -1 & 0 & 1 & 0 \\ 0 & 1 & -1 & 0 & 0 & 1 \\ 0 & 0 & 0 & 1 & -1 & 1 \end{pmatrix}, g_2 = \begin{pmatrix} -1 & 0 & 0 & 0 & 0 & 0 \\ 0 & 0 & 0 & 1 & 0 & 0 \\ 0 & 0 & 0 & 0 & 1 & 0 \\ 0 & 1 & 0 & 0 & 0 & 0 \\ 0 & 0 & 1 & 0 & 0 & 0 \\ 0 & 0 & 0 & 0 & 0 & 1 \end{pmatrix} \right\rangle,$$

$$G_{32} \cong S_5,$$

$$G_{33} = \left\langle D((1237)(46)), g_3 = \begin{pmatrix} 0 & 0 & 0 & 1 & -1 & 0 \\ 1 & 0 & 0 & 0 & -1 & 0 \\ 0 & 1 & 0 & 0 & -1 & 0 \\ 0 & 0 & 0 & 0 & -1 & 1 \\ 0 & 0 & 1 & 0 & -1 & 0 \\ 0 & 0 & 0 & 0 & -1 & 0 \end{pmatrix} \right\rangle, \quad G_{33} \cong PSL(2, 7).$$

**3. Computation of the Z-Classes.** The centerings of the groups  $G_i$  ( $i = 1, \dots, 33$ ) yield a set of representatives of the **Z**-classes of the natural representations of the  $G_i$  as we described in [7]. These representatives fix uniquely determined positive definite primitive integral quadratic forms  $F$ . At first, we list the matrices of all occurring forms. The **Z**-automorphs of these forms are the maximal finite irreducible subgroups of  $GL(6, \mathbf{Z})$ .

There are 17 forms  $F$ .  $J_n$  denotes the  $n \times n$  matrix with all entries equal to 1.

$$F_1 = I_6, \quad F_2 = \begin{pmatrix} 2 & 1 & 0 & 0 & 0 & 0 \\ 1 & 2 & 1 & 0 & 0 & 0 \\ 0 & 1 & 2 & 1 & 0 & 0 \\ 0 & 0 & 1 & 2 & 1 & 1 \\ 0 & 0 & 0 & 1 & 2 & 0 \\ 0 & 0 & 0 & 1 & 0 & 2 \end{pmatrix}, \quad F_3 = \begin{pmatrix} 2 & 0 & 0 & 0 & 0 & 1 \\ 0 & 2 & 0 & 0 & 0 & 1 \\ 0 & 0 & 2 & 0 & 0 & 1 \\ 0 & 0 & 0 & 2 & 0 & 1 \\ 0 & 0 & 0 & 0 & 2 & 1 \\ 1 & 1 & 1 & 1 & 1 & 3 \end{pmatrix},$$

$$F_4 = (I_3 + J_3) \dot{+} (I_3 + J_3), \quad F_5 = (4I_3 - J_3) \dot{+} (4I_3 - J_3),$$

$$F_6 = \begin{pmatrix} 3 & 1 & 1 & 1 & 1 & 1 \\ 1 & 3 & 1 & 1 & 1 & 1 \\ 1 & 1 & 3 & 1 & 1 & -1 \\ 1 & 1 & 1 & 3 & 1 & -1 \\ 1 & 1 & 1 & 1 & 3 & 1 \\ 1 & 1 & -1 & -1 & 1 & 3 \end{pmatrix}, \quad F_7 = \begin{pmatrix} 2 & -1 \\ -1 & 2 \end{pmatrix} \dot{+} \begin{pmatrix} 2 & -1 \\ -1 & 2 \end{pmatrix} \dot{+} \begin{pmatrix} 2 & -1 \\ -1 & 2 \end{pmatrix},$$

$$F_8 = \begin{pmatrix} 2 & 0 & -1 & 0 & 0 & 0 \\ 0 & 2 & 0 & -1 & 0 & 0 \\ -1 & 0 & 2 & -1 & 0 & 0 \\ 0 & -1 & -1 & 2 & -1 & 0 \\ 0 & 0 & 0 & -1 & 2 & -1 \\ 0 & 0 & 0 & 0 & -1 & 2 \end{pmatrix}, \quad F_9 = \begin{pmatrix} 4 & 1 & -2 & -2 & 1 & 1 \\ 1 & 4 & 1 & -2 & -2 & 1 \\ -2 & 1 & 4 & 1 & -2 & -2 \\ -2 & -2 & 1 & 4 & 1 & -2 \\ 1 & -2 & -2 & 1 & 4 & 1 \\ 1 & 1 & -2 & -2 & 1 & 4 \end{pmatrix},$$

$$F_{10} = \begin{pmatrix} 4 & 2 & 2 & -2 & 1 & 1 \\ 2 & 4 & 2 & 1 & -2 & 1 \\ 2 & 2 & 4 & 1 & 1 & -2 \\ -2 & 1 & 1 & 4 & 2 & 2 \\ 1 & -2 & 1 & 2 & 4 & 2 \\ 1 & 1 & -2 & 2 & 2 & 4 \end{pmatrix}, \quad F_{11} = \begin{pmatrix} 6 & -2 & -2 & -3 & 1 & 1 \\ -2 & 6 & -2 & 1 & -3 & 1 \\ -2 & -2 & 6 & 1 & 1 & -3 \\ -3 & 1 & 1 & 6 & -2 & -2 \\ 1 & -3 & 1 & -2 & 6 & -2 \\ 1 & 1 & -3 & -2 & -2 & 6 \end{pmatrix},$$

$$F_{12} = 7I_6 - J_6, \quad F_{13} = I_6 + J_6, \quad F_{14} = \begin{pmatrix} 4 & -1 & -2 & 1 & 1 & -2 \\ -1 & 4 & -1 & -2 & 1 & 1 \\ -2 & -1 & 4 & -1 & -2 & 1 \\ 1 & -2 & -1 & 4 & -1 & -2 \\ 1 & 1 & -2 & -1 & 4 & -1 \\ -2 & 1 & 1 & -2 & -1 & 4 \end{pmatrix},$$

$$F_{15} = \begin{pmatrix} 3 & -1 & -1 & 1 & 1 & 0 \\ -1 & 3 & -1 & -1 & 0 & 1 \\ -1 & -1 & 3 & 0 & -1 & -1 \\ 1 & -1 & 0 & 3 & -1 & 1 \\ 1 & 0 & -1 & -1 & 3 & -1 \\ 0 & 1 & -1 & 1 & -1 & 3 \end{pmatrix}, \quad F_{16} = \begin{pmatrix} 4 & 1 & 2 & 2 & 1 & 0 \\ 1 & 4 & 1 & 2 & 2 & 1 \\ 2 & 1 & 4 & 1 & 2 & -1 \\ 2 & 2 & 1 & 4 & 1 & -1 \\ 1 & 2 & 2 & 1 & 4 & 1 \\ 0 & 1 & -1 & -1 & 1 & 4 \end{pmatrix},$$

$$F_{17} = \begin{pmatrix} 5 & 1 & -1 & -1 & 1 & 2 \\ 1 & 5 & 1 & -1 & -1 & 2 \\ -1 & 1 & 5 & 1 & -1 & 2 \\ -1 & -1 & 1 & 5 & 1 & 2 \\ 1 & -1 & -1 & 1 & 5 & 2 \\ 2 & 2 & 2 & 2 & 2 & 5 \end{pmatrix}.$$

The determinants of  $F_1, \dots, F_{17}$  are  $1, 2^2, 2^4, 2^4, 2^8, 2^6, 3^3, 3, 3^5, 2^2 3^3, 2^4 3^3, 7^5, 7, 7^3, 5^3, 2^2 5^3, 2^4 5^3$ , respectively.

Now we give a description of the  $\prec$ -maximal centerings of the minimal irreducible groups  $G_i$  ( $i = 1, \dots, 33$ ). We start with the centerings of  $G_1, G_2, G_3$ . The numbers in brackets in front of the bases of the centerings are the numbers of the corresponding quadratic form  $F_i$ .

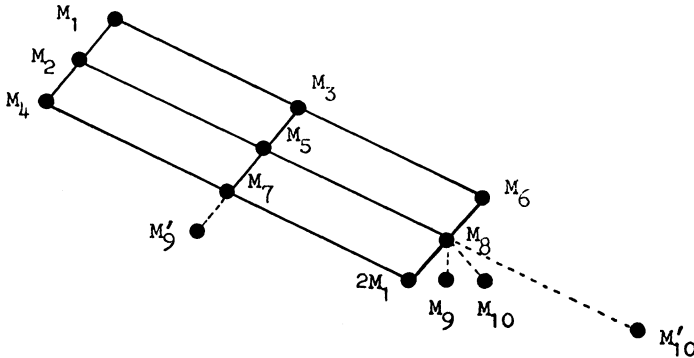

$G_1, G_2, G_3$  have the  $\prec$ -maximal centerings  $M_1, \dots, M_8$  in common. Beyond that the lattice of centerings of  $G_1$  contains  $M'_9, M'_{10}$ , that of  $G_2$  contains  $M_9, M_{10}$ . All occurring indices are powers of 2.

Bases of the centerings:

- (1)  $B(M_1) = I_6$ ,
- (2)  $B(M_2) = (x_1, h_1x_1, \dots, h_1^4x_1, y_1)$  with  $x_1^T = (1, 1, 0, 0, 0, 0)$ ,  $y_1^T = (0, 0, 0, 0, 1, -1)$ , and  $h_1 = D((123456))$ ,
- (4)  $B(M_4) = (x_2, h_2x_2, h_2^2x_2, y_2, h_2y_2, h_2^2y_2)$  with  $x_2^T = (1, 0, 1, 0, 0, 0)$ ,  $y_2^T = (0, 1, 0, 1, 0, 0)$ , and  $h_2 = D((135)(246))$ ,
- (1)  $B(M_5) = (x_3, h_2x_3, h_2^2x_3, y_3, h_2y_3, h_2^2y_3)$  with  $x_3^T = (1, 0, 0, 1, 0, 0)$ ,  $y_3^T = (-1, 0, 0, 1, 0, 0)$ ,
- (3)  $B(M_8) = (x_4, h_1x_4, \dots, h_1^4x_4, y_4)$  with  $x_4^T = (2, 0, 0, 0, 0, 0)$ ,  $y_4^T = (1, 1, 1, 1, 1, 1)$ ,
- (3)  $B(M_3) = \frac{1}{2}B(M_5)B(M_8)$ ,
- (2)  $B(M_7) = B(M_5)B(M_2)$ ,
- (5)  $B(M_6) = (x_5, h_2x_5, h_2^2x_5, y_5, h_2y_5, h_2^2y_5)$  with  $x_5^T = (-1, 0, 1, 0, 1, 0)$ ,  $y_5^T = (0, -1, 0, 1, 0, 1)$ ,
- (4)  $B(M'_9) = (x_6, h_1x_6, h_1^2x_6, y_6, h_1y_6, z_6)$  with  $x_6^T = (1, 1, 0, 1, 1, 0)$ ,  $y_6^T = (-1, -1, 0, 1, 1, 0)$ , and  $z_6^T = (-1, 0, -1, 1, 0, 1)$ ,
- (5)  $B(M'_{10}) = (x_7, h_1x_7, h_1^2x_7, y_7, h_2^2y_7, z_7)$  with  $x_7^T = (-1, 1, 1, -1, 1, 1)$ ,  $y_7^T = (-1, -1, 1, 1, 1, -1)$  and  $z_7^T = (1, -1, -1, -1, 1, -1)$ ,

(6) 
$$B(M_9) = \begin{pmatrix} 1 & -1 & -1 & -1 & -1 & 1 \\ 1 & -1 & 1 & 1 & 1 & -1 \\ 1 & 1 & -1 & 1 & 1 & 1 \\ 1 & 1 & 1 & -1 & 1 & 1 \\ 1 & 1 & 1 & 1 & -1 & -1 \\ 1 & 1 & 1 & 1 & 1 & 1 \end{pmatrix},$$

(6)  $B(M_{10}) = \text{diag}(-1, 1, 1, 1, 1, 1)B(M_9)$ .

We proceed to the  $\leftarrow$ -maximal centerings of  $G_4, \dots, G_8$ .

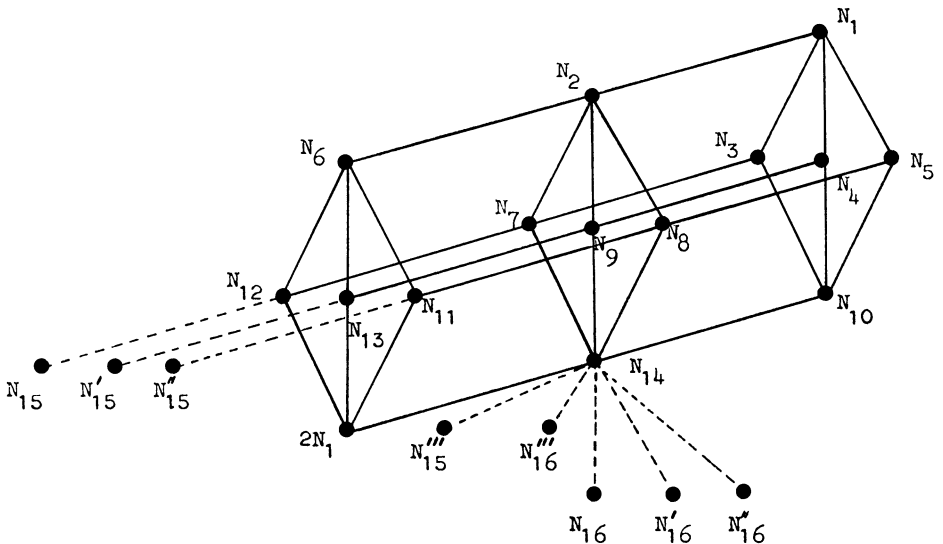

$G_4, \dots, G_8$  have the  $\prec$ -maximal centerings  $N_1, \dots, N_{14}$  in common. Furthermore, the lattice of centerings of  $G_4$  contains  $N_{15}, N_{16}$ , that of  $G_5$  contains  $N'_{15}, N'_{16}$ , that of  $G_6$  contains  $N''_{15}, N''_{16}$ , and that of  $G_7$  contains  $N'''_{15}, N'''_{16}$ . All occurring indices are powers of 2. Bases of the centerings:

- (1)  $B(N_1) = I_6, B(N_8) = B(M_5), B(N_7) = D((12)(34)(56))B(N_8), B(N_9) = D((165432))B(N_7),$
- (2)  $B(N_2) = B(M_2), B(N_{12}) = B(N_7)B(N_2), B(N_{13}) = B(N_9)B(N_2), B(N_{11}) = B(N_8)B(N_2),$
- (4)  $B(N_6) = B(M_4), B(N'_{15}) = B(M'_9), B(N_{15}) = D((12)(34)(56))B(N'_{15}), B(N'_{15}) = D((165432))B(N_{15}),$
- (3)  $B(N_{14}) = B(M_8), B(N_3) = \frac{1}{2}B(N_7)B(N_{14}), B(N_4) = \frac{1}{2}B(N_9)B(N_{14}), B(N_5) = \frac{1}{2}B(N_8)B(N_{14}),$
- (5)  $B(N_{10}) = B(M_6), B(N''_{16}) = B(M'_{10}), B(N_{16}) = D((12)(34)(56))B(N''_{16}), B(N'_{16}) = D((165432))B(N_{16}),$
- (6)  $B(N'''_{15}) = B(M_9), B(N'''_{16}) = B(M_{10}).$

We continue with the  $\prec$ -maximal centerings of  $G_9, \dots, G_{15}, G_{18}, \dots, G_{22}, G_{31}$ .

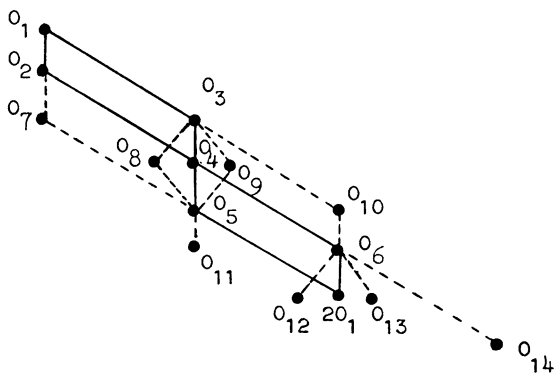

$G_9, \dots, G_{15}, G_{18}, \dots, G_{22}, G_{31}$  all have  $O_1, \dots, O_6$  as  $\prec$ -maximal centerings. Moreover, the lattices of centerings of  $G_9, \dots, G_{15}, G_{18}, G_{19}, G_{31}$  contain  $O_8, O_9$ , those of  $G_9, G_{18}, G_{31}$  contain  $O_{12}, O_{13}$ , those of  $G_{10}, G_{12}, G_{20}$  contain  $O_{11}, O_{14}$ . In addition, the lattice of centerings of  $G_{20}$  contains  $O_7$  and  $O_{10}$ . All occurring indices are powers of 2.

Bases of the centerings:

- (1)  $B(O_1) = I_6, B(O_4) = B(N_9),$
- (2)  $B(O_2) = B(M_2), B(O_5) = B(O_4)B(O_2),$
- (3)  $B(O_6) = B(M_8), B(O_3) = \frac{1}{2}B(O_4)B(O_6),$
- (4)  $B(O_7) = B(M_4), B(O_{11}) = B(N'_{15}),$
- (5)  $B(O_{10}) = B(M_6), B(O_{14}) = B(N'_{16}),$
- (6)  $B(O_{12}) = B(M_9), B(O_{13}) = B(M_{10}), B(O_8) = \frac{1}{2}B(O_4)B(O_{12}), B(O_9) = \frac{1}{2}B(O_4)B(O_{13}).$

The  $\prec$ -maximal centerings of  $G_{17}, G_{23}, G_{25}$ , and  $G_{26}$  follow.

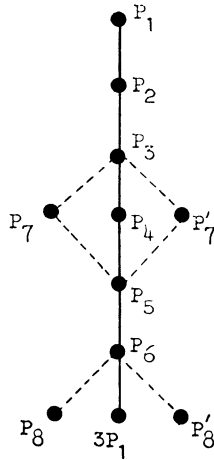

$G_{17}, G_{23}, G_{25}, G_{26}$  have the  $\triangleleft$ -maximal centerings  $P_1, \dots, P_6$  in common. Beyond that the lattices of centerings of  $G_{23}, G_{25}$  contain  $P_7, P_8$ , the lattice of centerings of  $G_{26}$  contains  $P'_7, P'_8$ . All occurring indices are powers of 3.

Bases of the centerings:

$$(7) \quad B(P_1) = I_6, \quad B(P_4) = \text{diag} \left( \begin{pmatrix} 2 & -1 \\ 1 & 1 \end{pmatrix}, \begin{pmatrix} 2 & -1 \\ 1 & 1 \end{pmatrix}, \begin{pmatrix} 2 & -1 \\ 1 & 1 \end{pmatrix} \right),$$

$$B(P_7) = \begin{pmatrix} 1 & 0 & 0 & -1 & 1 & -1 \\ 0 & 1 & 1 & -1 & 0 & -1 \\ 1 & 0 & -1 & 0 & -1 & 1 \\ 0 & 1 & -1 & 1 & -1 & 0 \\ 1 & 0 & 1 & 0 & 0 & 1 \\ 0 & 1 & 0 & 1 & 1 & 0 \end{pmatrix}, \quad B(P'_7) = \begin{pmatrix} 0 & 1 & -1 & 0 & 1 & -1 \\ 1 & 0 & -1 & 1 & 0 & -1 \\ 0 & 1 & 1 & -1 & -1 & 0 \\ 1 & 0 & 0 & -1 & -1 & 1 \\ 1 & -1 & 1 & -1 & 1 & -1 \\ 0 & -1 & 0 & -1 & 0 & -1 \end{pmatrix},$$

$$B(P_8) = B(P_4) \cdot B(P_7), \quad B(P'_8) = B(P_4)B(P'_7)$$

(9)  $B(P_2) = (x_8, h_3x_8, \dots, h_3^5x_8)$  with  $x_8^T = (0, 1, -1, 0, 0, 0)$  and  $h_3 = \text{diag}(\begin{pmatrix} 0 & -1 \\ 1 & -1 \end{pmatrix}, I_2, I_2)D((135)(246))$ ,

$$B(P_5) = B(P_4)B(P_2),$$

$$(8) \quad B(P_3) = \begin{pmatrix} 1 & 1 & 0 & -1 & 1 & -1 \\ 0 & 0 & 1 & 0 & 0 & -1 \\ 1 & 0 & -1 & 1 & -1 & 1 \\ 0 & 1 & -1 & 1 & -1 & 0 \\ 1 & 0 & 0 & 0 & -1 & 0 \\ 0 & 1 & 1 & -1 & -1 & 1 \end{pmatrix}, \quad B(P_6) = B(P_4)B(P_3).$$

The lattices of centerings of  $G_{28}, G_{29}, G_{30}$  are linearly ordered and consist of  $P_1, P_4$



in case of  $G_{28}$ ,  $G_{30}$  and of  $P_1, P_2, P_3, P_4$  in case of  $G_{29}$ . We proceed to the  $\leftarrow$ -maximal centerings of  $G_{24}$  and  $G_{27}$ .

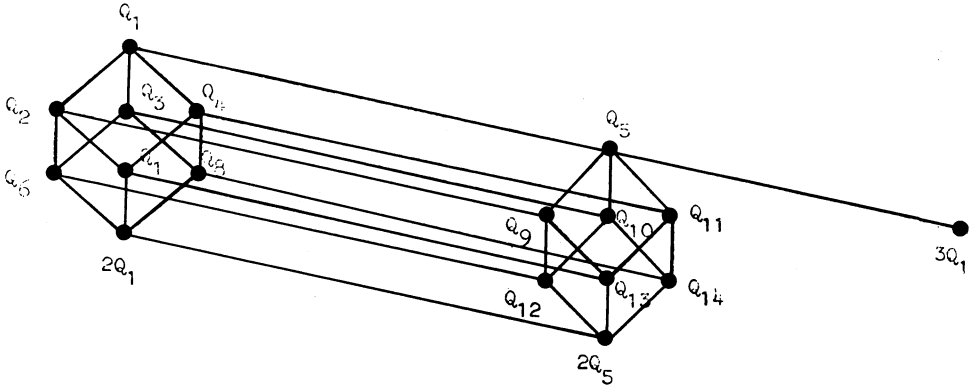

The  $\leftarrow$ -maximal centerings of  $G_{27}$  are  $Q_1, \dots, Q_{14}$ , those of  $G_{24}$  are  $Q_1, Q_2, Q_5, Q_8, Q_9, Q_{14}$ .

Bases of the centerings:

$$(7) \quad B(Q_1) = I_6, \quad B(Q_5) = B(P_4),$$

$$(10) \quad B(Q_2) = B(M_4), \quad B(Q_4) = \text{diag} \left( \begin{pmatrix} 0 & -1 \\ -1 & 0 \end{pmatrix}, \begin{pmatrix} 1 & -1 \\ 0 & -1 \end{pmatrix}, \begin{pmatrix} -1 & 0 \\ -1 & 1 \end{pmatrix} \right) B(Q_2),$$

$$B(Q_3) = \text{diag} \left( \begin{pmatrix} 1 & -1 \\ 0 & -1 \end{pmatrix}, \begin{pmatrix} 0 & 1 \\ 1 & 0 \end{pmatrix}, \begin{pmatrix} -1 & 0 \\ -1 & 1 \end{pmatrix} \right) B(Q_2), \quad B(Q_9) = B(Q_5)B(Q_2),$$

$$B(Q_{10}) = B(Q_5)B(Q_3), \quad B(Q_{11}) = B(Q_5)B(Q_4),$$

$$(11) \quad B(Q_8) = B(M_6), \quad B(Q_7) = \text{diag} \left( \begin{pmatrix} 1 & -1 \\ 0 & -1 \end{pmatrix}, \begin{pmatrix} 0 & 1 \\ 1 & 0 \end{pmatrix}, \begin{pmatrix} -1 & 1 \\ -1 & 1 \end{pmatrix} \right) B(Q_8),$$

$$B(Q_6) = \text{diag} \left( \begin{pmatrix} 0 & -1 \\ -1 & 0 \end{pmatrix}, \begin{pmatrix} 1 & -1 \\ 0 & -1 \end{pmatrix}, \begin{pmatrix} -1 & 0 \\ -1 & 1 \end{pmatrix} \right) B(Q_8),$$

$$B(Q_{12}) = B(Q_5)B(Q_6), \quad B(Q_{13}) = B(Q_5)B(Q_7), \quad B(Q_{14}) = B(Q_5)B(Q_8).$$

The lattice of centerings of  $G_{16}$  is linearly ordered. We denote the  $\leftarrow$ -maximal centerings by  $R_1, \dots, R_6$  ( $R_i \subseteq R_{i-1}$  and  $R_{i-1} : R_i = 7$  for  $i = 2, \dots, 6$ ).

Bases of the centerings:

(12)  $B(R_1) = I_6$ ,  $B(R_4) = (x_9, h_4 x_9, \dots, h_4^5 x_9)$  with  $x_9^T = (1, 1, -1, 1, -1, -1)$  and  $h_4$  is the element  $g_1$  in the definition of  $G_{16}$  in Lemma (2.3).

$$(13) \quad B(R_2) = I_6 + J_6, \quad B(R_5) = B(R_4)B(R_2),$$

$$(14) B(R_3) = \begin{pmatrix} 1 & -1 & 0 & 0 & -1 & -1 \\ -1 & 1 & 1 & -2 & -1 & 1 \\ 0 & 0 & -1 & -1 & 0 & 1 \\ 0 & 1 & -1 & -1 & 1 & -1 \\ -1 & -1 & 1 & -1 & 0 & 0 \\ 1 & 0 & 0 & -2 & 1 & 0 \end{pmatrix}, \quad B(R_6) = \begin{pmatrix} 3 & 4 & -5 & -3 & 3 & -1 \\ -1 & 1 & -3 & 1 & -1 & -2 \\ 2 & -2 & -1 & -2 & 2 & -3 \\ -2 & 2 & 1 & -5 & -2 & 3 \\ 1 & -1 & -4 & -1 & 1 & 2 \\ -3 & 3 & -2 & -4 & 4 & 1 \end{pmatrix}$$

The  $\prec$ -maximal centerings of  $G_{33}$  are  $S_1, \dots, S_4$ :

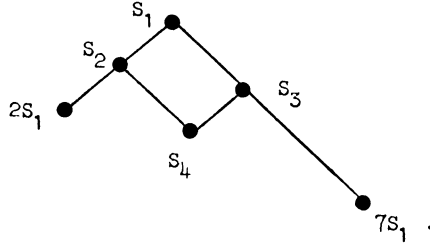

Bases of the centerings:

(12)  $B(S_1) = I_6, B(S_2) = (x_{10}, h_5 x_{10}, \dots, h_5^5 x_{10})$  with  $x_{10}^T = (1, 0, 1, 0, 1, 0)$  and  $h_5 = g_3$  in the definition of  $G_{33}$  in Lemma (2.11),

(13)  $B(S_3) = B(R_2), B(S_4) = B(S_2)B(S_3)$ .

Finally the  $\prec$ -maximal centerings of  $G_{32}$  are:

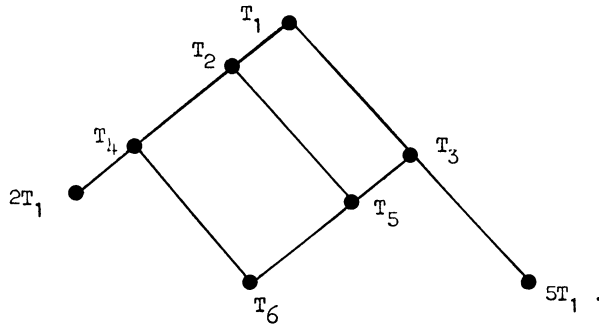

Bases of the centerings:

$$(15) \quad B(T_1) = I_6, \quad B(T_3) = \begin{pmatrix} 3 & 1 & 1 & -1 & -1 & 0 \\ 1 & 3 & 1 & 1 & 0 & -1 \\ 1 & 1 & 3 & 0 & 1 & 1 \\ -1 & 1 & 0 & 3 & 1 & -1 \\ -1 & 0 & 1 & 1 & 3 & 1 \\ 0 & -1 & 1 & -1 & 1 & 3 \end{pmatrix},$$

$$(16) \quad B(T_2) = \begin{pmatrix} 1 & 0 & 0 & 0 & 0 & 1 \\ 1 & 0 & 1 & 0 & 1 & 0 \\ 0 & 0 & 0 & 0 & 1 & 1 \\ 0 & 1 & 1 & 0 & 1 & 0 \\ 0 & 1 & 0 & 1 & 0 & 0 \\ 0 & 0 & 0 & 1 & 0 & 0 \end{pmatrix}, \quad B(T_5) = B(T_3)B(T_2),$$

$$(17) \quad B(T_4) = \begin{pmatrix} -1 & 1 & 1 & 1 & -1 & 1 \\ 1 & 1 & 1 & 1 & -1 & 1 \\ 1 & 1 & 1 & -1 & -1 & 1 \\ 1 & -1 & 1 & 1 & 1 & 1 \\ 1 & 1 & 1 & -1 & 1 & 1 \\ 1 & 1 & -1 & -1 & 1 & 1 \end{pmatrix}, \quad B(T_6) = B(T_3)B(T_4).$$

**4. The Irreducible Maximal Finite Subgroups of  $GL(6, \mathbf{Z})$ .** If  $L$  is an irreducible  $\mathbf{Z}G$ -representation module and  $M$  a  $\prec$ -maximal centering of  $L$ , then  $M^\#$  denotes the unique  $\prec$ -maximal centering of  $L$ , which belongs to the inverse transposed representation coming from  $M$  [7]. By Theorem (6.1) in [7] we know that an irreducible maximal finite subgroup  $G$  of  $GL(n, \mathbf{Z})$  with form  $X$  yields another maximal finite subgroup  $G^\#$  fixing the form  $X^{-1}$ .  $G$  and  $G^\#$  are  $\mathbf{Q}$ -equivalent.

For the centerings  $M_i, \dots, T_i$  in the last section the  $M_i^\#, \dots, T_i^\#$  are easily derived.

$$M_1^\# = M_1, M_2^\# = M_8, M_4^\# = M_6, M_5^\# = M_5, M_3^\# = M_7, M_9^\# = M'_{10}, M_9^\# = M_{10}.$$

$$N_1^\# = N_1, N_2^\# = N_{14}, N_3^\# = N_{12}, N_4^\# = N_{13}, N_5^\# = N_{11}, N_6^\# = N_{10},$$

$$N_7^\# = N_7, N_8^\# = N_8,$$

$$N_9^\# = N_9, N_{15}^\# = N_{16}, N_{15}^\# = N'_{16}, N_{15}^\# = N''_{16}, N_{15}^\# = N'''_{16}.$$

$$O_1^\# = O_1, O_2^\# = O_6, O_3^\# = O_5, O_4^\# = O_4, O_7^\# = O_{10}, O_8^\# = O_9,$$

$$O_{11}^\# = O_{14}, O_{12}^\# = O_{13}.$$

$$P_1^\# = P_4, P_2^\# = P_3, P_5^\# = P_6, P_7^\# = P_8, P_7^\# = P'_8.$$

$$Q_1^\# = Q_5, Q_2^\# = Q_{14}, Q_3^\# = Q_{13}, Q_4^\# = Q_{12}, Q_6^\# = Q_{11}, Q_7^\# = Q_{10}, Q_8^\# = Q_9.$$

$$R_1^\# = R_2, R_3^\# = R_6, R_4^\# = R_5.$$

$$S_1^\# = S_3, S_2^\# = S_4.$$

$$T_1^\# = T_3, T_2^\# = T_6, T_4^\# = T_5.$$

From this we conclude immediately that the automorphism groups of  $F_2$  and  $F_3$ , of  $F_4$  and  $F_5$ , of  $F_8$  and  $F_9$ , of  $F_{10}$  and  $F_{11}$ , of  $F_{12}$  and  $F_{13}$ , and of  $F_{16}$  and  $F_{17}$  are rationally equivalent.

(4.1) THEOREM. *The  $\mathbf{Z}$ -automorphs of the forms  $F_1, \dots, F_{17}$  defined at the beginning of Section 3 are a full set of representatives for the  $\mathbf{Z}$ -classes of the maximal finite subgroups of  $GL(6, \mathbf{Z})$ .*

(i)  $\text{Aut}(F_1), \text{Aut}(F_2),$  and  $\text{Aut}(F_3)$  are  $\mathbf{Q}$ -equivalent. They are isomorphic to the wreath product  $C_2 \sim S_6$  of order  $2^6 6!$  ( $\text{Aut}(F_1) = H_6$ ).

(ii)  $\text{Aut}(F_4) \sim_{\mathbf{Q}} \text{Aut } F_5$ . Both are isomorphic to the wreath product  $(C_2 \sim S_3) \sim C_2 \cong (C_2 \times S_4) \sim C_2$  of order  $(2^3 3!)^2 2$ .

(iii)  $\text{Aut}(F_6)$  is  $\mathbf{Q}$ -equivalent to the subgroup of the full monomial group  $H_6$  generated by the diagonal matrices of even trace and all permutation matrices. Its order is  $2^5 6!$ .

(iv)  $\text{Aut}(F_7)$  is isomorphic to the wreath product  $(C_2 \times S_3) \sim S_3$  of order  $(2 \cdot 3!)^3 3!$ .

(v)  $\text{Aut}(F_8) \sim_{\mathbf{Q}} \text{Aut}(F_9)$ .  $\text{Aut}(F_8)$  is the direct product of  $\langle -I_6 \rangle$  and the Weyl group of the root system  $E_6$ . Its order is  $2^8 3^4 5$ .

(vi)  $\text{Aut}(F_{10}) \sim_{\mathbf{Q}} \text{Aut}(F_{11})$ . They are isomorphic to the direct product  $S_3 \times S_4 \times C_2$  of order  $3!4!2$ .

(vii)  $\text{Aut}(F_{12}) \sim_{\mathbf{Q}} \text{Aut}(F_{13})$ . Both are isomorphic to  $C_2 \times S_7$  of order  $2 \cdot 7!$ .

(viii)  $\text{Aut}(F_{14})$  is isomorphic to  $C_2 \times PGL(2, 7)$  of order  $2 \cdot 336$ .

(ix)  $\text{Aut}(F_{15}), \text{Aut}(F_{16})$  and  $\text{Aut}(F_{17})$  are  $\mathbf{Q}$ -equivalent. They are isomorphic to  $C_2 \times S_5$  of order  $2 \cdot 5!$ .

*Proof.*

Ad (i). Compare Theorem (6.1) in [7] or, for a more general result, (III. 6) in [8].

Ad (ii). This follows from the main theorem in [2] and the well-known fact that the  $\mathbf{Z}$ -automorphs of  $I_3 + J_3$  and  $4I_3 - J_3$  are  $\mathbf{Q}$ -equivalent to the  $\mathbf{Z}$ -automorph  $H_3$  of  $I_3$ .

Ad (iii). We consider all vectors of shortest length in the centering  $M_9$  (compare Section 3), which has this form  $F_6$ . Their coordinates are all equal to  $\pm 1$  with an even number of minus ones. The subgroup of  $H_6$  described in the theorem operates on the set of these vectors. This already yields the whole automorph, since there are no other permutations of the vectors of shortest length respecting the scalar product, which follows from elementary considerations.

Ad (iv). The same argument as in (ii) holds.

Ad (v). The form  $F_8$  can also be derived from the root system  $E_6$  [4, p. 66], and the automorph of  $F_8$  is equal to the automorphism group of the root system, in this case  $W(E_6) \times (-I_6)$ .

Ad (vi). We have  $F_{11} = (3I_2 - J_2) \otimes (4I_3 - J_3)$ . So  $\text{Aut}(F_{11})$  has a subgroup  $H$  consisting of the elements  $g \otimes h$  with  $g \in \text{Aut}(3I_2 - J_2)$  and  $h \in \text{Aut}(4I_3 - J_3)$ .  $H$  is isomorphic to  $(S_3 \times S_4) \times C_2$ . (Note  $\text{Aut}(3I_2 - J_2) \cong S_3 \times C_2$  and  $\text{Aut}(4I_3 - J_3) \cong S_4 \times C_2$ .) That  $H$  is already equal to  $\text{Aut}(F_{11})$  can be proved as follows. The lattice corresponding to  $F_{11}$  has 12 vectors of shortest length (up to sign) and  $H$  acts transitively on these 24 vectors. Let  $x$  be one of these shortest vectors. Then the stabilizer of  $x$  in  $\text{Aut}(F_{11})$  has a faithful permutation representation on the vectors of

shortest length whose scalar product with  $x$  is equal to 1, because these are six linearly independent vectors. Considering the scalar products one easily sees that the order of the stabilizer is  $6 \cdot 2$ .

Ad (vii). This proof is similar to the one of Theorem (6.3) in [7]. For a more general result see (III. 3) in [8]. Note the vectors of shortest length in  $R_1$  are up to sign the unit vectors and the negative sum of these.

Ad (viii).  $\text{Aut}(F_{14})$  contains a subgroup which is  $\mathbb{Q}$ -equivalent to  $G_{16}$ . Let  $s$  be the number of the 7-Sylow groups in  $\text{Aut}(F_{14})$ . From the definition of  $G_{16}$  one sees easily that the normalizer of the subgroup corresponding to  $G_{16}$  in  $\text{Aut}(F_{14})$  is of order  $7 \cdot 6 \cdot 2$ . Let  $|\text{Aut}(F_{14})| = 2^\alpha 3^\beta 5^\gamma 7^\delta$  ( $\alpha, \beta, \gamma, \delta \in \mathbb{Z}^{\geq 0}$ ;  $\alpha \leq 10, \beta \leq 4, \gamma \leq 1, \delta \leq 1$  by [6]). Then  $\delta = 1, \alpha \geq 2, \beta \geq 1$  and  $2^{\alpha-2} 3^{\beta-1} 5^\gamma \equiv 1 \pmod{7}$  by Sylow's Theorem. On the other hand there are up to sign 21 vectors of shortest length in the centering  $R_3$  belonging to the form  $F_{14}$ . The subgroup of  $\text{Aut}(F_{14})$  which is  $\mathbb{Q}$ -equivalent to  $G_{16}$  already operates transitively on these vectors. Let  $x$  be one of the vectors of shortest length. Then there are exactly four vectors of shortest length (up to sign) which are orthogonal to  $x$ . These are linearly independent. Hence the stabilizer of  $x$  in  $\text{Aut}(F_{14})$  has a monomial representation of degree 4, where the kernel is at most of order 2; hence  $\gamma = 0$ . Considering the values of the scalar products of the four vectors one sees, that the order of the stabilizer of  $x$  cannot be divisible by 3 and that the order must divide  $2^4$ . So the order of  $\text{Aut}(F_{14})$  is  $2 \cdot 21 \cdot 2^{\alpha-1}$  with  $\alpha \leq 5$ . Considering the congruence  $2^{\alpha-2} \equiv 1 \pmod{7}$  we get the solutions  $\alpha_1 = 2$  and  $\alpha_2 = 5$ . One easily finds a permutation of the vectors of shortest length fixing  $x$  and respecting the scalar product which is not induced by an element of  $G_{16}$  and therefore  $\alpha = 5$  holds. Also the action is primitive. But 21 is no prime power. So  $\text{Aut}(F_{14})$  has to be nonsolvable and our assertion follows, as the center of  $\text{Aut}(F_{14})$  must have order 2.

Ad (ix). There are 10 vectors of shortest length in  $T_1$  (up to sign). An easy computation yields that  $\text{Aut}(F_{15})$  is isomorphic to  $C_2 \times S_5$ . (Note  $G_{32}$  is already isomorphic to  $S_5$ .) To complete the proof it suffices to show  $\text{Aut}(F_{17}) \sim_{\mathbb{Q}} \text{Aut}(F_{15})$ . This can be done as in the proof of Theorem (6.2) in [7] by observing that the vectors of length 12 (respectively 6 if the primitive form belonging to  $T_4$  is taken) are already contained in  $2T_1$ . Q.E.D.

In the discussion of case (ix) in Section 2 we did not prove the following two assertions:

If  $G \leq GL(6, \mathbb{Z})$  is irreducible and

(1)  $G \cap SL(6, \mathbb{Z}) \cong PSL(2, 7)$  or

(2)  $G \cong PSU_4(2)$ ,

then  $G$  is not minimal irreducible.

This follows now easily from the proof of Theorem (4.1) (viii) or (4.1) (v), respectively.

Mathematisches Institut der Universität zu Köln  
Weyertal 86–90  
5 Köln 41, West Germany

1. H. F. BLICHFELDT, *Finite Collineation Groups*, Univ. of Chicago Press, Chicago, 1917.
2. E. C. DADE, "Integral systems of imprimitivity," *Math. Ann.*, v. 154, 1964, pp. 383–386. MR 28 #5123.
3. V. ENNOLA, "On the characters of the finite unitary groups," *Ann. Acad. Sci. Fenn. Ser. A I*, no. 323, Helsinki, 1963. MR 28 #143.
4. J. E. HUMPHREYS, *Introduction to Lie Algebras and Representation Theory*, Graduate Texts in Math., vol. 9, Springer-Verlag, Berlin and New York, 1972. MR 48 #2197.
5. J. H. LINDSEY II, "Finite linear groups of degree six," *Canad. J. Math.*, v. 23, 1971, pp. 771–790. MR 44 #6853.
6. H. MINKOWSKI, "Zur Theorie der positiven quadratischen Formen," *Gesammelte Werke*, Band 1, Chelsea, New York, 1958, pp. 212–218.
7. W. PLESKEN & M. POHST, "On maximal finite irreducible subgroups of  $GL(n, \mathbb{Z})$ . I. The five and seven dimensional cases," *Math. Comp.*, this issue, pp. 536–551.
8. W. PLESKEN, *Beiträge zur Bestimmung der endlichen irreduziblen Untergruppen von  $GL(n, \mathbb{Z})$  und ihrer ganzzahligen Darstellungen*, Dissertation, Aachen, 1974.
9. I. SCHUR, "Untersuchungen über die Darstellung der endlichen Gruppen durch gebrochene lineare Substitutionen," *Gesammelte Abhandlungen*, Band 1, Springer-Verlag, Berlin and New York, 1973, pp. 198–250.
10. I. SCHUR, "Über die Darstellung der symmetrischen und der alternierenden Gruppe durch gebrochene lineare Substitutionen," *Gesammelte Abhandlungen*, Band 1, Springer-Verlag, Berlin and New York, 1973, pp. 346–441.
11. O. TAUSSKY, "On a theorem of Latimer and MacDuffee," *Canad. J. Math.*, v. 1, 1949, pp. 300–302. MR 11, 3.