

CALCULATION OF VALUES OF L -FUNCTIONS ASSOCIATED TO ELLIPTIC CURVES

SHIGEKI AKIYAMA AND YOSHIO TANIGAWA

ABSTRACT. We calculated numerically the values of L -functions of four typical elliptic curves in the critical strip in the range $\text{Im}(s) \leq 400$. We found that all the non-trivial zeros in this range lie on the critical line $\text{Re}(s) = 1$ and are simple except the one at $s = 1$. The method we employed in this paper is the approximate functional equation with incomplete gamma functions in the coefficients. For incomplete gamma functions, we continued them holomorphically to the right half plane $\text{Re}(s) > 0$, which enables us to calculate for large $\text{Im}(s)$. Furthermore we remark that a relation exists between Sato-Tate conjecture and the generalized Riemann Hypothesis.

1. INTRODUCTION AND THE STATEMENT OF RESULTS

The numerical calculations of the Riemann zeta function $\zeta(s)$ have a long history. In the critical strip, the Euler-Maclaurin summation formula is applicable, but on the critical line, the famous Riemann-Siegel formula is useful because it is very fast and accurate (see [3] or [8]). Using these formulas, it is known at present that the Riemann Hypothesis holds for $\text{Im}(s)$ less than about 1.5×10^9 (see J. van de Lune, H. J. J. te Riele and D. T. Winter [13]; see also Odlyzko [16]). By the Euler-Maclaurin summation formula, we can also calculate the values of the Hurwitz zeta function and hence the values of the Dirichlet L -function because it is a finite sum of the Hurwitz zeta functions.

For other L -functions, we have the examples of Manin [14], [15], Yoshida [24], [25] and Fermigier [4]. In his papers, Manin developed the theory of modular symbols and applied his theory to the calculation of Fourier coefficients of cusp forms of weight 2 and the value at 1 of the corresponding Dirichlet series. In fact, four examples of modular curves were treated in [15]. See Cremona [1] for other examples.

Yoshida and Fermigier calculated the values of the L -function on the critical line. Yoshida makes use of the iteration of partial summations in order to access the speed of convergence of the Dirichlet series. He said that his method “may seem to be only speculative” (p. 89 in [24]) and “on heuristic grounds” (p. 91 in [24]), though he made some discussions on the confidence of his data. He found zeros of many L -functions, namely, the L -function associated with the Ramanujan function $\Delta(z)$, the symmetric j -th power L -functions of $\Delta(z)$ for $j = 2, 3$ and 4, L -functions associated to cusp forms, L -functions associated to Hecke characters of

Received by the editor May 22, 1996 and, in revised form, December 11, 1996.

1991 *Mathematics Subject Classification.* Primary 11F11, 11G40, 11M26.

Key words and phrases. Elliptic curve, L -function, approximate functional equation, Sato-Tate conjecture, Riemann Hypothesis.

real quadratic fields and Artin's L -functions. He also observed that the generalized Riemann Hypothesis is true for $L(s, \Delta)$ in $0 \leq \text{Im}(s) \leq 100$.

On the other hand, Fermigier used an expression of an L -function by the Dirichlet series with incomplete gamma functions in the coefficients. He employed the Romberg integration method for the calculation of incomplete gamma functions. He calculated the zeros of $L(1 + it, E)$ in $0 \leq t \leq 15$ for all the elliptic curves of prime conductor $N \leq 13100$. He also observed that the generalized Riemann Hypothesis is true for these $L(s, E)$ in $0 \leq \text{Im}(s) \leq 15$.

The aim of this paper is to show a method and some examples for larger $\text{Im}(s)$ than theirs. As in Fermigier [4], we use an expression of an L -function with the incomplete gamma function $\Gamma(s, z)$. However, the second variable z is real in his case, so it seems somewhat difficult to calculate when $\text{Im}(s)$ is large because the necessary increase in the memory bank of a machine is of exponential order with respect to $\text{Im}(s)$. We continue the incomplete gamma function in the right half plane $\text{Re}(s) > 0$. After this, the increase is of polynomial order, hence we can calculate the value numerically for rather large $\text{Im}(s)$. See the paragraphs after Theorem 1 below. After the analytic continuation, we expand it to the continued fraction. Using this method, we calculated the values of $L(1 + it, E)$ for four typical examples of elliptic curves in the range $0 \leq t \leq 400$, and checked that the generalized Riemann Hypothesis holds in this range.

We also present some graphs drawn by plotting the values of an L -function on the Gaussian plane. Since $L(s, E)$ has a functional equation, we can easily determine the argument of $L(s, E)$ on the critical line. So one may think that the essential thing is the absolute value, and such graph is meaningless. But the authors believe that such a visualization gives us the beauty and sense of the Riemann Hypothesis.

To state Theorem 1, we shall recall the definition of the L -function associated to an elliptic curve. Let E be an elliptic curve given by the global minimal Weierstrass equation

$$y^2 + A_1xy + A_3y = x^3 + A_2x^2 + A_4x + A_6,$$

and let Δ be its discriminant. For each prime p , we put

$$a_p = p + 1 - \#E_p(\mathbf{Z}/p\mathbf{Z}),$$

where E_p is the reduction modulo p . If $p|\Delta$, then E_p has a singularity and

$$a_p = \begin{cases} 0 & \text{for the case of a cusp,} \\ 1 & \text{for the case of a split node,} \\ -1 & \text{for the case of a non-split node.} \end{cases}$$

If $p \nmid \Delta$, then we have

$$(1) \quad |a_p| \leq 2\sqrt{p}$$

(Hasse's theorem). The L -function associated to E is defined by

$$L(s, E) = \prod_{p|\Delta} \frac{1}{1 - a_p p^{-s}} \prod_{p \nmid \Delta} \frac{1}{1 - a_p p^{-s} + p^{1-2s}}.$$

This infinite product is absolutely convergent for $\text{Re } s > 3/2$ by (1), and there we can expand it into the Dirichlet series $L(s, E) = \sum_{n=1}^{\infty} a_n n^{-s}$.

Assume that E has a modular parametrization of level N . In the recent works of Wiles [23], Taylor and Wiles [19] and Diamond [2], it was proved that any elliptic

curve which has semi-stable good reduction at 3 and 5 is modular. All the curves we treat in Section 5 satisfy this assumption. Let

$$f_E(z) = \sum_{n=1}^{\infty} a_n e^{2\pi i n z},$$

then by Eichler-Shimura's theory, $f_E(z)$ is a primitive form of weight 2 with respect to $\Gamma_0(N)$. Furthermore we have

$$f_E\left(-\frac{1}{Nz}\right) = \mu N z^2 f_E(z) \quad (\mu = \pm 1).$$

Now, $L(s, E)$ can be continued holomorphically to the whole complex plane and satisfies the functional equation:

$$N^{s/2} (2\pi)^{-s} \Gamma(s) L(s, E) = -\mu N^{(2-s)/2} (2\pi)^{-(2-s)} \Gamma(2-s) L(2-s, E).$$

The readers may refer to Knapp [10] for these subjects.

Then our first theorem is

Theorem 1. *Let $s = \sigma + it$ be a complex number such that $1/2 \leq \sigma \leq 3/2$ and $t > 0$ and let $\Gamma(s, z)$ be the incomplete gamma function of the second kind. We take a positive integer M satisfying $M > t\sqrt{N}/4$, and put $r = e^{i(\pi/2 - \delta(t))}$, where $\delta(t)$ is a function of t with $0 < \delta(t) \leq \pi/2$. Then we have*

$$\begin{aligned} L(s, E) &= \frac{1}{\Gamma(s)} \sum_{n \leq M} \frac{a_n}{n^s} \Gamma\left(s, \frac{2\pi n r}{\sqrt{N}}\right) \\ (2) \quad &- \frac{\mu N^{1-s} (2\pi)^{2(s-1)}}{\Gamma(s)} \sum_{n \leq M} \frac{a_n}{n^{2-s}} \Gamma\left(2-s, \frac{2\pi n}{\sqrt{N}r}\right) \\ &+ (2\pi)^s \Gamma(s)^{-1} R, \end{aligned}$$

where the last term R satisfies the inequality

$$\begin{aligned} (3) \quad |R| &< e^{-\pi t/2} e^{\delta(t)(t-4M/\sqrt{N})} N^{(1-\sigma)/2} \sqrt{M} \delta(t)^{-1} \\ &\times \left\{ 1 + \frac{\log M + \sigma + 1}{2t\delta(t)} + \frac{(\sigma - 1)(\log M + 2)}{4(t\delta(t))^2} \right\}. \end{aligned}$$

The proof will be given in Section 2.

The incomplete gamma function of the second kind is defined by

$$(4) \quad \Gamma(s, z) = \int_z^{\infty} e^{-t} t^{s-1} dt \quad (z \in \mathbf{R}, \operatorname{Re}(s) > 0).$$

(Note that this integral is denoted by $\Gamma(z, s)$ in Fermigier [4].) Following Lavrik [12], Karatsuba [9] and Turganaliyev [21], we continue the function $\Gamma(s, z)$ holomorphically to the right half plane $\operatorname{Re}(z) > 0$ by making a change of variable $t \rightarrow zt$ and rotating the line of integration by the angle $\arg z$. Then we have

$$(5) \quad \Gamma(s, z) = z^s \int_1^{\infty} e^{-zt} t^{s-1} dt$$

and, when $\operatorname{Re}(s)$ is bounded and $\operatorname{Re}(z) > c$ for some positive constant c ,

$$(6) \quad |\Gamma(s, z)| \ll |z^s|$$

uniformly in s and z .

The inequality (3) shows that when $\delta(t)$ is small, we must take large M to get the accuracy of data. Hence, $\delta(t) = \pi/2$ (this means $r = 1$) is the most efficient choice for calculations theoretically. But, for a technical reason, we have to choose the function $\delta(t) < \pi/2$. The function of the form $\Gamma(s, z)/\Gamma(s)$ appears in the right hand side of (2). Since $\Gamma(s)$ is of exponential decay when $|t| \rightarrow \infty$, the absolute value of each term in the sum may be very large. In fact, if $r = 1$ and t is large, each term in (2) is a huge number and it becomes impossible to compute it. In order to avoid this difficulty, we put $r = e^{i(\pi/2 - \delta(t))}$ and $\delta(t) < \pi/2$. Then from (6),

$$|\Gamma(s, Ar)| \ll A^\sigma e^{-(\frac{\pi}{2} - \delta(t))t},$$

(where A is independent of t), hence the factor $e^{-\pi t/2}$ cancels the one arising from the denominator. For example, if $\delta(t) \sim 1/t$, $\Gamma(s, Ar)/\Gamma(s)$ has a polynomial order as $|t| \rightarrow \infty$, hence we can put the calculations in practice. Turganaliyev [21] put $\delta(t) = 1/(1+t)$. We choose $\delta(t) = \pi/2$ for small t , $\delta(t) = 1/(1 + \log^2 t)$ for a little larger t and $\delta(t) = 1/(1+t)$ otherwise.

The estimation (3) does not make sense when t is very close to 0. But, in this case, we set $\delta(t) = \pi/2$ and can get the explicit estimation from (16).

Our method is applicable to the Dirichlet series with an appropriate functional equation. Explicit estimation of the coefficients is needed to get the concrete upper bound of the error term. For example, we can treat the Dedekind zeta function or the Hecke L -function of a cusp form.

Now we shall state the next theorem. Let E be an elliptic curve defined over \mathbf{Q} without complex multiplication. Define $\theta_p \in (0, \pi)$ by $a_p = 2\sqrt{p} \cos(\theta_p)$. Let p_n be the n -th prime number, and consider the real sequence $x_n = \theta_{p_n}/\pi$, ($n = 1, 2, \dots$). Let g be a real valued strictly increasing function on the interval $[0, 1]$ with $g(0) = 0$ and $g(1) = 1$. Define the discrepancy with respect to the distribution function g by

$$(7) \quad D_K^{(g)}(x_n) = \sup_{0 \leq \alpha \leq 1} \left| \frac{A([0, \alpha], (x_n), K)}{K} - g(\alpha) \right|,$$

where

$$A([0, \alpha], (x_n), K) = \#\{x_n \in [0, \alpha] ; 1 \leq n \leq K\}.$$

Put

$$ST(x) = x - \frac{\sin(2\pi x)}{2\pi}.$$

We call $D_K^{(ST)}$ the discrepancy with respect to the Sato-Tate measure. The Sato-Tate conjecture asserts that $\lim_{K \rightarrow \infty} D_K^{(ST)}(x_n) = 0$, which is easily shown to be equivalent to

$$\frac{\#\{\theta_p \in [\alpha, \beta] ; p \leq X\}}{\#\{p ; p \leq X\}} \rightarrow \frac{2}{\pi} \int_\alpha^\beta \sin^2(t) dt,$$

for any $0 \leq \alpha \leq \beta \leq \pi$. See Ogg [17] or Shahidi [18] for the Sato-Tate conjecture. Here we propose a quantitative version of their conjecture.

Conjecture 1. For any positive ε , $D_K^{(ST)}(x_n) = O(K^{-1/2+\varepsilon})$.

Then our second theorem is

Theorem 2. *Let E be an elliptic curve defined over \mathbf{Q} which has no complex multiplication. Then the above Conjecture implies the truth of the generalized Riemann Hypothesis for $L(s, E)$.*

The proof of Theorem 2 will be given in Section 3.

In Section 5, we show numerical experiments on Conjecture 1 for some elliptic curves. These seem to support the validity of Conjecture 1.

2. APPROXIMATE FUNCTIONAL EQUATION

Let $f(z)$ be a cusp form of weight k with respect to $\Gamma_0(N)$, and let $f(z) = \sum_{n=1}^{\infty} a_n e^{2\pi i n z}$ be the Fourier expansion at the cusp ∞ . Furthermore we assume that $f(z)$ is an eigenfunction of the involution

$$f \rightarrow f \Big|_k \begin{pmatrix} 0 & -1 \\ N & 0 \end{pmatrix}$$

with eigenvalue $\mu = \pm 1$; namely,

$$(8) \quad f\left(-\frac{1}{Nz}\right) = \mu N^{k/2} z^k f(z).$$

Let $L(s, f)$ be the Dirichlet series defined by $L(s, f) = \sum_{n=1}^{\infty} a_n n^{-s}$. Since $a_n = O(n^{\frac{k-1}{2} + \varepsilon})$ by Deligne's theorem, $L(s, f)$ converges absolutely for $\text{Re } s > (k + 1)/2$. It is well known that the function $\Lambda(s, f) := N^{s/2} (2\pi)^{-s} \Gamma(s) L(s, f)$ is an entire function of s and satisfies the functional equation

$$(9) \quad \Lambda(s, f) = \mu i^k \Lambda(k - s, f).$$

By modifying the standard proof of (9), we get the approximate functional equation with incomplete gamma functions. Let $I(s)$ be the function defined by

$$I(s) = \int_0^{\infty} y^{s-1} f(iy) dy,$$

which is equal to $(2\pi)^{-s} \Gamma(s) L(s, f)$ for $\text{Re } s > (k + 1)/2$. Let r be a complex number with $\text{Re}(r) > 0$, and divide the integral of $I(s)$ as

$$I(s) = \int_0^{\frac{r}{\sqrt{N}}} y^{s-1} f(iy) dy = \int_0^{\frac{r}{\sqrt{N}}} + \int_{\frac{r}{\sqrt{N}}}^{\infty}.$$

Then

$$(10) \quad \int_{\frac{r}{\sqrt{N}}}^{\infty} y^{s-1} f(iy) dy = N^{-s/2} r^s \sum_{n=1}^{\infty} a_n \int_1^{\infty} y^{s-1} e^{-\frac{2\pi n r y}{\sqrt{N}}} dy.$$

On the other hand, the equation (8) gives us

$$(11) \quad \int_0^{\frac{r}{\sqrt{N}}} y^{s-1} f(iy) dy = N^{-s} \int_{\frac{1}{\sqrt{N}r}}^{\infty} y^{-s-1} f\left(\frac{i}{Ny}\right) dy \\ = \mu i^k N^{-s/2} r^{s-k} \sum_{n=1}^{\infty} a_n \int_1^{\infty} y^{k-s-1} e^{-\frac{2\pi n y}{\sqrt{N}r}} dy.$$

This shows the analytic continuation of $I(s)$ to the whole complex plane. The last integrals in (10) and (11) can be written as

$$\left(\frac{2\pi nr}{\sqrt{N}}\right)^{-s} \Gamma\left(s, \frac{2\pi nr}{\sqrt{N}}\right) \quad \text{and} \quad \left(\frac{\sqrt{N}r}{2\pi n}\right)^{k-s} \Gamma\left(k-s, \frac{2\pi n}{\sqrt{N}r}\right),$$

respectively. Hence we obtain the following

Lemma 1. *Let M be an arbitrary positive integer, then we have*

$$\begin{aligned} L(s, f) &= \frac{1}{\Gamma(s)} \sum_{n \leq M} \frac{a_n}{n^s} \Gamma\left(s, \frac{2\pi nr}{\sqrt{N}}\right) \\ &\quad + \frac{\mu i^k N^{k/2-s} (2\pi)^{2s-k}}{\Gamma(s)} \sum_{n \leq M} \frac{a_n}{n^{k-s}} \Gamma\left(k-s, \frac{2\pi n}{\sqrt{N}r}\right) \\ &\quad + (2\pi)^s \Gamma(s)^{-1} R, \end{aligned}$$

where

$$\begin{aligned} (12) \quad R &= N^{-s/2} r^s \sum_{n > M} a_n \int_1^\infty y^{s-1} e^{-\frac{2\pi n r y}{\sqrt{N}}} dy \\ &\quad + \mu i^k N^{-s/2} r^{s-k} \sum_{n > M} a_n \int_1^\infty y^{k-1-s} e^{-\frac{2\pi n y}{\sqrt{N}r}} dy. \end{aligned}$$

Now let us consider the case $k = 2$. We assume that $f(z)$ is a primitive form. The error term R in (12) can be written as

$$\begin{aligned} R &= N^{-s/2} r^s \sum_{n > M} a_n \int_1^\infty y^{s-1} e^{-\frac{2\pi n r y}{\sqrt{N}}} dy \\ &\quad - \mu N^{-s/2} r^{s-2} \sum_{n > M} a_n \int_1^\infty y^{1-s} e^{-\frac{2\pi n y}{\sqrt{N}r}} dy. \end{aligned}$$

As is stated in Section 1, we put

$$r = e^{i(\pi/2 - \delta(t))},$$

where $\delta(t)$ is a function of t satisfying $0 < \delta(t) \leq \pi/2$. Then

$$\begin{aligned} |R| \leq N^{-\sigma/2} e^{-(\pi/2 - \delta(t))t} &\left\{ \sum_{n > M} |a_n| \int_1^\infty y^{\sigma-1} e^{-\frac{2\pi n \sin \delta(t)}{\sqrt{N}} y} dy \right. \\ &\quad \left. + \sum_{n > M} |a_n| \int_1^\infty y^{1-\sigma} e^{-\frac{2\pi n \sin \delta(t)}{\sqrt{N}} y} dy \right\}. \end{aligned}$$

We may assume that $1 \leq \sigma < 3/2$, and we write $\lambda = 2\pi \sin \delta(t)$ for simplicity. The integrals in the right hand side of the above inequality are evaluated as

$$\int_1^\infty y^{\sigma-1} e^{-\frac{\lambda n y}{\sqrt{N}}} dy \leq \frac{\sqrt{N}}{\lambda n} e^{-\frac{\lambda n}{\sqrt{N}}} + \frac{N(\sigma-1)}{(\lambda n)^2} e^{-\frac{\lambda n}{\sqrt{N}}},$$

and

$$\int_1^\infty y^{1-\sigma} e^{-\frac{\lambda n y}{\sqrt{N}}} dy \leq \frac{\sqrt{N}}{\lambda n} e^{-\frac{\lambda n}{\sqrt{N}}}.$$

We also have $|a_n| \leq \sqrt{n}d(n)$. Hence we get

$$(13) \quad |R| \leq 2N^{(1-\sigma)/2}e^{-(\pi/2-\delta(t))t}\lambda^{-1} \sum_{n>M} \frac{d(n)}{n^{1/2}}e^{-\frac{\lambda n}{\sqrt{N}}} + (\sigma - 1)N^{1-\sigma/2}e^{-(\pi/2-\delta(t))t}\lambda^{-2} \sum_{n>M} \frac{d(n)}{n^{3/2}}e^{-\frac{\lambda n}{\sqrt{N}}}.$$

To evaluate the summations in the right hand side, we put $D(x) = \sum_{n \leq x} d(n)$. By the elementary fact

$$x(\log x - 1) \leq D(x) \leq x(\log x + 1)$$

and partial summation, we get

$$(14) \quad \sum_{n>M} \frac{d(n)}{n^{1/2}}e^{-\frac{\lambda n}{\sqrt{N}}} = -D(M)M^{-1/2}e^{-\frac{\lambda M}{\sqrt{N}}} - \int_M^\infty D(u)\frac{d}{du} \left(u^{-1/2}e^{-\frac{\lambda u}{\sqrt{N}}}\right) du \\ \leq -\sqrt{M}(\log M - 1)e^{-\frac{\lambda M}{\sqrt{N}}} + \int_M^\infty (\log u + 1) \left(\frac{\lambda}{\sqrt{N}}\sqrt{u} + \frac{1}{2\sqrt{u}}\right) e^{-\frac{\lambda u}{\sqrt{N}}} du \\ \leq \left(\frac{\log M + 2}{\lambda}\sqrt{\frac{N}{M}} + 2\sqrt{M}\right) e^{-\frac{\lambda M}{\sqrt{N}}}.$$

Similarly, we have that

$$(15) \quad \sum_{n>M} \frac{d(n)}{n^{3/2}}e^{-\frac{\lambda n}{\sqrt{N}}} \leq \left(\frac{2}{\sqrt{M}} + \frac{\log M + 2}{\lambda M}\sqrt{\frac{N}{M}}\right) e^{-\frac{\lambda M}{\sqrt{N}}}.$$

From (13), (14) and (15), we get

$$(16) \quad |R| \leq e^{-\frac{\pi}{2}t}e^{(t\delta(t)-\frac{\lambda M}{\sqrt{N}})}N^{(1-\sigma)/2} \left\{ \frac{4\sqrt{M}}{\lambda} + \frac{2(\log M + \sigma + 1)}{\lambda^2}\sqrt{\frac{N}{M}} + \frac{(\sigma - 1)(\log M + 2)}{\lambda^3\sqrt{M}}\frac{N}{M} \right\}.$$

Now take $M \geq t\sqrt{N}/4$ and use the inequality $\lambda > 4\delta(t)$, then we get Theorem 1.

3. PROOF OF THEOREM 2

To prove Theorem 2, we need the following lemma of Koksma.

Lemma 2 (Koksma’s inequality). *Let f be a real valued function on $[0, 1]$. Suppose that f has bounded variation. Let g be a real valued continuous strictly increasing function on $[0, 1]$ with $g(0) = 0$ and $g(1) = 1$. Then we have*

$$\left| \frac{1}{K} \sum_{n=1}^K f(x_n) - \int_0^1 f(t)dg(t) \right| \leq D_K^{(g)}(x_n)V(f),$$

for any sequence of real numbers $(x_n)_{n=1,2,\dots}$ in $[0, 1]$. Here $V(f)$ is the total variation of f in $[0, 1]$ and $D_K^{(g)}(x_n)$ is the discrepancy defined by (7).

Proof. See Kuipers and Niederreiter [11, p. 142] for the case $g(t) = t$. It is an easy exercise to generalize it to our case.

Now we prove Theorem 2. Put

$$A(s) = \prod_{p \notin \Delta} \frac{1}{1 - a_p p^{-s} + p^{1-2s}}$$

for $\text{Re } s > 3/2$. We note that

$$\log A(s) = \sum_p a_p p^{-s} + O\left(\sum_p p^{1-2\sigma}\right).$$

Since the error term is holomorphic in $\text{Re } s > 1/2$, we have only to consider the sum $\sum_p a_p p^{-s} = 2 \sum_p \cos(\theta_p) p^{1/2-s}$. (Here we can neglect the bad primes.) If this sum is holomorphic in $\text{Re } s > 1$, then $L(s, E)$ has no zeros in $\text{Re } s > 1$, which is the generalized Riemann Hypothesis for $L(s, E)$. By partial summation, we see that if

$$(17) \quad \sum_{p < x} \cos(\theta_p) = O(x^{1/2+\varepsilon}) \quad \text{for any } \varepsilon > 0,$$

then $\log A(s)$ is holomorphic in $\text{Re } s > 1$. Now, let $f(t) = \cos(\pi t)$ and $g(t) = ST(t)$ in Lemma 2. Then we have

$$(18) \quad \left| \frac{1}{K} \sum_{n=1}^K \cos(\theta_{p_n}) \right| \leq 2D_K^{(ST)}(x_n).$$

Hence, Conjecture 1 implies that $\sum_{n=1}^K \cos(\theta_{p_n}) = O(K^{1/2+\varepsilon})$. Combining this and (18), we see that (17) holds, and we get the desired result.

4. CONTINUED FRACTION OF THE INCOMPLETE GAMMA FUNCTION

The problem is that the calculation of incomplete gamma functions is very difficult and needs much time. Here it is appropriate to explain how to evaluate it with satisfactory accuracy. Let $\Gamma(s, z)$ be the incomplete gamma function of the second kind defined by (4), and let

$$(19) \quad \gamma(s, z) = \int_0^z e^{-t} t^{s-1} dt = \Gamma(s) - \Gamma(s, z)$$

be the incomplete gamma function of the first kind.

When z has a small absolute value, we can use the Taylor expansion:

$$\gamma(s, z) = \sum_{n=0}^{\infty} \frac{(-1)^n z^{s+n}}{n!(s+n)},$$

or the formula due to Legendre:

$$(20) \quad \gamma(s, z) = e^{-z} \sum_{n=0}^{\infty} \frac{\Gamma(s) z^{s+n}}{\Gamma(s+n+1)}.$$

When $|z|$ is large enough, we use the formula

$$(21) \quad \Gamma(s, z) = z^{s-1} e^{-z} \left(1 + \sum_{n=1}^{\infty} \frac{1}{z^n} (s-1)(s-2) \cdots (s-n) \right).$$

Note that the series of the right hand side is divergent and this equality should be considered as the asymptotic expansion at $z = \infty$. To calculate approximate values of $\gamma(s, z)$ and $\Gamma(s, z)$, we employ their classical continued fraction expansions:

$$(22) \quad \gamma(s, z) = z^s e^{-z} \cfrac{1}{s - \cfrac{s \cdot z}{s + 1 + \cfrac{1 \cdot z}{s + 2 - \cfrac{(s + 1)z}{s + 3 + \cfrac{2 \cdot z}{s + 4 - \cfrac{(s + 2)z}{s + 5 + \cfrac{3 \cdot z}{s + 6 - \dots}}}}}}}$$

and

$$(23) \quad \Gamma(s, z) = z^s e^{-z} \cfrac{1}{z + \cfrac{1 - s}{1 + \cfrac{1}{z + \cfrac{2 - s}{1 + \cfrac{2}{z + \cfrac{3 - s}{1 + \cfrac{3}{z + \dots}}}}}}}$$

These formulas are special cases of Gauss’s continued fraction method using confluent hypergeometric functions (see Jones and Thron [5], pp. 205-209 and pp. 344-348 or Wall [22]). As a formal power series of z and s , (22) (resp. (23)) is equivalent to (20) (resp. (21)). However, the continued fraction in (22) is convergent for any z and s with $\text{Re } s > 0$, and the one in (23) for z with $|\arg z| < \pi$ and $s \neq 1, 2, 3, \dots$.

To estimate the truncation error of these continued fraction expansions, we quote the result of [5]: Let θ, ξ_{-1} be real numbers with $0 < |\theta| < \pi$ and let $\{a_n\}_{n=0,1,2,\dots}$ be a sequence of arbitrary non-zero complex numbers. We define $\xi_n = \arg a_n - \xi_{n-1} - \theta$ recursively. Let $\{b_n\}_{n=0,1,2,\dots}$ be another sequence of complex numbers satisfying the conditions

$$\begin{aligned} 0 \leq \arg b_n - \xi_n \leq \theta & \quad \text{if } 0 < \theta < \pi, \\ \theta \leq \arg b_n - \xi_n \leq 0 & \quad \text{if } -\pi < \theta < 0. \end{aligned}$$

Consider the continued fraction

$$(24) \quad \cfrac{a_0}{b_0 + \cfrac{a_1}{b_1 + \cfrac{a_2}{b_2 + \dots}}}$$

Then Jones and Thron (see Th. 8.8 in [5] and [6]) proved the following

Theorem 3 (Jones and Thron). *If the continued fraction (24) converges to a value x , then*

$$\begin{cases} \left| x - \frac{P_n}{Q_n} \right| \leq \left| \frac{P_n}{Q_n} - \frac{P_{n-1}}{Q_{n-1}} \right|, & \text{if } 0 < |\theta| \leq \frac{\pi}{2}, \\ \left| x - \frac{P_n}{Q_n} \right| \leq \frac{1}{|\sin \theta|} \left| \frac{P_n}{Q_n} - \frac{P_{n-1}}{Q_{n-1}} \right|, & \text{if } \frac{\pi}{2} < |\theta| < \pi, \end{cases}$$

where P_n/Q_n ($n = 0, 1, 2, \dots$) is the n -th convergent of the continued fraction (24).

First we apply Theorem 3 to (22). Let P_n/Q_n ($n = 0, 1, 2, \dots$) be the n -th convergent of the continued fraction expansion of $\gamma(s, z)z^{-s}e^z$. Put

$$b_n = \begin{cases} nz, & n \text{ even}, \\ -(s + (n - 1)/2)z, & n \text{ odd}. \end{cases}$$

Then it is easily seen that

$$Q_n = (s + n + 1)Q_{n-1} + b_nQ_{n-2},$$

and

$$P_nQ_{n-1} - P_{n-1}Q_n = -b_n(P_{n-1}Q_{n-2} - P_{n-2}Q_{n-1}).$$

Thus we have

$$\begin{aligned} Q_{2n-1} &= \sum_{k=0}^n (-1)^k \binom{n}{k} \frac{\Gamma(2n - k + s)}{\Gamma(s)} z^k \\ Q_{2n} &= \sum_{k=0}^n (-1)^k \binom{n}{k} \frac{\Gamma(2n + 1 - k + s)}{\Gamma(s)} z^k, \end{aligned}$$

and

$$(25) \quad \frac{P_{2n}}{Q_{2n}} - \frac{P_{2n-1}}{Q_{2n-1}} = \frac{(-1)^n n! \Gamma(s + n)}{\Gamma(s) Q_{2n} Q_{2n-1}} = \frac{(-1)^n n! \Gamma(s)}{\Gamma(s + n) Q_{2n}^* Q_{2n-1}^*},$$

where, in the right hand side of (25), we put

$$\begin{aligned} Q_{2n-1}^* &= \sum_{k=0}^n (-1)^k \binom{n}{k} \frac{\Gamma(s + n + k)}{\Gamma(s + n)} z^{-k}, \\ Q_{2n}^* &= \sum_{k=0}^n (-1)^k \binom{n}{k} \frac{\Gamma(s + n + 1 + k)}{\Gamma(s + n)} z^{-k}, \end{aligned}$$

or in another way

$$(26) \quad \begin{aligned} Q_{2n-1}^* &= \sum_{k=0}^n \binom{n}{k} \left(1 + \frac{n+k-1}{s} \right) \left(1 + \frac{n+k-2}{s} \right) \cdots \left(1 + \frac{n}{s} \right) \left(-\frac{z}{s} \right)^{-k}, \\ Q_{2n}^* &= \sum_{k=0}^n \binom{n}{k} \left(1 + \frac{n+k}{s} \right) \left(1 + \frac{n+k-1}{s} \right) \cdots \left(1 + \frac{n}{s} \right) \left(-\frac{x}{s} \right)^{-k}. \end{aligned}$$

The error estimate of (23) proceeds similarly. Let U_n/V_n ($n = 0, 1, 2, \dots$) be the n -th convergent of $\Gamma(s, z)z^{-s}e^z$, then we can show by induction

$$V_{2n-1} = \sum_{k=0}^n \binom{n}{k} \frac{\Gamma(n+1-s)}{\Gamma(k+1-s)} x^k,$$

$$V_{2n} = \sum_{k=0}^n \binom{n}{k} \frac{\Gamma(n+1-s)}{\Gamma(k+2-s)} x^{k+1}.$$

Thus we have

$$(27) \quad \frac{U_{2n}}{V_{2n}} - \frac{U_{2n-1}}{V_{2n-1}} = \frac{n! \Gamma(n+1-s)}{\Gamma(1-s) V_{2n} V_{2n-1}} = \frac{n! \Gamma(1-s)}{\Gamma(n+2-s) V_{2n}^* V_{2n-1}^*},$$

where

$$V_{2n-1}^* = \sum_{k=0}^n \binom{n}{k} \frac{\Gamma(1-s)}{\Gamma(k+1-s)} z^k,$$

$$V_{2n}^* = \sum_{k=0}^n \binom{n}{k} \frac{\Gamma(1-s)}{\Gamma(k+2-s)} z^{k+1},$$

or similarly,

$$(28) \quad V_{2n-1}^* = \sum_{k=0}^n \binom{n}{k} \frac{(-z/s)^k}{(1 - \frac{k}{s})(1 - \frac{k-1}{s}) \dots (1 - \frac{1}{s})},$$

$$V_{2n}^* = \sum_{k=0}^n \binom{n}{k} \frac{(-z/s)^{k+1}}{(1 - \frac{k+1}{s})(1 - \frac{k}{s}) \dots (1 - \frac{1}{s})}.$$

Applying the Theorem of Jones and Thron, we can estimate the truncation error by (25) or (27). The expressions (26) and (28) suggest that there exists a kind of duality. Thus, to calculate the precise value of $\Gamma(s, z)$, it is better to use (23) when $|z| \geq |s|$ and (22) when $|z| < |s|$. Numerical experiments suggest that this choice is very suitable. Note that, if necessary, we must apply Theorem 3 to the sub-expression of (22) and (23) because the first finite terms may not satisfy the condition of Theorem 3.

5. EXAMPLES

In this section, we give examples of our calculations. In the graphs of zeta functions or L -functions below, the horizontal axis (resp. vertical axis) represents the real part (resp. imaginary part) of their values.

As a model, we first show two graphs of the Riemann zeta function on the critical line (Figures 1 and 2). The range of t is written under each graph. Figures 3, 4, 5, and 6 are the graphs of the Hurwitz zeta function $\zeta(1/2 + it, j/5)$, ($j = 1, \dots, 4$) for $50.00 \leq t \leq 60.00$. Figure 7 is the Dirichlet L -function $L(1/2 + it, \chi)$, where χ is the Dirichlet character mod 5 determined by $\chi(2) = \exp(2\pi i \frac{3}{4})$. It is interesting that the Hurwitz zeta function moves rather randomly but their sum, the Dirichlet L -function, moves as the Riemann zeta function. We calculated their values by the Euler-Maclaurin summation formula.

For L -functions associated to elliptic curves, we study four examples with different Mordell-Weil ranks. Let

$$\begin{aligned} E_{11} : y^2 + y &= x^3 - x^2 - 10x - 20, & N = 11, & r = 0, \\ E_{37} : y^2 + y &= x^3 - x, & N = 37, & r = 1, \\ E_{446} : y^2 + xy &= x^3 - x^2 - 4x + 4, & N = 446, & r = 2, \\ E_{5077} : y^2 + y &= x^3 - 7x + 6, & N = 5077, & r = 3, \end{aligned}$$

where N and r represent the conductor and the Mordell-Weil rank of E , respectively. (See Figures 8, 9, 10, 11, 13, 14, 16, 18, 17 and 19.) In the following subsections, we show the graphs of $L(s, E_N)$ and some other data. For these, we used the method of Sections 2 and 4.

Figures 12, 15 and 20 are the graphs of $L(1 + it, E_N)$ when t is close to 0. By Tables 1, 2, and 3, up to the numerical precision of the calculation, we can see that $L(s, E_{37})$, $L(s, E_{446})$ and $L(s, E_{5077})$ have zeros of order 1, 2 and 3 at $s = 1$, respectively. This observation is compatible with the Birch and Swinnerton-Dyer conjecture.

One can ask whether all non-trivial zeros lie on the critical line $\operatorname{Re}(s) = 1$ or not. The generalized Riemann hypothesis insists that this is the case. As is stated in Section 1, Yoshida and Fermigier showed that it holds true in the range of their calculation. In our cases, we have

Theorem 4. *The generalized Riemann Hypothesis is true for the above four elliptic curves in the range $\operatorname{Im}(s) \leq 400$. Moreover, all non-trivial zeros except the one at $s = 1$ are simple.*

Theorem 4 can be shown by the classical method of Backlund (cf. Edwards [3], Yoshida [24]). The zeros in this range are listed in Tables 4, 5 and 6.

Figures 21, 22 and 23 are the graphs of $L(\sigma + it, E_{5077})$ $17.7 \leq t \leq 20.5$ for $\sigma = 0.98, 1.00, 1.02$, respectively. It is interesting to see how $L(s, E)$ takes the value 0 on the critical line $\operatorname{Re}(s) = 1$.

Figures 24, 25, 26 and 27 are numerical experiments of Conjecture 1 in Section 1. In these figures, the horizontal axis and vertical axis represent K and $\sqrt{K}D_K^{(ST)}(x_n)$, respectively.

We used Kida's UBASIC86 on 80486-66Mhz first and Pentium-133Mhz later. We also used PARI for the calculations of a_n and Mathematica for drawing the graphs. According to Theorem 1, time evaluation for the calculation of $L(1 + it, E_N)$ is $O(t\sqrt{N})$ if we ignore the incomplete gamma function. But the bottleneck is the calculation of the incomplete gamma function. It takes an enormous amount of time at the present stage. For example, on 80486-66Mhz, it takes about 150 hours for $L(1 + it, E_{11})$ and 900 hours for $L(1 + it, E_{5077})$ with sufficiently many division points in the range $0 \leq t \leq 400$. So we did not aim to make a complete list here, leaving it as a future problem. But for a single t , even if it is large, we can calculate the value of $L(s, E)$ in the critical strip. For example,

$$\begin{aligned} L(1 + 1000i, E_{5077}) &= 0.97714 - 0.79882i, \\ L(1 + 3000i, E_{5077}) &= 1.87754 - 1.90091i. \end{aligned}$$

The correctness of our calculation is checked by comparison with Yoshida's data for $L(s, E_{11})$. Moreover, for the above four curves, we checked the invariance of the data with $\delta(t) = 1/(1+t)$ and $\delta(t) = 1/(1+\log^2 t)$. (It seems to be a convenient way to check the correctness.)

One can find our programs on <ftp://ftp.math.metro-u.ac.jp/tnt>.

5.1. **The Riemann zeta function:** $\zeta(1/2 + it)$.

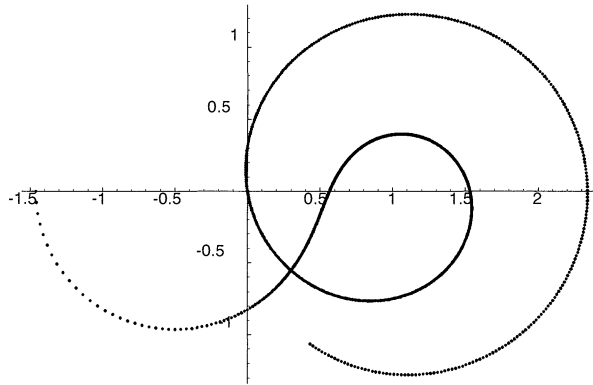

FIGURE 1. $0 \leq t \leq 20$

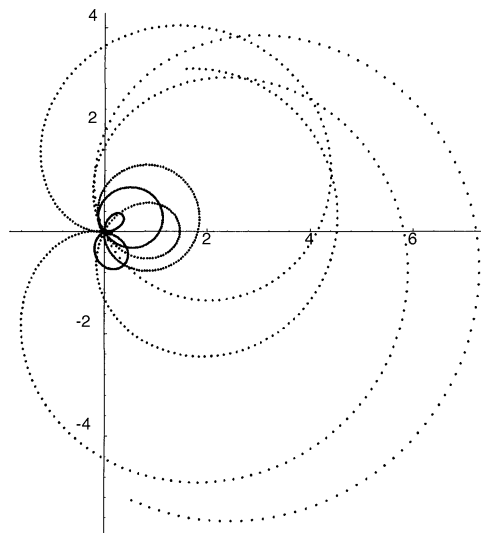

FIGURE 2. $3000 \leq t \leq 3010$

(The horizontal and vertical axes indicate the real and imaginary parts of the Riemann zeta function.)

The Hurwitz zeta function: $\zeta(1/2 + it, \alpha)$.

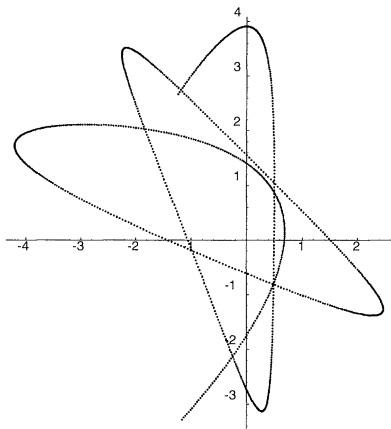

FIGURE 3. $\alpha = 1/5$ for $50 \leq t \leq 60$

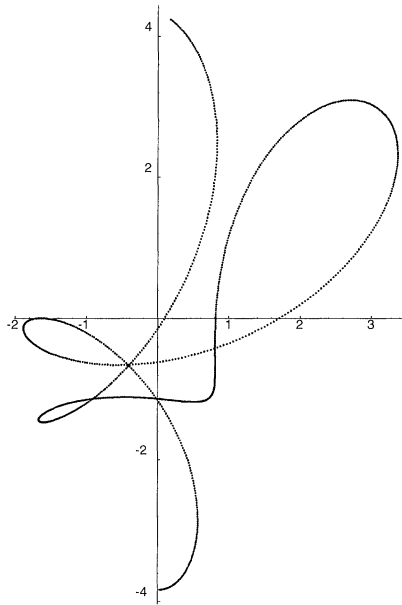

FIGURE 4. $\alpha = 2/5$ for $50 \leq t \leq 60$

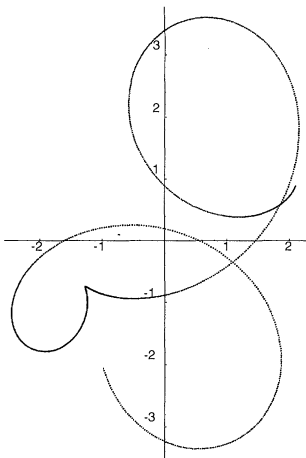

FIGURE 5. $\alpha = 3/5$ for $50 \leq t \leq 60$

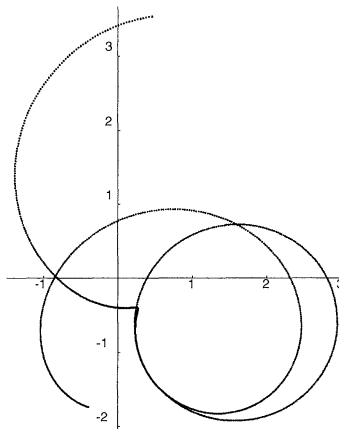
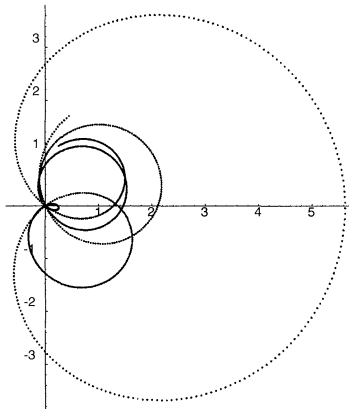

FIGURE 6. $\alpha = 4/5$ for $50 \leq t \leq 60$

(The horizontal and vertical axes indicate the real and imaginary parts of the Hurwitz zeta function.)

The Dirichlet L -function: $L(1/2 + it, \chi)$.



Here χ is the Dirichlet character mod 5 determined by $\chi(2) = \exp(2\pi i \frac{3}{4})$. Hence, we have

$$L(s, \chi) = 5^{-s} \sum_{j=1}^4 \chi(j) \zeta(s, j/5).$$

FIGURE 7. $50.00 \leq t \leq 60$

5.2. L -function of E_{11} : $L(1 + it, E_{11})$

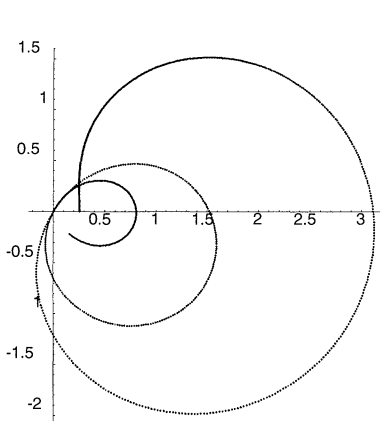

FIGURE 8. $0.00 \leq t \leq 9.89$

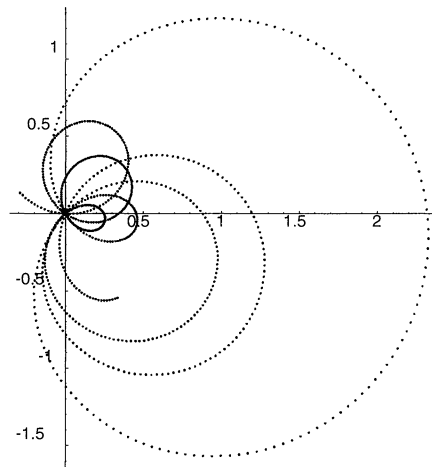

FIGURE 9. $397.00 \leq t \leq 401.00$

(The horizontal and vertical axes indicate the real and imaginary parts of the $L(1/2 + it, \chi)$ and $(1 + it, E_{11})$.)

5.3. L -function of E_{37} : $L(1 + it, E_{37})$.FIGURE 10. $0.00 \leq t \leq 9.39$ FIGURE 11. $396.03 \leq t \leq 400.00$ FIGURE 12. $-1.99 \leq t \leq 1.99$

TABLE 1

t	$L(1 + it, E_{37})$
0.000	0.0000000000000000
0.001	-0.000000186547781+0.000305999910626 i
0.002	-0.000000746190931+0.000612000642000 i
0.003	-0.000001678928871+0.000918003014876 i
0.004	-0.000002984760633+0.001224007850009 i
0.005	-0.000004663684865+0.001530015968161 i
0.006	-0.000006715699827+0.001836028190105 i
0.007	-0.000009140803393+0.002142045336623 i
0.008	-0.000011938993049+0.002448068228511 i
0.009	-0.000015110265897+0.002754097686581 i
0.010	-0.000018654618649+0.003060134531663 i
0.011	-0.000022572047631+0.003366179584607 i
0.012	-0.000026862548784+0.003672233666284 i
0.013	-0.000031526117659+0.003978297597591 i
0.014	-0.000036562749423+0.004284372199452 i
0.015	-0.000041972438852+0.004590458292819 i

(The horizontal and vertical axes indicate the real and imaginary parts of the $L(1 + it, E_{37})$.)

5.4. L -function of E_{446} : $L(1 + it, E_{446})$.

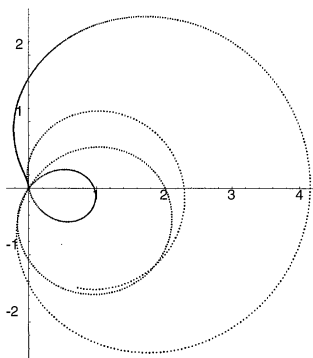
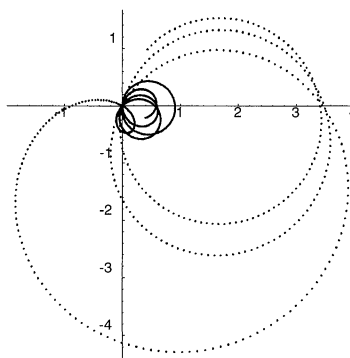
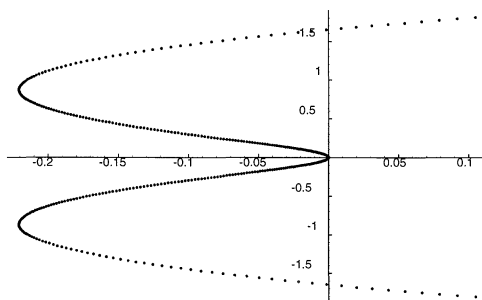
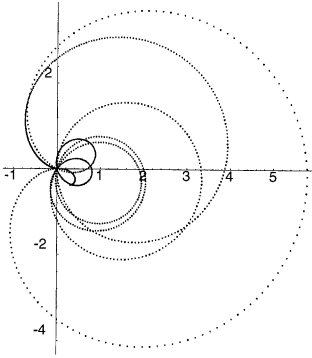

FIGURE 13. $0.00 \leq t \leq 9.39$

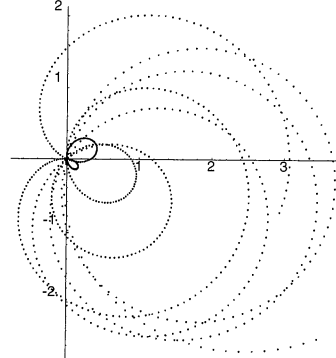

FIGURE 14. $396.03 \leq t \leq 400.00$

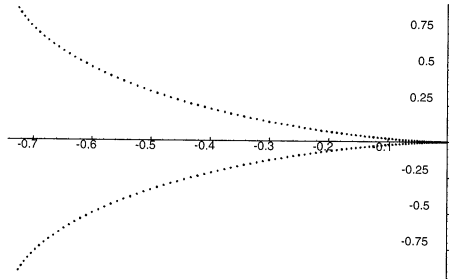
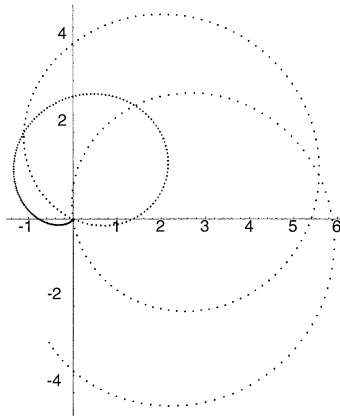
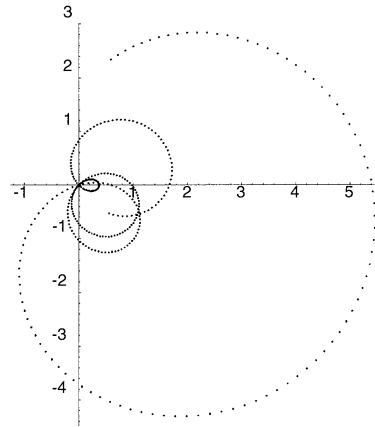
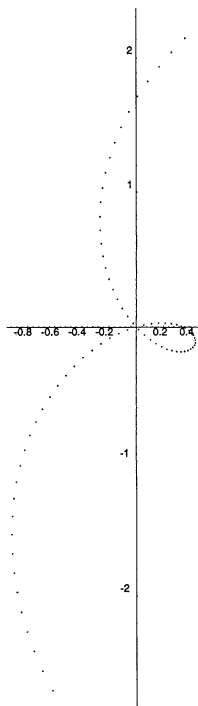

FIGURE 15. $-1.99 \leq t \leq 1.99$

TABLE 2

t	$L(1 + it, E_{446})$
0.000	0.0000000000000000
0.001	-0.000000940282805+0.000000000597143 i
0.002	-0.000003761133629+0.000000004777156 i
0.003	-0.000008462559692+0.000000016122982 i
0.004	-0.000015044573030+0.000000038217700 i
0.005	-0.000023507190494+0.000000074644603 i
0.006	-0.000033850433742+0.000000128987263 i
0.007	-0.000046074329248+0.000000204829601 i
0.008	-0.000060178908289+0.000000305755963 i
0.009	-0.000076164206951+0.000000435351183 i
0.010	-0.000094030266122+0.000000597200654 i
0.011	-0.000113777131493+0.000000794890405 i
0.012	-0.000135404853548+0.000001032007162 i
0.013	-0.000158913487567+0.000001312138424 i
0.014	-0.000184303093618+0.000001638872532 i
0.015	-0.000211573736555+0.000002015798735 i

(The horizontal and vertical axes indicate the real and imaginary parts of the $L(1 + it, E_{446})$.)

5.5. *L*-function of E_{5077} : $L(1 + it, E_{5077})$.FIGURE 16. $0 \leq t \leq 4.19$ FIGURE 17. $5.00 \leq t \leq 8.39$ FIGURE 18. $4.20 \leq t \leq 4.99$

(The horizontal and vertical axes indicate the real and imaginary parts of the $L(1 + it, E_{5077})$.)

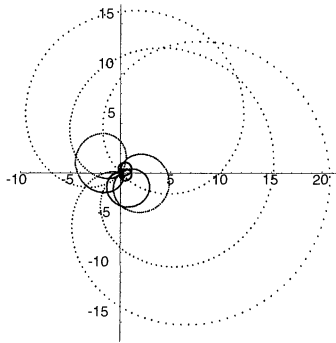

FIGURE 19. $390.00 \leq t \leq 396.00$

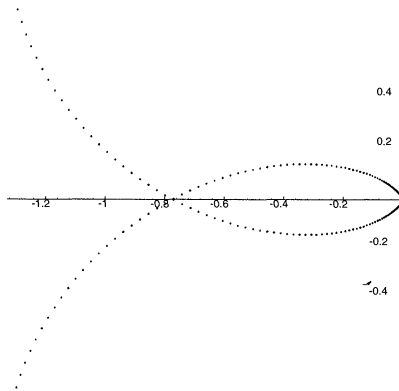

FIGURE 20. $-0.99 \leq t \leq 0.99$

TABLE 3

t	$L(1 + it, E_{5077})$
0.000	0.0000000000000000
0.001	-0.000000000003206-0.000000001731847 i
0.002	-0.000000000051294-0.000000013854710 i
0.003	-0.000000000259678-0.000000046759267 i
0.004	-0.000000000820708-0.000000110835526 i
0.005	-0.000000002003678-0.000000216472487 i
0.006	-0.000000004154815-0.000000374057805 i
0.007	-0.000000007697282-0.000000593977454 i
0.008	-0.000000013131172-0.000000886615393 i
0.009	-0.000000021033507-0.000001262353229 i
0.010	-0.000000032058228-0.000001731569878 i
0.011	-0.000000046936197-0.000002304641235 i
0.012	-0.000000066475186-0.000002991939830 i
0.013	-0.000000091559873-0.000003803834498 i
0.014	-0.000000123151835-0.000004750690038 i
0.015	-0.000000162289539-0.000005842866880 i

(The horizontal and vertical axes indicate the real and imaginary parts of the $L(1 + it, E_{5077})$.)

Graphs of $L(\sigma + it, E_{5077})$ for various σ , and $17.7 \leq t \leq 20.045$.

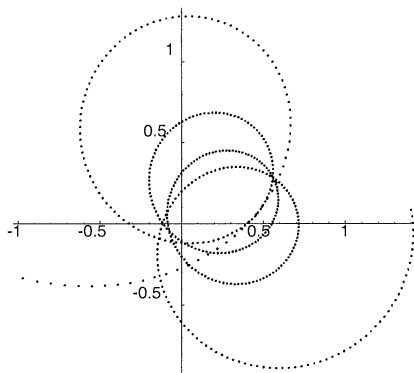

FIGURE 21. $\sigma = 0.98$

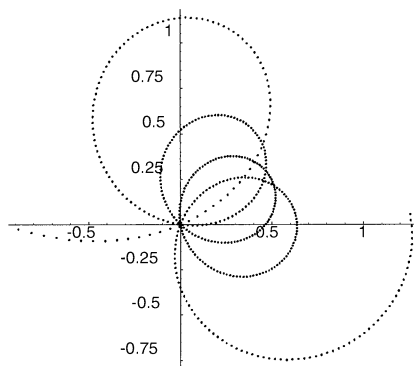

FIGURE 22. $\sigma = 1.00$

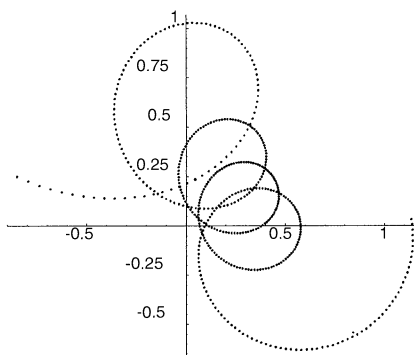

FIGURE 23. $\sigma = 1.02$

(The horizontal and vertical axes indicate the real and imaginary parts of the $L(\sigma + it, E_{5077})$.)

5.6. Numerical experiment of Conjecture 1.

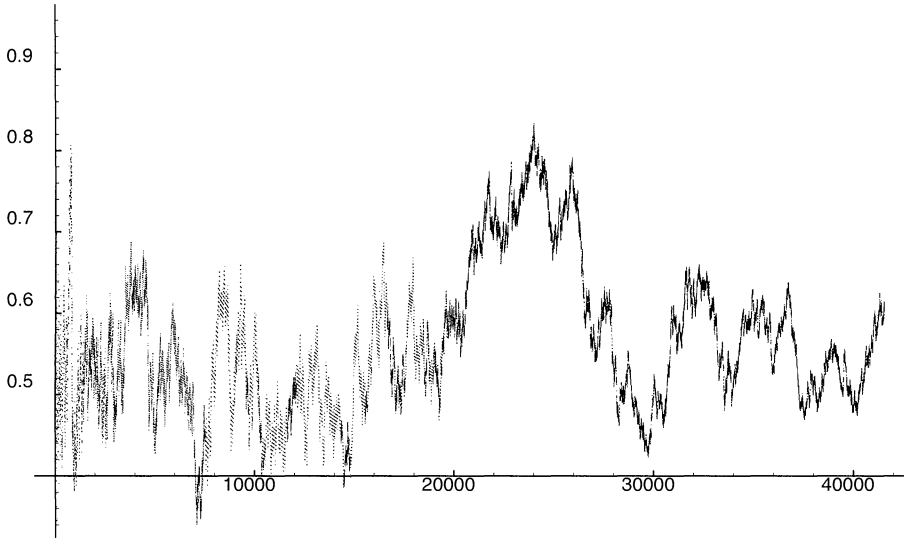

FIGURE 24. Discrepancy for E_{11}

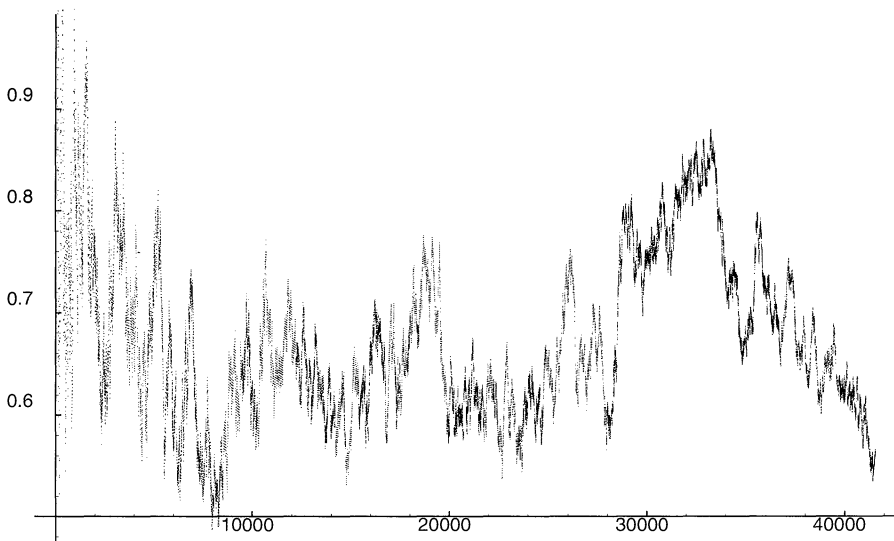
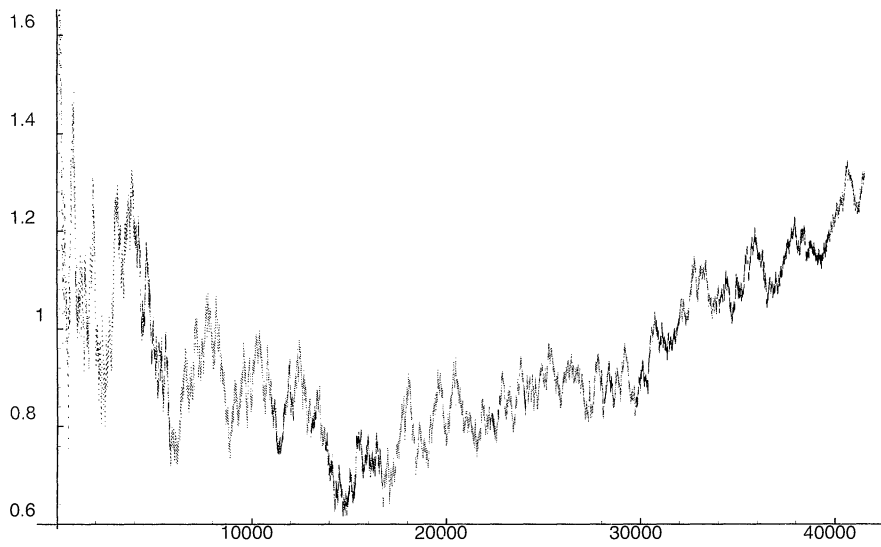
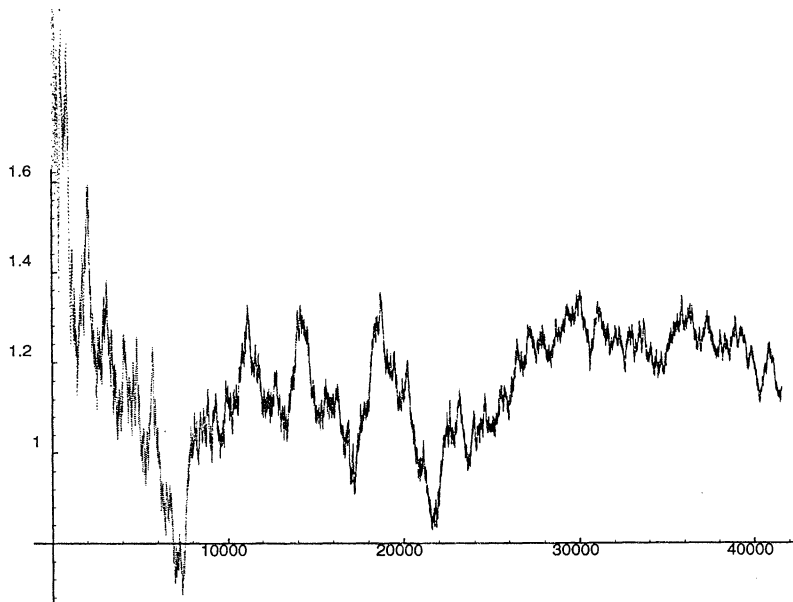

FIGURE 25. Discrepancy for E_{37}

(The horizontal and vertical axes indicate K and $\sqrt{K}D_K^{(ST)}(x_n)$, respectively.)

FIGURE 26. Discrepancy for E_{446} FIGURE 27. Discrepancy for E_{5077}

(The horizontal and vertical axes indicate K and $\sqrt{K}D_K^{(ST)}(x_n)$, respectively.)

TABLE 5. Zeros of $L(s, E_{37})$, $\text{Im}(s) \leq 400$

0.000	5.003	6.870	8.014	9.933	10.775	11.757	12.958	15.604	16.192	17.142	18.064
18.787	19.815	21.323	22.620	23.328	24.169	25.657	26.814	27.339	28.190	29.030	29.282
30.896	32.042	33.441	34.363	34.636	35.462	36.164	37.084	38.468	39.002	39.604	40.649
41.652	42.575	44.034	44.236	45.393	45.565	46.653	46.957	47.574	49.342	50.219	51.003
51.719	52.411	53.001	54.039	54.977	55.291	56.257	56.957	57.715	58.399	59.096	60.668
61.445	62.295	62.640	63.039	63.884	64.344	65.379	66.069	67.215	68.084	68.400	69.527
70.195	70.817	71.458	72.700	73.278	73.751	74.154	74.865	75.524	76.441	77.756	78.530
79.152	79.788	80.613	81.143	81.338	82.167	83.093	83.860	84.574	85.464	86.193	86.405
87.315	88.478	89.271	89.926	90.347	91.074	91.548	92.031	92.847	93.343	94.325	95.292
96.414	96.816	97.553	97.887	98.417	99.431	99.767	100.922	101.328	102.155	102.361	103.247
104.001	104.763	105.428	106.597	107.276	107.716	108.302	108.887	109.600	109.764	110.248	111.228
112.600	113.141	113.336	114.440	115.059	115.577	116.225	117.031	117.610	118.304	118.869	119.594
120.065	120.692	120.963	122.027	122.793	123.911	124.659	125.243	125.546	126.049	126.558	127.302
127.863	128.624	129.122	130.023	130.774	131.434	131.976	132.572	133.443	133.706	134.912	135.569
136.038	136.615	136.990	137.368	138.141	138.778	139.303	140.614	141.088	142.143	142.236	143.248
143.677	144.192	144.596	145.085	146.040	146.993	147.038	148.074	148.519	149.116	149.630	150.269
151.676	151.976	152.555	153.273	153.824	154.363	154.749	155.311	155.770	156.405	157.161	158.099
159.089	159.477	159.994	160.681	161.112	161.793	162.273	163.139	163.709	164.556	164.686	165.223
165.841	166.576	167.484	167.572	168.489	169.646	170.273	170.781	171.249	171.611	172.207	172.752
173.007	173.852	174.598	175.479	176.071	176.403	177.350	177.831	178.397	179.151	179.542	180.471
181.002	181.432	182.128	182.732	183.240	183.522	183.937	184.654	185.838	186.363	187.466	187.685
188.320	188.875	189.247	189.749	190.615	190.930	191.439	192.110	193.059	193.492	194.152	194.651
195.226	195.832	196.503	197.216	198.152	198.689	199.121	199.582	199.785	200.710	200.905	201.572
202.108	203.030	203.789	204.439	204.993	205.837	206.347	206.717	207.145	207.560	208.285	209.111
209.863	210.121	210.634	211.245	211.788	212.374	212.985	213.588	214.687	215.172	215.778	216.286
216.930	217.385	217.767	218.192	218.732	219.296	219.859	220.649	221.769	222.047	222.796	223.118
223.446	224.654	224.775	225.570	226.087	226.776	227.292	227.788	228.337	228.644	229.310	230.060
230.396	230.945	232.085	232.933	233.396	233.866	234.215	234.941	235.236	235.679	236.203	236.795
237.783	238.209	238.596	239.445	239.951	240.518	241.230	241.689	242.159	243.070	243.534	244.215
244.808	245.322	245.676	246.074	246.516	247.061	247.497	248.742	249.134	249.970	250.460	251.307
251.563	252.056	252.605	253.079	253.693	254.176	254.696	255.383	256.050	256.706	256.939	257.723
258.044	258.680	259.347	260.102	261.078	261.595	261.831	262.329	262.684	263.300	264.037	264.206
264.829	265.211	266.026	267.107	267.568	267.828	268.962	269.124	269.737	270.019	270.629	271.312
272.064	272.567	273.118	273.412	274.105	274.426	275.000	275.574	276.211	277.070	277.546	278.322
278.988	279.494	279.970	280.464	280.827	281.255	281.510	282.433	282.735	283.694	284.286	284.947
285.457	285.815	286.322	287.215	287.585	288.276	288.827	289.264	290.080	290.524	290.931	291.307
291.934	292.342	292.826	293.546	293.852	294.933	295.932	296.241	296.669	297.274	297.515	298.289
298.553	299.036	299.760	300.211	301.093	301.385	301.667	302.689	303.193	303.750	304.138	304.487
305.436	306.123	306.915	307.058	307.777	308.404	308.587	309.004	309.527	309.883	310.458	311.311
311.926	312.715	313.148	313.751	314.493	314.811	315.250	316.062	316.333	316.576	317.367	318.090
318.542	319.328	319.600	320.074	320.263	321.233	321.639	322.234	323.096	323.824	324.410	324.775
325.353	325.639	326.172	326.694	327.211	327.655	327.939	328.565	329.599	330.032	330.826	331.190
331.676	332.453	332.695	333.218	333.655	334.681	335.205	335.550	336.041	336.441	336.958	337.507
338.046	338.370	338.990	339.839	340.228	341.101	341.749	342.527	342.751	343.094	343.651	344.059
344.256	345.182	345.592	346.062	346.861	347.454	347.958	348.473	348.820	349.481	350.076	350.771
351.253	351.818	352.270	353.191	353.480	353.761	354.461	354.843	355.246	355.678	356.013	356.798
357.650	358.585	358.883	359.311	360.013	360.361	360.959	361.539	361.676	362.417	362.756	363.656
363.966	364.569	365.018	365.505	366.214	366.831	367.069	367.428	368.306	369.180	369.813	370.189
370.735	371.137	371.547	372.077	372.341	372.672	373.567	373.924	374.689	375.120	375.896	376.501
377.159	377.534	377.954	378.607	378.926	379.507	380.025	380.557	381.328	381.866	382.267	382.519
383.045	383.417	384.167	384.626	385.331	385.798	386.948	387.176	387.809	388.159	388.577	389.313
389.611	390.000	390.539	390.799	391.339	392.262	392.802	393.534	393.905	394.349	394.915	395.328
395.975	396.528	397.099	397.901	398.204	398.688	399.126	399.684	400.123			

TABLE 6. Zeros of $L(s, E_{446})$, $\text{Im}(s) \leq 400$

0.000	3.017	4.440	5.480	6.649	7.361	8.060	9.759	10.227	11.122	11.943	12.387
13.046	15.042	15.644	16.306	16.548	17.516	18.552	18.851	19.701	20.271	21.663	22.239
23.002	23.421	24.000	24.720	26.117	26.489	27.238	27.793	28.535	28.872	29.524	30.167
31.285	31.977	32.376	33.782	34.081	34.548	35.207	35.576	36.140	36.906	38.247	38.776
39.038	39.528	39.852	41.164	41.769	42.180	42.820	43.986	44.247	44.865	45.598	46.041
46.609	46.980	47.504	48.280	49.272	50.095	50.573	51.286	51.564	52.062	52.433	53.520
54.306	54.540	55.299	55.708	56.325	57.211	57.686	58.071	58.601	58.893	60.128	60.999
61.663	61.838	62.382	63.011	63.506	63.653	64.581	65.183	65.873	66.383	67.125	67.722
68.238	68.682	69.396	70.124	70.515	70.897	71.288	72.419	73.320	73.609	73.856	74.267
74.736	75.360	75.878	76.665	77.697	78.243	78.484	78.891	79.765	80.376	80.885	81.112
81.525	82.057	83.000	83.498	84.108	84.646	85.267	85.897	86.233	86.560	87.159	87.894
88.583	89.525	89.729	90.363	90.593	91.084	91.631	92.301	92.917	93.255	93.752	94.229
94.992	96.097	96.529	96.891	97.287	97.757	98.087	98.549	99.383	100.178	100.405	101.101
101.891	101.926	102.705	102.874	103.480	104.234	104.849	105.253	105.912	106.550	107.074	107.716
108.071	108.589	109.210	109.556	109.963	110.240	110.508	112.142	112.497	112.948	113.138	113.952
114.170	115.042	115.542	115.778	116.471	116.992	117.542	118.078	118.512	119.389	119.674	120.309
120.435	120.751	121.532	122.076	122.648	123.415	124.087	124.807	125.081	125.404	125.710	126.342
126.535	127.407	128.002	128.385	129.085	129.345	129.973	130.454	131.161	131.943	132.186	132.445
132.891	133.481	133.984	134.905	135.504	136.014	136.279	136.665	137.073	137.462	138.161	138.744
138.847	139.801	140.127	141.134	141.612	141.970	142.190	142.881	143.630	143.975	144.198	144.848
144.972	145.659	146.543	147.226	147.354	148.059	148.570	148.704	149.310	149.445	150.304	151.299
151.727	152.164	152.349	152.846	153.774	154.025	154.615	154.876	155.296	155.703	156.480	156.596
157.310	158.014	158.867	159.184	159.537	160.258	160.378	160.850	161.364	161.999	162.148	163.073
163.864	164.094	164.549	164.888	165.142	165.814	166.567	166.788	167.508	167.885	168.128	168.887
169.641	170.319	170.812	171.066	171.451	171.768	172.183	172.757	172.995	173.934	174.232	174.940
175.515	175.908	176.242	176.949	177.164	178.097	178.335	178.636	179.111	179.927	180.331	180.870
181.220	181.699	182.474	182.886	183.290	183.692	183.792	184.289	184.613	185.826	186.438	186.859
187.313	187.797	188.231	188.428	188.953	189.456	190.235	190.521	191.010	191.118	191.844	192.408
193.239	193.552	194.038	194.270	194.679	195.434	195.889	196.273	196.499	197.417	198.075	198.704
198.856	199.355	199.605	200.287	200.455	200.852	201.570	201.944	202.694	202.978	203.736	203.898
204.596	205.276	205.795	206.317	206.478	206.752	207.372	207.490	208.148	208.983	209.716	210.007
210.361	210.652	211.193	211.508	212.143	212.719	212.839	213.678	214.111	214.902	215.196	215.682
216.106	216.627	217.043	217.608	217.883	218.415	219.022	219.816	220.139	220.549	221.596	221.596
222.163	222.497	222.623	223.157	223.388	223.809	224.742	225.309	225.492	226.032	226.522	227.010
227.543	227.852	228.487	228.673	229.418	229.784	230.025	230.520	230.790	231.783	232.560	233.019
233.096	233.772	234.092	234.633	234.986	235.387	235.709	235.968	236.848	237.387	238.027	238.454
238.709	238.971	239.579	240.300	240.608	241.182	241.754	241.924	242.379	242.882	243.263	244.352
244.619	244.979	245.539	245.718	246.117	246.464	246.842	247.363	247.996	248.697	249.092	249.687
250.109	250.525	251.083	251.573	251.908	252.226	252.674	253.168	253.660	254.278	254.563	254.877
255.585	256.225	256.646	257.177	257.305	258.252	258.658	259.063	259.662	260.489	261.039	261.039
261.400	261.938	262.114	262.374	262.593	263.529	264.110	264.363	264.766	265.089	265.288	266.213
266.869	267.226	267.805	268.251	268.760	269.100	269.423	269.909	270.119	270.710	271.200	272.151
272.250	272.746	273.207	273.869	274.120	274.376	274.612	275.259	275.774	276.332	277.048	277.404
277.640	278.286	278.847	279.188	280.007	280.267	280.603	280.764	281.348	281.558	281.969	282.626
283.320	284.048	284.337	284.562	285.055	285.589	285.973	286.394	286.943	287.377	287.867	288.282
288.820	289.172	289.766	290.283	290.798	290.910	291.593	291.734	292.332	292.901	293.089	293.552
293.919	294.407	295.623	296.005	296.385	296.654	296.904	297.250	297.765	298.347	298.562	299.258
299.486	300.404	300.639	300.930	301.373	301.937	302.263	303.202	303.378	303.806	304.103	304.411
304.899	305.608	306.331	306.553	307.106	307.490	308.126	308.414	308.709	309.246	309.298	309.787
310.410	310.796	311.566	311.809	312.559	312.989	313.302	313.758	314.266	314.579	315.269	315.685
316.012	316.279	316.649	317.117	317.597	318.617	318.823	319.414	319.536	320.020	320.350	320.628
321.085	321.586	322.482	322.847	323.145	323.878	324.154	324.841	325.011	325.384	325.905	326.423
326.655	327.058	327.640	328.008	328.315	328.778	329.536	329.961	330.513	330.959	331.296	331.882
332.348	332.561	332.798	333.169	333.697	334.721	335.154	335.492	335.821	336.149	336.347	336.954
337.569	337.950	338.389	338.676	339.068	339.597	340.246	340.590	341.106	341.937	342.269	342.699
343.057	343.200	343.525	344.030	344.585	344.942	345.483	345.810	346.491	346.973	347.521	347.834
348.233	348.619	348.793	349.416	350.115	350.613	350.849	351.228	351.898	352.181	352.755	353.028
353.795	354.220	354.483	354.845	355.307	355.611	355.711	356.279	356.815	357.774	358.184	358.714
359.068	359.290	359.734	360.189	360.777	360.906	361.587	361.979	362.408	362.504	363.219	364.006
364.125	364.634	365.087	365.390	365.852	366.552	366.820	367.148	367.459	367.942	368.455	369.234
369.774	370.147	370.530	371.021	371.242	371.599	372.100	372.181	372.723	373.270	374.079	374.334
374.681	375.028	375.422	376.094	376.921	377.229	377.460	377.788	378.306	378.576	379.068	379.389
380.004	380.432	380.972	381.715	381.946	382.322	382.525	382.951	383.435	383.735	384.378	384.654
385.078	385.696	386.514	386.893	387.202	387.503	387.916	388.292	388.993	389.310	389.802	390.029
390.521	390.676	391.073	391.595	392.438	392.870	393.393	393.858	394.090	394.327	394.872	395.187
395.675	396.257	396.707	397.181	397.670	398.083	398.408	399.082	399.269	399.566	400.335	

TABLE 7. Zeros of $L(s, E_{5077})$, $\text{Im}(s) \leq 400$

0.000	2.052	3.262	4.471	4.754	6.012	6.623	7.343	7.707	8.477	9.382	10.203
10.496	11.033	11.687	12.287	12.973	13.152	14.942	15.515	15.895	16.440	16.643	17.412
18.073	18.560	19.031	19.497	19.975	20.660	21.759	22.216	22.735	23.224	23.721	24.030
24.827	25.822	26.322	26.557	27.205	27.741	28.215	28.455	29.030	29.581	29.778	30.873
31.675	31.827	32.338	33.462	33.975	34.394	34.547	35.200	35.648	35.817	36.427	36.913
38.058	38.411	38.720	39.262	39.513	39.965	40.721	41.575	41.816	42.524	42.970	43.755
44.262	44.430	44.988	45.323	46.028	46.336	46.743	46.999	47.413	48.029	48.632	49.488
50.192	50.521	51.132	51.475	51.811	52.379	52.575	53.526	53.922	54.317	55.018	55.261
55.633	55.837	56.859	57.229	57.777	58.096	58.459	58.689	59.695	60.127	61.152	61.534
61.905	62.192	62.406	63.165	63.346	63.757	64.193	64.662	65.336	65.719	66.272	66.712
67.463	67.915	68.274	68.546	69.163	70.023	70.303	70.709	70.817	71.315	72.024	72.925
73.211	73.440	73.865	74.169	74.580	74.871	75.306	76.001	76.623	77.210	77.917	78.264
78.690	78.916	79.613	80.315	80.428	80.958	81.212	81.487	82.004	82.312	83.197	83.604
83.863	84.439	85.000	85.603	85.895	86.312	86.683	86.858	87.702	88.242	88.910	89.422
89.845	90.003	90.431	90.865	91.209	91.622	91.973	92.666	92.964	93.422	93.821	94.148
94.877	95.529	96.267	96.530	97.149	97.315	97.453	98.168	98.340	98.664	99.591	99.956
100.227	100.712	101.209	101.820	102.029	102.397	102.809	103.016	104.066	104.317	104.576	105.075
105.909	106.246	106.775	107.046	107.746	107.949	108.480	108.791	109.194	109.586	109.955	110.005
110.573	110.800	112.206	112.571	112.769	113.289	113.424	113.846	114.532	115.173	115.528	115.714
116.101	116.859	117.188	117.459	117.943	118.313	118.935	119.341	119.877	120.060	120.262	120.665
121.314	121.663	122.256	122.542	123.319	123.959	124.304	124.921	125.218	125.431	125.866	126.075
126.354	126.873	127.424	128.158	128.229	128.689	128.945	129.619	130.022	130.454	130.997	131.656
131.910	132.311	132.659	132.919	133.418	134.046	134.378	135.155	135.578	135.944	136.262	136.437
136.829	137.173	137.574	138.015	138.603	138.816	139.227	139.946	140.441	140.905	141.518	141.909
142.128	142.407	143.306	143.556	143.755	144.400	144.527	144.799	145.156	145.729	146.338	146.871
147.167	147.617	148.002	148.598	148.719	149.207	149.387	149.737	150.582	151.388	151.791	151.908
152.326	152.650	153.221	153.616	154.018	154.446	154.834	155.050	155.433	155.626	156.252	156.597
157.083	157.577	158.386	158.597	159.178	159.669	159.987	160.194	160.600	161.046	161.592	161.892
162.114	162.658	163.234	163.941	164.161	164.405	164.701	164.882	165.364	165.993	166.435	166.793
167.368	167.745	167.985	168.470	168.741	169.848	170.197	170.655	170.884	171.167	171.392	171.859
172.308	172.433	172.971	173.168	173.785	174.332	174.782	175.244	175.632	175.962	176.465	177.004
177.184	177.656	178.226	178.588	178.986	179.219	179.859	180.300	180.791	180.871	181.448	181.754
182.232	182.811	183.189	183.320	183.664	183.940	184.187	184.626	185.572	186.153	186.572	186.762
187.514	187.856	188.046	188.455	188.745	188.983	189.792	190.190	190.318	190.805	191.032	191.426
191.855	192.384	192.806	193.462	193.821	194.175	194.394	194.662	195.328	195.818	196.172	196.282
197.012	197.475	198.146	198.425	198.928	199.145	199.285	199.812	200.118	200.474	200.702	201.141
201.725	202.128	202.388	203.120	203.529	203.852	204.192	204.803	205.161	205.949	206.227	206.414
206.826	206.966	207.274	207.661	208.111	208.886	209.253	209.539	210.235	210.355	210.612	210.946
211.167	212.089	212.322	212.534	213.149	213.441	213.915	214.610	215.133	215.478	215.513	216.092
216.615	216.870	217.362	217.590	217.945	218.270	218.591	218.922	219.522	219.779	220.064	220.546
221.591	221.965	222.283	222.423	222.713	223.229	223.475	223.910	224.439	224.997	225.465	225.786
225.973	226.403	226.884	227.110	227.754	228.052	228.322	228.615	229.076	229.555	230.011	230.307
230.497	230.896	231.502	232.491	232.749	233.016	233.325	233.756	234.327	234.439	234.962	235.085
235.447	235.805	236.065	236.668	237.234	237.463	238.124	238.458	238.792	239.005	239.283	240.119
240.379	240.818	241.335	241.579	242.039	242.254	242.760	243.172	243.570	244.180	244.630	244.964
245.240	245.588	245.813	246.271	246.351	246.715	247.106	247.710	248.354	248.659	249.266	249.564
249.891	250.440	250.830	251.326	251.586	252.007	252.306	252.540	252.896	253.589	253.753	254.192
254.588	254.742	255.273	255.833	256.273	256.594	257.017	257.395	257.720	258.061	258.296	258.877
259.111	259.704	260.432	260.841	261.353	261.577	261.876	262.164	262.356	262.683	262.993	263.869
264.196	264.321	264.691	264.969	265.128	265.774	266.521	266.905	267.224	267.754	268.134	268.553
268.941	269.225	269.540	269.892	270.442	270.628	270.847	271.497	272.284	272.451	272.594	272.978
273.562	273.850	274.098	274.475	274.813	275.086	275.613	276.095	276.804	277.024	277.348	277.881
278.107	278.678	279.175	279.736	279.791	280.348	280.527	280.871	281.055	281.502	281.773	282.029
282.475	283.278	283.760	284.011	284.302	284.855	285.243	285.548	285.887	286.141	286.673	287.232
287.573	288.035	288.339	288.676	288.898	289.623	290.017	290.263	290.679	290.961	291.201	291.586
292.098	292.555	292.694	292.988	293.497	293.849	294.378	294.632	295.692	296.016	296.412	296.600
296.915	297.071	297.553	297.752	298.503	298.718	298.970	299.198	299.992	300.401	300.612	300.846
301.336	301.635	301.961	302.625	303.284	303.471	303.696	304.071	304.243	304.672	305.255	305.916
306.157	306.733	307.014	307.296	307.703	308.258	308.369	308.823	308.947	309.367	309.644	309.898
310.377	310.902	311.403	311.783	312.428	312.615	313.090	313.425	313.756	314.178	314.690	315.116
315.399	315.795	316.065	316.461	316.651	317.033	317.291	317.994	318.463	318.996	319.224	319.571
319.816	319.997	320.451	320.796	321.144	321.775	322.156	322.688	322.918	323.548	324.028	324.328
324.653	324.933	325.288	325.806	326.033	326.303	326.798	327.008	327.329	327.861	328.116	328.456
328.750	329.297	330.083	330.397	330.579	331.146	331.257	331.940	332.422	332.640	332.782	332.916
333.357	334.158	334.745	335.068	335.361	335.634	335.973	336.108	336.548	337.020	337.289	337.713
338.159	338.441	338.962	339.289	339.416	340.136	340.439	341.006	341.403	342.013	342.409	342.694
342.890	343.285	343.566	343.734	344.013	344.569	345.079	345.287	345.710	346.105	346.404	347.001
347.496	347.810	348.217	348.386	348.620	349.102	349.527	350.088	350.586	350.806	351.294	351.424
352.093	352.384	352.680	352.964	353.505	354.149	354.338	354.574	354.651	355.160	355.485	355.893
356.012	356.325	357.067	357.678	358.415	358.496	358.848	359.130	359.402	359.997	360.357	360.668
360.984	361.427	361.779	362.120	362.403	362.584	363.219	363.633	364.101	364.331	364.658	364.997
365.380	365.886	366.234	366.771	366.955	367.423	367.470	367.752	368.694	368.962	369.577	369.934
370.381	370.581	370.877	371.351	371.485	371.795	372.083	372.342	372.914	373.123	373.737	374.151
374.619	374.783	375.090	375.483	376.069	376.667	377.161	377.312	377.560	378.033	378.266	378.744
378.973	379.460	379.626	380.186	380.536	381.002	381.563	381.801	382.154	382.347	382.730	382.838
383.391	383.810	384.118	384.519	384.938	385.287	385.853	386.429	386.729	387.163	387.567	387.837
388.007	388.538	388.674	389.421	389.730	389.948	390.196	390.574	390.797	390.886	391.495	392.077
392.781	392.896	393.393	393.899	394.049	394.480	394.658	395.074	395.232	396.055	396.243	396.980
397.112	397.387	397.861	398.324	398.687	398.998	399.135	399.527	399.926	400.512		

6. APPENDIX: TYPE SEQUENCE AND ROSSER'S LAW

In the history of calculation of zeros of the Riemann zeta function, two laws, which are not exact laws, have appeared that play an important role. They are Gram's and Rosser's laws and formulated as follows. First we recall that the argument of $\zeta(1/2 + it)$ is given by $-\vartheta(t)$, where

$$\vartheta(t) = \text{Im}(\log \Gamma(\frac{1}{4} + i\frac{t}{2})) - \frac{1}{2}t \log \pi.$$

Let g_k be the positive real number which satisfies

$$\vartheta(g_k) = k\pi, \quad k = -1, 0, 1, 2, \dots$$

These numbers g_k are called (k -th) Gram points. Gram's law is stated as follows.

Gram's law: There exists exactly one zero in the interval $(1/2 + ig_k, 1/2 + ig_{k+1})$.

This statement is slightly stronger than usual in the sense that it asserts "exactly one" instead of "at least one". To simplify matters, we assume that $\zeta(1/2 + ig_k) \neq 0$ for any Gram point g_k . If $\zeta(1/2 + ig_k) > 0$ (resp. < 0), then g_k is called a good (resp. bad) Gram point. If all the Gram points are good then Gram's law is true. But this is not the case. This law fails for the first time at $g_{126} = 282.454\dots$. In fact, $\zeta(1/2 + it) \neq 0$ for $g_{125} < t < g_{126}$, and g_{126} is a bad Gram point.

Define a Gram block of length k by the set of consecutive Gram points $B_n = \{g_n, g_{n+1}, \dots, g_{n+k}\}$, where g_n and g_{n+k} are good and g_{n+j} ($j = 1, 2, \dots, k - 1$) are bad. Then Rosser's law is stated as follows.

Rosser's law: Let $B_n = \{g_n, g_{n+1}, \dots, g_{n+k}\}$ be a Gram block of length k , then $\zeta(s)$ has at least k zeros in the interval $(1/2 + ig_n, 1/2 + ig_{n+k})$.

This law fails for the first time at $B_{13999525}$.

Now we classify all the non-trivial zeros of $\zeta(s)$ into five classes.

Definition 1. Let $u = 1/2 + it_0$ ($t > 0$) be a zero of $\zeta(s)$. Define the zero u to be of type j ($j = 1, 2, 3, 4$) when $-i\zeta'(u)$ belongs to the j -th quadrant R_j . If u is not in the above cases, we say that u is of type 0.

It seems that type 0 does not occur for the Riemann zeta function. But for the case of the L -function associated to an elliptic curve E of Mordell-Weil rank greater than one, it actually happens on the critical line $\text{Re}(s) = 1$, because $L'(1, E) = 0$ (under the Birch and Swinnerton-Dyer conjecture for this curve). Let ε be a small positive number. When $u = 1/2 + it_0$ is of type j , then the orbit of $\zeta(1/2 + it)$ for $t \in (t_0 - \varepsilon, t_0 + \varepsilon)$ starts from R_j and passes through the origin.

We define the type sequence by the sequence of types of zeros and Gram points (represented by G or B according to a good or a bad Gram point) arranged in increasing order. For example, in the middle of Table 8, one can find the sequence "G B24 G4". The meaning of this sequence is as follows. As t is increasing, the **Good** Gram point(= g_{125}), the **Bad** Gram point(= g_{126}), zero of type **2**, zero of type **4**, the **Good** Gram point(= g_{127}) and zero of type **4** occur in this order. Hence we see that $B_{125} = \{g_{125}, g_{126}, g_{127}\}$ is a Gram block of length 2 and contains 2 zeros. We mentioned above that Rosser's law fails at $B_{13999525}$. The type sequence about this point is "BGBG424G". The Table 8 suggests that:

1. Gram's law seems to be true in a certain average sense,
2. A bad Gram point occurs when the order of a zero and a Gram point is reversed.

Let us consider the first point. Let $S(r) = \pi^{-1} \arg \zeta(1/2+ir)$ where the branch of $i \arg \zeta(s) = \text{Im}(\log(\zeta(s)))$ is taken along the lines joining $2, 2+ir$ and $2+ir, 1/2+ir$. It is known that the number of zeros in the rectangle $\{z \in \mathbf{C} : 0 < \text{Re}(z) < 1, 0 < \text{Im}(z) \leq r\}$ is equal to

$$\frac{r}{2\pi} \log\left(\frac{r}{2\pi}\right) - \frac{r}{2\pi} + S(r) + O(1/r).$$

We can easily see that

$$\frac{g_k}{2\pi} \log\left(\frac{g_k}{2\pi}\right) - \frac{g_k}{2\pi} = k + O(1/g_k).$$

Hence, it would be plausible that

Conjecture 2. $S(g_k) = 0$ for all the good Gram points g_k except the ones with zero density.

Conjecture 2 has another heuristic explanation. Let g_k be a "generic" good Gram point. Then we may assume that the value of $\zeta(1/2 + ig_k)$ is greater than 1 (see Theorem 10.6 of [20]). Let $\sigma > 1/2$ and δ be a small positive number. We compare the graphs of $\zeta(1/2 + ir)$ and $\zeta(\sigma + ir)$ in the Gaussian plain for $r \in [g_k - \delta, g_k + \delta]$. When σ is increasing, the orbit of the graph of $\zeta(\sigma + ir)$ moves to the outer normal direction by the Cauchy-Riemann relation. Note that the argument of $\zeta(1/2 + ir)$ always decreases. Thus when σ gets larger, we may expect that the graph of $\zeta(\sigma + ir)$ will naturally approach a single value

$$\lim_{\sigma \rightarrow \infty} \zeta(\sigma + ir) = 1.$$

In this process, the graph would not approach the origin, as $\zeta(1/2 + ig_k) > 1$. This suggests Conjecture 2. Of course, in the above argument, we assume that there are no non-trivial zeros in $\{z \in \mathbf{C} : 1/2 \leq \text{Re}(z), |\text{Im}(z) - g_k| \leq \delta\}$.

If Conjecture 2 is true, we could formulate Rosser's law in a strengthened way:

Each Gram block of length k has exactly k zeros.

In fact, if a Gram block of length k has more than k zeros, then the front or rear Gram block may have length more than the number of zeros in it.

Now we will treat the second point. Consider relatively simple cases when a zero and its adjacent Gram point are reversed. When the graph of $\zeta(1/2 + ir)$ moves a little along the real axis, then the changes

$$(29) \quad 3G \rightarrow B2, \quad G4 \rightarrow 1B$$

occur in the type sequence. On the other hand, when the graph moves along the imaginary axis, the changes

$$(30) \quad 1B \rightarrow 2B, \quad B2 \rightarrow B1$$

occur. For example, $GB24G4$ or $G31BG4$ in Table 8 are obtained from the normal sequence $G3G4G4$ by the replacements in (29).

Let T be the type sequence provided with Rosser's law (we treat here the "abstract" type sequence), and let T' be the type sequence generated from T by the successive replacements of (29) and (30). Then it is easily seen that T' also satisfies Rosser's law. Thus Rosser's law, somewhat complicated at first glance, can be grasped in the context of *Gram's law in the "average" sense*.

Our argument is naturally extended to L -functions associated to elliptic curves. Tables 9 and 10 are the type sequence of the L -functions associated to E_{11} and E_{5077} .

TABLE 8. Type sequence of the Riemann zeta function Read $G4G3G4G3\cdots$

G4	G3	G4	G3	G4	G3	G3	G4	G3	G4	G4	G3	G4	G3	
G4	G4	G4	G3	G4	G4	G3	G4	G3	G4	G3	G3	G4	G4	G3
G3	G4	G4	G3	G4	G4	G4	G3	G3	G4	G4	G3	G4	G4	G3
G4	G3	G3	G4	G4	G3	G4	G3	G4	G4	G3	G3	G4	G4	G4
G3	G3	G3	G4	G3	G3	G4	G4	G4	G3	G3	G4	G4	G4	G3
G4	G3	G4	G4	G3	G3	G3	G4	G3	G3	G3	G3	G4	G4	G3
G3	G4	G3	G4	G3	G3	G3	G4	G4	G3	G3	G3	G4	G4	G4
G3	G3	G4	G4	G4	G3	G4	G3	G4	G4	G3	G3	G4	G4	G4
G4	G3	G3	G4	G4	G4	G	B24	G4	G3	G4	G4	G3	G3	G31
B	G4	G3	G3	G4	G3	G4	G4	G3	G3	G4	G4	G4	G3	G4
G3	G4	G4	G4	G3	G3	G4	G4	G3	G4	G3	G3	G3	G4	G4
G3	G3	G4	G3	G4	G4	G4	G3	G3	G4	G4	G4	G3	G3	G3
G3	G4	G4	G3	G3	G3	G4	G4	G4	G4	G3	G3	G4	G4	G4
G	B23	G4	G3	G4	G4	G3	G3	G3	G4	G4	G3	G3	G3	G3
G4	G31	B	G3	G3	G4	G4	G4	G4	G3	G4	G3	G3	G4	G4

TABLE 9. Type sequence for $L(s, E_{11})$ Read $G3G3G4G4\cdots$

G3	G3	G4	G4	G4	G3	G3	G4	G4	G4	G3	G4	G3	G3	G3
G31	B	G4	G3	G3	G3	G3	G4	G3	G4	G4	G4	G4	G3	G3
G	B24	G4	G4	G4	G4	G3	G3	G3	G4	G3	G4	G4	G4	G4
G4	G3	G3	G3	G3	G4	G4	G41	B	G4	G3	G4	G3	G3	G3
G3	G4	G3	G31	B	G4	G3	G4	G	B23	G3	G4	G4	G4	G4
G4	G4	G3	G3	G3	G3	G3	G3	G4	G41	B	G4	G4	G4	G3
G3	G3	G3	G3	G31	B	G3	G4	G3	G4	G4	G3	G	B23	G3
G3	G4	G4	G4	G4	G4	G3	G4	G3	G3	G3	G4	G3	G3	G4
G41	B	G4	G3	G3	G3	G	B23	G3	G4	G4	G3	G4	G4	G3
G4	G4	G3	G3	G3	G3	G3	G3	G4	G31	B	G4	G3	G4	G
B23	G3	G4	G4	G3	G4	G4	G4	G4	G4	G4	G3	G3	G3	G3
G3	G3	G3	G4	G41	B	G4	G3	G4	G3	G3	G3	G3	G3	G4
G3	G4	G4	G41	B	G3	G4	G3	G3	G	B23	G3	G4	G4	G4
G4	G4	G4	G3	G3	G4	G4	G3	G3	G3	G3	G3	G4	G4	G41
B	G3	G4	G3	G3	G3	G3	G3	G4	G4	G4	G4	G4	G4	G4

TABLE 10. Type sequence of $L(s, E_{5077})$ Read $0BG4G4\cdots$

0	B	G4	G4	G3	G4	G3	G3	G3	G4	G4	G3	G4	G4	G4
G4	G4	G41	B	G	B2	B23	G3	G4	G4	G3	G4	G4	G41	B
G4	G3	G3	G3	G3	G41	B	G4	G	B2	B23	G3	G3	G3	G4
G4	G42	B	G4	G3	G4	G4	G	B2	B2	B24	G3	G31	B1	B1
B	G	B23	G4	G41	B1	B	G4	G3	G4	G3	G4	G	B2	B23
G3	G4	G3	G4	G41	B1	B1	B	G3	G3	G	B23	G	B23	G4
G31	B	G3	G3	G3	G3	G4	G41	B	G3	G4	G3	G4	G41	B
G3	G4	G	B1	B2	B23	G4	G3	G4	G41	B1	B	G4	G4	G4
G4	G3	G3	G3	G4	G4	G	B23	G31	B	G4	G3	G	B2	B23
G4	G4	G41	B1	B	G4	G4	G3	G	B23	G3	G4	G3	G	B23
G3	G41	B	G41	B	G3	G3	G4	G4	G3	G3	G3	G4	G41	B
G3	G3	G	B2	B2	B23	G3	G4	G4	G41	B	G4	G4	G4	G41
B	G4	G3	G	B2	B2	B23	G4	G3	G41	B	G3	G3	G4	G4
G3	G3	G4	G4	G41	B	G3	G4	G4	G4	G	B23	G	B23	G
B23	G3	G3	G3	G4	G42	B1	B2	B	G	B2	B23	G3	G4	G4

In contrast with the Riemann zeta function, the type sequence is pretty complicated for $L(s, E_{5077})$ but does not violate Rosser’s law in this range. There exist many reverses of $3G \rightarrow B2$ and $G4 \rightarrow 1B$. Furthermore, one can find some reverses coming from (30). For example, in Table 10, $G42BG$ is obtained as

$$G4G4G \rightarrow G41BG \rightarrow G42BG.$$

This observation shows why counterexamples of Rosser’s law cannot be found in the short range. However, if we perform the calculation to a wider range, an arbitrary

complicated change of type sequences would happen, and might violate Rosser's law. We can actually observe such a change at the breaking point of Rosser's law.

ACKNOWLEDGMENTS

The authors wish to thank Professor L. Murata for his careful reading of the manuscript, and Professor A. Ivić for pointing out the present record of the validity of the Riemann Hypothesis. They also thank the referee for many valuable comments.

REFERENCES

- [1] J. E. Cremona, *Algorithms for Modular Elliptic Curves*, Cambridge University Press, 1992. MR **93m**:11053
- [2] F. Diamond, On deformation rings and Hecke rings, preprint.
- [3] H. M. Edwards, *Riemann's Zeta Function*, Academic Press, 1974. MR **57**:5922
- [4] S. Fermigier, Zéros des Fonction L de Courbes Elliptiques, *Experimental Math.*, **1** (1992), no.2, 167-173. MR **94b**:11126
- [5] W.B. Jones and W.J. Thron, *Continued fractions, Analytic Theory and Applications*, Encyclopedia of Math. and its Appl., **11** Addison-Wesley, 1980. MR **82c**:30001
- [6] W.B. Jones and W.J. Thron, *A Posteriori Bounds for the Truncation Error of Continued fractions*, *SIAM J. Numer. Anal.* **8** (1971), 693-705. MR **45**:4602
- [7] S. Hitotumatu, J. Yamauchi and T. Uno, *Sūchikeisanhou III (Numerical Computing Methods III)*, Baihukan, 1971 (Japanese).
- [8] T. Kano (ed.) *Riemann yosou (Riemann Hypothesis)*, Nihonhyouronsha, 1991 (Japanese).
- [9] A. A. Karatsuba, *Basic Analytic Number Theory*, Springer-Verlag, 1991 (English translation). MR **94a**:11001
- [10] A. W. Knap, *Elliptic curves*, Princeton University Press, 1992. MR **93j**:11032
- [11] L. Kuipers and H. Niederreiter, *Uniform Distribution of Sequences*, John Wiley & Sons, New York, 1974. MR **54**:7415
- [12] A. F. Lavrik, Approximate functional equation for Dirichlet Functions, *Izv. Akad. Nauk SSSR* **32** (1968), 134–185. MR **36**:6361
- [13] J.van de Lune, H.J.J.te Riele and D.T.Winter, On the zeros of the Riemann zeta function on the critical strip IV, *Math. Comp.*, **46** (1986), 667–681. MR **87e**:11102
- [14] Ju. I. Manin, Cyclotomic fields and modular curves, *Russian Math. Surveys* **26** (1971), 7-71. MR **53**:5480
- [15] ———, Parabolic points and zeta-functions of modular curves, *Izv. Akad. Nauk SSSR Ser. Mat.* **36** (1972), 19–66. MR **47**:3396
- [16] A.M. Odlyzko, The 10^{20} -th Zeros of the Riemann Zeta Function and 70 Million of its Neighbors, preprint
- [17] A. P. Ogg, A remark on the Sato-Tate conjecture, *Invent. Math.* **9** (1970), 198-200. MR **41**:3481
- [18] F. Shahidi, Symmetric power L -functions for $GL(2)$, *Elliptic Curves and Related Topics*, ed. by H. Kisilevsky and R. Murty, CRM Proc. and Lecture Notes vol **4** (1994), 159-182. MR **95c**:11066
- [19] R. Taylor and A. Wiles, Ring-theoretic properties of certain Hecke algebras, *Ann. of Math.* **114** (1995), 553-572. MR **96d**:11072
- [20] E.C.Titchmarsh, *The Theory of the Riemann Zeta Function* (revised by D.R.Heath-Brown) 2nd edition, Oxford University Press, 1986. MR **88c**:11049
- [21] R. T. Turganaliyev, *An approximate functional equation and moments of the Dirichlet series generated by the Ramanujan function*, *Izv. Akad. Nauk Repub. Kazakhstan Ser. Fiz.-Mat.* (1992), 49-55 (Russian). MR **94m**:11061
- [22] H.S. Wall, *Analytic theory of continued fractions*, Chelsea Publ., 1948. MR **10**:32d
- [23] A. Wiles, *Modular elliptic curves and Fermat's Last Theorem*, *Ann. of Math.* **114** (1995), 443-551. MR **96d**:11071
- [24] H. Yoshida, *On calculations of zeros L -functions related with Ramanujan's discriminant function on the critical line*, *J. Ramanujan Math. Soc.* **3**(1) (1988), 87-95. MR **90b**:11044

- [25] ———, *On calculations of zeros of various L -functions*, Symposium on automorphic forms at Kinosaki (1993), 47-72.

DEPARTMENT OF MATHEMATICS, FACULTY OF SCIENCE, NIIGATA UNIVERSITY, IKARASHI
2-8050, NIIGATA 950-2181, JAPAN

E-mail address: `akiyama@math.sc.niigata-u.ac.jp`

GRADUATE SCHOOL OF MATHEMATICS, NAGOYA UNIVERSITY, CHIKUSA-KU, NAGOYA 464-8602,
JAPAN

E-mail address: `tanigawa@math.nagoya-u.ac.jp`