

3.03, 3.33, 3.53, 3.59 (Me₃Si), 46.19, 46.83 (CH₂), 69.14, 70.11 (CHOSiMe₃), 157.30, 159.97 (=C(OSiMe₃)Si), 125.98, 126.82, 126.76, 129.69, 129.80, 130.11, 130.29, 137.74, 137.99, 141.39, 141.54 (phenyl and remaining vinylic carbons, some signals obscured by C₆D₆); ²⁹Si NMR δ 14.92, 15.00, 15.72, 16.45 (OSiMe₃), -11.24, -11.33 (double intensity), -11.48, -11.90, -12.66 (SiMe₃), -59.06, -59.50, -68.77, -72.33 (SiSi₃); IR (neat) 1603 cm⁻¹ (C=C); MS, *m/e* (relative intensity) 367 ([PhCH₂CH(OSiMe₃)Si(SiMe₃)₂]⁺, 76), 191 ([Me₃SiOC=CHPh]⁺, 20).

3d: white solid; mp 216-218 °C; ¹H NMR δ 0.06, 0.16, 0.58 (s, SiMe₃), CH₂ (AB spin system) (H_A, 3.65, H_B, 3.71 ppm, *J*_{AB} = (-)19.05 Hz), 7.00-7.53 (m, phenyl); ¹³C NMR δ 2.59, 3.56, 3.95 (SiMe₃), 41.19 (CH₂), 93.09 (ring C), 126.10, 128.68, 130.01, 140.37 (phenyl); ²⁹Si NMR δ 6.69 (OSiMe₃), -10.67, -12.02 (SiMe₃), -48.29 (ring Si); IR (KBr disk) 2952 (m), 2895 (m), 3026 (w), 3061 (w), 1250 (m), 1261 (m), 837 (s), 1045 (s) cm⁻¹; MS, *m/e* (relative intensity) 384 ([((Me₃SiO)(PhCH₂)C)₂]⁺, 3), 366 ([((Me₃Si)₂Si=C(OSiMe₃)(CH₂Ph)]⁺, 10), 348 ([((Me₃Si)₂Si)₂]⁺, 69).

Cophotolysis of Isobutyrylsilane 1c with Methanol. A solution of isobutyrylsilane **1c** (45 mg, 0.14 mmol) in methanol (0.5 mL) containing one drop of pyridine was photolyzed for 2.5 h. The solvent was then removed under vacuum and the major product, the methanol adduct **6**, purified by chromatography (80/20 hexanes/CH₂Cl₂; silica gel).

(α -(Trimethylsiloxy)isobutyl)bis(trimethylsilyl)methoxysilane (**6**): colorless oil; yield 25%; ¹H NMR δ 0.21, 0.31, 0.34 (s, SiMe₃), 1.06, 1.10 (d, CH₃), 1.85-2.36 (m, CH), 3.40 (s, OCH₃), 4.02 (d, CHOSiMe₃); IR (neat) 2957 (s), 2896 (s), 2826 (s), 1248 (s), 840 (s), 1083 (s), 1039 (s) cm⁻¹.

Thermolysis of the Isopropyl-Substituted Dimer 3c.
Method A. A solution of isobutyrylsilane **1c** (0.5 g) in C₆D₆ (1 mL) was photolyzed for 3.5 h. The solvent was then removed and the residue dissolved in a minimal amount of *n*-pentane. An attempt was then made to separate the photoproducts **3c** and **4c** by preparative gas chromatography (OV-101 column operating at 230 °C). The major product isolated from the column was identified as the alkene **7**.

Method B. A solution of the dimer **3c** (100 mg) in C₆D₆ (5 mL) containing methanol (1.5 mL) and one drop of pyridine was refluxed for a total of 140 h. The solvents were removed under vacuum, and the major products, the alkene **7** and unreacted starting material, were isolated by using chromatography (80/20 hexanes/CH₂Cl₂; silica gel). 2,5-Dimethyl-3-(bis(trimethylsilyl)(trimethylsiloxy)silyl)-4-(trimethylsiloxy)-3-hexene (**7**): colorless oil; ¹H NMR δ 0.23, 0.26 (s, OSiMe₃), 0.28 ((SiMe₃)₂),

1.08, 1.33 (d, CH₃, *J* = 6.7 and 7.1 Hz, respectively), 2.34, 2.85 (sept, CH, *J* = 6.7 and 7.1 Hz, respectively); ¹³C NMR δ 0.07 (SiMe₃), 1.81, 3.08 (OSiMe₃), 21.84, 22.22 (CH(CH₃)₂), 28.56, 34.80 (CH(CH₃)₂), 118.63 (=C(CH(CH₃)₂)Si), 158.34 (=C(OSiMe₃)-CH(CH₃)₂); ²⁹Si NMR δ 6.04, 11.99 (OSiMe₃), -7.24 (Si(OSiMe₃)Si₂), -19.29 (SiMe₃); IR (neat) 2959 (s), 2898 (s), 1261 (s), 841 (s), 1078 (s), 1043 (s), 1597 (m), 1582 (m) cm⁻¹; MS, *m/e* (relative intensity) 447 (M⁺ - Me, 2), 389 (M⁺ - Me₃Si, 18), 190 ([((Me₃Si)(Me₃SiO)Si]⁺, 55), 279 (94).

Cophotolysis of Acetylsilane 1a with Tri-*n*-butyltin Hydride. **Experiment 1.** A solution of acetylsilane **1a** (90 mg, 0.31 mmol) and freshly distilled *n*-Bu₃SnH (0.1 mL, 0.37 mmol) in C₆D₆ (0.7 mL) was photolyzed for 2.5 h. The ratio of the products, linear dimer **4a**/tin hydride adduct **8**, was approximately 1/1 as determined by ¹H NMR spectroscopy.

Experiment 2. A solution of acetylsilane **1a** (50 mg, 0.17 mmol) and freshly distilled *n*-Bu₃SnH (0.7 mL, 2.6 mmol) in C₆D₆ (0.3 mL) was photolyzed for 3 h. The excess *n*-Bu₃SnH was removed by trap-to-trap distillation. The ratio of the products, linear dimer **4a**/tin hydride adduct **8**, was approximately 1/3 as determined by ¹H NMR spectroscopy.

The tin hydride adduct **8** could be isolated from either reaction mixture by preparative gas chromatography (5% OV-101 on Chromosorb G HP 80/100, operating at 250 °C).

(α -(Trimethylsiloxy)ethyl)bis(trimethylsilyl)(tri-*n*-butylstannyl)silane (**8**): colorless oil; ¹H NMR δ 0.15, 0.32, 0.36 (all s, SiMe₃), 0.80-1.79 (m, butyl and CH₃), 4.33 (q, CH, *J* = 7.3 Hz); ¹³C NMR δ 1.05, 1.88, 2.09 (Me₃Si), 10.24 (CH₂, ¹*J*(¹¹⁹Sn-¹³C) = 252.6 Hz), 30.71 (CH₂, ²*J*(¹¹⁹Sn-¹³C) = 17.9 Hz), 28.20 (CH₂, ³*J*(¹¹⁹Sn-¹³C) = 57.8 Hz), 13.90 (CH₃), 26.47 (CH₃CHOSiMe₃), 62.74 (CH₃CHOSiMe₃); ²⁹Si NMR δ 15.13 (OSiMe₃), -11.21 (SiMe₃, ²*J*(¹¹⁹Sn-²⁹Si) = 23.6 Hz), -11.73 (SiMe₃, ²*J*(¹¹⁹Sn-²⁹Si) = 23.5 Hz), -63.58 (SiSi₂Sn).

Acknowledgment. We are grateful to the Natural Science and Engineering Research Council for financial support and for a scholarship to K.M.B.

Registry No. **1a**, 60154-96-3; **1b**, 106821-57-2; **1c**, 106821-58-3; **1d**, 106821-59-4; **3c**, 106821-66-3; **3d**, 106821-68-5; **4a**, 60155-05-7; (*E*)-**4b**, 106821-64-1; (*Z*)-**4b**, 106821-65-2; **4c**, 106821-67-4; (*E*)-**4d**, 106821-69-6; (*Z*)-**4d**, 106821-70-9; **5**, 106821-60-7; **6**, 106821-61-8; **7**, 106821-62-9; **8**, 106821-63-0; *n*-Bu₃SnH, 688-73-3; Si(SiMe₃)₄, 4098-98-0; CH₃CH₂COCl, 79-03-8; (CH₃)₂CHCOCl, 79-30-1; PhCH₂COCl, 103-80-0; (Me₃Si)₃SiH, 1873-77-4.

Dehydrogenation of Alkanes to Arenes by Iridium Complexes

Robert H. Crabtree,* Charles P. Parnell, and Richard J. Uriarte

Department of Chemistry, Yale University, New Haven, Connecticut 06511

Received July 21, 1986

Dehydrogenation of cyclohexanes to arenes using [IrH₂(Me₂CO)₂(PAR₃)₂]SbF₆ without a solvent is described. The chlorinated solvents previously used for reactions of this type are shown to transfer chloride to the metal to give chloro-bridged binuclear species. P-C bond cleavage in the phosphines limits the efficiency of the alkane reactions, which seem to involve the interface between the crystal of iridium complex and the alkane. Their yield is found to be strongly dependent on the counterion used, SbF₆ being the best we have tried.

Alkane activation is an area of great current interest;¹ selective catalytic functionalization of alkanes is one important goal in this area.² We have looked at the approach of using ligand deficient low-valent metal complexes in

combination with a hydrogen acceptor.¹ These can stoichiometrically dehydrogenate alkanes and, as has been shown more recently, catalytically dehydrogenate alkanes to alkenes.^{3,4a,5} We found *tert*-butylethylene (tbe) to be

(1) Crabtree, R. H. *Chem. Rev.* **1985**, *85*, 245. Janowicz, A. H.; Bergman, R. G. *J. Am. Chem. Soc.* **1982**, *104*, 352.

(2) Groves, J. T.; Nemo, T. E. *J. Am. Chem. Soc.* **1981**, *103*, 2884.

(3) Baudry, D.; Ephritikine, M.; Felkin, H. *J. Chem. Soc., Chem. Commun.* **1982**, 606, 1980, 1243, 1983, 788. Baudry, D.; Ephritikine, M.; Felkin, H.; Zakrzewski, J. *J. Chem. Soc., Chem. Commun.* **1982**, 1235, *Tetrahedron Lett.* **1984**, 1283.

the best hydrogen acceptor that we tried,⁴ presumably because it rapidly dehydrogenates metal complexes but, being a poor ligand,⁶ it does not block the open sites formed in the dehydrogenation step.

We now report fully on the stoichiometric dehydrogenation of alkanes to arenes, a brief report of which has appeared.⁵

Results and Discussion

A surprising feature of our original alkane dehydrogenation chemistry based on $[\text{IrH}_2\text{S}_2\text{L}_2]^+$ (1, S = Me₂CO, L = PPh₃) (eq 1) is that it proceeds in chlorinated solvents.^{4b}

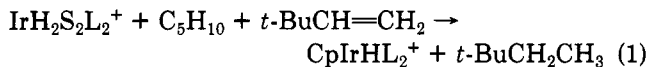

A species capable of attacking alkanes, it might be thought, would certainly far prefer to attack the C-Cl and C-H bonds of the C₂H₄Cl₂ solvent than the C-H bonds of the alkane. Some insight into this question was obtained from studying halocarbon complexes of iridium.⁷ These only undergo oxidative addition very slowly, if at all, when the complex is cationic but react at once when the metal center becomes more nucleophilic. The positive charge may therefore play a role in slowing the reaction of 1 with solvent that leads to deactivation. Presumably, the electrophilic nature of the metal inhibits C-Hal oxidative-addition mechanisms, such as single electron transfer and S_N2 attack.

In chlorinated solvents, cyclohexane did not react with 1. The proton NMR revealed several strong peaks in the hydride region of the crude product mixture. Suspecting that these hydrides might be formed by abstraction of HCl from the solvent, we added HCl to 1. The resulting NMR showed two sets of hydride resonances identical with ones that show up strongly in the crude mixture. We were able to fully characterize these products as isomers of $[(\text{IrHL}_2)_2(\mu\text{-Cl})_3]^+$ almost certainly having the structures 2a and 2b. The a:b ratios were different in different

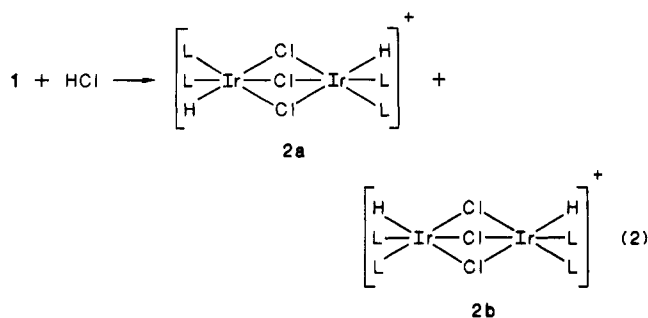

experiments (temperature, solvent, etc.), but both were always present. The ¹H NMR showed a triplet assigned to Ir-H at δ 23.1 for one isomer and at δ -24 for the other.

These complexes did not account for all the hydridic resonances in the crude product mixture. A species showing resonances at δ -23.3 (doublet of doublets, J = 16 and 20 Hz) and δ -11.9 (triplet of triplets, J = 10 and 62 Hz) proved to be identical with $[(\text{IrHL}_2)_2(\mu\text{-H})(\mu\text{-Cl})_2]^+$ (3) that we reported some years ago as the product of the

reaction of $[(\text{IrHL}_2)_2(\mu\text{-H})_3]^+$ with HCl.⁵

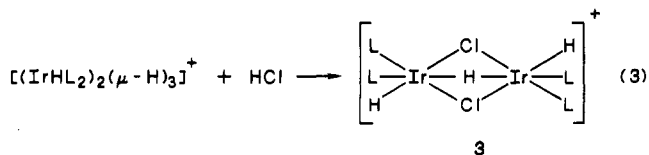

In all, complexes 2 and 3 account for some 40% of the products in the crude mixture. As 2 and 3 are inactive in alkane reactions, they can be considered as deactivation products formed by reaction with the solvent. They are also present, in lesser amount (ca. 15%) in the successful alkane reactions such as eq 1. This suggested that our original system is delicately balanced between reaction with alkane and reaction with chlorinated solvent. All that is required to tip the balance in favor of the chlorinated solvent is the use of a slightly less reactive alkane (e.g., cyclohexane or linear alkanes) as substrate.

This result made it clear that we should avoid chlorinated solvents. The simplest solution would be to use the substrate alkane itself as solvent. Unfortunately 1, as the BF₄ salt, has no measurable solubility in any alkane we have tried. Nevertheless we attempted a two-phase reaction in a glass pressure vessel, which can be sealed with a Teflon tap. The initial results were poor, although some alkane dehydrogenation product (ca. 1-5%) was always observed. Since the reaction presumably occurs at the surface of a crystallite of 1, we felt it would be worthwhile to examine different salts of 1 having different counterions, which might well have different mechanical and morphological properties in the crystalline form. Surprisingly, the SbF₆ salt 1a is very effective, in spite of its having no measurable alkane solubility. The reaction rate is further improved by grinding 1a to a fine powder before use and by magnetically stirring the contents of the sealed vessel with a small Teflon stir bar during the reaction.

It was surprising to us that these reactions worked well. Organometallic chemists normally choose solvents that dissolve their reactants. Here, we are limited to alkanes, in which the salts 1 were strictly insoluble. We verified this by attempting to extract the SbF₆ salt 1a with pentane in a Soxhlet apparatus over 7 days. If the compound had been reacting in solution, stirring the reaction vessel might not have been expected to have a large effect on the rate. It therefore seems to us that the reaction is taking place at the crystal surface⁸ and the rate may be dictated by the extent to which the product phase is mechanically removed from the surface of the crystallite to expose fresh reagent phase.

Under these conditions, not only did cyclopentane give a much improved yield of $[\text{CpIrHL}_2]^+$ (82%) but also methyl- and ethylcyclopentanes, previously completely unreactive, now gave the analogous $[(\text{RC}_5\text{H}_4)\text{IrHL}_2]^+$ (4) salts in good yield (R = Me (4a), 78%; R = Et (4b), 36%). The new compounds 4a and 4b were independently synthesized from the corresponding alkylcyclopentadienes and 1 in CH₂Cl₂. Complexes 4a and 4b are also obtained in essentially quantitative yield from the dienes after 30 min at 40 °C and from the monoenes after 6 h at 80 °C in refluxing 1,2-C₂H₄Cl₂. They were characterized by analytical and spectral data. In particular each complex shows a triplet resonance at δ -14.66 (4a) or -14.56 (4b) due to IrH. The alkyl side chain and the inequivalent pairs of cyclopentadienyl protons can also be clearly distinguished.

(8) Crabtree, R. H.; Felkin, H.; Morris, G. E. *J. Organomet. Chem.* 1977, 141, 205 describes another example of a reaction of related iridium complexes that takes place in the solid state.

(4) (a) Burk, M. J.; Crabtree, R. H.; McGrath, D. V. *J. Chem. Soc., Chem. Commun.* 1985, 1829. (b) Crabtree, R. H.; Mella, M. F.; Mihelcic, J. M.; Quirk, J. M. *J. Am. Chem. Soc.* 1982, 104, 107.

(5) Burk, M. J.; Crabtree, R. H.; Parnell, C. P.; Uriarte, R. *J. Organometallics* 1984, 3, 816.

(6) Green, M. A.; Huffman, J. C.; Caulton, K. G.; Rybak, W. K.; Ziolkowski, J. J. *J. Organomet. Chem.* 1981, 218, C39.

(7) Crabtree, R. H.; Faller, J. W.; Mella, M. F.; Quirk, J. M. *Organometallics* 1982, 1, 1361.

As mentioned above, cyclohexane failed to react at all in the chlorinated solvent. Under the new conditions, however, several dehydrogenation products were observed (eq 4). Among the products is free benzene. This is the

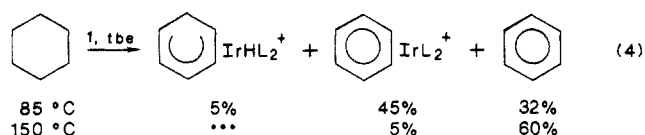

first time that arenes have been observed in an alkane activation system of the oxidative addition type. Shilov et al.⁹ have observed benzene in their electrophilic alkane chlorination system by using Pt(II) and Pt(IV) chloro complexes. In our system, the arene is the major product (60%) at high temperatures (150 °C). When the temperature was reduced, however, two organometallic species 5 and 6 become predominant. The first is an η^5 -cyclohexadienyl hydride and the second a simple η^6 -benzene complex. After considerable effort we were able to prepare both of these by independent synthesis from 1 (eq 5 and 6). This work is described in detail elsewhere.¹⁰ With

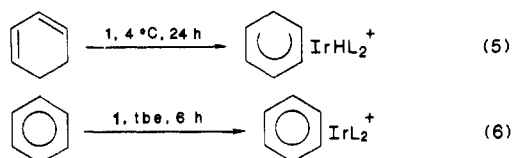

the two authentic complexes in hand, their identity with the compounds formed from cyclohexane was established by comparison of their ¹H and ³¹P NMR spectra. In no case did the combined yields of benzene + 5 + 6 exceed 65% (based on Ir); in other words, these reactions are never more than stoichiometric.

Clearly, 1 is a potential catalyst for the aromatization of cyclohexane. Why does the system fail to turn over catalytically? The answer to this question lies in two observations concerning the remaining products of reaction. First, at low temperature, the system does not release the alkane dehydrogenation product because the arene complex 6 is thermally stable to ca. 130 °C. Heating the reaction mixture to 135 °C or above does release the arene, but at these high temperatures, hydrogenolysis of phosphine P-C bonds also takes place, deactivating the system and liberating fluorobenzene. This product arises from the aromatic groups attached to phosphorus in the (*p*-FC₆H₄)₃P complexes that we used in this series of experiments. The P(*p*-tolyl)₃ complex gave toluene instead. The other product of such a hydrogenolysis should be an Ar₂P group. As a potentially bridging ligand, this group would be expected to form a phosphido-bridged cluster, a species very unlikely to be active in alkane dehydrogenation. In short, P-C cleavage should lead to deactivation. This is, we believe, what prevents this system from being authentically catalytic. Examination of the ³¹P NMR spectrum of the crude product mixture showed a number of peaks that might plausibly be assigned to bridging PAr₂ groups, although we have not yet been able to purify and characterize the products or synthesize them independently. This is probably because a mixture of similar species is formed.

P-C cleavage can be an important decomposition pathway for metal complexes of tertiary phosphines and has been observed even below room temperature and even in alkylphosphines. Yet such complexes are very widely

used in homogeneous catalysis. It is perhaps this reaction that limits the life of many phosphine-containing homogeneous catalysts. Garrou has reviewed this area recently and called attention to the problem.¹¹ The synthesis of P-C cleavage-resistant ligands constitutes an important and challenging problem for the future in homogeneous catalysis, but all our attempts to date¹ have been fruitless.

We have subsequently observed catalytic alkane dehydrogenation with a closely related system, but this is described elsewhere.^{4a}

Conclusion

We have shown how the chlorinated solvents previously used by us for alkane dehydrogenation limited the efficiency of the process by oxidizing the metal complex. Moving to alkane as solvent avoids this problem, but as the iridium complexes are not soluble in alkane, the reaction can be slow, presumably because it occurs at the crystal surfaces. Moving to a different counterion improved the rates and yields, but now a second deactivation process, P-C hydrogenolysis of the phosphines, took over.

Experimental Section

NMR spectra were recorded on Bruker WM-250 and WM 500 instruments. GC was performed on a Varian 920 (preparative) and 3700 (analytical, capillary column) instruments, and the identity of the compounds was confirmed by GC-MS (HP-6000). Chlorinated solvents were distilled from CaH₂ and olefins deperoxidized (Al₂O₃ column) and distilled before use. The standard Schlenk tube inert-atmosphere technique was used. Starting materials were prepared as previously described.¹²

Tris(μ -chloro)dihydridotetrakis(triphenylphosphine)diiridium(III) Hexafluoroantimonate. [IrH₂(Me₂CO)₂-(PPh₃)₂]SbF₆ (100 mg, 0.093 mmol) was stirred with excess concentrated HCl (0.2 mL) in CH₂Cl₂ (10 mL) for 10 min. The colorless mixture became deep yellow, the solvent was removed in vacuo, and the products were washed with H₂O (3 \times 10 mL) and then Et₂O (2 \times 10 mL). For removal of traces of Cl⁻ and HCl₂⁻ ion that had displaced the original SbF₆⁻, the crude product was dissolved in Me₂CO (10 mL) and stirred briefly with NaSbF₆ (0.1 g). The acetone was removed in vacuo, CH₂Cl₂ (5 mL) added, and the solution filtered. Addition of acetone and Et₂O to the filtrate gave light yellow microcrystals of the title complex (121 mg, 73%). Anal. Calcd for C₇₂H₈₂P₄Ir₂Cl₃SbF₆·0.66(CH₃)₂CO: C, 48.93; H, 3.55; P, 6.82; Cl, 5.86; F, 6.28. Found: C, 48.52; H, 3.68; P, 6.51; Cl, 5.90; F, 6.33. ¹H NMR [reported as position, multiplicity (coupling constant (Hz)), assignment] in CD₂Cl₂ at 25 °C: δ -23.1, t (19.5), Ir-H isomer 1; -24.0, t (19.5), Ir-H isomer 2; 7.2-7.9, c, aromatic.

Bis(μ -chloro)(μ -hydrido)dihydridotetrakis(triphenylphosphine)diiridium(III) Hexafluoroantimonate. IrH₅-(PPh₃)₂ (100 mg, 0.11 mmol) in CH₂Cl₂ (10 mL) was treated with concentrated HCl (0.2 mL). The yellow product was isolated as above. It was spectroscopically identical with the authentic complex, originally made by another route.⁸

Glass Pressure Vessel. We used a 10-mL glass vessel made of triple-thickness glass and equipped with a 3-mm Teflon vacuum stopcock. This was sealed under vacuum after the reagents and solvents had been introduced and degassed by freeze-thaw cycles on a vacuum line. It was heated to the reaction temperature in a thermostated aluminium block or an oil bath. The metal complex was ground to a fine powder before use, and the vessel was magnetically stirred with a Teflon coated stir bar. At the end of the reaction the volatiles were removed in vacuo to a trap cooled in liquid N₂. The volatile organic products were determined by GC and GC-MS and the involatile organometallic residues by ¹H NMR in CD₂Cl₂. The spectra of the latter were compared

(11) Garrou, P. *Chem. Rev.* **1985**, *85*, 171.

(12) Schrock, R. R.; Osborn, J. A. *J. Am. Chem. Soc.* **1971**, *93*, 2397. Crabtree, R. H.; Morris, G. E. *J. Organomet. Chem.* **1977**, *135*, 395. Crabtree, R. H.; Demou, P. C.; Eden, D.; Mihelcic, J. M.; Parnell, C.; Quirk, J. M.; Morris, G. E. *J. Am. Chem. Soc.* **1982**, *104*, 6994.

(9) Eskova, V. V.; Shilov, A. E.; Shteinman, A. A. *Kinet. Katal.* **1972**, *13*, 534.

(10) Crabtree, R. H.; Parnell, C. P. *Organometallics* **1985**, *5*, 519.

with the spectra of the authentic complexes independently prepared and characterized as described below.

Dihydrido(bis(acetone)bis(tris(*p*-fluorophenyl)phosphine)iridium(III) hexafluoroantimonate. $[\text{Ir}(\text{cod})\text{Cl}]_2$ (1.0 g, 1.5 mmol) and $\text{P}(\text{p-FC}_6\text{H}_4)_3$ (1.883 g, 5.95 mmol) were stirred with NaSbF_6 (1.6 g, 6.18 mmol) in MeOH (25 mL) for 24 h at room temperature. The solvent was then removed in vacuo, CH_2Cl_2 (30 mL) added, and the solution filtered to remove inorganic salts. The volume of the filtrate was reduced to 5 mL and Et_2O added to precipitate $[\text{Ir}(\text{cod})((\text{p-FC}_6\text{H}_4)_3\text{P})_2]\text{SbF}_6$ (3.02 g, 96%). $^1\text{H NMR}$ ($(\text{CD}_3)_2\text{CO}$): δ 2.04–2.4, complex, cod CH_2 ; 4.40, c, cod CH ; 7.2, c, ortho to P; 7.63, c, ortho to F. This complex was hydrogenated in 500-mg batches as follows. $[\text{Ir}(\text{cod})\text{L}_2]\text{SbF}_6$ (500 mg, 0.43 mmol) in acetone (7 mL) was cooled to 0 °C and H_2 bubbled through the vigorously stirred solution for 20 min. The solvent was reduced to ca. 5 mL in vacuo, and Et_2O (70 mL) and pentane (20 mL) were added to precipitate the cream-colored title complex. Recrystallization from CH_2Cl_2 (5 mL)– Me_2CO (0.5 mL) under H_2 with Et_2O (3.0 mL)–pentanes (15 mL) gave colorless crystals (418 mg, 91%). Anal. Calcd for $\text{C}_{42}\text{H}_{38}\text{O}_2\text{P}_2\text{F}_{12}\text{IrSb}$: C, 42.8; H, 3.22. Found: C, 42.78; H, 3.05. $^1\text{H NMR}$ (CD_2Cl_2): δ –27.6, t (16), Ir–H; 1.86, s, Me_2CO ; 7.28 and 7.61, c, Ar. The triphenylphosphine complex has been described and tri-*p*-tolylphosphine analogue was prepared in the same way as described above. L = (*p*- MeC_6H_4)₃: $^1\text{H NMR}$ (in $(\text{CD}_3)_2\text{CO}$ except for the coordinated Me_2CO resonance, which appears only in CD_2Cl_2) δ –27.9, t (16), Ir–H; 1.78, s, Me_2CO ; 2.39, s, MeAr; 7.29–7.35, c, Ar. Anal. Calcd for $\text{C}_{48}\text{H}_{56}\text{P}_2\text{O}_2\text{IrF}_6\text{Sb}$: C, 49.94; H, 4.85. Found: C, 50.20; H, 4.80.

Hydrido(alkylcyclopentadienyl)bis(triphenylphosphine)iridium(III) hexafluoroantimonate. $[\text{IrH}_2(\text{acetone})(\text{PPh}_3)_2]\text{SbF}_6$ (100 mg, 0.0934 mmol) was refluxed with the 1-alkylcyclopentene (or 3-alkylcyclopentene) (1 mL; R = Me or Et) in 1,2- $\text{C}_2\text{H}_4\text{Cl}_2$ (10 mL) for 6 h. The solution was cooled, the solvents were removed in vacuo, and the products were recrystallized from CH_2Cl_2 – Et_2O (R = Me, 82 mg, 85%; R = Et, 76 mg, 78%). A mixture of isomers of alkylcyclopentadienes gave the same products after only 30 min at 40 °C in CH_2Cl_2 (yield

95–97%). Anal. Calcd for $\text{C}_{42}\text{H}_{38}\text{P}_2\text{F}_6\text{SbIr}$: C, 48.86; H, 3.68. Found: C, 48.74; H, 3.75. Calcd for $\text{C}_{48}\text{H}_{56}\text{P}_2\text{F}_6\text{SbIr}$: C, 49.35; H, 3.82. Found: C, 49.09; H, 3.94. $^1\text{H NMR}$ (R = Me): δ –14.66, t (28), Ir–H; 1.86, s, Me; 5.11, 5.32, br, CH. $^1\text{H NMR}$ (R = Et): δ –14.56, t (28), Ir–H; 1.19, t (7), Me; 2.23, q (7), CH_2 ; 4.44 and 5.24, br, CH. The tris(*p*-fluorophenyl)phosphine complexes were prepared in the same way (yield 80%).¹⁰

(η^6 -Benzene)bis(tris(*p*-fluorophenyl)phosphine)iridium(I) hexafluoroantimonate was prepared by the method described in ref 10, for $[(\text{C}_6\text{H}_6)\text{Ir}(\text{PPh}_3)_2]\text{SbF}_6$, but with tris(*p*-fluorophenyl)phosphine; yield 80%. $^1\text{H NMR}$ (CD_2Cl_2): δ 6.1, s, C_6H_6 ; 7.2–7.6, c, PAr_3 . The toluene complex was made in the same way (yield 75%). $^1\text{H NMR}$ (CD_2Cl_2): δ 5.6, d (4), 1- and 5-H; 5.8, t (6), 2- and 4-H; 2.4, s, Me; 7.2–7.6, c, PAr_3 .

Acknowledgment. We thank Mark W. Davis for communicating some results on related systems. We also thank the National Science Foundation (C.P.P.), the Department of Energy (R.H.C.), and the donors of the Petroleum Research Fund, administered by the American Chemical Society, (R.J.U.), for support.

Registry No. 1-BF₄ (L = PPh₃), 72414-17-6; 1-SbF₆(L = PPh₃), 89509-77-3; 1-SbF₆(L = P(*p*-FC₆H₄)₃), 89529-62-4; 1-SbF₆(L = P(*p*-tolyl)₃), 106864-52-2; 2a-SbF₆, 106928-20-5; 2b-SbF₆, 106928-22-7; 3-SbF₆, 106880-36-8; 4a-SbF₆, 106864-47-5; 4b-SbF₆, 106864-49-7; [CpIrH(PPh₃)₂]₂SbF₆, 91410-26-3; [η^5 -C₆H₇]IrH(PPh₃)₂SbF₆, 91410-24-1; [(C₆H₆)IrH(PPh₃)₂]₂SbF₆, 94249-80-6; [(C₆H₆)IrH(P(*p*-tolyl)₃)₂]₂SbF₆, 106864-51-1; [(C₆H₆)Ir(P(*p*-FC₆H₄)₃)₂]₂SbF₆, 102533-91-5; IrH₃(PPh₃)₂, 53470-69-2; [Ir(cod)Cl]₂, 12112-67-3; [Ir(cod)((*p*-FC₆H₄)₃P)₂]₂SbF₆, 89509-87-5; *t*-BuCH=CH₂, 558-37-2; P(*p*-FC₆H₄)₃, 18437-78-0; cyclopentane, 287-92-3; methylcyclopentane, 96-37-7; ethylcyclopentane, 1640-89-7; methyl-1,3-cyclopentadiene, 26519-91-5; ethyl-1,3-cyclopentadiene, 26519-92-6; 1-methylcyclopentene, 693-89-0; 1-ethylcyclopentene, 2146-38-5; cyclohexane, 110-82-7; benzene, 71-43-2; 1,3-cyclohexadiene, 592-57-4; 3-methylcyclopentene, 1120-62-3; 3-ethylcyclopentene, 694-35-9.

Electrochemical and Chemical Generation of Novel Dianions from (η^6 : η^6 -Conjugated arene)bis(tricarbonylchromium) Complexes. Isolation and Spectroscopic Evidence for (η^5 : η^5 -Biphenyl)bis(tricarbonylchromium) Dianion

R. D. Rieke,* S. N. Milligan,¹ and L. D. Schulte

Department of Chemistry, University of Nebraska, Lincoln, Nebraska 68588-0304

Received August 5, 1986

Bis(tricarbonylchromium) complexes of arene compounds with two conjugated phenyl rings reduce electrochemically or chemically in a two-electron process to yield very stable dianions. The reduction process is proposed to proceed via an ECE mechanism generating a bis(η^5 -cyclohexadienyl)bis(tricarbonylchromium) complex. Infrared spectroscopy, $^1\text{H NMR}$, and $^{13}\text{C NMR}$ data support the proposed structure for the dianion produced from (η^6 : η^6 -biphenyl)bis(tricarbonylchromium). The electrochemical properties of the bis(tricarbonylchromium) complex of bimesityl provides an explanation for electrochemical reductive properties of all (η^6 -benzene)tricarbonylchromium complexes. Finally, the oxidative electrochemical properties of the mono and bis complexes are discussed.

Introduction

Since Dessy's original report on some of the redox properties of (η^6 -benzene)tricarbonylchromium^{2,3} our group⁴⁻⁹ and others¹⁰⁻¹⁵ have been interested in the elec-

trochemical properties of this important class of compounds. Dessy's report on (η^6 -benzene)tricarbonyl-

(4) Rieke, R. D.; Milligan, S. N.; Tucker, I.; Dowler, K. A.; Willeford, B. R. *J. Organomet. Chem.* 1981, 218, C25–C30.

(5) Rieke, R. D.; Tucker, I.; Milligan, S. N.; Wright, D. R.; Willeford, B. R.; Radonovich, L. J.; Eyring, M. W. *Organometallics* 1982, 1, 938–950.

(6) Milligan, S. N.; Rieke, R. D. *Organometallics* 1983, 2, 171–173.

(7) Rieke, R. D.; Arney, J. R.; Rich, W. E.; Willeford, B. R.; Poliner, B. S. *J. Am. Chem. Soc.* 1975, 97, 5951–5953.

(1) Present address: E. I. DuPont de Nemours Co., Circleville, OH.

(2) Dessy, R. E.; Stary, F. E.; King, R. B.; Waldrop, M. *J. Am. Chem. Soc.* 1966, 88, 471–476.

(3) Dessy, R. E.; King, R. B.; Waldrop, M. *J. Am. Chem. Soc.* 1966, 88, 5112–5117.