

Diphenyl(phenylethynyl)phosphine d⁶ [Rh(III), Ir(III), Ru(II)] Complexes: Preparation of Homo (μ-Cl)₂ and Hetero (μ-Cl)(μ-PPh₂C≡CPh) Bridged d⁶–d⁸ Compounds

Jesús R. Berenguer,[†] María Bernechea,[†] Juan Forniés,^{*,‡} Julio Gómez,[†] and Elena Lalinde^{*,†}

Departamento de Química-Grupo de Síntesis Química de La Rioja, UA-CSIC, Universidad de La Rioja, 26006, Logroño, Spain, and Departamento de Química Inorgánica, Instituto de Ciencia de Materiales de Aragón, Universidad de Zaragoza-Consejo Superior de Investigaciones Científicas, 50009 Zaragoza, Spain

Received January 24, 2002

The novel P-coordinated diphenyl(phenylethynyl)phosphine complexes [Cp^{*}MCl₂(PPh₂C≡CPh)] [M = Rh **1**, Ir **2**] have been prepared by the bridge splitting of [Cp^{*}MCl₂]₂ with PPh₂C≡CPh. Treatment of **1** and **2** with AgTfO and PPh₂C≡CPh affords the corresponding cationic compounds [Cp^{*}MCl(PPh₂C≡CPh)₂](OTf) [M = Rh **3**, Ir **4**, OTf = triflate], respectively. The analogous neutral Ru(II) derivative [Cp^{*}RuCl(PPh₂C≡CPh)₂] **5** has been obtained by reaction of PPh₂C≡CPh and the binuclear complex [Cp^{*}RuCl₂]₂ in the presence of Zn as the reductor. The molecular structures of **1** and **3–5** have been determined by single-crystal X-ray diffraction. The alkynyl fragments in cations **3** and **4** and in the neutral ruthenium derivative **5** are eclipsed, but the C_α···C_α interligand distances are longer than the minimal separation necessary (3.2–3.4 Å) to promote alkynyl coupling. The reactivity of these mono (**1**, **2**) and bis[diphenyl(phenylethynyl)phosphine] (**3–5**) complexes toward [cis-Pt(C₆F₅)₂(THF)₂] has been explored. Treatment of **1** with 1 equiv of [cis-Pt(C₆F₅)₂(THF)₂] in CH₂Cl₂ affords the doubly chloride bridged [(PPh₂C≡CPh)Cp^{*}Rh(μ-Cl)₂Pt(C₆F₅)₂] **6**. In contrast, the analogous iridium derivative [Cp^{*}IrCl₂(PPh₂C≡CPh)] **2** reacts with [cis-Pt(C₆F₅)₂(THF)₂], leading to a mixture of isomers [(PPh₂C≡CPh)Cp^{*}Ir(μ-Cl)₂Pt(C₆F₅)₂] **7a** and [Cp^{*}ClIr(μ-Cl)(μ-κP:η²-PPh₂C≡CPh)Pt(C₆F₅)₂] **7b** (**7a**/**7b** ≈ 2.5:1). Similar cationic [(PPh₂C≡CPh)Cp^{*}M(μ-Cl)(μ-κP:η²-PPh₂C≡CPh)Pt(C₆F₅)₂](OTf) [M = Rh **8**, Ir **9**] and neutral [(PPh₂C≡CPh)Cp^{*}Ru(μ-Cl)(μ-κP:η²-PPh₂C≡CPh)Pt(C₆F₅)₂] **10** hetero-bridged complexes are formed by treatment of the bis[diphenyl(phenylethynyl)]phosphine (**3–5**) complexes with [cis-Pt(C₆F₅)₂(THF)₂] in CH₂Cl₂. The structure of **10** has been confirmed by a single-crystal X-ray diffraction analysis.

Introduction

There is a rich and extensive chemistry derived from alkynylphosphines, PR'₂C≡CR, which are attractive due to their versatile behavior in coordination chemistry and reactivity. As polyfunctional ligands they have been fairly well explored and a wide range of polynuclear metal complexes have been prepared and studied.¹ The facility with which these ligands undergo a P–C(alkyne) bond cleavage process, acting as sources of acetylide (C≡CR) and phosphide (PR'₂) fragments on transition metal clusters, has also been well documented.² In some cases these fragments are further involved in coupling or insertion reactions with other coordinated organic ligands to give a range of new complexes in which phosphide and/or the acetylide groups have coupled with the organic species.³ The related coupling of an intact PR'₂C≡CR is uncommon,^{4a,b} but recent papers have shown that the insertion of alkynylidiphenylphosphines into reactive M–H or M–C of η²-benzyne or phosphi-

benzyne metal complexes is also a relatively easy process.^{4c–n}

Some previous experimental work⁵ and recent theoretical⁶ studies have demonstrated that simple P-coordination of phosphinoalkynes polarizes the C≡C electron density, concentrating electron density on the

- (1) (a) Went, M. J. *Polyhedron* **1995**, 465 and references therein. (b) Louattani E.; Suades, J. *J. Organomet. Chem.* **2000**, 604, 234. (c) Jeffery, J. C.; Pereira, R. M. S.; Vargas, M. D.; Went, M. J. *J. Chem. Soc., Dalton Trans.* **1995**, 1805. (d) Lang, H.; Weinmann, M.; Winter, M.; Leise, M.; Imhof, W. *J. Organomet. Chem.* **1995**, 503, 69. (e) Louattani, E.; Suades, J.; Alvarez-Larena, A.; Piniella J. F.; Germain, G. *J. Organomet. Chem.* **1996**, 506, 121. (f) Dickson, R. S.; Desimone, T.; Parker R. J.; Fallon, G. D. *Organometallics* **1997**, 16, 1531. (g) Imhof, W.; Eber, B.; Huttener G.; Emmeride, C. *J. Organomet. Chem.* **1993**, 447, 21. (h) Jones, D. F.; Dixneuf, P. H.; Southern, T. G.; Marouille, J.; Grandjean, D.; Guenot, P. *Inorg. Chem.* **1981**, 20, 3247. (i) Jacobson, S.; Carty, A. J.; Mathew, M.; Palenik, G. *J. Am. Chem. Soc.* **1974**, 96, 4330. (j) Carty, A. J.; Paik, H. N.; Ng, T. W. *J. Organomet. Chem.* **1974**, 74, 279. (k) Patel, H. A.; Carty, A. J.; Hota, N. K. *J. Organomet. Chem.* **1973**, 50, 247. (l) Hota, N. K.; Patel, H. A.; Carty, A. J.; Mathew, M.; Palenik, G. *J. Organomet. Chem.* **1971**, 32, C55. (m) Sappa, E.; Predieri, G.; Tiripicchio, A.; Tiripicchio-Camellini, M. *J. Organomet. Chem.* **1985**, 297, 103. (n) Carty, A. J.; Paik, H. N.; Palenik, J. G. *Inorg. Chem.* **1977**, 16, 300. (o) Carty, A. J.; Smith, W. F.; Taylor, N. J. *J. Organomet. Chem.* **1978**, 146, C1. (p) Carty, A. J.; Dimock, K.; Paik, H. N.; Palenik, G. *J. Organomet. Chem.* **1974**, 70, C17. (q) Bruce, M. I.; Williams, M. L.; Skelton, B. W.; White, A. H. *J. Organomet. Chem.* **1985**, 282, C53.

* Corresponding authors. E-mail: elena.lalinde@dq.unirioja.es; forniesj@posta.unizar.es.

[†] Universidad de La Rioja, UA-CSIC.

[‡] Universidad de Zaragoza-CSIC.

carbon atom bonded to P. Although it is clear that this fact activates the reactivity of the uncoordinated alkynyl function, particularly toward nucleophilic attacks, and could have important consequences in organic synthesis, it is rather surprising that literature on simple mononuclear complexes stabilized by P-coordinated alkynyl ligands is scarce.^{1b,4b,6,7}

As part of our interest in alkyne- and alkynide-containing platinum complexes, we have explored the η^2 -bonding capabilities of P-coordinated diphenylphosphinoalkyne complexes [*cis*-MX₂(PPh₂C≡CR)₂] with respect to the effect of chelation on activation and/or coupling reactions of both adjacent alkyne fragments.^{4a,b} We previously prepared the mononuclear platinum complexes [*cis*-Pt(C≡CR)₂(PPh₂C≡CR')₂] (R, R' = Ph, *t*-Bu)⁸ and examined their reactions with the solvento complexes *cis*-[M(C₆F₅)₂(THF)₂] (M = Pt, Pd; THF =

(2) (a) Carty, A. J. *Pure Appl. Chem.* **1982**, *54*, 113 and references therein. (b) Carty, A. J.; Taylor, N. J.; Smith, W. F. *J. Chem. Soc., Chem. Commun.* **1979**, 750. (c) Nuccianore, D.; MacLaughlin, S. A.; Taylor, N. J.; Carty, A. J. *Organometallics* **1988**, *7*, 106. (d) Cherkas, A. A.; Randall, L. H.; MacLaughlin, S. A.; Mott, G. N.; Taylor, N. J.; Carty, A. J. *Organometallics* **1988**, *7*, 969. (e) Bruce, M. I.; Williams, M. L.; Patrick, J. M.; White, A. H. *J. Chem. Soc., Dalton Trans.* **1985**, 1229. (f) Hogarth, G.; Richmond, S. P. *J. Organomet. Chem.* **1997**, *534*, 221.

(3) (a) Bobbie, B. J.; Taylor, N. J.; Carty, A. J. *J. Chem. Soc., Chem. Commun.* **1991**, 1511. (b) Sappa, E.; Pasquinelli, A.; Tiripicchio, A.; Tiripicchio Camellini, M. *J. Chem. Soc., Dalton Trans.* **1989**, 601. (c) Davies, J. E.; Mays, M. J.; Raithby, P. R.; Sarveswaran, K.; Shields, G. P. *J. Organomet. Chem.* **1999**, *573*, 180. (d) Davies, J. E.; Mays, M. J.; Raithby, P. R.; Sarveswaran, K.; Solan, G. A. *J. Chem. Soc., Dalton Trans.* **2001**, 1269. (e) Delgado, E.; Chi, Y.; Wang, W.; Hogarth, G.; Low, P. J.; Enright, G. D.; Peng, S.-M.; Lee, G.-H.; Carty, A. J. *Organometallics* **1998**, *17*, 2936. (f) Pereira, R. M. S.; Fujiwara, F. Y.; Vargas, M. D.; Braga D.; Crepioni, F. *Organometallics* **1997**, *16*, 4833. (g) Benvenuti, M. H.; Vargas, M. D.; Braga, D.; Crepioni, F.; Mann, B. E.; Taylor, S. *Organometallics* **1993**, *12*, 2947.

(4) (a) Carty, A. J.; Taylor, N. J.; Johnson, D. K. *J. Am. Chem. Soc.* **1979**, *101*, 5422. (b) Johnson, D. K.; Rukachaisirikul, T.; Sun, Y.; Taylor, N. J.; Carty, A. J.; Carty, A. J. *Inorg. Chem.* **1993**, *32*, 5544. (c) Bennett, M. A.; Cobley, Ch. J.; Rae, A. D.; Wenger, E.; Willis, A. C. *Organometallics* **2000**, *19*, 1522. (d) Edwards, A. J.; Macgregor, S. A.; Rae, A. D.; Wenger, E.; Willis, A. C. *Organometallics* **2001**, *20*, 2864. (e) Miquel, Y.; Cadierno, V.; Donnadieu, B.; Igau, A.; Mayoral, J. P. *Organometallics* **2000**, *19*, 54. (f) Miquel, Y.; Igau, A.; Donnadieu, B.; Mayoral, J. P.; Pirio, N.; Meunier, P. *J. Am. Chem. Soc.* **1998**, *120*, 3504. (g) Miquel, Y.; Igau, A.; Donnadieu, B.; Mayoral, J. P.; Dupuis, L.; Pirio, N.; Meunier, P. *Chem. Commun.* **1997**, 279. (h) Dupuis, L.; Pirio, N.; Meunier, P.; Igau, A.; Donnadieu, D.; Mayoral, J. P. *Angew. Chem., Int. Ed. Engl.* **1997**, *36*, 987. (i) Bennett, M. A.; Cobley, Ch. J.; Wengers, E.; Willis, A. C. *Chem. Commun.* **1998**, 1307. (j) Rosa, P.; Le Floch, P.; Ricard, L.; Mathey, F. *J. Am. Chem. Soc.* **1997**, *119*, 9417. (k) Dema, A. C.; Lukehart, Ch. M. *Inorg. Chim. Acta* **1997**, *264*, 193. (l) Li, X.; Lukehart, Ch. M. *Organometallics* **1992**, *11*, 3993. (m) Montlo, D.; Suades, J.; Dahan, F.; Mathieu, R. *Organometallics* **1990**, *9*, 2933. See also: (n) Davies, J. E.; Mays, M. J.; Raithby, P. R.; Sarveswaran, K.; Solan, G. A. *J. Chem. Soc., Dalton Trans.* **2000**, 3331.

(5) (a) Liu, X.; Mok, K. F.; Leung, P.-H. *Organometallics* **2001**, *20*, 3918. (b) Dickson, R. S.; De Simone, T.; Parker, R. J.; Fallon, G. D. *Organometallics* **1997**, *16*, 1531. (c) Simpson, R. T.; Jacobson, S. E.; Carty, A. J. *J. Chem. Soc., Chem. Commun.* **1973**, 388. (d) Carty, A. J.; Jacobson, S. E.; Simpson, R. T. *J. Am. Chem. Soc.* **1975**, *97*, 7254. (e) Carty, A. J.; Johnson, D. K.; Jacobson, S. E. *J. Am. Chem. Soc.* **1979**, *101*, 5612. (f) Taylor, N. J.; Jacobson, S. E.; Carty, A. J. *Inorg. Chem.* **1975**, *14*, 2648. See also ref 7d.

(6) (a) Louattani, E.; Lledos, A.; Suades, J.; Alvarez-Larena, A.; Piniella, F. *Organometallics* **1995**, *14*, 1053. See also: (b) Rossenberg, D.; Drenth, W. *Tetrahedron* **1971**, *27*, 3893. (c) Albright, T. A.; Freeman, W. J.; Schweizer, E. E. *J. Am. Chem. Soc.* **1975**, *97*, 2946.

(7) (a) Louattani, E.; Suades, J. *Inorg. Chim. Acta* **1999**, *291*, 207. (b) Louattani, E.; Suades, J.; Mathieu, R. *J. Organomet. Chem.* **1991**, *421*, 395. (c) Hengefeld, A.; Nast, R. *J. Organomet. Chem.* **1983**, *252*, 375. (d) Hemsall, H. D.; Hyde, E. M.; Mentzer, E.; Saw, B. L. *J. Chem. Soc., Dalton Trans.* **1997**, 2285. (e) Wong, Y. S.; Jacobson, S.; Chieh, P. C.; Carty, A. J. *Inorg. Chem.* **1974**, *13*, 284. (f) Wheelock, K. S.; Nelson, J. H.; Jonassen, M. B. *Inorg. Chim. Acta* **1970**, *4*, 399. (g) King, R. B.; Efraty, A. *Inorg. Chim. Acta* **1970**, *4*, 319. (h) Simpson, R. T.; Carty, A. J. *J. Coord. Chem.* **1973**, *2*, 207. (i) Bardaji, M.; Laguna, A.; Jones, P. G. *Organometallics* **2001**, *20*, 3906.

(8) Ara, I.; Falvello, L. R.; Fernandez, S.; Forniés, J.; Lalinde, E.; Martín, A.; Moreno, M. T. *Organometallics* **1997**, *16*, 5923.

tetrahydrofuran). A number of homo- and heterobimetallic complexes stabilized with double alkynyl bridging systems and unusual symmetrical [{"PPh₂C≡C-*t*-Bu)₂-Pt(μ_3 - η^2 -C≡CPh)₂}{M(C₆F₅)₂}]₂] and [{"Pt(μ - κ P: η^2 -PPh₂C≡CPh)₂(μ - η^2 -C≡C-*t*-Bu)₂}{Pt(C₆F₅)₂}]₂] trimetallic species were isolable by using 1:1 and 1:2 molar ratios, respectively, indicating the following order of bonding capability: C≡CR > P-bonded PPh₂C≡CR and C≡CPh units > C≡C-*t*-Bu fragments.⁸ The lower η^2 -bonding capability of PPh₂C≡C-*t*-Bu has been attributed to the higher steric demand of the bulky *t*-Bu group, and this is consistent with the earlier observation that the reaction of *cis*-[Pt(C₆F₅)₂(THF)₂] with [*cis*-PtCl₂(PPh₂C≡C-*t*-Bu)₂] yielded binuclear double chloride bridged complexes [(PPh₂C≡C-*t*-Bu)₂Pt(μ -Cl)₂Pt(C₆F₅)₂], while the unusual binuclear [(PPh₂C≡CPh)ClM(μ -Cl)(μ - κ P: η^2 -PPh₂C≡CPh)-Pt(C₆F₅)₂] derivatives could be prepared using the diphenyl(phenylethynyl)phosphine species as precursors.⁹ More recently we observed that by forcing the η^2 -complexation of both P-coordinated PPh₂C≡CPh molecules, on [*cis*-Pt(C₆F₅)₂(PPh₂C≡CPh)₂], the initial η^2 -alkyne adduct [{"(C₆F₅)₂Pt(μ - κ P: η^2 -PPh₂C≡CPh)₂}{Pt(C₆F₅)₂}] formed at low temperature evolves, through an unexpectedly easy sequential insertion of both PPh₂C≡CPh molecules, into a Pt–C₆F₅ bond, forming unusual μ -2,3-bis(diphenylphosphino)-1,3-butadien-1-yl binuclear complexes.¹⁰

Given the paucity of mononuclear complexes containing PPh₂C≡CR ligands and the interesting reaction chemistry observed with P-bonded PPh₂C≡CPh and the synthon "*cis*-Pt(C₆F₅)₂", we have extended our investigation to pentamethylcyclopentadienyl d^6 (Rh, Ir, and Ru) complexes containing P-coordinated PPh₂C≡CPh ligands. In this work we describe the synthesis and characterization of novel neutral [Cp* μ Cl₂(PPh₂C≡CPh)] (M = Rh, Ir), [Cp* μ RuCl₂(PPh₂C≡CPh)], and cationic [Cp* μ Cl(PPh₂C≡CPh)₂](OTf) (M = Rh, Ir) complexes with diphenyl(phenylethynyl)phosphine and examine their reactivity toward [*cis*-Pt(C₆F₅)₂(THF)₂]. The preparation of novel homo (μ -Cl)₂ and unprecedented hetero (μ -Cl)-(μ - κ P: η^2 -PPh₂C≡CPh) bridged d^6 – d^8 compounds is reported.

Results and Discussion

(i) Synthesis of Mononuclear Complexes (1–5).

Treatment of the binuclear complexes [Cp* μ Cl(μ -Cl)]₂ (M = Rh, Ir) with 2 equiv of PPh₂C≡CPh in acetone at room temperature affords the corresponding mononuclear complexes [Cp* μ Cl₂(PPh₂C≡CPh)] (M = Rh **1**, Ir **2**) (path i, Scheme 1), which are isolated as orange (**1**) or yellow (**2**) solids in high yield (~85%). As shown in Scheme 1 (path ii) the cationic complexes [Cp* μ Cl(PPh₂C≡CPh)₂](OTf) (M = Rh **3**, Ir **4**, OTf = triflate) were prepared as yellow crystalline solids by removing one of the chlorine ligands in **1** and **2** with silver triflate, followed by subsequent treatment with additional diphenyl(phenylethynyl)phosphine. All attempts to coordinate a third PPh₂C≡CPh ligand by removing both chlorine

(9) Forniés, J.; Lalinde, E.; Martín, A.; Moreno, M. T.; Welch, A. J. *J. Chem. Soc., Dalton Trans.* **1995**, 1333.

(10) Chartmant, J. P. H.; Forniés, J.; Gómez, J.; Lalinde, E.; Moreno, M. T.; Orpen, A. G.; Solano, S. *Angew. Chem., Int. Ed. Engl.* **1999**, *38*, 3058. (b) Ara, I.; Forniés, J.; García, A.; Gómez, J.; Lalinde, E.; Moreno, M. T. *Chem. Eur. J.*, in press.

Scheme 1

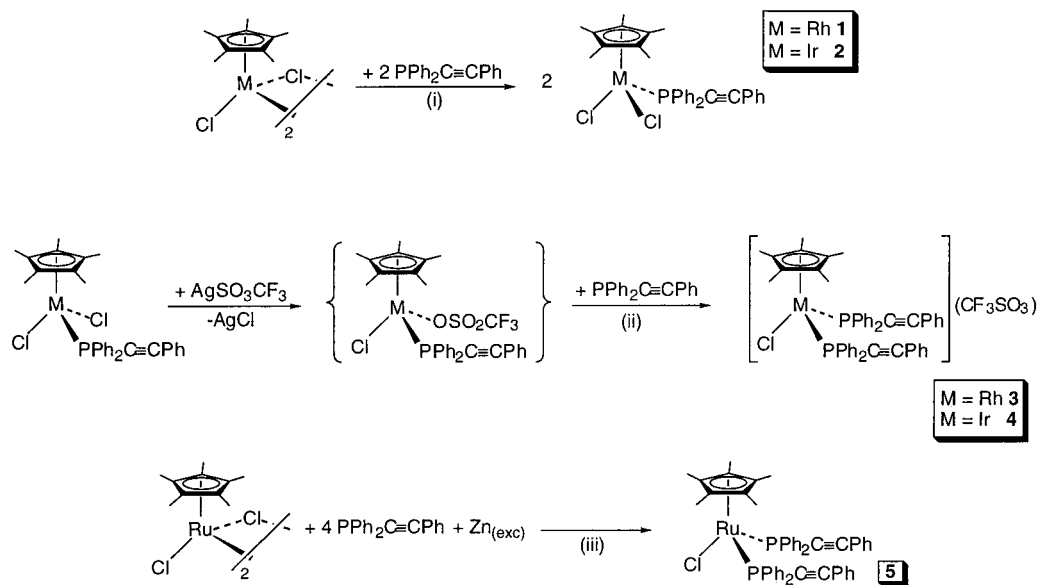
**Table 1.** ^{13}C Chemical Shifts (δ , ppm) of Acetylenic Carbons and Coupling Constants (Hz) in CDCl_3 of Compounds 1–5 Compared with Those of the Free Phosphine

	$\delta(\text{C}_\alpha)$	$^1J_{\text{C}_\alpha-\text{P}}$	$\delta(\text{C}_\beta)$	$^2J_{\text{C}_\beta-\text{P}}$	$\delta(\text{C}_\beta) - \delta(\text{C}_\alpha)$
$[\text{Rh}^{\text{III}}\text{Cp}^*\text{Cl}_2(\text{PPh}_2\text{C}\equiv\text{CPh})]$ (1)	81.3	90.5	109.4	11.9	28.1
$[\text{Ir}^{\text{III}}\text{Cp}^*\text{Cl}_2(\text{PPh}_2\text{C}\equiv\text{CPh})]$ (2)	80.1	104.2	107.4	14.6	27.3
$[\text{Rh}^{\text{III}}\text{Cp}^*\text{Cl}(\text{PPh}_2\text{C}\equiv\text{CPh})_2](\text{TfO})$ (3)	77.9	101.6	113.4	13.4 ^b	35.5
$[\text{Ir}^{\text{III}}\text{Cp}^*\text{Cl}(\text{PPh}_2\text{C}\equiv\text{CPh})_2](\text{TfO})$ (4)	77.8	116.8	111.5	16.1 ^b	33.7
$[\text{Ru}^{\text{II}}\text{Cp}^*\text{Cl}(\text{PPh}_2\text{C}\equiv\text{CPh})_2]$ (5)	85.8	77.5 ^a	106.9	10.5 ^b	21.1
$\text{PPh}_2\text{C}\equiv\text{CPh}$	86.5	6.6	109.4		22.9

^a $^1J_{\text{C}-\text{P}} + ^3J_{\text{C}-\text{P}}$ (AXX' system). ^b $^2J_{\text{C}-\text{P}} + ^4J_{\text{C}-\text{P}}$ (AXX' system).

groups in **1** or **2** in the presence of an excess of phosphine were unsuccessful. This failure could be presumably ascribed to steric hindrance about the metals in the final complexes. Initially, the related isoelectronic ruthenium neutral derivative $[\text{Cp}^*\text{RuCl}(\text{PPh}_2\text{C}\equiv\text{CPh})_2]$ **5** was obtained in very low yield ($\approx 10\%$) by the reaction of the Ru(III) $[\text{Cp}^*\text{RuCl}(\mu\text{-Cl})_2]$ complex with only 2 equiv of $\text{PPh}_2\text{C}\equiv\text{CPh}$. Similar reductions to bis(phosphine) derivatives $[\text{Cp}^*\text{RuCl}(\text{PR}_3)_2]$ have been observed previously in the presence of small phosphines such as PMe_3 .¹¹ However, the yield can be increased to ca. 40% by reduction of $[\text{Cp}^*\text{RuCl}(\mu\text{-Cl})_2]$ with Zn powder in acetone, in the presence of 4 equiv of (diphenylphosphino)alkyne (Scheme 1, iii). The product is isolated, by the usual workup, as an orange microcrystalline solid. In this context, it should be noted that Nelson et al. reported several years ago that the reaction of $[\text{CpRu}(\eta^1\text{-PPh}_2\text{CH}=\text{CH}_2)(\eta^3\text{-PPh}_2\text{CH}=\text{CH}_2)](\text{PF}_6)$ with $\text{RC}\equiv\text{CLi}$ ($\text{R} = \text{Ph}, t\text{-Bu}$) induces vinyl migration from phosphorus to ruthenium yielding $[\text{CpRu}(\eta^1\text{-PPh}_2\text{CH}=\text{CH}_2)(\text{PPh}_2\text{C}\equiv\text{CR})(\text{CH}=\text{CH}_2)]$ as the major product.¹²

All complexes are air-stable and have been characterized by the usual analytical and spectroscopic techniques. In addition, the molecular structures of the neutral derivatives **1** and **5**, and those of the cationic complexes **3** and **4**, have been confirmed by single-crystal X-ray diffraction. Moreover, conductivity mea-

surements in acetone solutions show that complexes **3** and **4** behave as 1:1 electrolytes.¹³ Evidence for the P-coordination mode of the $\text{PPh}_2\text{C}\equiv\text{CPh}$ ligand in all complexes comes from the infrared spectra, which show a strong (**1–3**) or medium (**4, 5**) $\nu(\text{C}\equiv\text{C})$ band in the 2169–2178 cm^{-1} region. Only small changes are observed in the position of this band when going from the neutral derivatives $[\text{Cp}^*\text{MCl}_2(\text{PPh}_2\text{C}\equiv\text{CPh})]$ ($\text{M} = \text{Rh}$ **1**, Ir **2**) to the cationic species $[\text{Cp}^*\text{MCl}(\text{PPh}_2\text{C}\equiv\text{CPh})_2]^+$ ($\text{M} = \text{Rh}$ **3**, Ir **4**), providing further support for a previous suggestion^{1b,7a} based on theoretical calculations,⁶ which relates the increase of the $\nu(\text{C}\equiv\text{C})$ of phosphinoalkynes after P-coordination to a metal center with the lesser delocalization of the phosphorus lone pair on the π^* $\text{C}\equiv\text{C}$ orbitals. Cationic complexes **3** and **4** also contain the characteristic stretching bands of the CF_3SO_3^- anion (see Experimental Section). Significantly, the observed singlet (**2, 4, 5**) or doublet ($^1J_{\text{P}-\text{Rh}}$ 147.8 Hz **1**, 140.8 Hz **3**) phosphorus resonances are, as expected,^{6–9} downfield shifted with respect to that of the free $\text{PPh}_2\text{C}\equiv\text{CPh}$ ($\delta -33.55$). The higher coordination shifts appear in complexes containing second-row atoms, and this is particularly observed in the ruthenium(II) complex ($\Delta(\text{Hz})$ 53.65 **5**, 37.85 **1**, 35.85 **3** vs 7.75 **2**, 1.25 **4**). Furthermore, the presence of the uncoordinated alkyne fragments is clearly inferred from ^{13}C NMR spectroscopy, which exhibits the acetylenic carbon resonances in the typical shift ranges. As can be observed in Table 1, in all complexes the C_α carbon resonances are upfield shifted with regard to that of free $\text{PPh}_2\text{C}\equiv\text{CPh}$

(11) (a) Tilley, T. D.; Grubbs, R. H.; Bercaw, J. E. *Organometallics* **1984**, *3*, 274. (b) Arligui, T.; Border, C.; Chaudret, B.; Devillers, J.; Poilblanc, R. *Organometallics* **1989**, *8*, 1308.

(12) Ji, H.; Nelson, J. H.; Decian, A.; Fischer, J.; Solujic, L.; Milosavljevic, E. B. *Organometallics* **1992**, *11*, 401.

(13) Geary, W. J. *Coord. Chem. Rev.* **1971**, *7*, 81.

Table 2. Crystallographic Data for 1·2CHCl₃, 3, 4, 5·1.55CH₂Cl₂, and 10

	1	3	4	5	10
empirical formula	C ₃₂ H ₃₂ Cl ₈ PRh	C ₅₄ H ₅₁ ClF ₃ O ₄ P ₂ RhS	C ₅₄ H ₅₁ ClF ₃ IrO ₄ P ₂ S	C _{51.55} H _{48.10} Cl _{4.10} P ₂ Ru	C ₆₂ H ₄₅ ClF ₁₀ P ₂ PtRu
fw	834.06	1053.31	1142.60	975.96	1373.53
temp (K)	293(2)	293(2)	173(1)	173(1)	120(1)
cryst syst	orthorhombic	triclinic	triclinic	orthorhombic	triclinic
space group	<i>P</i> 2 ₁ 2 ₁ 2 ₁	<i>P</i> $\bar{1}$	<i>P</i> $\bar{1}$	<i>P</i> <i>naa</i>	<i>P</i> $\bar{1}$
<i>a</i> (Å)	9.7070(1)	11.0958(2)	11.0540(2)	14.7963(2)	11.1445(1)
<i>b</i> (Å)	14.9200(2)	15.4035(3)	15.2321(2)	24.1042(5)	12.7015(2)
<i>c</i> (Å)	24.9810(4)	16.0011(4)	15.9130(4)	26.3309(5)	19.8127(3)
α (deg)	90	96.5045(8)	96.2500(6)	90	101.7740(6)
β (deg)	90	98.9757(9)	98.5577(7)	90	104.3562(6)
γ (deg)	90	109.2757(10)	109.6825(11)	90	96.6820(9)
vol (Å ³)	3617.96(8)	2509.75(9)	2458.09(8)	9391.0(3)	2618.24(6)
<i>Z</i>	4	2	2	8	2
<i>D</i> _{calcd} (Mg/m ³)	1.531	1.394	1.544	1.381	1.742
abs coeff (mm ⁻¹)	1.129	0.554	2.935	0.670	3.147
<i>F</i> (000)	1680	1084	1148	4009	1352
θ range for data collection (deg)	5.22–26.37	2.14–25.67	1.31–27.91	2.29–26.49	4.12–26.37
no. of data/restraints/params	7124/6/413	9514/0/602	11692/0/602	9575/6/561	10633/0/699
GOF on <i>F</i> ²	1.125	1.134	1.095	1.597	1.146
final <i>R</i> indices [<i>I</i> > 2 σ (<i>I</i>)]	<i>R</i> 1 = 0.0462, w <i>R</i> 2 = 0.1090	<i>R</i> 1 = 0.0541, w <i>R</i> 2 = 0.1247	<i>R</i> 1 = 0.0374, w <i>R</i> 2 = 0.0797	<i>R</i> 1 = 0.0584, w <i>R</i> 2 = 0.1609	<i>R</i> 1 = 0.0343, w <i>R</i> 2 = 0.0607
<i>R</i> indices (all data)	<i>R</i> 1 = 0.0626, w <i>R</i> 2 = 0.1155	<i>R</i> 1 = 0.0917, w <i>R</i> 2 = 0.1396	<i>R</i> 1 = 0.0535, w <i>R</i> 2 = 0.0849	<i>R</i> 1 = 0.0821, w <i>R</i> 2 = 0.1694	<i>R</i> 1 = 0.0506, w <i>R</i> 2 = 0.0640
largest diff peak and hole (e ⁻ Å ⁻³)	0.542 and -0.628	0.491 and -0.531	1.002 and -1.563	0.954 and -0.668	0.864 and -0.619

CPh ($\delta(C_{\alpha})$ 86.5). This effect is particularly significant in the cationic complexes **3** and **4**. In contrast to this, the acetylenic C_{β} carbon resonances clearly move downfield in the cationic complexes **3** and **4** and slightly upfield in the neutral ones (**1**, **2**, **5**). Consequently, the chemical shift differences ($\delta(C_{\beta}) - \delta(C_{\alpha})$), which have been previously related to the triple-bond polarization,^{2a,6} are perceptibly higher in the cationic complexes **3** and **4** than in the neutral derivatives (**1**, **2**). Interestingly, in the ruthenium neutral compound **5** the acetylenic carbon resonances lie very close to those of the free ligand. According to the data in Table 1 it is apparent that alkyne polarization is slightly enhanced in the neutral M(III) (Rh, Ir) compounds (**1**, **2**), and strongly increased in the cationic M⁺(III) (Rh, Ir) species (**3**, **4**). However, complexation of two PPh₂C≡CPh molecules to the “RuCp*Cl” fragment seems to have little influence on alkyne polarization. In complexes containing two PPh₂C≡CPh ligands (**3**, **4**, and **5**) the ¹³C signals due to the phenyl rings bonded to phosphorus are observed to be magnetically inequivalent, probably because of the hindered rotation across the M–P bonds.

The structures of **1** and **3**–**5** were determined by single-crystal X-ray diffraction studies. Details of the crystallographic determinations are indicated in Table 2. An ORTEP view of the neutral monophosphine complex is shown in Figure 1, and selected bond distances and angles are given in Table 3. Complex **1** shows a pseudooctahedral geometry around the rhodium atom, which is bonded to the pentamethylcyclopentadienyl group (η^5 -), the two chlorine atoms, and the phosphorus atom of the PPh₂C≡CPh ligand. The two Rh–Cl (2.4017(14), 2.4127(14) Å) and the Rh–P (2.3150(12) Å) bond lengths are comparable to those found in other rhodium(III) complexes.¹⁴ The presence of the uncoordinated alkynyl portion in the phosphine ligand is confirmed by P(1), C(11), C(12), and C(13)

Table 3. Selected Bond Lengths (Å) and Angles (deg) for [RhCp*Cl₂(PPh₂C≡CPh)]

Rh(1)–C(Cp*)	2.149(5)–2.220(5)	Rh(1)–C(2)	2.182(5)
Rh(1)–Cl(1)	2.4127(14)	Rh(1)–Cl(2)	2.4017(14)
Rh(1)–P(1)	2.3150(12)	P(1)–C(11)	1.750(5)
C(11)–C(12)	1.209(7)		
P(1)–Rh(1)–Cl(1)	91.34(5)	P(1)–Rh(1)–Cl(2)	89.75(5)
Cl(2)–Rh(1)–Cl(1)	92.38(6)	C(11)–P(1)–Rh(1)	111.41(16)
C(12)–C(11)–P(1)	175.0(5)	C(11)–C(12)–C(13)	178.6(6)

displaying a virtually linear geometry and the C(11)–C(12) bond distance being 1.209(7) Å, which is typical of a C≡C bond. The least sterically demanding alkynyl fragment is oriented toward the bulky pentamethylcyclopentadienyl ligand, a feature which has been also found in [CpFe(CO)₂PPh₂C≡CPh].^{6a} The structures of the cationic part of the bis(phosphine) compounds **3** and **4** and the molecular structure of the neutral ruthenium complex are quite similar; ORTEP diagrams are shown in Figure 2, and some characteristic bond lengths and angles are provided in Table 4. The two cations in **3** (Rh) and **4** (Ir) and the neutral molecule in **5** (Ru)

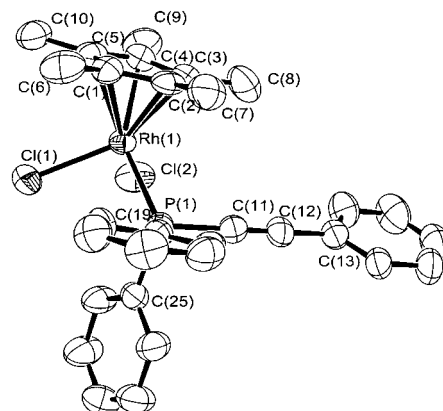
**Figure 1.** ORTEP view of [Cp*RhCl₂(PPh₂C≡CPh)] **1**. Ellipsoids are drawn at the 50% probability level. Hydrogen atoms have been omitted for clarity.

(14) Dromi, D.; Arena, C. G.; Nicolo, F.; Bruno, G.; Faraone, F. *J. Organomet. Chem.* **1995**, *485*, 115 and references therein.

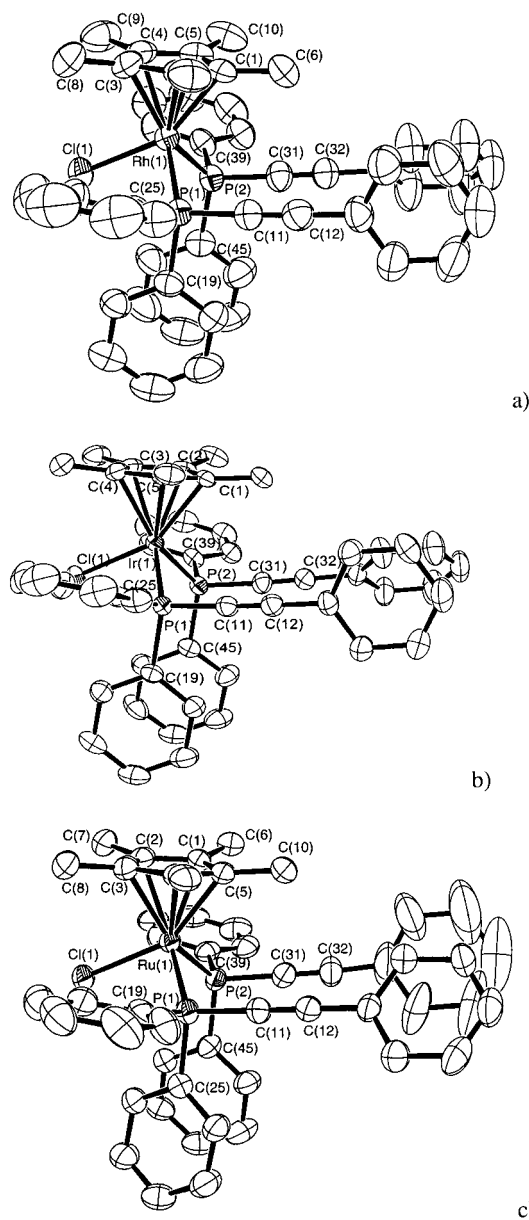

Figure 2. Molecular structure of (a) the cation $[\text{Cp}^*\text{RhCl}(\text{PPh}_2\text{C}\equiv\text{CPh})_2]^+$ in **3**, (b) the cation $[\text{Cp}^*\text{IrCl}(\text{PPh}_2\text{C}\equiv\text{CPh})_2]^+$ in **4**, and (c) $[\text{Cp}^*\text{RuCl}(\text{PPh}_2\text{C}\equiv\text{CPh})_2]^+$ **5**. Ellipsoids are drawn at the 50% probability level. Hydrogen atoms have been omitted for clarity.

display the expected three-legged geometry about the metal consistent with the spectral data. The M–Cl and M–P distances and the P–M–P and P–M–Cl angles are unexceptional for these types of metals and ligands.¹⁵ In the cation **3**⁺ the Rh–C(Cp*) (2.197(4)–2.292(4) Å) and the Rh–P (2.3159(10), 2.3357(11) Å) bond lengths are slightly longer than those observed in **1**, but compare well with the values reported for other related cationic complexes, such as $[\text{Cp}^*\text{RhCl}(\text{PPh}_2\text{C}\equiv\text{CPh})_2]^+$.

(15) For Rh: (a) Eisen, M. S.; Haskel, A.; Chen, H.; Olmstead, M. M.; Smith, D. P.; Maestre, M. F.; Fish, R. H. *Organometallics* **1995**, *14*, 2806. (b) Barthel-Rosa, L. P.; Catalano, V. J.; Maitra, K.; Nelson, J. H. (c) Carmona, D.; Lahoz, F. J.; Oro, L.; Lamata, M. P.; Viguri, F.; San Jose, E. *Organometallics* **1996**, *15*, 2961. For Ir: (d) Atherton, M. J.; Faweett, J.; Holloway, J. H.; Hope, E. G.; Karacar, A.; Russell, D.; Saunders, G. C. *J. Chem. Soc., Dalton Trans.* **1997**, 1811. For Ru: (e) de los Rios, I.; Jimenez Tenorio, M. J.; Puerta, M. C.; Valerga, P. *Organometallics* **1998**, *17*, 4392.

$\text{CH}=\text{CH}_2)_2]^+$.¹⁴ Despite the different polarization of the alkyne portions in these P-coordinated phosphinoalkyne compounds, suggested by ¹³C NMR spectroscopy, the chemically equivalent P–C(alkyne) bond distances in both cations **3**⁺ and **4**⁺ and in the ruthenium complex **5** are identical within experimental error and comparable to that seen in **1**. The most striking feature of these structures is the fact that both alkynyl entities are essentially eclipsed (dihedral angle between both P–C_α–C_β–C_γ fragments: 0.1° **3**⁺, 0.7° **4**⁺, 0.9° **5**) and located, as in **1**, close to the Cp* rings. However, the separation between the alkyne termini (C_α⋯C_α) is quite long: 3.8 and 3.76 Å in cations **3**⁺ and **4**⁺, respectively, and 3.776 Å in the neutral derivative (**5**). These values are long compared to those previously found in square-planar *cis*-bis[diphenyl(alkynyl)phosphine]platinum(II) complexes, such as $[\text{cis-PtCl}_2(\text{PPh}_2\text{C}\equiv\text{CPh})_2]$ (3.110(10) Å)^{4b} and $[\text{cis-Pt}(\text{C}_6\text{F}_5)_2(\text{PPh}_2\text{C}\equiv\text{CPh})_2]$ (3.194 Å),^{10b} in which intramolecular coupling of the phosphinoalkyne ligands was induced on heating.^{4b}

(ii) Synthesis of Heterobinuclear Pt(II)–M(d⁶) Complexes. As we noted in the Introduction, in the course of our ongoing research on phosphinoalkynyl platinum complexes we have recently observed an unexpected easy sequential insertion of both $\text{PPh}_2\text{C}\equiv\text{CR}$ molecules (R = Ph, Tol) into the very robust Pt–C₆F₅ bond simply by treating the *cis*-bis(phosphinoalkynyl)-platinum or palladium(II) complexes $[\text{cis-M}(\text{C}_6\text{F}_5)_2(\text{PPh}_2\text{C}\equiv\text{CR})_2]$ (THF = tetrahydrofuran). As a continuation of our work in this field we decided to examine the reactivity of **1–5** toward $[\text{cis-Pt}(\text{C}_6\text{F}_5)_2(\text{THF})_2]$. The results of these reactions are summarized in Schemes 2 and 3. Reaction of the dichloro rhodium complex **1** with 1 equiv of $[\text{cis-Pt}(\text{C}_6\text{F}_5)_2(\text{THF})_2]$ yields the corresponding dichloro-bridged heterobinuclear complex $[(\text{PPh}_2\text{C}\equiv\text{CPh})\text{Cp}^*\text{Rh}(\mu\text{-Cl})_2\text{Pt}(\text{C}_6\text{F}_5)_2]$ **6** in high yield (76%). Elemental analysis and IR ($\nu(\text{C}\equiv\text{C})$ 2167 cm⁻¹; $\nu(\text{Rh}-\text{Cl})_{\text{bridging}}$ 280, 267 cm⁻¹) and NMR (¹H, ¹³C, ¹⁹F, and ³¹P) spectroscopic data are in accordance with a symmetrical double chloride bridged compound with the $\text{PPh}_2\text{C}\equiv\text{CPh}$ molecule acting as a terminal P-coordinated ligand. The particularly relevant features are (a) the presence of a doublet phosphorus resonance (¹J_{Rh–P} = 149.0 Hz), which is found at a chemical shift close to the value shown in the precursor (δ 7.2 in **6** vs 4.3 in **1**), and (b) the existence, even at low temperature (–80 °C in CD₃COCD₃), of only one set of C₆F₅ resonances, confirming that both C₆F₅ ligands bound to platinum are equivalent. It is worth noting that although both acetylenic carbon resonances C_α (δ 83.3) and C_β (δ 116.7) are shifted to higher frequencies in relation to the precursor (δ C_α 81.3; C_β 109.4), the resulting chemical shift difference $\delta(\text{C}_\alpha) - \delta(\text{C}_\beta)$ increases to 33.4 ppm, implying a higher alkyne polarization in the binuclear complex **6** than in **1**. It should also be mentioned that although complex **6** belongs to the still uncommon family of d⁶–d⁸ heterobinuclear compounds, several neutral $[(\text{PEt}_3)_3\text{Cp}^*\text{M}(\mu\text{-Cl})_2\text{M}'(\text{C}_6\text{F}_5)_2]$ (M = Rh, Ir; M' = Pt, Pd)^{16a} and even cationic $[(\text{PMe}_3)_3\text{Cp}^*\text{M}(\mu\text{-Cl})_2\text{PtL}_2](\text{OTf})_2$ (M = Rh, Ir; L₂ = dppe, 2PPh₃)^{16b} complexes have been previously reported. In

(16) (a) Ara, I.; Berenguer, J. R.; Eguizabal, E.; Forniés, J.; Lalinde, E.; Martín, A. *Eur. J. Inorg. Chem.* **2001**, 1631. (b) Stang, P. J.; Huang, Y.-H.; Arif, A. M. *Organometallics* **1992**, *11*, 23.

Scheme 2

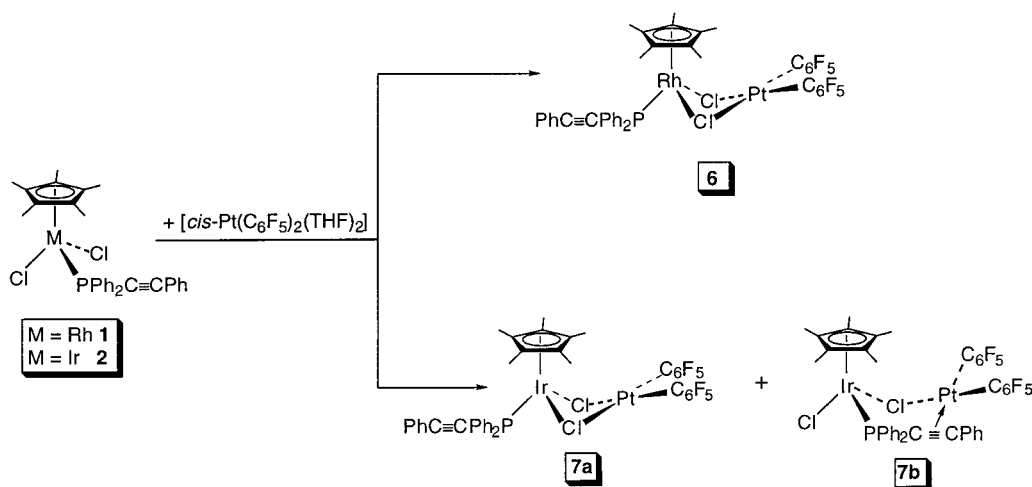

Scheme 3

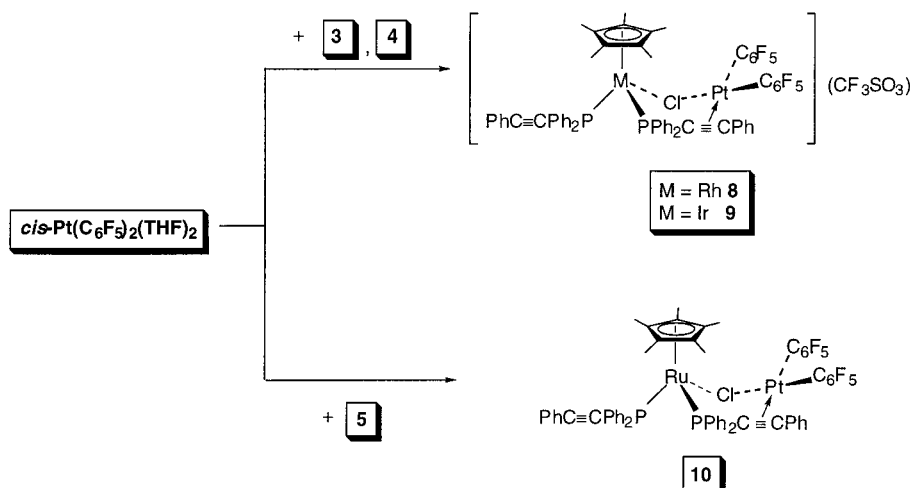
Table 4. Selected Bond Lengths (Å) and Angles (deg) for [MCp*Cl(PPh₂C≡CPh)₂] (M = Rh **3**, Ir **4**, Ru **5**)

	3		4		5	
M–Cp*	Rh(1)–C	2.197(4)–2.262(4)	Ir(1)–C	2.208(3)–2.284(4)	Ru(1)–C	2.208(4)–2.259(4)
M–Cl	Rh(1)–Cl(1)	2.4048(11)	Ir(1)–Cl(1)	2.4115(9)	Ru(1)–Cl(1)	2.4649(9)
M–P	Rh(1)–P(1)	2.3159(10)	Ir(1)–P(1)	2.2946(9)	Ru(1)–P(1)	2.2811(11)
	Rh(1)–P(2)	2.3357(11)	Ir(1)–P(2)	2.3123(10)	Ru(1)–P(2)	2.2810(10)
P–C _α	P(1)–C(11)	1.742(5)	P(1)–C(11)	1.753(4)	P(1)–C(11)	1.772(4)
	P(2)–C(31)	1.759(5)	P(2)–C(31)	1.762(4)	P(2)–C(31)	1.757(4)
C _α –C _β	C(11)–C(12)	1.201(6)	C(11)–C(12)	1.199(5)	C(11)–C(12)	1.193(5)
	C(31)–C(32)	1.191(6)	C(31)–C(32)	1.191(5)	C(31)–C(32)	1.212(5)
P–M–P	P(1)–Rh(1)–P(2)	94.59(4)	P(1)–Ir(1)–P(2)	94.51(3)	P(1)–Ru(1)–P(2)	93.28(4)
P–M–Cl	P(1)–Rh(1)–Cl(1)	91.25(4)	P(1)–Ir(1)–Cl(1)	91.26(3)	P(1)–Ru(1)–Cl(1)	95.06(3)
	P(2)–Rh(1)–Cl(1)	93.62(4)	P(2)–Ir(1)–Cl(1)	93.98(3)	P(2)–Ru(1)–Cl(1)	93.03(3)
C _α –P–M	C(11)–P(1)–Rh(1)	111.61(15)	C(11)–P(1)–Ir(1)	111.86(13)	C(11)–P(1)–Ru(1)	113.35(14)
	C(31)–P(2)–Rh(1)	110.32(15)	C(31)–P(2)–Ir(1)	110.26(13)	C(31)–P(2)–Ru(1)	112.79(15)
C _β –C _α –P	C(12)–C(11)–P(1)	178.1(4)	C(12)–C(11)–P(1)	178.1(4)	C(12)–C(11)–P(1)	176.1(4)
	C(32)–C(31)–P(2)	177.9(5)	C(32)–C(31)–P(2)	177.2(4)	C(32)–C(31)–P(2)	175.5(5)
C _α –C _β –C _γ	C(11)–C(12)–C(13)	177.3(5)	C(11)–C(12)–C(13)	177.1(4)	C(11)–C(12)–C(13)	177.6(5)
	C(31)–C(32)–C(33)	178.1(5)	C(31)–C(32)–C(33)	178.3(4)	C(31)–C(32)–C(33)	176.1(6)

contrast to complex **1**, the iridium complex **2** reacts with [cis-Pt(C₆F₅)₂(THF)₂] to yield a yellow solution, from which a microcrystalline yellow solid of the expected stoichiometry [(PPh₂C≡CPh)Cp*IrCl₂Pt(C₆F₅)₂] **7** can be isolated in good yield. The spectroscopic analysis of this solid reveals that it consists of a mixture of two isomers **7a** and **7b** in, approximately, 2.5:1 molar ratio. Their formulations, deduced from IR and NMR (¹H, ³¹P, and ¹⁹F) parameters, are those represented in Scheme 2. The

presence of terminal ($\nu(\text{C}\equiv\text{C})$ 2171 cm⁻¹ **7a**) and bridging ($\nu(\text{C}\equiv\text{C})$ 1960 cm⁻¹ **7b**) PPh₂C≡CPh ligands in the mixture is inferred not only from the IR data but also from the ³¹P NMR spectroscopy. Thus, the minor isomer (**7b**) shows a singlet resonance at δ 19.7, which is nearly 46 ppm shifted with respect to that of **2**. This shift, which is related to the loss of the electron ring current associated with the π C≡C bonds upon complexation, has been previously observed in other complexes con-

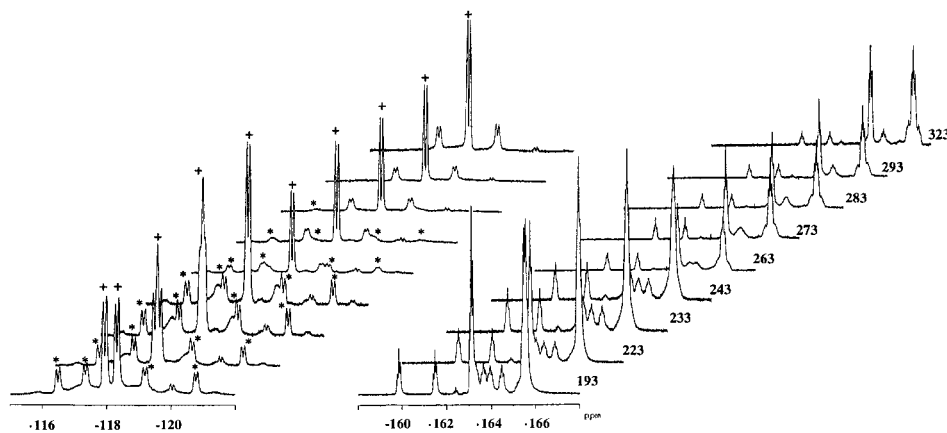

Figure 3. Variable-temperature ^{19}F NMR spectra of **7** (**7a** (+) + **7b** (*)) in CD_3COCD_3 .

taining $\mu\text{-}\kappa\text{P}:\eta^2\text{-PPh}_2\text{C}\equiv\text{CPh}$ bridging ligands.^{1b,8–10} A singlet at $\delta -12.4$ was attributed to the major isomer (**7a**) stabilized by chloride bridges and containing P-bonded $\text{PPh}_2\text{C}\equiv\text{CPh}$. The position of both signals is not temperature dependent, but the **7a/7b** molar ratio decreases by cooling, being $\approx 3.8:1$ at 323 K and only 2:1 at 193 K. This variation, which is also found in the ^1H and ^{19}F NMR spectra, suggests that the mixture is an equilibrium of both isomers. However, the presence of separated patterns, even at high temperature, indicates that the exchange between both isomers is very slow on the NMR time scale. This behavior is clearly revealed by ^{19}F NMR spectroscopy, which shows the two expected sets of signals, each one showing its typical temperature-dependent pattern (see Figure 3). As can be observed in Figure 3, the limiting low-temperature spectrum is compatible with a static structure for both isomers. **7a** exhibits a set of five distinct signals confirming that both C_6F_5 groups are rigid on the NMR time scale and equivalent. By raising the temperature the two *o*-F doublets and the two *m*-F multiplets coalesce (above 233 K *o*-F) to only one *o*-F doublet and one *m*-F multiplet resonance, most likely due to a fast rotation around its Pt–C bonds. The approximate calculated activation energy ($\Delta G^\ddagger_{233} \approx 45.9$ kJ/mol) is slightly lower than that observed in the Rh–Pt derivative **6** ($\Delta G^\ddagger_{258} \approx 55.3$ kJ/mol). The minor isomer **7b** shows two sets of static C_6F_5 resonances, confirming the inequivalence of the two C_6F_5 ligands bound to platinum (trans to $\mu\text{-Cl}$ and trans to $\mu\text{-PPh}_2\text{C}\equiv\text{CPh}$). The variable-temperature pattern observed for **7b** closely resembles that of derivatives **8–10** (see below). At low temperature the restricted rotation of the Pt–C bonds renders the two halves of each C_6F_5 group inequivalent. Upon warming, the four *o*-F and the four *m*-F signals broaden and coalesce (\approx between 273 and 283 K *o*-F, and 263–273 K *m*-F), while the two *p*-F signals remain unchanged. At the highest experimental temperature (323 K), however, neither of the two averaged *o*-F signals (one for each C_6F_5) merges from the base line.

The preparation of a series of hetero-bridged ($\mu\text{-Cl}$)-($\mu\text{-PPh}_2\text{C}\equiv\text{CPh}$) complexes was achieved by treatment of the starting bis[diphenyl(phenylethynyl)phosphine] **3–5** with [*cis*-Pt(C_6F_5)₂(THF)₂] (Scheme 3). The final cationic [($\text{PPh}_2\text{C}\equiv\text{CPh}$)Cp* $\text{M}(\mu\text{-Cl})(\mu\text{-}\kappa\text{P}:\eta^2\text{-PPh}_2\text{C}\equiv\text{CPh})\text{Pt}(\text{C}_6\text{F}_5)_2$](OTf) (M = Rh **8**, Ir **9**) and neutral [($\text{PPh}_2\text{C}\equiv\text{CPh}$)Cp* $\text{Ru}(\mu\text{-Cl})(\mu\text{-}\kappa\text{P}:\eta^2\text{-PPh}_2\text{C}\equiv\text{CPh})\text{Pt}(\text{C}_6\text{F}_5)_2$] **10** hetero-bridged complexes are isolated as

yellow solids in moderate (42% **10**) to good (75% **8**, 67% **9**) yields. The dimetallic formulation with a heteromixed ($\mu\text{-Cl}$)-($\mu\text{-PPh}_2\text{C}\equiv\text{CPh}$) bridging system is consistent with their analytical and spectroscopic data, and confirmed by an X-ray diffraction study on the Ru–Pt complex **10** (see below). The mass spectra (ES⁺) of cationic complexes exhibit the expected ion molecular fragment [($\text{PPh}_2\text{C}\equiv\text{CPh}$)Cp* $\text{M}(\mu\text{-Cl})(\mu\text{-}\kappa\text{P}:\eta^2\text{-PPh}_2\text{C}\equiv\text{CPh})\text{Pt}(\text{C}_6\text{F}_5)_2$]⁺ (*m/z* 1375 72% **8**, 1465 100% **9**), and their molar conductivities ($148 \Omega^{-1} \text{cm}^2 \text{mol}^{-1}$ **8**, $144 \Omega^{-1} \text{cm}^2 \text{mol}^{-1}$ **9**) in acetone solution are in the expected range for 1:1 electrolytes.¹³ Their IR spectra confirm the presence of bridging ($\nu(\text{C}\equiv\text{C})$ 1980 cm^{-1} **8**, 1981 cm^{-1} **9**, 1990 cm^{-1} **10**) and terminal ($\nu(\text{C}\equiv\text{C})$ 2172 cm^{-1} **8**, 2178 cm^{-1} **9**, 2169 cm^{-1} **10**) $\text{PPh}_2\text{C}\equiv\text{CPh}$ ligands, and additional information is inferred from the ^{31}P and ^{19}F NMR spectra (their solubility is low for ^{13}C NMR studies). Thus, two different phosphorus resonances (AX systems in **9** and **10**, and AMX (X = Rh) in **8**) are observed in the ^{31}P NMR spectra of these complexes, confirming the inequivalence of both phosphines. The low-field resonance (δ 36.7 **8**, 10.5 **9**, 59.9 **10**), which is strongly deshielded in relation to the corresponding precursor, is attributed to the bridging $\kappa\text{P}:\eta^2\text{-PPh}_2\text{C}\equiv\text{CPh}$, and the high field signal (δ 2.1 **8**, -31.7 **9**, 19.2 **10**), which appears close to those seen in the precursor, can be assigned to the terminal P-coordinated ligand. The $^2J_{\text{P-P}}$ coupling constants (51.5 Hz **8**, 26.1 Hz **9**, 41.6 Hz **10**) are typical for this type of complexes. The ^{19}F NMR spectra display two different sets of resonances, which are consistent with two chemically inequivalent C_6F_5 groups, one trans to Cl and the other one trans to the η^2 acetylenic entity. Furthermore, the presence of different ligands trans to the C_6F_5 rings induces different rotation energy barriers for the C_6F_5 groups. As a result of this situation, while the rigid pattern for one of the rings does not change over all the range of temperatures investigated, the set of signals for the other ring displays a marked dependence upon temperature. The variable-temperature spectra of **8** are shown in Figure 4. As can be seen, by increasing temperature, whereas the two *o*-F (-115.8 and -124.5 ppm) and two *m*-F (-163.5 and -164.1 ppm) signals corresponding to one of the C_6F_5 groups broaden, the resonances of the second set (δ *o*-F -116.6 , -121.8 ; 2-*m*-F -162.7) only give rise to sharper signals. The two *o*-F resonances coalesce at ca. 313 K, and from this equilibration the free energy of activation ΔG^\ddagger at the coalescence tem-

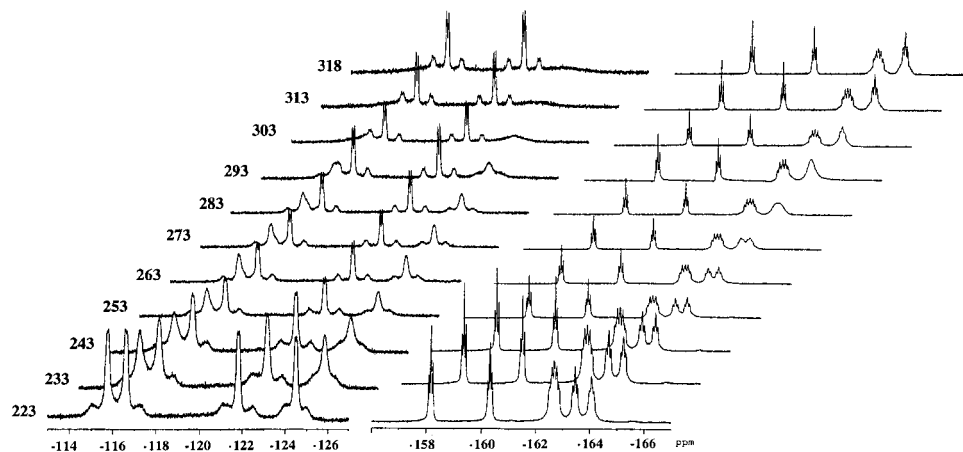

Figure 4. Variable-temperature ^{19}F NMR spectra of $[(\text{PPh}_2\text{C}\equiv\text{CPh})\text{Cp}^*\text{Rh}(\mu\text{-Cl})(\mu\text{-}\kappa\text{P}:\eta^2\text{-PPh}_2\text{C}\equiv\text{CPh})\text{Pt}(\text{C}_6\text{F}_5)_2](\text{OTf})$ **8** in CDCl_3 .

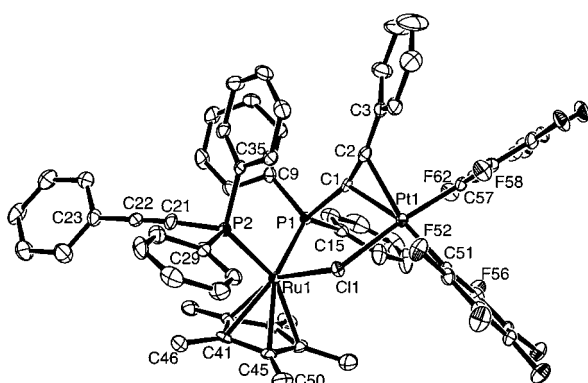

Figure 5. View of the molecular structure of complex $[(\text{PPh}_2\text{C}\equiv\text{CPh})\text{Cp}^*\text{Ru}(\mu\text{-Cl})(\mu\text{-}\kappa\text{P}:\eta^2\text{-PPh}_2\text{C}\equiv\text{CPh})\text{Pt}(\text{C}_6\text{F}_5)_2]$ **10**. Ellipsoids are drawn at the 50% probability level. Hydrogen atoms have been omitted for clarity.

perature for the rotation process has been calculated to be 54.25 kJ/mol. The m -F resonances coalesce to a multiplet above 283 K. Essentially similar patterns are observed for the Ir–Pt **9** and the Ru–Pt **10** compounds, for which the calculated activation energies for the restricted carbon–platinum bond rotation are $\Delta G^\ddagger_{313} \approx 54.29$ kJ/mol **9** and $\Delta G^\ddagger_{303} \approx 52.4$ kJ/mol **10**, respectively.

The structure proposed for these **7–10** binuclear complexes was confirmed by X-ray crystallography using a single crystal of **10**, obtained from slow diffusion of hexane into a solution of **10** in CH_2Cl_2 at -20°C (Figure 5 and Tables 2 and 5). This complex is a new member of the very small family of heterometallic Ru(II)–Pt(II) complexes, which have been previously reported.^{14,18} The structure clearly shows that the bis[diphenyl(phenylethynyl)phosphine] precursor complex **5** acts as a mixed Cl, η^2 -(alkyne) bidentate ligand toward the “ $cis\text{-Pt}(\text{C}_6\text{F}_5)_2$ ” fragment and reveals that the formation of **10** requires a significant reorientation of one phosphi-

Table 5. Selected Bond Lengths (Å) and Angles (deg) for $[(\text{PPh}_2\text{C}\equiv\text{CPh})\text{Cp}^*\text{Ru}(\mu\text{-Cl})(\mu\text{-}\kappa\text{P}:\eta^2\text{-PPh}_2\text{C}\equiv\text{CPh})\text{Pt}(\text{C}_6\text{F}_5)_2]$ **10**

Pt(1)–C(1)	2.229(3)	Pt(1)–C(2)	2.226(4)
Pt(1)–C(51)	2.026(4)	Pt(1)–C(57)	2.027(4)
Pt(1)–Cl(1)	2.3785(9)	Ru(1)–C(Cp*)	2.219(4)–2.258(3)
Ru(1)–P(1)	2.2912(10)	Ru(1)–P(2)	2.3124(9)
Ru(1)–Cl(1)	2.4358(10)	P(1)–C(1)	1.802(4)
C(1)–C(2)	1.224(5)	C(2)–C(3)	1.459(5)
P(2)–C(21)	1.773(4)	C(21)–C(22)	1.197(5)
C(22)–C(23)	1.443(5)	Ru(1)–Pt(1)	4.126
C(51)–Pt(1)–C(57)	85.62(14)	C(57)–Pt(1)–C(2)	85.66(14)
C(57)–Pt(1)–C(1)	104.83(14)	C(2)–Pt(1)–C(1)	31.90(12)
C(51)–Pt(1)–Cl(1)	86.86(10)	C(2)–Pt(1)–Cl(1)	100.98(10)
C(1)–Pt(1)–Cl(1)	82.96(10)	P(1)–Ru(1)–P(2)	92.55(3)
P(1)–Ru(1)–Cl(1)	87.60(3)	P(2)–Ru(1)–Cl(1)	91.87(3)
Pt(1)–Cl(1)–Ru(1)	117.95(4)	C(2)–C(1)–P(1)	162.3(3)
C(1)–C(2)–C(3)	166.3(4)	C(22)–C(21)–P(2)	175.3(3)
C(21)–C(22)–C(23)	179.5(4)		

noalkynyl ligand in the precursor. The ruthenium atom is pseudotetrahedral surrounded by one pentamethylcyclopentadienyl ligand, two phosphorus atoms of the two $\text{PPh}_2\text{C}\equiv\text{CPh}$ ligands, and the chlorine bridging atom. The platinum center of the “ $\text{Pt}(\text{C}_6\text{F}_5)_2$ ” unit completes its usual square-planar geometry with the alkyne entity of one $\text{P}(1)\text{Ph}_2\text{C}\equiv\text{CPh}$ ligand ($\text{C}(1)\equiv\text{C}(2)$), which is bonded in a $\mu\text{-}\kappa\text{P}:\eta^2$ bridging fashion. The Ru–C(Cp*) bond distances are similar to those seen in the precursor **5**, suggesting that the formation of the dimer has no influence on these distances. As expected, the two Ru–P distances are different, but curiously the Ru–P(1)(bridging) (2.2912(10) Å) distance is slightly shorter than the Ru–P(2)(terminal) (2.3124(9) Å) bond length, and both of them are slightly greater than those of **5**. Compared with the precursor, the Ru–Cl bridging distance is somewhat reduced (2.4358(10) Å in **10** vs 2.4649(9) Å in **5**). As we have previously found in related $[(\text{PET}_3)\text{Cp}^*\text{M}(\mu\text{-X})_2\text{Pt}(\text{C}_6\text{F}_5)_2]$ ($\text{M} = \text{Rh}, \text{Ir}; \text{X} = \text{Cl}, \text{C}\equiv\text{CR}$)^{16a,19} complexes, the “ $\text{Pt}(\text{C}_6\text{F}_5)_2$ ” unit is directed toward the same side as the Cp* ring, the Pt–Cl (2.3785(9) Å) and Pt–C(1,2)(acetylenic) (2.229(3), 2.226(4) Å) bond distances being comparable to those found in $[(\text{PPh}_2\text{C}\equiv\text{CPh})\text{ClPt}(\mu\text{-Cl})(\mu\text{-PPh}_2\text{C}\equiv\text{CPh})\text{Pt}(\text{C}_6\text{F}_5)_2]$ (Pt(1)–Cl(1) 2.380(4) Å; Pt(1)–C(13,14) 2.150(12), 2.200(12) Å).⁹ The coordination of the C(1)–C(2) acetyl-

(17) Verkade, J. G.; Quin, L. D., Eds. *^{31}P -NMR Spectroscopy in Stereochemical Analysis (Methods in Stereochemical Analysis, 8)*; VCH: New York, 1987; p 91.

(18) (a) Younus, M.; Long, N. J.; Raithby, P. R.; Lewis, J. J. *Organomet. Chem.* **1998**, *570*, 55. (b) Harriman, A.; Hissler, M.; Ziessel, R.; De Cian, A.; Fischer, J. *J. Chem. Soc., Dalton Trans.* **1995**, 4067. (c) Hissler, M.; Ziessel, R. *J. Chem. Soc., Dalton Trans.* **1995**, 893. (d) Sato, M.; Mugi, E. *J. Organomet. Chem.* **1996**, *508*, 159. (e) A search in the CSD (version 5.22) gives only 12 examples of Ru(II)–Pt(II) X-ray characterized binuclear complexes.

(19) Ara, I.; Berenguer, J. R.; Eguizabal, E.; Fornies, J.; Lalinde, E.; Martin, A.; Martinez, F. *Organometallics* **1998**, *17*, 4578.

enic fragment to Pt(1) causes the expected distortion from linearity effect (angles at C1 and C2 being 162.3° and 166.3°, respectively), but the C1C2 triple bond distance (1.224(5) Å) is similar to the uncoordinated C21C22 length (1.197(5) Å). The internal angles associated with the metal centers and the bridging chlorine atom (Cl(1)–Ru(1)–P(1) 87.60(3)°; Cl(1)–Pt(1)–C(1) 82.96(10)° acute and Ru(1)–Cl(1)–Pt(1) 117.95(4)° obtuse) are in accordance with the very long Ru...Pt distance (4.126 Å) found, which excludes any bonding metal interaction.

Conclusions

In summary, we have described the preparation and structures of several neutral [Cp**M*Cl₂(PPh₂C≡CPh)] (M = Rh **1**, Ir **2**), [Cp**Ru*Cl(PPh₂C≡CPh)]₂ **5**, and cationic [Cp**M*Cl(PPh₂C≡CPh)]₂(OTf) (M = Rh **3**, Ir **4**) diphenyl(phenylethynyl)phosphine complexes. ¹³C NMR studies suggest that the alkyne polarization upon alkyne complexation of PPh₂C≡CPh molecules strongly depends on the metal and the charge of the complex. Thus, while complexation of two PPh₂C≡CPh ligands to the neutral and low-valence "Cp**Ru*Cl" fragment seems to have no influence on the alkyne polarization, a notable polarization is observed for the analogous substituted high-valence cationic units "[Cp**M*Cl]⁺" [M = Rh, Ir(III)]. For the monophosphine neutral derivatives **1** and **2** alkyne polarization is less than in the cationic complexes **3** and **4**, but it is clearly enhanced with respect to that of free PPh₂C≡CPh. The interaction of these mononuclear complexes **1–5** with the labile solvento complex [*cis*-Pt(C₆F₅)₂(THF)₂] has been also studied. Several hetero-bridged (*μ*-Cl)(*μ*-κ²-PPh₂C≡CPh) heterobinuclear complexes **8–10** have been prepared by using the chloro-bis(phosphine) complexes as starting materials. Interestingly, while the dichloro-bridged Rh(II)–Pt(II) complex [(PPh₂C≡CPh)*Cp**Rh(*μ*-Cl)₂Pt(C₆F₅)₂] **6** was obtained starting from **1**, a final mixture of (*μ*-Cl)₂ **7a** and (*μ*-Cl)(*μ*-κ²-PPh₂C≡CPh) **7b** was obtained by using the iridium species [Cp**Ir*Cl₂(PPh₂C≡CPh)] **2** as the precursor, suggesting that the η² bonding capability of the PPh₂C≡CPh ligand is also susceptible to the nature of the metal center to which this ligand is P-bonded. The six d⁶–d⁸ species undergo fluxional behavior observable by ¹⁹F NMR spectroscopy, which is presumably related to the rotation around the Pt–*ipso*-C(pentafluorophenyl) bond. In the hetero-bridged complexes **8–10**, one of the C₆F₅ rings behaves as rigid and the dynamic behavior observed for the other ring is ascribed to the less sterically hindered C₆F₅ ring mutually *cis* to the *μ*-Cl bridging group. Furthermore, the rotation of this ring could be more easily achieved due to the fact that it is located *trans* to the η² acetylenic entity, which is known to have a higher *trans* influence than the chlorine atom.

Experimental Section

All manipulations were carried out under an argon atmosphere, and solvents (hexane, alkane mixture) were dried by standard procedures and distilled under dry N₂ before use. NMR spectra were recorded on a Bruker ARX-300 spectrometer, and the temperature of the routine NMR measurements was 293 K. Chemical shifts are reported in parts per million relative to external standards (SiMe₄, CFCl₃, and 85% H₃PO₄),

and all coupling constants are given in hertz. IR spectra were obtained on a Perkin-Elmer FT-IR Spectrum 1000 spectrometer using Nujol mulls between polyethylene sheets. Elemental analyses were carried out with a Perkin-Elmer 2400 CHNS/O microanalyzer. Mass spectra were recorded on an HP-5989B mass spectrometer using the ES(+) or ES(–) techniques. Conductivities were measured in acetone solutions (ca. 5 × 10^{−4} mol·L^{−1}) using a Crison GLP31 conductimeter. [*cis*-Pt(C₆F₅)₂(THF)₂],²⁰ [Cp**M*Cl(*μ*-Cl)]₂ (M = Rh, Ir),²¹ [Cp**Ru*Cl(*μ*-Cl)]₂,^{11a} and PPh₂C≡CPh²² were prepared by published methods.

Synthesis of [(η⁵-Cp*)RhCl₂(PPh₂C≡CPh)] (1). PPh₂C≡CPh (0.46 g, 1.62 mmol) was added to a suspension of [Cp**Rh*Cl(*μ*-Cl)]₂ (0.50 g, 0.81 mmol) in 30 mL of acetone, and the mixture was stirred for 5 min. The resulting red solution was evaporated to dryness and the residue treated with diethyl ether to yield **1** as an orange solid. Yield: 0.83 g (86%). Anal. Calcd for C₃₀Cl₂H₃₀PRh: C, 60.52; H, 5.08. Found: C, 60.94; H, 4.74. MS ES(+): *m/z* 559 [M – Cl]⁺ 100%; molecular peak not observed. IR (cm^{−1}): ν(C≡C) 2171(s); ν(Rh–Cl) 279(m), 270(sh). ¹H NMR (CDCl₃, δ): 8.14 (m, 4H), 7.64 (m, 2H), 7.44 (m, 3H), 7.37 (m, 6H) (Ph, PPh₂C≡CPh); 1.52 (d, ⁴J_{P–H} = 4.0, 15H, Cp*). ¹³C NMR (CDCl₃, δ): 133.9 (d, ²J_{C–P} = 11.0, *o*-C, PPh₂); 132.3 (d, ⁴J_{C–P} = 1.5, *o*-C, ≡CPh); 131.1 (d, ²J_{C–P} = 53.8, *ipso*-C, PPh₂); 130.8 (d, ⁴J_{C–P} = 2.8, *p*-C, PPh₂); 130.6 (s, *p*-C, ≡CPh); 129.0 (s, *m*-C, ≡CPh); 128.1 (d, ³J_{C–P} = 11.2, *m*-C, PPh₂); 121.1 (d, ³J_{C–P} = 3.2, *ipso*-C, ≡CPh); 109.4 (d, ²J_{C–P} = 11.9, C_β); 99.4 (dd, ¹J_{C–Rh} = 6.9, ²J_{C–P} = 3.1, C₅(CH₃)₅); 81.3 (d, ¹J_{C–P} = 90.5, C_α); 8.8 (d, ²J_{C–Rh} = 1.4, C₅(CH₃)₅). ³¹P NMR (CDCl₃, δ): 4.3 (d, ¹J_{P–Rh} = 147.8).

Synthesis of [(η⁵-Cp*)IrCl₂(PPh₂C≡CPh)] (2). A suspension of [Ir(η⁵-Cp*)Cl₂]₂ (0.2 g, 0.25 mmol) in acetone (20 mL) was treated with PPh₂C≡CPh (0.14 g, 0.50 mmol). After 5 min of stirring the resulting yellow solution was evaporated to dryness and the residue treated with diethyl ether to give **2** as a yellow solid. Yield: 0.29 g (85%). Anal. Calcd for C₃₀Cl₂H₃₀IrP: C, 52.63; H, 4.42. Found: C, 52.73; H, 4.44. MS ES(+): *m/z* 786 [M + C≡CPh]⁺ 11%; 649 [M – Cl]⁺ 100%; molecular peak not observed. IR (cm^{−1}): ν(C≡C) 2175(s); ν(Ir–Cl) 300(m), 271(m). ¹H NMR (CDCl₃, δ): 8.09 (m, 4H), 7.62 (m, 2H), 7.43 (m, 3H), 7.36 (m, 6H) (Ph, PPh₂C≡CPh); 1.54 (d, ⁴J_{P–H} = 2.6, 15H, Cp*). ¹³C NMR (CDCl₃, δ): 133.4 (d, ²J_{C–P} = 11.0, *o*-C, PPh₂); 131.9 (d, ⁴J_{C–P} = 1.6, *o*-C, ≡CPh); 130.9 (d, ²J_{C–P} = 63.0, *ipso*-C, PPh₂); 130.3 (d, ⁴J_{C–P} = 2.7, *p*-C, PPh₂); 130.1 (s, *p*-C, ≡CPh); 128.5 (s, *m*-C, ≡CPh); 127.5 (d, ³J_{C–P} = 5.9, *m*-C, PPh₂); 120.5 (d, ³J_{C–P} = 3.2, *ipso*-C, ≡CPh); 107.4 (d, ²J_{C–P} = 14.6, C_β); 92.4 (d, ²J_{C–P} = 2.9, C₅(CH₃)₅); 80.1 (d, ¹J_{C–P} = 104.2, C_α); 7.8 (d, ³J_{C–P} = 0.8, C₅(CH₃)₅). ³¹P NMR (CDCl₃, δ): −25.8 (s).

Synthesis of [(η⁵-Cp*)RhCl(PPh₂C≡CPh)]₂(OTf) (3). A light-protected solution of [(η⁵-Cp*)RhCl₂(PPh₂C≡CPh)] **1** (0.06 g, 0.10 mmol) in acetone (20 mL) was treated with Ag(CF₃SO₃) (0.026 g, 0.10 mmol) and the resulting mixture stirred at room temperature for 2 h. The solid AgCl formed was filtered through Celite and the filtrate treated with 0.03 g of PPh₂C≡CPh (0.10 mmol). After 5 min of stirring the solvent was removed in vacuo and the residue treated with diethyl ether. The resulting yellow solid was collected by filtration and then recrystallized from acetone/hexane. Yield: 0.06 g (63%). Anal. Calcd for C₅₁ClF₃H₄₅O₃P₂RhS: C, 61.55; H, 4.56; S, 3.22. Found: C, 61.30; H, 4.76; S, 3.03. Λ_M: 144 Ω^{−1}·cm²·mol^{−1}. MS ES(+): *m/z* 846 [M]⁺ 4%; 559 [M – PPh₂C≡CPh]⁺ 100%. IR (cm^{−1}): ν(C≡C) 2173(s); ν(CF₃SO₃[−]) 1275(s), 1224(w), 1149(m), 1032(m). ¹H NMR (CDCl₃, δ): 8.01 (m, 4H), 7.53 (m, 10H), 7.36 (m, 10H), 7.05 (t, J_{H–H} = 7.4, 2H), 6.91 (t, J_{H–H} = 7.4, 4H) (Ph, PPh₂C≡CPh); 1.43 (t, ⁴J_{P–H} = 4.0, 15H, Cp*). ¹³C

(20) Usón, R.; Forniés, J.; Tomás, M.; Menjón, B. *Organometallics* **1985**, *4*, 1912.

(21) Kang, J. W.; Moseley, K.; Maitlis, P. J. *J. Am. Chem. Soc.* **1969**, *91*, 5970.

(22) Carty, A. J.; Hota, N. K.; Ng, T. W.; Pate, H. A.; O'Connor, T. *J. Can. J. Chem.* **1971**, *49*, 2706.

NMR (CDCl_3 , δ): 132.7 ("t", $^2J_{C-P} + ^4J_{C-P} = 11.6$, *o*-C, PPh_2); 132.3 (*o*-C, PPh_2 and $\equiv\text{CPh}$); 131.9 (s, *p*-C, PPh_2); 131.6 (d, $^1J_{C-P} = 56.0$, *ipso*-C, PPh_2); 131.6 (s, *p*-C, PPh_2); 129.4 (s, *m*-C, $\equiv\text{CPh}$); 128.93 ("t", $^3J_{C-P} + ^5J_{C-P} = 11.9$, *m*-C, PPh_2); 128.89 ("t", $^3J_{C-P} + ^5J_{C-P} = 11.5$, *m*-C, PPh_2); 119.7 (s, *ipso*-C, $\equiv\text{CPh}$); 113.4 (t, $^2J_{C-P} + ^4J_{C-P} = 13.4$, C_β); 107.1 (dt, $^1J_{C-Rh} = 5.2$, $^2J_{C-P} = 2.3$, $\text{C}_5(\text{CH}_3)_5$); 77.9 (d, $^1J_{C-P} = 101.6$, C_α); 9.1 (s, $\text{C}_5(\text{CH}_3)_5$). ^{19}F NMR (CDCl_3 , δ): -78.56 (s, CF_3). ^{31}P NMR (CDCl_3 , δ): 2.3 (d, $^1J_{P-Rh} = 140.8$).

Synthesis of $[(\eta^5\text{-Cp}^*)\text{IrCl}(\text{PPh}_2\text{C}\equiv\text{CPh})_2](\text{OTf})$ (4). A solution of **2** (0.06 g, 0.09 mmol) in 20 mL of acetone was treated with $\text{Ag}(\text{CF}_3\text{SO}_3)$ (0.02 g, 0.09 mmol) and stirred in the absence of light for 3 h at room temperature. Filtration of the mixture through Celite and addition of $\text{PPh}_2\text{C}\equiv\text{CPh}$ (0.025 g, 0.088 mmol) gave a yellow solution, which was stirred for 30 min and then concentrated to ca. 5 mL in vacuo. The solution was treated with diethyl ether (20 mL) and stored for 2 h at -40°C to give **4** as a yellow microcrystalline solid, which was separated by filtration and washed with diethyl ether. Yield: 0.05 g (48%). Anal. Calcd for $\text{C}_{51}\text{ClF}_3\text{H}_{45}\text{O}_3\text{P}_2\text{IrS}$: C, 56.48; H, 4.18; S, 2.96. Found: C, 56.55; H, 4.45; S, 2.21. Λ_M : $150\ \Omega^{-1}\text{cm}^2\text{mol}^{-1}$. MS ES(+): m/z 935 $[\text{M}]^+$ 100%; 649 $[\text{M} - \text{PPh}_2\text{C}\equiv\text{CPh}]^+$ 24%; 599 $[\text{M} - \text{PPh}_2\text{C}\equiv\text{CPh} - \text{Cl} - \text{CH}_3]^+$ 45%. IR (cm^{-1}): $\nu(\text{C}\equiv\text{C})$ 2169(m); $\nu(\text{CF}_3\text{SO}_3^-)$ 1274(s), 1224(w), 1148(m), 1032(m). ^1H NMR (CDCl_3 , δ): 7.91 (m, 4H), 7.46 (m, 20H), 7.00 (m, 6H) (Ph, $\text{PPh}_2\text{C}\equiv\text{CPh}$); 1.44 (t, $^4J_{P-H} = 2.4$, 15H, Cp^*). ^{13}C NMR (CDCl_3 , δ): 32.7 ("t", $^2J_{C-P} + ^4J_{C-P} = 11.9$, *o*-C, PPh_2); 132.2 (*o*-C, PPh_2 and $\equiv\text{CPh}$); 131.8 (s, *p*-C, PPh_2); 131.2 (s, *p*-C, $\equiv\text{CPh}$); 131.1 (d, $^1J_{C-P} = 68.0$, *ipso*-C, PPh_2); 131.0 (s, *p*-C, PPh_2); 130.0 (d, $^1J_{C-P} = 64.0$, *ipso*-C, PPh_2); 129.1 (s, *m*-C, $\equiv\text{CPh}$); 128.7 ("t", $^3J_{C-P} + ^5J_{C-P} = 12.5$, *m*-C, PPh_2); 128.5 ("t", $^3J_{C-P} + ^5J_{C-P} = 12.2$, *m*-C, PPh_2); 119.6 (s, *ipso*-C, $\equiv\text{CPh}$); 111.5 (t, $^2J_{C-P} + ^4J_{C-P} = 16.1$, C_β); 101.7 (s, $\text{C}_5(\text{CH}_3)_5$); 77.8 (d, $^1J_{C-P} = 116.8$, C_α); 8.2 (s, $\text{C}_5(\text{CH}_3)_5$). ^{19}F NMR (CDCl_3 , δ): -78.55 (s, CF_3). ^{31}P NMR (CDCl_3 , δ): -32.3 (s).

Synthesis of $[(\eta^5\text{-Cp}^*)\text{RuCl}(\text{PPh}_2\text{C}\equiv\text{CPh})_2]$ (5). $\text{PPh}_2\text{C}\equiv\text{CPh}$ (0.19 g, 0.65 mmol) and Zn powder (0.5 g, 7.6 mmol) were added to a solution of $[\text{Cp}^*\text{RuCl}(\mu\text{-Cl})_2]$ (0.10 g, 0.16 mmol) in acetone (20 mL). The mixture was stirred for 1.5 h and then filtered through Celite. The resultant orange filtrate was concentrated to a small volume (2–3 mL) to give orange crystals of **5**, which were filtered and washed with cold acetone. Yield: 0.11 g (39%). (Analytical data of a microcrystalline sample crystallized from $\text{CHCl}_3/\text{hexane}$.) Anal. Calcd for $\text{C}_{50}\text{ClH}_{45}\text{P}_2\text{Ru}$: C, 63.89; H, 4.31. Found: C, 64.19; H, 4.00. MS ES(+): m/z 809 $[\text{M} - \text{Cl}]^+$ 3%; 769 $[\text{M} - \text{Ph}]^+$ 75%; 558 $[\text{M} - \text{PPh}_2\text{C}\equiv\text{CPh}]^+$ 32%; 523 $[\text{M} - \text{PPh}_2\text{C}\equiv\text{CPh} - \text{Cl}]^+$ 100%; molecular peak not observed. IR (cm^{-1}): $\nu(\text{C}\equiv\text{C})$ 2178(m); $\nu(\text{Ru}-\text{Cl})$ 294(w). ^1H NMR (CDCl_3 , δ): 8.07 (m, 4H), 7.58 (m, 4H), 7.48 (m, 4H), 7.34 (m, 2H), 7.28 (m, 4H), 7.23 (m, 6H), 6.81 (m, 6H) (Ph, $\text{PPh}_2\text{C}\equiv\text{CPh}$); 1.33 (s, 15H, Cp^*). ^{13}C NMR (CDCl_3 , δ): 139.3 ("t", $^1J_{C-P} + ^3J_{C-P} = 48.1$, *ipso*-C, PPh_2); 137.4 ("t", $^1J_{C-P} + ^3J_{C-P} = 42.3$, *ipso*-C, PPh_2); 132.8 ("t", $^2J_{C-P} + ^4J_{C-P} = 12.2$, *o*-C, PPh_2); 132.0 ("t", $^2J_{C-P} + ^4J_{C-P} = 11.0$, *o*-C, PPh_2); 131.8 (s, *o*-C, $\equiv\text{CPh}$); 129.1 (s, *p*-C, $\equiv\text{CPh}$); 129.0 (s, *p*-C, PPh_2); 128.5 (s, *m*-C, $\equiv\text{CPh}$); 128.2 (s, *p*-C, PPh_2); 127.6 ("t", $^3J_{C-P} + ^5J_{C-P} = 10.0$, *m*-C, PPh_2); 127.5 ("t", $^3J_{C-P} + ^5J_{C-P} = 9.6$, *m*-C, PPh_2); 122.8 (s, *ipso*-C, $\equiv\text{CPh}$); 106.9 ("t", $^2J_{C-P} + ^4J_{C-P} = 10.5$, C_β); 90.8 (t, $^2J_{C-P} = 4.2$, $\text{C}_5(\text{CH}_3)_5$); 85.8 (AXX' five-line pattern, $^1J_{C-P} + ^3J_{C-P} = 77.5$, C_α); 8.8 (s, $\text{C}_5(\text{CH}_3)_5$). ^{31}P NMR (CDCl_3 , δ): 20.1 (s).

Synthesis of $[(\text{PPh}_2\text{C}\equiv\text{CPh})\text{Cp}^*\text{Rh}(\eta\text{-Cl})_2\text{Pt}(\text{C}_6\text{F}_5)_2]$ (6). $[\text{cis-Pt}(\text{C}_6\text{F}_5)_2(\text{THF})_2]$ (0.12 g, 0.17 mmol) was added to a solution of $[(\eta^5\text{-Cp}^*)\text{RhCl}_2(\text{PPh}_2\text{C}\equiv\text{CPh})]$ **1** (0.10 g, 0.17 mmol) in CH_2Cl_2 (20 mL) and the mixture stirred for 20 min. The solvent was evaporated in vacuo, and the resulting orange residue was treated with diethyl ether, filtered, and washed with diethyl ether. Yield: 0.15 g (76%). Anal. Calcd for $\text{C}_{42}\text{-Cl}_2\text{F}_{10}\text{H}_{30}\text{P}_2\text{PtRh}$: C, 44.86; H, 2.69. Found: C, 44.60, H, 2.64. MS ES(+): m/z 1156 $[\text{Rh}_2\text{Cp}^*\text{Cl}_3(\text{PPh}_2\text{C}\equiv\text{CPh})_2]$ 11%, 559

$[\text{RhCp}^*\text{Cl}(\text{PPh}_2\text{C}\equiv\text{CPh})]^+$ 100%; molecular peak not observed. IR (cm^{-1}): $\nu(\text{C}\equiv\text{C})$ 2167(s); $\nu(\text{C}_6\text{F}_5)_X\text{-sens}$ 813(s), 800(s); $\nu(\text{Rh}-\text{Cl})_{\text{bridging}}$ 280(w), 267(w). ^1H NMR (CD_3COCD_3 , δ): 8.20 (m, 4H), 7.90 (d, $J_{H-H} = 8.0$, 2H), 7.66 (m, 7H), 7.55 (m, 2H) (Ph, $\text{PPh}_2\text{C}\equiv\text{CPh}$); 1.69 (d, $^4J_{P-H} = 4.0$, 15H, Cp^*). ^{13}C NMR ($\text{CD}_3\text{-COCD}_3$, δ): 155.0–135.0 (C_6F_5); 138.0 (d, $^2J_{C-P} = 11.6$, *o*-C, PPh_2); 137.3 (d, $^4J_{C-P} = 1.6$, *o*-C, $\text{C}\equiv\text{CPh}$); 136.6 (d, $^4J_{C-P} = 2.9$, *p*-C, PPh_2); 136.0 (s, *p*-C, $\equiv\text{CPh}$), 135.8 (d, $^2J_{C-P} = 57.6$, *ipso*-C, PPh_2); 134.0 (s, *m*-C, $\equiv\text{CPh}$); 133.8 (d, $^3J_{C-P} = 11.7$, *m*-C, PPh_2); 124.9 (d, $^3J_{C-P} = 3.2$, *ipso*-C, $\equiv\text{CPh}$); 116.7 (d, $^2J_{C-P} = 13.3$, C_β); 107.3 (dd, $^1J_{C-Rh} = 7.3$, $^2J_{C-P} = 2.6$, $\text{C}_5(\text{CH}_3)_5$); 83.3 (d, $^1J_{C-P} = 95.8$, C_α); 13.1 (d, $^2J_{C-Rh} = 1.2$, $\text{C}_5(\text{CH}_3)_5$). ^{19}F NMR (CD_3COCD_3 , δ): at 20°C , -118.00 (d, $^3J_{Pt-o-F} = 530$, 4-*o*-F); -165.30 (t, 2-*p*-F); -167.10 (m, 4-*m*-F). At -80°C , -117.86 , -117.91 (overlapping of two doublets, $^3J_{Pt-o-F} \approx 490$, 4-*o*-F); -163.60 (t, 2-*p*-F); -165.77 (m, 4-*m*-F). ^{31}P NMR ($\text{CD}_3\text{-COCD}_3$, δ): 7.2 (d, $^1J_{P-Rh} = 149.0$). Prolonged accumulation causes partial decomposition: some of the signals are attributed to the salt $[\text{Cp}^*\text{Rh}(\mu\text{-Cl})_3\text{RhCp}^*]_2[\text{Pt}(\text{C}_6\text{F}_5)_2(\mu\text{-Cl})_2](\delta_{\text{H}} 1.76$ (s). δ_{F} -117.5 , *o*-F; -166.7 , *p*-F; -167.7 , *m*-F), and a platinum phosphine species is also detected ($\delta_{\text{P}} -2.9$, $J_{Pt-P} = 2850$).

Reaction of $[(\eta^5\text{-Cp}^*)\text{IrCl}_2(\text{PPh}_2\text{C}\equiv\text{CPh})]$ (2) with $[\text{cis-Pt}(\text{C}_6\text{F}_5)_2(\text{THF})_2]$: Synthesis of $[(\text{PPh}_2\text{C}\equiv\text{CPh})(\eta^5\text{-Cp}^*)\text{-Ir}(\mu\text{-Cl})_2\text{Pt}(\text{C}_6\text{F}_5)_2]$ (7a) and $[\text{Cp}^*\text{ClIr}(\mu\text{-Cl})(\mu\text{-PPh}_2\text{C}\equiv\text{CPh})\text{Pt}(\text{C}_6\text{F}_5)_2]$ (7b). Starting from **2** (0.10 g, 0.15 mmol) and $[\text{cis-Pt}(\text{C}_6\text{F}_5)_2(\text{THF})_2]$ (0.01 g, 0.15 mmol), and following a procedure similar to that described for the synthesis of **6**, a yellow solid was obtained. This was identified by NMR spectroscopy as a mixture of **7a** and **7b** (2.5:1). All attempts to separate these products by repeated crystallizations were unsuccessful. Yield: 0.12 g (69%). Anal. Calcd for $\text{C}_{42}\text{Cl}_2\text{F}_{10}\text{H}_{30}\text{IrPt}$: C, 41.56; H, 2.49. Found: C, 41.59, H, 2.66. MS ES(+): m/z 649 $[\text{IrCp}^*\text{Cl}(\text{PPh}_2\text{C}\equiv\text{CPh})]^+$ 100%; molecular peak not observed. MS ES(-): m/z 1093 $[\text{Pt}_2(\text{C}_6\text{F}_5)_4\text{Cl}]^-$ 25%; 565 $[\text{Pt}(\text{C}_6\text{F}_5)_2\text{Cl}]^-$ 100%; 529 $[\text{Pt}(\text{C}_6\text{F}_5)_2]^-$ 15%; molecular peak not observed. IR (cm^{-1}): $\nu(\text{C}\equiv\text{C})$ 2171(vs) (**7a**), 1960(vs) (**7b**); $\nu(\text{C}_6\text{F}_5)_X\text{-sens}$ 810(s), 800(s); $\nu(\text{Ir}-\text{Cl})$ 312(w) (**7b**); 290(w), 268(w) (**7a**, **7b**). ^1H NMR (CD_3COCD_3 , δ) **7a**: 8.10 (m), 7.90 (d, $J = 6.8$), 7.65 (m), 7.56 (m) (Ph, $\text{PPh}_2\text{C}\equiv\text{CPh}$); 1.69 (d, $^4J_{P-H} = 2.4$, Cp^*). **7b**: 8.20–7.65 (overlapped with those of **7a**), 7.40, 7.26 (m, Ph, $\text{PPh}_2\text{C}\equiv\text{CPh}$); 1.52 (d, $^4J_{P-H} = 2.2$, Cp^*). ^{19}F NMR ($\text{CD}_3\text{-COCD}_3$, δ) at 20°C , **7a**: -118.10 (d, $^3J_{Pt-o-F} = 524$, *o*-F); -164.90 (t, *p*-F), -166.90 (m, *m*-F). **7b**: The *o*-F signals coalesce at this temperature; -161.75 (t, *p*-F); -163.07 (t, *p*-F); -164.92 (overlapped with *p*-F of **7a**, *m*-F); -166.83 (m, *m*-F). At -80°C , **7a**: -117.94 (d, *o*-F); -118.31 (d, *o*-F); -163.11 (t, *p*-F); -165.48 (t, *m*-F); -165.56 (t, *m*-F). **7b**: -116.50 (d, *o*-F); -117.35 (d, *o*-F); -119.18 (d, *o*-F); -120.78 (d, *o*-F); -159.86 (t, *p*-F); -161.49 (t, *p*-F); -163.11 (overlapped with *p*-F of **7a**, *m*-F); -163.72 (m, *m*-F); -163.94 (m, *m*-F); -164.46 (t, *m*-F). ^{31}P NMR (CD_3COCD_3 , δ): -12.4 (s) (**7a**); 19.7(s) (**7b**). The solid is not soluble enough for ^{13}C NMR study.

Synthesis of $[(\text{PPh}_2\text{C}\equiv\text{CPh})(\eta^5\text{-Cp}^*)\text{M}(\mu\text{-Cl})(\mu\text{-PPh}_2\text{C}\equiv\text{CPh})\text{Pt}(\text{C}_6\text{F}_5)_2](\text{CF}_3\text{SO}_3)$ (M = Rh **8, M = Ir **9**).** A general procedure is as follows: $[\text{cis-Pt}(\text{C}_6\text{F}_5)_2(\text{THF})_2]$ (0.03 g, 0.045 mmol) is added to a solution of $[(\eta^5\text{-Cp}^*)\text{MCl}(\text{PPh}_2\text{C}\equiv\text{CPh})_2](\text{CF}_3\text{-SO}_3)$ (M = Rh **3**, 0.045 g, 0.045 mmol; M = Ir **4**, 0.05 g, 0.045 mmol) in 20 mL of CH_2Cl_2 , and the mixture is stirred for 10 min. Evaporation of the mixture to dryness and treatment of the residue with cold Et_2O affords complexes **8** and **9** as orange and yellow solids, respectively.

Data for **8.** Yield: 0.05 g (75%). Anal. Calcd for $\text{C}_{63}\text{-ClF}_{13}\text{H}_{45}\text{O}_3\text{P}_2\text{PtRhS}$: C, 49.64; H, 2.98; S, 2.10. Found: C, 50.08, H, 3.17, S, 1.89. Λ_M : $148\ \Omega^{-1}\text{cm}^2\text{mol}^{-1}$. MS ES(+): m/z 1375 $[\text{M}]^+$ 72%; 1089 $[\text{M} - \text{PPh}_2\text{C}\equiv\text{CPh}]$ 100%. IR (cm^{-1}): $\nu(\text{C}\equiv\text{C})_{\text{terminal}}$ 2172(s); $\nu(\text{C}\equiv\text{C})_{\text{bridging}}$ 1980(m), $\nu(\text{CF}_3\text{SO}_3^-)$ 1266(m), 1224(w), 1154(m), 1032(m); $\nu(\text{C}_6\text{F}_5)_X\text{-sens}$ 808(m), 799(m). ^1H NMR (CDCl_3 , δ): 7.88 (m, 2H), 7.74 (m, 3H), 7.53 (m, 15H), 7.35 (m, 4H), 7.17 (m, 3H), 6.70 (m, 1H), 6.60 (m, 1H), 6.36 (m, 1H) (Ph, $\text{PPh}_2\text{C}\equiv\text{CPh}$); 1.39 (t, $^4J_{P-H} = 3.82$, 15H,

Cp*). ^{19}F NMR (CDCl_3 , δ) at 20 °C: -78.54 (s, 3F, CF_3); -116.40 (br, $^3J_{\text{Pt}-\text{o}-\text{F}} = 377$, 1-*o*-F); -117.34 (d, $^3J_{\text{Pt}-\text{o}-\text{F}} = 379$, 1-*o*-F); -121.33 (d, $^3J_{\text{Pt}-\text{o}-\text{F}} = 395$, 1-*o*-F); -123.70 (sbr, $^3J_{\text{Pt}-\text{o}-\text{F}} = 301$, 1-*o*-F); -158.70 (t, 1-*p*-F); -161.00 (t, 1-*p*-F); -163.33 (m, 2-*m*-F); -164.36 (m, 2-*m*-F). At -50 °C: -78.82 (s, 3F, CF_3), -115.8 (d, $^3J_{\text{Pt}-\text{o}-\text{F}} = 416$, 1-*o*-F); -116.6 (d, $^3J_{\text{Pt}-\text{o}-\text{F}} = 357$, 1-*o*-F); -121.8 (d, $^3J_{\text{Pt}-\text{o}-\text{F}} = 401$, 1-*o*-F); -124.5 (d, $^3J_{\text{Pt}-\text{o}-\text{F}} = 297$, 1-*o*-F); -158.2 (t, 1-*p*-F); -160.3 (t, 1-*p*-F); -162.7 (m, 2-*m*-F); -163.5 (m, 1-*m*-F); -164.1 (m, 1-*m*-F). ^{31}P NMR (CDCl_3 , δ): 36.7 (dd, $^2J_{\text{P}-\text{P}} = 51.5$, $^1J_{\text{P}-\text{Rh}} = 138.8$); 2.1 (dd, $^2J_{\text{P}-\text{P}} = 51.5$, $^1J_{\text{P}-\text{Rh}} = 143$). The complex is not soluble enough for ^{13}C NMR study.

Data for 9. Yield: 0.05 g (67%). Anal. Calcd for $\text{C}_{63}\text{ClF}_{13}\text{H}_{45}\text{IrO}_3\text{P}_2\text{PtS}$: C, 46.89; H, 2.81; S, 2.00. Found: C, 46.82; H, 3.06; S, 1.67. Λ_{M} : $144 \Omega^{-1}\text{cm}^2\text{mol}^{-1}$. MS ES(+): m/z 1465 $[\text{M}]^+$ 100%; 1178 $[\text{M} - \text{PPh}_2\text{C}\equiv\text{CPh}]$ 10%, 935 $[\text{M} - \text{Pt}(\text{C}_6\text{F}_5)_2]^+$ 49%. IR (cm^{-1}): $\nu(\text{C}\equiv\text{C})_{\text{terminal}}$ 2178(s); $\nu(\text{C}\equiv\text{C})_{\text{bridging}}$ 1981(m); $\nu(\text{CF}_3\text{SO}_3^-)$ 1264(s), 1224(w), 1154(s), 1032(s); $\nu(\text{C}_6\text{F}_5)_{\text{X-sens}}$ 807(m), 799(m); $\nu(\text{M}-\text{Cl})$ 279(w). ^1H NMR (CDCl_3 , δ): 7.81 (m, 5H), 7.50 (m, 17H), 7.34 (m, 1H), 7.17 (m, 2H), 6.67 (m, 4H), 6.35 (m, 1H) (Ph, $\text{PPh}_2\text{C}\equiv\text{CPh}$); 1.43 (s, 15H, Cp*). ^{19}F NMR (CDCl_3 , δ) at 20 °C: -78.51 (s, 3F, CF_3); -116.44 (d, $^3J_{\text{Pt}-\text{o}-\text{F}} \approx 360$, 1-*o*-F); -117.50 (d, $^3J_{\text{Pt}-\text{o}-\text{F}} = 380$, 1-*o*-F); -121.40 (d, $^3J_{\text{Pt}-\text{o}-\text{F}} = 400$, 1-*o*-F); -123.95 (s br, $^3J_{\text{Pt}-\text{o}-\text{F}} \approx 330$, 1-*o*-F); -158.36 (t, 1-*p*-F); -160.80 (t, 1-*p*-F); -163.10 (m, 2-*m*-F); -164.25 (s br, 2-*m*-F). At -50 °C: -78.77 (s, 3F, CF_3); -115.92 (d, $^3J_{\text{Pt}-\text{o}-\text{F}} = 365$, 1-*o*-F); -116.80 (d, $^3J_{\text{Pt}-\text{o}-\text{F}} = 365$, 1-*o*-F); -121.80 (d, $^3J_{\text{Pt}-\text{o}-\text{F}} = 382$, 1-*o*-F); -124.50 (d, $^3J_{\text{Pt}-\text{o}-\text{F}} = 299$, 1-*o*-F); -157.89 (t, 1-*p*-F); -160.10 (t, 1-*p*-F); -162.50 (t, 2-*m*-F); -163.30 (m, 1-*m*-F); -164.00 (m, 1-*m*-F). ^{31}P NMR (CDCl_3 , δ): 10.5 (d, $^2J_{\text{P}-\text{P}} = 26.1$); -31.7 (d, $^2J_{\text{P}-\text{P}} = 26.1$). The complex is not soluble enough for ^{13}C NMR.

Synthesis of $[(\text{PPh}_2\text{C}\equiv\text{CPh})(\eta^5\text{-Cp}^*)\text{Ru}(\mu\text{-Cl})(\mu\text{-PPh}_2\text{C}\equiv\text{CPh})\text{Pt}(\text{C}_6\text{F}_5)]$ 10. This complex was prepared, as a yellow solid, in the way described for **8** and **9**, starting from $[(\eta^5\text{-Cp}^*)\text{RuCl}(\text{PPh}_2\text{C}\equiv\text{CPh})_2]$ **5** (0.05 g, 0.06 mmol) and $[\text{cis-Pt}(\text{C}_6\text{F}_5)_2(\text{THF})_2]$ (0.04 g, 0.06 mmol). Yield: 0.035 g (42%). Anal. Calcd for $\text{C}_{62}\text{ClF}_{10}\text{H}_{45}\text{P}_2\text{PtRu}$: C, 54.21; H, 3.30. Found: C, 54.65; H, 3.05. MS ES(+): m/z 844 $[\text{M} - \text{Pt}(\text{C}_6\text{F}_5)_2]^+$ 6%; 753 $[\text{M} - (\text{C}_6\text{F}_5)_2 - (\text{PPh}_2\text{C}\equiv\text{CPh})]^+$ 22%; 721 $[\text{M} - (\text{C}_6\text{F}_5)_2 - (\text{PPh}_2\text{C}\equiv\text{CPh}) - \text{Cl} + 3\text{H}]^+$ 100%; 523 $[\text{RuCp}^*(\text{PPh}_2\text{C}\equiv\text{CPh})]^+$ 6%; molecular peak not observed. IR (cm^{-1}): $\nu(\text{C}\equiv\text{C})_{\text{terminal}}$ 2169(s); $\nu(\text{C}\equiv\text{C})_{\text{bridging}}$ 1990(s); $\nu(\text{C}_6\text{F}_5)_{\text{X-sens}}$ 807(m); 796(m). ^1H NMR (CDCl_3 , δ): 7.86 (m, 5H), 7.55 (m, 3H), 7.47 (m, 6H), 7.40 (m, 1H), 7.35 (m, 7H), 7.19 (d, 1H), 7.05 (t, 2H), 6.64 (t, 2H), 6.35 (m, 2H), 6.1 (t, 1H) (Ph, $\text{PPh}_2\text{C}\equiv\text{CPh}$); 1.25 (s, 15H, Cp*). ^{19}F NMR (CDCl_3 , δ) at 20 °C: ≈ -116.0 (s br, 1-*o*-F); -116.51 (d, $^3J_{\text{Pt}-\text{o}-\text{F}} = 394$, 1-*o*-F); -121.02 (d, $^3J_{\text{Pt}-\text{o}-\text{F}} = 416$, 1-*o*-F); ≈ -123.5 (s br, 1-*o*-F); -161.80 (t, 1-*p*-F); -163.40 (t, 1-*p*-F); -164.74 (m, 1-*m*-F); -165.44 (m, 1-*m*-F); -165.76 (m, 2-*m*-F). At -50 °C: -115.70 (d, $^3J_{\text{Pt}-\text{o}-\text{F}} = 357$, 1-*o*-F); -116.20 (d, $^3J_{\text{Pt}-\text{o}-\text{F}} = 386$, 1-*o*-F); -121.50 (d, $^3J_{\text{Pt}-\text{o}-\text{F}} = 386$, 1-*o*-F); -124.50 (d, $^3J_{\text{Pt}-\text{o}-\text{F}} = 268$, 1-*o*-F); -161.20 (t, 1-*p*-F); -162.60

(t, 1-*p*-F); -164.04 (m, 1-*m*-F); -164.50 (m, 1-*m*-F); -164.80 (m, 1-*m*-F); -165.50 (m, 1-*m*-F). ^{31}P NMR (CDCl_3 , δ): 59.9 (d, $^2J_{\text{P}-\text{P}} = 41.6$); 19.2 (d, $^2J_{\text{P}-\text{P}} = 41.6$). The complex is not soluble enough for ^{13}C NMR study.

X-ray Crystallography. Crystals of complexes **1**, **3**, **4**, **5**, and **10** were obtained by slow diffusion of hexane into a chloroform (**1**), acetone (**3** and **4**), or dichloromethane (**5** and **10**) solution of each compound. Table 2 reports details of the structural analyses for all complexes. For all the complexes, X-ray intensity data were collected with a NONIUS kCCD area-detector diffractometer, using graphite-monochromated Mo K α radiation. Images were processed using the DENZO and SCALEPACK suite of programs,²³ doing the absorption correction at this point, except for **1**, for which absorption correction was done using SORTAV.²⁴ The structures were solved by Patterson and Fourier methods using the DIRDIF92 program²⁵ and refined by full-matrix least squares on F^2 using the SHELXL-97 program.²⁶ All non-hydrogen atoms were assigned anisotropic displacement parameters, and all hydrogen atoms were constrained to idealized geometries fixing isotropic displacement parameters of 1.2 for the phenyl and 1.5 for the methyl groups times the U_{iso} value of their attached carbon. For **1**, the absolute structure parameter is 0.04(4). The crystals obtained for complexes **3**, **4**, and **10** did not contain lattice solvent; it was, however, found in **1** (two molecules of CHCl_3 with one of them disordered in two different positions) and **5** (1.55 CH_2Cl_2). A residual peak (1.002 e/A³) close to the Ir atom was observed for **4**, but with no chemical meaning.

Acknowledgment. We wish to thank the Dirección General de Investigación Científica y Técnica, Spain (Projects PB98-1595-C02-01, 02), and the Comunidad de La Rioja (APCI-200015 and a grant to M. Bernechea) for their support of this research.

Supporting Information Available: Further details of the structure determination of **1**·2 CHCl_3 , **3**, **4**, **5**·1.55 CH_2Cl_2 , and **10**, including atomic coordinates, bond distances and angles, and thermal parameters. Crystallographic data in CIF format. This material is available free of charge via the Internet at <http://pubs.acs.org>.

OM020052S

(23) Otwinowski, Z.; Minor, W. In *Methods in Enzymology*; Carter, C. W., Jr., Sweet, R. M., Eds.; Academic Press: New York, 1997; Vol. 276A, p 307.

(24) Blessing, R. H. *Acta Crystallogr.* **1995**, A51, 33.

(25) Beurskens, P. T.; Beurskens, G.; Bosman, W. P.; de Gelder, R.; Garcia-Granda, S.; Gould, R. O.; Smith, J. M. M.; Smykalla, C. *The DIRDIF92 program system*; Technical Report of the Crystallography Laboratory; University of Nijmegen: The Netherlands, 1992.

(26) Sheldrick, G. M. *SHELX-97, a program for the refinement of crystal structures*; University of Göttingen: Göttingen, Germany, 1997.