

# Chloride-Promoted Synthesis of Cis Bis-Chelated Palladium(II) Complexes from Ortho-Mercurated Tricarbonyl( $\eta^6$ -arene)chromium Complexes<sup>†</sup>

Alessandro Berger, Jean-Pierre Djukic,\* and Michel Pfeffer\*

Laboratoire de Synthèses Metallo-Induites, UMR 7513 CNRS, 4, rue Blaise Pascal, F-67070 Strasbourg Cedex, France

Jérôme Lacour and Laurent Vial

Département de Chimie Organique, Université de Genève, 30, quai Ernest Ansermet, CH-1211 Genève 4, Switzerland

André de Cian<sup>‡</sup> and Nathalie Kyritsakas-Gruber

Service Commun d'Analyse par Diffraction des Rayons X, UMR 7513 CNRS, 4, rue Blaise Pascal, F-67070 Strasbourg Cedex, France

Received June 4, 2003

A new method of synthesis of homo- and heteroleptic cis bis-chelated Pd(II) species by a transmetalation reaction of the ortho-mercurated 2-[tricarbonyl( $\eta^6$ -phenyl)chromium]pyridine with a series of bis(*u*-chloro) palladacyclic aromatic compounds in the presence of a large excess of the chloride salt [NMe<sub>4</sub>]Cl is reported. These (CO)<sub>3</sub>Cr-bound bis-chelated Pd(II) species can be designed for the preparation of enantiopure planar chiral cyclopalladated ( $\eta^6$ -arene)Cr(CO)<sub>3</sub> complexes. The study of the mechanism of this transmetalation reaction reveals the key role of the excess of chloride salt, which is necessary for the isolation of persistent heteroleptic bis-chelated Pd(II) complexes. This method was further applied to the synthesis of highly enantioenriched (+) and (–) samples of the ortho-chloropalladated 2-[tricarbonyl( $\eta^6$ -phenyl)chromium]pyridine, whose enantiopurity was assessed with the aid of diamagnetic  $\Lambda$  and  $\Delta$  TRISPHAT salts used as chiral shift <sup>1</sup>H NMR agents. The absolute configurations of the two enantioenriched complexes were obtained from the corresponding absolute structures determined by X-ray diffraction analyses. The molecular structures of six new heteroleptic bis-chelated Pd(II) complexes are reported.

## Introduction

There are no less than eight different procedures to synthesize metalated ( $\eta^6$ -arene)Cr(CO)<sub>3</sub> complexes available in the literature,<sup>1</sup> among which deprotonation–lithiation certainly represents the method most studied and applied since its discovery by Nesmeyanov in 1969.<sup>2</sup> A good illustration of the impact of such a deprotonation method applied to substituted ( $\eta^6$ -arene)Cr(CO)<sub>3</sub> complexes is given by the number of articles and monographs dedicated to this very topic, which represents more than 90% of all the published reports on metalated ( $\eta^6$ -arene)Cr(CO)<sub>3</sub> complexes.<sup>3</sup> Of course, this fact illustrates the efficiency of organolithium bases for deprotonating ( $\eta^6$ -arene)Cr(CO)<sub>3</sub> complexes, whatever their nature, e.g. carbanionic or amide-like.

One obvious limitation of this deprotonation method lies, however, in the high reactivity of the lithiated ( $\eta^6$ -arene)Cr(CO)<sub>3</sub> intermediates, which prevents their use at temperatures higher than –30 °C<sup>4</sup> and their storage in stock solutions over long periods of time.

One alternative method of direct metalation of ( $\eta^6$ -arene)Cr(CO)<sub>3</sub> complexes is the mercuration reaction by means of Hg(OAc)<sub>2</sub>, which affords compounds that are both temperature and air stable as well as reasonably reactive. Surprisingly, until recently, only three reports dealing with the matter were known.<sup>5</sup> The sparseness of data on such an important reaction applied to ( $\eta^6$ -arene)Cr(CO)<sub>3</sub> complexes was unusual,

\* To whom correspondence should be addressed. Fax: +33 (0)-390241526. Tel: +33 (0)390241523. E-mail: djukic@chimie.u-strasbg.fr (J.-P.D.), pfeffer@chimie.u-strasbg.fr (M.P.).

<sup>†</sup> This article is dedicated to Prof. Dr. Karl Heinz Dötz on his 60th birthday.

<sup>‡</sup> To whom requests pertaining to X-ray diffraction analyses should be addressed.

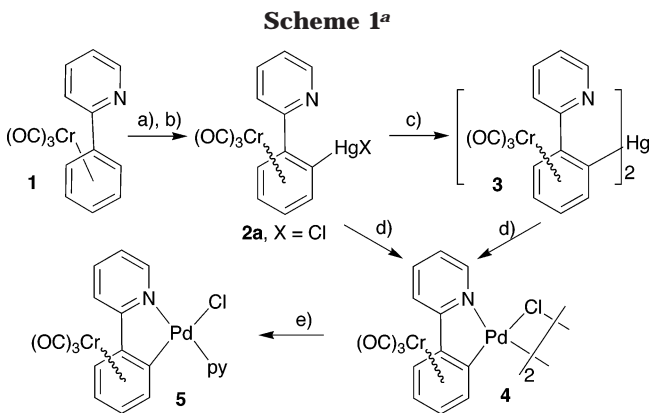
(1) Berger, A.; Djukic, J. P.; Michon, C. *Coord. Chem. Rev.* **2002**, *225*, 215.

(2) Nesmeyanov, A. N.; Kolobova, N. E.; Anisimov, K. N.; Markarov, Yu. V. *Izv. Akad. Nauk SSSR, Ser. Khim.* **1969**, 2665.

(3) (a) Semmelhack, M. F. In *Comprehensive Organometallic Chemistry II*; Abel, E. W., Stone, F. G. A., Wilkinson, G., Eds.; Pergamon Press: Oxford, U.K., 1995; Vol. 12, p 1017. (b) Rose-Munch, F.; Rose, E. *Curr. Org. Chem.* **1999**, *3*, 445. (c) Gibson, S. E.; Reddington, E. G. *Chem. Commun.* **2000**, 989.

(4) (a) Card, R. J.; Trahanovsky, W. S. *J. Org. Chem.* **1980**, *45*, 2555. (b) Semmelhack, M. F.; Ullenius, C. *J. Organomet. Chem.* **1982**, *235*, C10. (c) Sandilands, L. M.; Lock, C. J. L.; Faggiani, R.; Hao, N.; Sayer, B. G.; Quilliam, M. A.; McCarry, B. E.; McGlinchey, M. J. *J. Organomet. Chem.* **1982**, *224*, 267.

(5) (a) Magomedov, G. K. I.; Syrkin, V. G.; Frenkel, A. S. *Russ. J. Gen. Chem. (Engl. Transl.)* **1972**, *42*, 2450. (b) Magomedov, G. K. I.; Syrkin, V. G.; Frenkel, A. S.; Nekrassov, Yu. S.; Zábina, T. A. *Zh. Obshch. Khim.* **1975**, *45*, 2533. (c) Magomedov, G. K. I. *J. Organomet. Chem.* **1990**, *385*, 113.

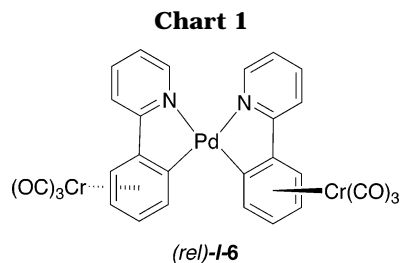


<sup>a</sup> Legend: (a) Hg(OAc)<sub>2</sub>, EtOH, 50 °C; (b) CaX<sub>2</sub>, EtOH; (c) [Me<sub>4</sub>N]Cl, acetone, room temperature; (d) Pd(MeCN)<sub>2</sub>Cl<sub>2</sub>, acetone -20 °C; (e) pyridine, room temperature.

especially if one considers the “popularity” of organomercury(II) chemistry in the recent past<sup>6</sup> and, of course, the amount of work published on the same topic for cymantrene, ferrocene, ruthenocene, and other metallocene derivatives.<sup>7</sup> Such a factual absence could be the consequence of at least two factors: (1) the persistent, although supported, belief that ( $\eta^6$ -arene)Cr(CO)<sub>3</sub> complexes react sluggishly or not at all with electrophiles, a class of reagents to which Hg(II) salts belong,<sup>8</sup> and (2) the established general toxicity of mercury salts,<sup>9</sup> which doubtless complicates possible large-scale developments.

In a previous report, it was demonstrated that various ( $\eta^6$ -arene)Cr(CO)<sub>3</sub> complexes that bear an endogenous ligand could be selectively ortho monomercurated to give the corresponding bimetallic products.<sup>10</sup> When they are treated with simple labile palladium(II) chloride derivatives, PdL<sub>2</sub>Cl<sub>2</sub>, these complexes exhibited exchange of the Hg(II) center for Pd(II), which provided an efficient route to ortho-palladated ( $\eta^6$ -arene)Cr(CO)<sub>3</sub> compounds (Scheme 1).

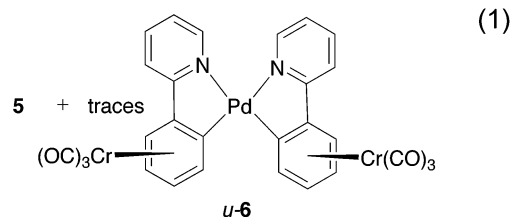
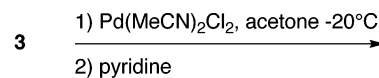
Use of mercurated arenes for the synthesis of palladated complexes can easily be justified<sup>11</sup> by the failure of all the direct palladation methods based on C–H bond activation, as tested with various ( $\eta^6$ -arene)Cr(CO)<sub>3</sub> complexes. In all cases, such attempts led to the irreversible decomposition of the Cr(0) substrate, under-



scoring that the electrochemical compatibility of the metal center that is to be attached to the Cr(0)-bound arene ligand is a relevant issue. In this article, we address an additional application of the transmetalation of mercurated ( $\eta^6$ -arene)Cr(CO)<sub>3</sub> complexes. We present a new method of synthesis of homo- and heteroleptic cis bis-chelated Pd(II)<sup>12</sup> species by an unusual reaction between an ortho-mercurated ( $\eta^6$ -arene)Cr(CO)<sub>3</sub> complex and a cyclopalladated aromatic compound. We show how these (CO)<sub>3</sub>Cr-bound bis-chelated Pd(II) species can be used for the preparation of enantiopure, planar chiral cyclopalladated ( $\eta^6$ -arene)Cr(CO)<sub>3</sub> complexes.

## Results and Discussion

**Formation of an “Odd Product”, the Homoleptic Trinuclear Bis-Chelated Pd(II) Complex *u*-6.**<sup>13</sup> In a previous report, we described the unexpected formation of minute amounts of crystalline *u*-6, a trinuclear (Pd,Cr,Cr) homoleptic cis bis-chelated Pd(II) complex, whose X-ray structure displays two Cr(CO)<sub>3</sub> moieties in a syn-facial relationship.<sup>10</sup> This compound was believed to be a secondary product of the transmetalation reaction of complex **3** with Pd(MeCN)<sub>2</sub>Cl<sub>2</sub>, which yielded **5** as the main product after pyridine quenching (eq 1). The



formation of *u*-6 was interpreted as the consequence of some homocoupling of **3** with the latter Pd(II) salt, a reaction that should have also yielded (*rel*)-I-6 (Chart 1). In fact, all our preliminary attempts at synthesizing this compound from a reaction between **2a** (or **3**) and **4** failed.

Later, we decided to investigate further the formation of such bis-chelated Pd(II) complexes, having in mind their possible use for the synthesis of enantioenriched,

(6) (a) Kobe, K. A.; Doumani, T. F. *Ind. Eng. Chem.* **1941**, *33*, 170. (b) McMahon, K. S.; Kobe, K. A. *Ind. Eng. Chem.* **1957**, *49*, 42.

(7) (a) Rausch, M.; Vogel, M.; Rosenberg, H. *J. Org. Chem.* **1957**, *22*, 900. (b) Rausch, M. D. *J. Org. Chem.* **1963**, *28*, 3337. (c) Rausch, M. D.; Genetti, R. A. *J. Org. Chem.* **1970**, *35*, 3888. (d) Slocum, D. W.; Jones, W. E.; Ernst, C. R. *J. Org. Chem.* **1972**, *37*, 4278. (e) Kovar, R. F.; Rausch, M. D. *J. Org. Chem.* **1973**, *38*, 1918. (f) Rolling, P. V.; Rausch, M. D. *J. Org. Chem.* **1974**, *39*, 1421. (g) Winter, C. H.; Han, Y. H.; Heeg, M. J. *Organometallics* **1992**, *11*, 3169. (h) Kur, S. A.; Heeg, M. J.; Winter, C. H. *Organometallics* **1994**, *13*, 1865. (i) Han, Y. H.; Heeg, M. J.; Winter, C. H. *Organometallics* **1994**, *13*, 3009. (j) Kur, S. A.; Winter, C. H. *J. Organomet. Chem.* **1996**, *512*, 39. (k) Wu, Y. J.; Cui, X. L.; Liu, Y. H.; Yuan, H. Z.; Mao, X. A. *J. Organomet. Chem.* **1997**, *543*, 63. (l) Mayor-Lopez, M. J.; Weber, J.; Mannfors, B.; Cunningham, A. F. *Organometallics* **1998**, *17*, 4983. (m) Wu, Y.; Huo, S.; Gong, J.; Cui, X.; Ding, L.; Ding, K.; Du, C.; Liu, Y.; Song, M. *J. Organomet. Chem.* **2001**, *637–639*, 27.

(8) Merlic, C. A.; Miller, M. M.; Hietbrink, B. N.; Houk, K. N. *J. Am. Chem. Soc.* **2001**, *123*, 4904.

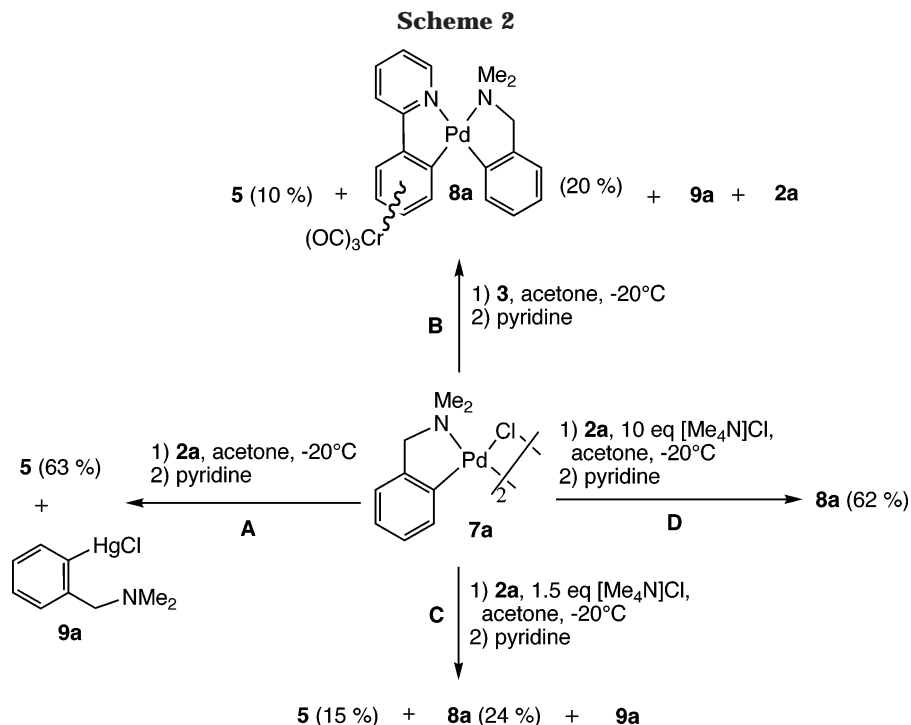
(9) Goldwater, L. J. In *Mercury, Mercurials and Mercaptans*; Miller, M. W., Clarkson, T. W., Eds.; Charles C. Thomas: Springfield, IL, 1973; p 56.

(10) Berger, A.; de Cian, A.; Djukic, J. P.; Fischer, J.; Pfeffer, M. *Organometallics* **2001**, *20*, 3230.

(11) Constable, E. C.; Leese, T. A. *J. Organomet. Chem.* **1987**, *335*, 293.

(12) Berger, A.; Djukic, J. P.; Pfeffer, M.; de Cian, A.; Kyritsakas-Gruber, N.; Lacour, J.; Vial, L. *Chem. Commun.* **2003**, 658.

(13) In the present paper, we use the *u* and *l* descriptors exclusively for the description of the relative configurations of planar chiral complexes and the associated “*rel*” prefix whenever we address racemates: (a) Seebach, D.; Prelog, V. *Angew. Chem., Int. Ed. Engl.* **1982**, *21*, 654; *Angew. Chem.* **1982**, *94*, 696. (b) Moss, G. P. *Pure Appl. Chem.* **1996**, *68*, 2193.



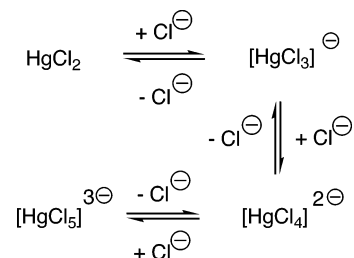
planar chiral metalated ( $\eta^6$ -arene)Cr(CO)<sub>3</sub> complexes, as detailed in this article.

We performed a series of test experiments aimed at understanding the conditions that would favor the formation of such a bis-chelated Pd(II) complex. As a model system we chose the reaction of the ortho-palladated *N,N*-dimethylbenzylamine species **7a**<sup>14</sup> with the ortho-chloromercurated 2-[tricarbonyl( $\eta^6$ -phenyl)-chromium]pyridine compound **2a** (Scheme 2; note that percentages correspond to yields of isolated compound).

A stoichiometric mixture (relative to the monomeric form of the Pd(II) substrate) of **2a** and **7a** reacted at low temperature to afford cleanly the cyclopalladated monomer **5** and ortho-chloromercurated *N,N*-dimethylbenzylamine species **9a**, upon quenching with pyridine (Scheme 2, path A). Similar experiments carried out with complexes **3** and **7a** afforded **5** and **2a** along with moderate amounts of the new bimetallic heteroleptic complex **8a** (Scheme 2, path B), thus revealing the importance of diarylmercury derivatives in the formation of the latter Pd(II) bis-chelate. Hence, we concentrated our efforts in finding an efficient way to favor the formation of **3** from **2a**, which was needed to increase significantly the proportions of Pd(II) bis-chelate **8a**.

Complex **3**, which consists of a mixture of (*rel*)-*l* and *u* stereoisomers, can be readily prepared from a reaction of **2a** with [Me<sub>4</sub>N]Cl in acetone. Vicente and co-workers have, until recently, extensively used this method of "symmetrization" that involves a halide as the promoter.<sup>15</sup> This important reaction was first addressed by Whitmore almost 80 years ago.<sup>16</sup> Although the mechanism of this reaction, which produces a diarylmercury(II) complex and HgCl<sub>2</sub>, has not yet been fully eluci-

### Scheme 3



dated, an excess of chloride helps in decreasing the reactivity of the Lewis acidic mercuric chloride that is released in the solution, thus preventing the backward reaction of R<sub>2</sub>Hg species with HgX<sub>2</sub>.<sup>15</sup> Mercuric chloride is therefore converted into a series of inert anionic adducts such as [HgX<sub>3</sub>]<sup>-</sup> (Scheme 3).<sup>17</sup> In concentrated solutions, the latter may also exist as the dianionic dimer [Hg<sub>2</sub>X<sub>6</sub>]<sup>2-</sup> and crystallize as such.<sup>17c</sup> Hence, we reacted **2a** with **7a** and 1.5 equiv of [Me<sub>4</sub>N]Cl, expecting the in situ formation of **3** and a significant overall increase of the proportions of **8a**. This was indeed observed, as depicted in Scheme 2 (path C). We noticed that complex **8a** could be obtained cleanly as the major product upon reacting **2a** and **7a** in the presence of 10 equiv of [Me<sub>4</sub>N]Cl (Scheme 2, path D). This result suggested a priori a 2-fold role of the excess of halide: (1) it promotes the steady formation of **3**, which converts readily into **8a** upon reaction with **7a**, and aids in keeping the concentration of **2a** at a low value and (2) it "neutralizes" the Lewis acid HgCl<sub>2</sub>, which prevents its reaction with **8a** to yield **4** and eventually **5** after

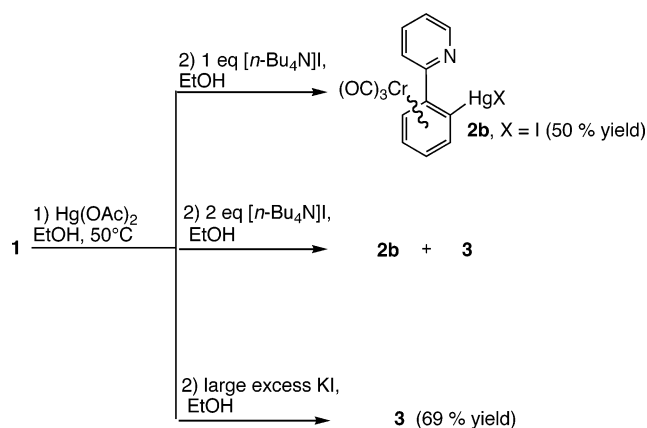
(14) Cope, A. C.; Friedrich, E. C. *J. Am. Chem. Soc.* **1968**, *90*, 909.

(15) (a) Vicente, J.; Abad, J. A.; Fernandez de Bobadilla, R.; Jones, P. G.; Ramirez de Arellano, M. C. *Organometallics* **1996**, *15*, 24. (b) Vicente, J.; Abad, J. A.; Rink, B.; Hernandez, F. S.; Ramirez de Arellano, M. C. *Organometallics* **1997**, *16*, 5269.

(16) Whitmore, F. C. *J. Am. Chem. Soc.* **1919**, *41*, 1841.

(17) (a) Mohana Rao, J. K.; Rajaram, R. K. *Z. Kristallogr.* **1982**, *160*, 219. (b) Goggin, P. L.; King, P.; McEwan, D. M.; Taylor, G. E.; Woodward, P.; Sandström, M. *J. Chem. Soc., Dalton Trans.* **1982**, 875. (c) Sikirica, M.; Grdenic, D.; Vickovic, I. *Cryst. Struct. Commun.* **1982**, *11*, 1299. (d) Clegg, W. *J. Chem. Soc., Dalton Trans.* **1982**, 593. Vezzosi, I. M.; Benedetti, A.; Albinati, A.; Ganazzoli, F.; Cariati, F.; Pellicari, L. *Inorg. Chim. Acta* **1984**, *90*, 1. (e) Terzis, A.; Mentzafos, D.; Tazmir-Riahi, H. A. *Inorg. Chim. Acta* **1985**, *101*, 77.

Scheme 4



pyridine quenching. We show below that the role of the halide in the overall transmetalation reaction leading to Pd(II) bis-chelates is central and multiple in its aspects.

**Role of the Halide in the So-Called “Symmetrization” Process.** The “symmetrization” of **2a** into **3** proceeded quantitatively when we subjected the former to the action of  $[\text{Me}_4\text{N}]\text{Cl}$  at  $-20^\circ\text{C}$  for 4 h. This result clearly demonstrates that the conversion of **2a** into **3** can readily take place at moderate subambient temperatures and likely occurs in the process leading to **8a**. It is well established that the nature of the halide greatly influences the efficiency of the “symmetrization”. Similarly to the above-mentioned early works of Whitmore on the symmetrization of  $\text{RHgX}$  compounds, we studied the effect of iodide, which is a far better promoter of this reaction than chloride.

The acetoxymercuration of **1** by  $\text{Hg}(\text{OAc})_2$  followed by treatment with a saturated solution of KI in EtOH yielded complex **3** as the sole product 30 min after the addition of halide. The isolation of the iodomercurated complex **2b** was possible only if  $\text{nBu}_4\text{NI}$  was used in stoichiometric amounts. The addition of 1 equiv of the latter salt to the solution resulting from the acetoxymercuration of **1**, at room temperature after 30 min of stirring, afforded complex **2b** in 50% yield. The same experiment carried out with 2 equiv of  $\text{nBu}_4\text{NI}$  yielded, after 30 min of reaction, a mixture containing **3** and **2b** (Scheme 4). It is worth noting that the treatment of the chloromercuric compound **2a** with 4 equiv of KI at  $60^\circ\text{C}$  for 24 h yielded complex **3** quantitatively.

As a rationale to the symmetrization reaction mechanism, it has been frequently postulated that  $\text{RHgX}$  species are inherently in equilibrium with  $\text{R}_2\text{Hg}$  and  $\text{HgX}_2$  in solution (eq 2).<sup>18</sup> Hence, the addition of the



Lewis base “**B**”, neutral or anionic in character, would help to shift the equilibrium to the right as a result of the formation of the corresponding stable  $\text{HgX}_2 \cdot \text{B}$  adduct. Indeed, the symmetrizations of halogenomercurated alkyls or aryls can also be promoted by bases<sup>19</sup> or chelating ligands<sup>20</sup> as well as by halides, as previously mentioned.

In the case of the symmetrization of chloro-/iodomercurated ( $\eta^6$ -arene) $\text{Cr}(\text{CO})_3$  substrates addressed here, an alternative mechanism can be proposed that takes into

Scheme 5

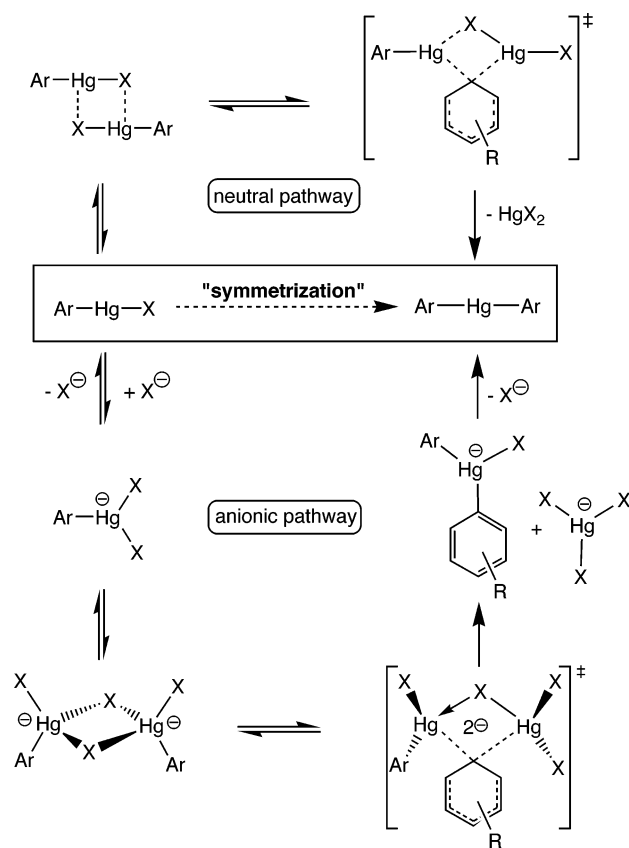
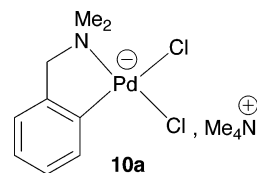


Chart 2



consideration the large amount of  $\text{X}^-$  present in the reaction medium (Scheme 5) and the known electron-withdrawing effect of the  $\text{Cr}(\text{CO})_3$  moiety. This proposal implies a nucleophilic attack of the halide at the particularly electrophilic  $\text{Hg}(\text{II})$  center of  $\text{RHgX}$  to give the putative anionic mercurate intermediate  $[\text{RHgX}_2]^-$ ,<sup>21</sup> which might dimerize to give the bridged transient species  $[\text{RHgX}_2]_2^{2-}$ ; this species subsequently would undergo an intramolecular transposition of the aryl group and would yield the diarylmercury(II) product and the inert  $[\text{HgX}_3]^-$  anion.<sup>17</sup>

**Role of  $\text{Cl}^-$  in the Transmetalation Process.** It must be noted that, in the course of the transmetalation reaction leading to heteroleptic complex **8a**, the chloride can also interact with the cyclopalladated substrate **7a** to yield the palladate **10a** (Chart 2).

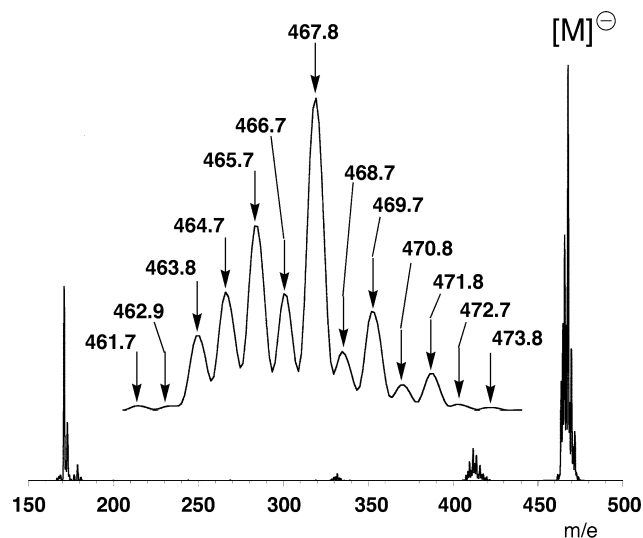
A few examples of chloro-bridged cyclopalladated aromatics have been shown to behave as Lewis acids

(18) (a) Whitmore, F. C.; Sobatzki, R. J. *J. Am. Chem. Soc.* **1933**, *55*, 1128. (b) Dessy, R. E.; Lee, Y. K.; Kim, J.-Y. *J. Am. Chem. Soc.* **1961**, *113*, 1163. (c) Reynolds, G. F.; Daniel, S. R. *Inorg. Chem.* **1967**, *6*, 480.

(19) (a) Whitmore, F. C.; Hanson, E. R.; Carnahan, F. L. *J. Am. Chem. Soc.* **1929**, *51*, 894. (b) Jensen, F. R.; Rickborn, B. *J. Am. Chem. Soc.* **1964**, *86*, 3784.

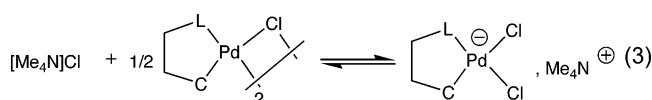
(20) Halpern, Y.; Garti, N. *J. Organomet. Chem.* **1975**, *92*, 291.

(21) Ibrahim, S. E.; Kreevoy, M. M. *J. Phys. Chem.* **1977**, *81*, 2143.

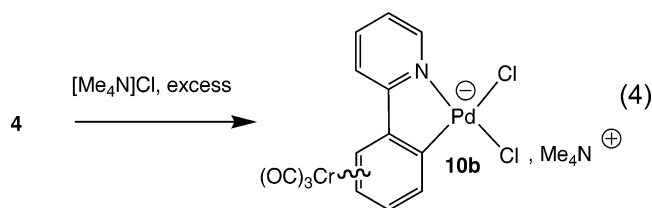


**Figure 1.** Negative mode electrospray mass spectrum of a solution of **10b** in acetone. The inset displays an enlargement of the parent peak of the anion with its associated isotopic distribution.

toward halides to give dihalogenopalladates such as **10a**.<sup>22</sup> In a medium where the concentration of chloride is high, the formation of palladates must be considered (eq 3).



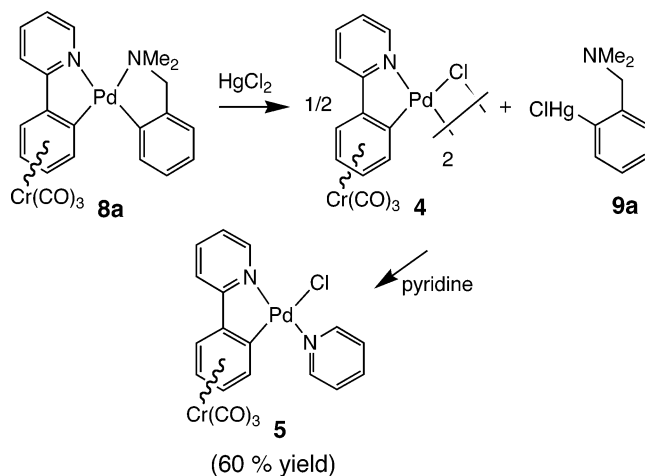
We were able to prepare a very stable sample of **10b** from the reaction of **4** with  $[\text{Me}_4\text{N}]\text{Cl}$  in acetone (eq 4).



This organometallic salt was successfully characterized by electrospray mass spectroscopy (ESMS) in the negative mode. Figure 1 shows the ESMS spectrum obtained after the injection of a solution of **10b** in acetone in the spectrometer. A large complex peak centered at 468 Da corresponding to the organometallic anion of **10b** as well as a smaller one at around 332 Da corresponding to a  $\text{Cr}(\text{CO})_3$ -free anion could be observed; the inset displays an enlargement of the anion's parent peak and the isotopic distribution around the main signal at 468 Da. The peak distribution fits almost ideally the theoretical one calculated for  $\text{C}_{14}\text{H}_6\text{NO}_3\text{Cl}_2\text{CrPd}$ , the anionic part of **10b**.

Complex **10b**, which proved to be stable in solution in acetone, presented spectroscopic features different from those related to other analogous heterodinuclear complexes such as **5**. The IR spectrum measured in  $\text{CH}_2\text{Cl}_2$  particularly illustrates the influence of the negative charge on the  $d-\pi^*$  back-bonding from the Cr center to its carbonyl ligands. The two  $A_1$  and E

## Scheme 6



stretching bands of the  $\text{Cr}(\text{CO})_3$  group in **10b** (1954 and  $1877\text{ cm}^{-1}$ ) are shifted toward lower wavenumbers by values of about 6 and  $12\text{ cm}^{-1}$ , respectively, as compared to the corresponding bands of neutral complex **5** (1960 and  $1889\text{ cm}^{-1}$ ), and by values of about  $15\text{ cm}^{-1}$  as compared to the averaged spectrum of a mixture of the dimeric diastereomers **4** (1968 and  $1893\text{ cm}^{-1}$ ). This effect can be consistently interpreted in terms of an increased flow of electron density in **10b** from the Pd center toward the Cr atom.<sup>23</sup>

Treating **10b** with an excess of pyridine in acetone quantitatively yielded **5**. A treatment of the same anion by  $\text{HgCl}_2$  in excess was carried out in order to check the possibility of forming **2a**, which would indicate that palladates play a role in the transmetalation reaction. This hypothesis was ruled out, since the only product recovered was **4**. Nonetheless, we cannot exclude that palladates are the major Pd(II) species in the early steps of the transmetalation reaction.

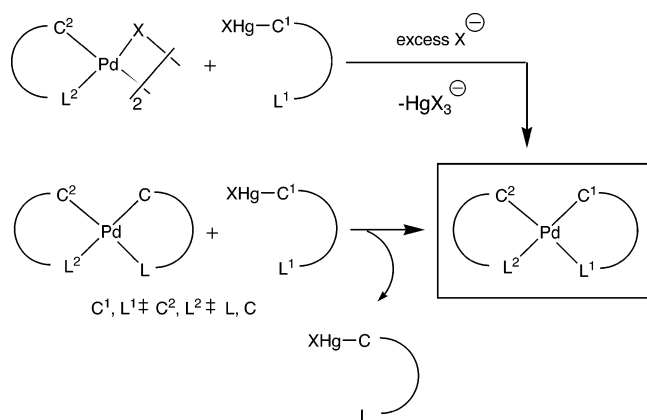
We noted that  $\text{HgCl}_2$  was capable of attacking the electron-rich Pd(II) center of **8a**. The treatment of a pure sample of the latter with 1 equiv of  $\text{HgCl}_2$  over 6 h afforded, upon subsequent treatment with pyridine, minute amounts of **2a** and compounds **9a** and **5** as the major products. The latter was recovered in 60% yield (Scheme 6). The outcome of this reaction can easily be interpreted by a difference in reactivity of the two  $\text{C}_{\text{Ar}}-\text{Pd}$  bonds of **8a**. Given the established deactivating effect of  $\text{Cr}(\text{CO})_3$ , the mercury center is more inclined to bind and react with the "electron-rich" chelating ligand: i.e., the benzylamine fragment. The slight amounts of **2a** recovered from the reaction mixture may indicate that only a small fraction of **8a** underwent the cleavage of the  $\text{C}-\text{Pd}$  bond related to the Cr-bound arene. This result is reminiscent of those published several years ago by van Koten and co-workers,<sup>24</sup> who addressed the reactivity of related heteroleptic bis-chelates of Pd(II) and Pt(II) toward  $\text{Hg}(\text{OAc})_2$ . The authors demonstrated that the site of the electrophilic attack was essentially determined by electronic factors, the electrophilic attack of the Hg(II) salt being directed at the carbon-metal bond and the metal center of the Pd(II) and Pt(II)

(23) (a) Bitterwolf, W. E. *Polyhedron* **1988**, *7*, 1377. (b) Neuse, E. W. *J. Organomet. Chem.* **1975**, *99*, 287.

(24) van der Ploeg, A. F. M. J.; van Koten, G.; Vrieze, K. *J. Organomet. Chem.* **1981**, *222*, 155.

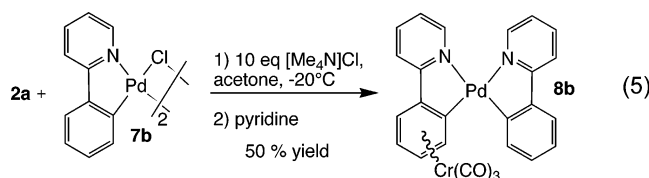
(22) Dehand, J.; Fischer, J.; Pfeffer, M.; Mitschler, A.; Zinsius, M. *Inorg. Chem.* **1976**, *15*, 2675.

Scheme 7



substrates, respectively. Hence, in the reaction of **2a** with **7a**, the excess of halide did not only promote the formation of **3** but also contribute in “preserving” the heteroleptic Pd(II) complex **8a** from a subsequent reaction with  $HgCl_2$ .

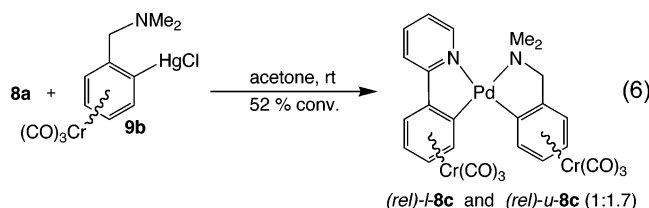
The experimental conditions previously optimized for the formation of **8a** proved to be also appropriate for the synthesis of **8b** (eq 5). Complex **8b** was synthesized



in 50% isolated yield by reacting stoichiometric amounts of **2a** and **7b** in the presence of a large excess of  $[Me_4N]Cl$  in acetone at  $-20^\circ C$ .

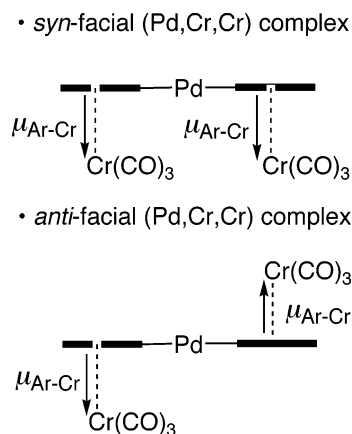
**Syntheses of  $Cr(CO)_3$ -Bound Homo- and Heteroleptic Pd(II) Complexes.** Given the importance of the deactivation of the  $Pd-C_{Ar}$  bond by the electron-withdrawing effects of the Cr-bound chelating unit and the relative sensitivity of these bis-chelates toward electrophiles such as  $HgCl_2$ , we decided to check whether compounds such as **8a** could serve as substrates for the synthesis of other Pd(II) bis-chelates. The reaction would consist of a ligand-exchange step and the replacement of the “electron-rich” benzylamine fragment by a more electron-withdrawing chelating unit. In other terms, the driving force of the reaction would be the formation of a Pd(II) bis-chelate, stabilized by the combined electron-withdrawing effects of the two chelating units (Scheme 7).

Tri-nuclear complexes **8c** were synthesized by reacting **8a** with **9b** in acetone at room temperature (eq 6).

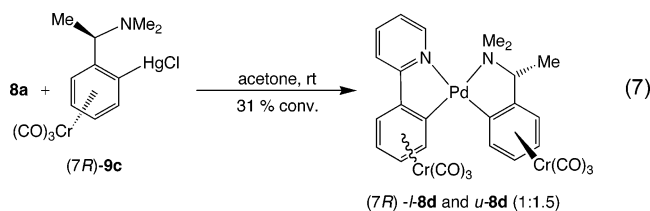


The overall conversion after purification was 52%, and the ratio between diastereomers (*rel*-*l*-**8c** and *rel*-*u*-**8c**) was evaluated to be approximately 1:1.7, respectively. In fact, this predominance of (*rel*-*u*-**8c**) is only

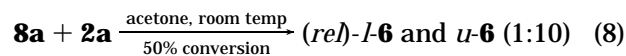
Scheme 8



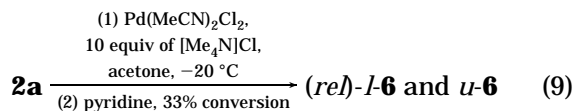
indicative of its relative overall stability as compared to that of (*rel*-*l*-**8c**). We observed, indeed, that the latter decomposed more rapidly in solution than its related stereoisomer *u*-**8c**. Similarly, complexes **8d** were obtained by a stoichiometric reaction of **8a** with (*7R*)-**9c**. The two diastereomers (*7R*)-*l*-**8d** and (*7R*)-*u*-**8d** were recovered with 31% conversion as a mixture containing a majority of (*7R*)-*u*-**8d** (1:1.5 ratio) (eq 7). Complexes **6**



were synthesized (isolated) by a reaction of **8a** with **2a** in acetone at room temperature with 50% conversion (eq 8).



In this experiment we also observed a marked air sensitivity of diastereomer (*rel*-*l*-**6**), illustrated by a (*rel*-*l*-**6** to *u*-**6**) ratio of 1:10. In fact, complexes **6** could be generated from a one-pot reaction of **2a** with  $Pd(MeCN)_2Cl_2$  in the presence of a large excess of  $Cl^-$  with 33% conversion after chromatographic separation. In this case the (*rel*-*l*-**6**:*u*-**6**) ratio was 1:5 (eq 9).

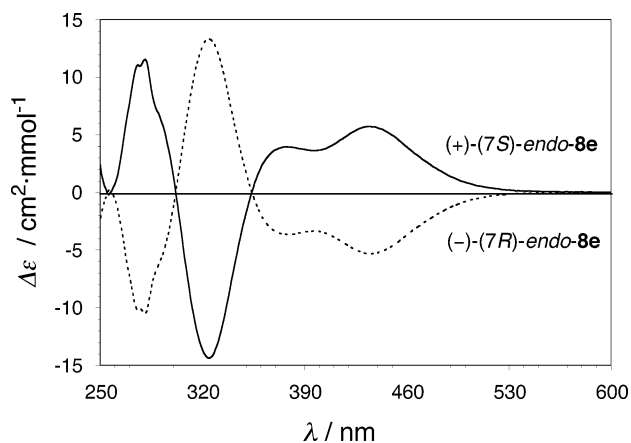
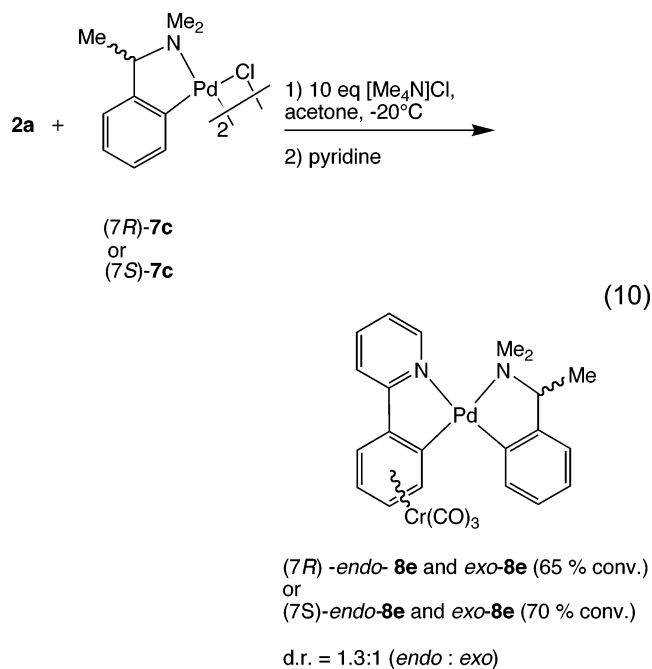


Interestingly, the *syn*-facial compounds could be readily separated from their *anti*-facial related isomers by classical low-temperature chromatography on silica gel, due to their predictable difference of polarity. The coordination of an arene ligand to a  $Cr(CO)_3$  moiety creates the dipolar moment component  $\mu_{Ar-Cr}$  along the  $C_3$  axis of the facial  $Cr(CO)_3$  group, which is oriented from the arene's centroid toward the Cr atom.<sup>25</sup> It is therefore clear that the heterotrimetallic (Pd,Cr,Cr) *syn*-facial complexes will possess a molecular dipolar moment higher than that of the *anti*-facial isomers. Ignoring the in-plane dipolar moment component of the bis-chelate, the two components  $\mu_{Ar-Cr}$  in *syn*-facial com-

pounds such as *u*-**6** and *u*-**8c,d** are roughly parallel, while in anti-facial isomers they are anti-parallel (Scheme 8). Consistently, in all three cases silica gel column chromatography delivered the anti-facial trinuclear isomers, i.e., (*rel*)-**16**, (*rel*)-**18c**, and **18d**, before the syn-facial isomers (see Experimental Section).

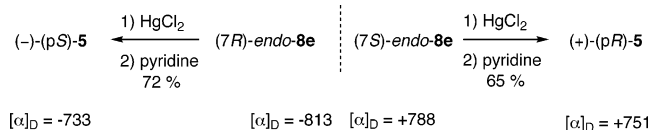
**Synthesis of Planar Chiral Enantioenriched Palladated ( $\eta^6$ -arene)Cr(CO)<sub>3</sub> Complexes from the Chloromercurated 2-[Tricarbonyl( $\eta^6$ -phenyl)chromium]pyridine.** We decided to turn the drawback of the reactivity of bis-chelated Pd(II) complexes toward HgCl<sub>2</sub> into an advantage for the synthesis of enantioenriched, planar chiral cyclopalladated ( $\eta^6$ -arene)Cr(CO)<sub>3</sub> complexes, which could be of interest in various applications of homogeneous catalysis.<sup>26</sup> In view of the above-mentioned results, it seemed technically feasible to introduce chiral information in the transmetalation step by using, as a chiral auxiliary, one of the readily available enantioenriched *7R* or *7S* cyclopalladated dimers of  $\alpha$ -methyl-*N,N*-dimethylbenzylamine.<sup>27</sup> The transmetalation reaction could therefore lead to couples of enantioenriched diastereomers, which could be physically separated and submitted to HgCl<sub>2</sub> in order to initiate the release of the enantioenriched cyclopalladated ( $\eta^6$ -arene)Cr(CO)<sub>3</sub> complex. If such a method based on the use of heteroleptic Pd(II) complexes could be applied more generally to other potent planar chiral Pd(II) compounds, it would provide a convenient route to valuable organometallic complexes.

The reaction of complex **2a** with either (*7R*)-**7c** or (*7S*)-**7c** in the presence of 10 equiv of [Me<sub>4</sub>N]Cl afforded the corresponding pairs of diastereomers: i.e., (*7R*)-*endo*-**8e**/*(7R)*-*exo*-**8e** and (*7S*)-*endo*-**8e**/*(7S)*-*exo*-**8e** in 65 and 70% yields, respectively (eq 10). In both cases the *endo*:*exo*



**Figure 2.** Dichrograms of 0.13 mM solutions of (+)-(*7S*)-*endo*-**8e** and (-)-(*7R*)-*endo*-**8e** in methanol at 20 °C.

### Scheme 9



ratio was found to be 1.3:1. All stereoisomers of **8e** could be readily characterized by X-ray diffraction analysis. This task was made easier by the fact that each *endo*/*exo* pair of compounds happened to cocrystallize in a pseudo-centrosymmetric space group (vide infra). Fortunately, we succeeded in physically separating the *endo* and *exo* diastereomers by chromatography on silica gel.

Optimal separations were performed at +5 °C with dry chloroform as the eluent. The *exo* isomers, more polar in nature, were more difficult to purify and separate from pollutants, consisting essentially of organic substances and 2-[( $\eta^6$ -phenyl)Cr(CO)<sub>3</sub>]pyridine. We therefore concentrated our efforts on obtaining analytically pure samples of (*7R*)- and (*7S*)-*endo*-**8e**, which were cleanly released in the first eluted colored chromatographic band. Their stereochemical relationship of enantiomers was confirmed readily by the determination of their specific rotation, [ $\alpha$ ]<sub>D</sub>, at 20 °C and by the measurement of their optical absorption circular dichroism. Figure 2 displays the dichrograms of (*7R*)- and (*7S*)-*endo*-**8e**, whose Cotton effects are reciprocal.

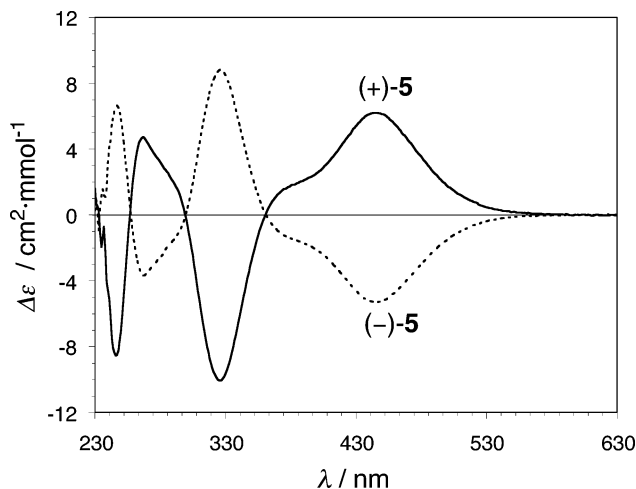
**“Release” of Compounds (+)-**5** and (-)-**5** and Determination of Their Enantiopurity and Absolute Planar Configuration.** Enantioenriched samples of **5** were efficiently obtained by the mild reaction of both (*7R*)- and (*7S*)-*endo*-**8e** with stoichiometric amounts of HgCl<sub>2</sub> over 14 h followed by a treatment with dry pyridine (Scheme 9). The optical activity of each sample of enantioenriched **5** was assessed by classical polarimetry as well as by circular dichroism spectropolarimetry (Figure 3). The enantiomeric purities of compounds (-)-**5** and (+)-**5** were then determined using [*n*-Bu<sub>3</sub>NH]-[ $\Delta$ -TRISPHAT] and [*n*-Bu<sub>4</sub>N][ $\Delta$ -TRISPHAT] salts<sup>28</sup> as diamagnetic NMR chiral shift agents.<sup>29</sup> The intrinsic precision of this <sup>1</sup>H NMR based technique is limited by an error of  $\pm 1.0\%$  on the value of the ee, which was established by a comparison with the values obtained

(25) Solladié-Cavallo, A. *Tetrahedron* **1985**, *4*, 901 and references therein.

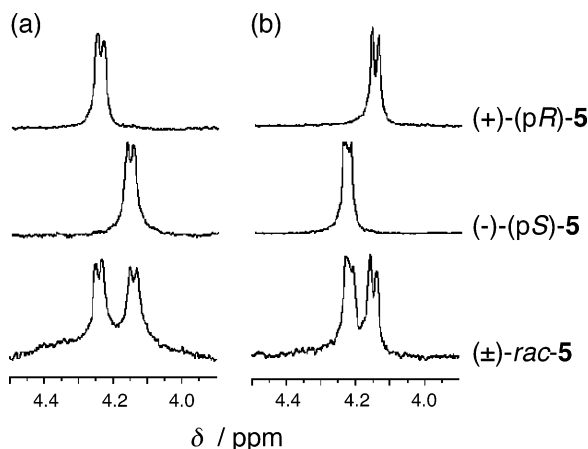
(26) Delacroix, O.; Gladysz, J. A. *Chem. Commun.* **2003**, 665.

(27) (a) Otsuka, S.; Nakamura, A.; Kano, T.; Tani, K. *J. Am. Chem. Soc.* **1971**, *93*, 4301. (b) Tani, K.; Brown, L. D.; Ahmed, J.; Ibers, J. A.; Yokota, M.; Nakamura, A.; Otsuka, S. *J. Am. Chem. Soc.* **1977**, *99*, 7876.

(28) (a) Lacour, J.; Ginglinger, C.; Grivet, C.; Bernardinelli, G. *Angew. Chem., Int. Ed.* **1997**, *36*, 608. (b) Lacour, J.; Ginglinger, C.; Grivet, C.; Bernardinelli, G. *Angew. Chem.* **1997**, *109*, 660.



**Figure 3.** Dichrograms of 0.11 mM solutions of (+)-5 and (-)-5 in methanol at 20 °C.



**Figure 4.** Enlargement of the  $^1\text{H}$  NMR (300 MHz) spectra of the + and - enantiomers of **5** (1.5 mM) in the presence of  $[\textit{n}\text{-Bu}_3\text{NH}][\Delta\text{-TRISPHAT}]$  (a), 6.1 mM) and  $[\textit{n}\text{-Bu}_4\text{N}][\Delta\text{-TRISPHAT}]$  (b), 6.1 mM) measured at 20 °C in a 1:4 mixture of  $d_6$ -acetone and  $d_6$ -benzene, respectively. The reference spectrum measured for  $(\pm)\text{-rac-5}$  displays the 1:1 splitting of the proton located at the position ortho to the palladium at the Cr-bound arene.

from chiral phase HPLC separations in a previous study by Lacour, Kündig, and co-workers.<sup>28,29</sup> A series of solutions containing these salts and *rac-5*, in various proportions and deuterated solvents, were analyzed by  $^1\text{H}$  NMR spectroscopy in order to find the optimal peak separations arising from the formation of the tightest (+)-5/TRISPHAT and (-)-5/TRISPHAT dipole-charge association complexes. We found out that the mixture of 4 equiv of TRISPHAT salts with 1 equiv of  $(\pm)\text{-5}$  dissolved in a 1:4 mixture of  $d_6$ -acetone and  $d_6$ -benzene induced, at 20 °C, a 1:1 split of the signal of one ortho proton of the Cr-bound arene ( $\Delta\delta = 0.1$  ppm), the other signals remaining mostly unchanged or only slightly broadened. Compounds (-)-5 and (+)-5 were analyzed under these conditions, and their spectra displayed only one signal ( $\delta$  4.25 and 4.15 ppm, respectively,  $^3J = 5.7$  Hz) suggesting that each sample can be considered as highly enantioenriched: e.g., with an ee higher than 96% (Figure 4).

Fortunately, both enantiomers could be crystallized and their absolute structures determined by X-ray diffraction analyses. Acquisition and refinement data

are given in Table 1. ORTEP diagrams of each structure with their atomic numbering schemes are given in Figure 5. The structural parameters of both structures, e.g. interatomic distances and angles, are in relatively good agreement with those obtained previously for the racemate  $(\pm)\text{-5}$ , which crystallized in the monoclinic crystal system with a  $P2_1/c$  space group.<sup>10</sup> The enantiomer (+)-5 was found to crystallize with one disordered molecule of  $\text{CH}_2\text{Cl}_2$  in the monoclinic system and its lattice to fit the  $P2_1$  space group: the molecular structure revealed a *pR* configuration at the ipso carbon bearing the palladium atom (see the Supporting Information).

A *pS* configuration was found for  $(-)\text{-5}\cdot\text{CH}_2\text{Cl}_2$ , which crystallizes in the orthorhombic system with a lattice fitting the  $P2_12_12_1$  space group.<sup>12</sup> In both cases, Flack's parameter was equal to 0.01 (less than 3 times the esd), indicating that the coordinates correspond to the absolute structures of the molecules in the studied crystal.<sup>30</sup> Of course, the determination of these absolute planar configurations made possible, a posteriori, the structural assignment for all the diastereomers of **8e**. Quite unexpected and disorienting was the fact that the two enantiomers crystallized in different crystal systems and space groups. From a crystallographic point of view the structures of the two enantiomers differ from each other by the orientation of the pyridine ligand bonded to the Pd(II) (Figure 6a) and by a different position of the solvating  $\text{CH}_2\text{Cl}_2$  in the unit cell, a solvent molecule that happens to be disordered in one case. This oddity was not reproduced by growing new crystals from a different mixture of solvents. The slow diffusion of acetone solutions of the same two enantiomers in *n*-hexane produced a more conventional result. The two newly obtained crystals of (-)-5 and (+)-5 were found to be almost perfect enantiomorphs, both fitting the monoclinic system and the  $P2_1$  space group (see the Supporting Information for complete acquisition and refinement data).<sup>31</sup> Figure 6b displays the superimposition of the structure of (*pS*)-5 with that of symmetry-inverted (*pR*)-5. Note

(29) (a) Ratni, H.; Jodry, J. J.; Lacour, J.; Kündig, E. P. *Organometallics* **2000**, *19*, 3997. (b) Monchaud, D.; Lacour, J.; Coudret, C.; Frayssé, S. *J. Organomet. Chem.* **2001**, *624*, 388. (c) Planas, J. G.; Prim, D.; Rose, E.; Rose-Munch, F.; Monchaud, D.; Lacour, J. *Organometallics* **2001**, *20*, 4107. (d) Pasquato, L.; Herse, C.; Lacour, J. *Tetrahedron Lett.* **2002**, *43*, 5517. (e) Hebbe, V.; Londez, A.; Goujon-Ginglinger, C.; Meyer, F.; Uziel, J.; Jugé, S.; Lacour, J. *Tetrahedron Lett.* **2003**, *44*, 2467. (f) Bruylants, G.; Bresson, C.; Boisdenghien, A.; Pierard, F.; Kirsch-De Mesmaeker, A.; Lacour, J.; Bartik, K. *New J. Chem.* **2003**, *27*, 748. (g) Wenzel, T. J.; Wilcox, J. D. *Chirality* **2003**, *15*, 256.

(30) (a) Flack, H. D.; Bernardinelli, G. *J. Appl. Crystallogr.* **2000**, *33*, 1143. (b) Flack, H. D. *Helv. Chim. Acta* **2003**, *86*, 905.

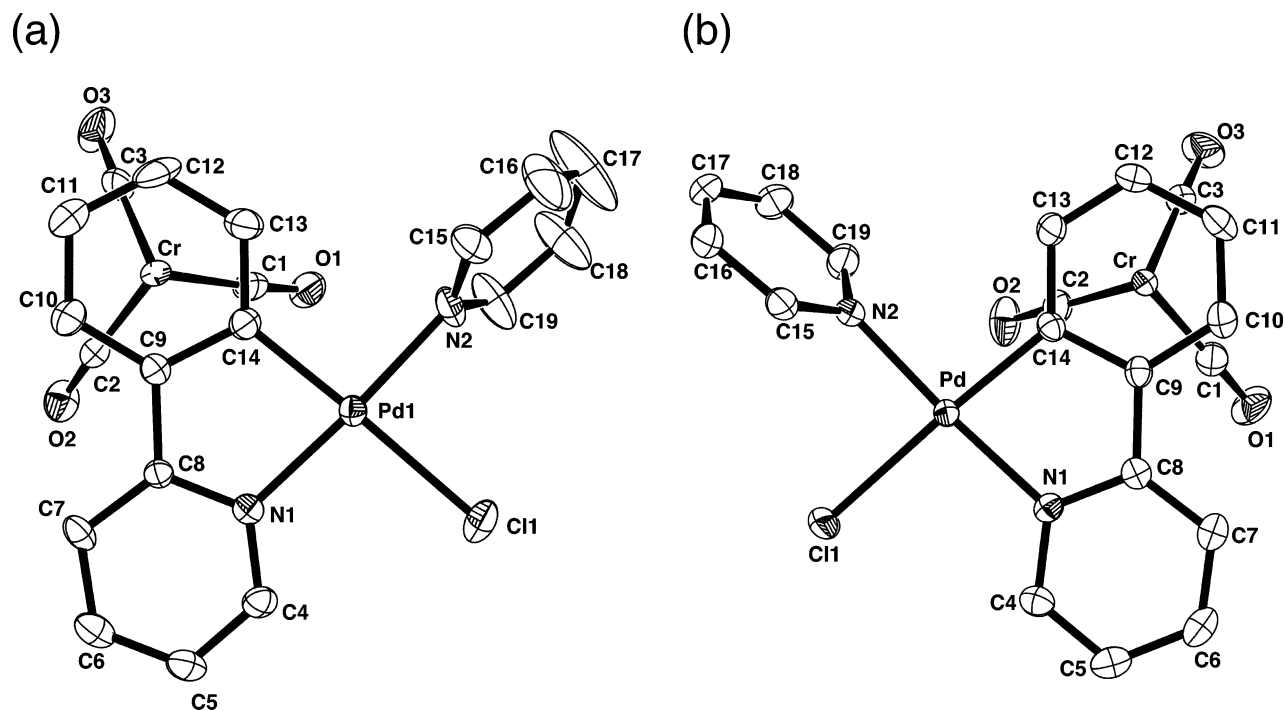
(31) (*pS*)-5· $\text{C}_2\text{H}_5\text{O}$ : formula,  $\text{C}_{22}\text{H}_{19}\text{ClCrN}_2\text{O}_4\text{Pd}$ ; molecular weight, 569.26; crystal system, monoclinic; space group,  $P2_1$ ;  $a = 6.3044(2)$  Å;  $b = 12.8799(5)$  Å;  $c = 13.7727(8)$  Å;  $\beta = 97.445(5)^\circ$ ;  $V = 1108.92(9)$  Å<sup>3</sup>;  $Z = 2$ ; color, orange; crystal dimensions,  $0.10 \times 0.10 \times 0.02$  mm;  $D_{\text{calc}} = 1.70$  g cm<sup>-3</sup>;  $F_{000} = 568$ ;  $\mu = 1.452$  mm<sup>-1</sup>; minimum/maximum transmission, 0.9670/1.0000;  $T = 173$  K;  $hkl$  limits, -6, to +6, -16 to +15, -17 to +17;  $\theta$  limits, 2.5–27.48°; 3860 data measured; 3144 data with  $I > 3\sigma(I)$ ; 279 variables;  $R = 0.030$ ;  $R_w = 0.033$ ; GOF = 1.044; largest peak in final difference, 0.820 e Å<sup>-3</sup>; Flack  $x$  parameter, 0.01(-4). (*pR*)-5· $\text{C}_2\text{H}_5\text{O}$ : formula,  $\text{C}_{22}\text{H}_{19}\text{ClCrN}_2\text{O}_4\text{Pd}$ ; molecular weight, 569.26; crystal system, monoclinic; space group,  $P2_1$ ;  $a = 6.3067(2)$  Å;  $b = 12.8659(5)$  Å;  $c = 13.7717(7)$  Å;  $\beta = 97.482(3)^\circ$ ;  $V = 1107.94(8)$  Å<sup>3</sup>;  $Z = 2$ ; color, orange; crystal dimensions,  $0.10 \times 0.10 \times 0.08$  mm;  $D_{\text{calc}} = 1.71$  g cm<sup>-3</sup>;  $F_{000} = 568$ ;  $\mu = 1.454$  mm<sup>-1</sup>; minimum/maximum transmission, 0.9570/1.0000;  $T = 173$  K;  $hkl$  limits, -8, to +8, -18 to +16, -19 to +19;  $\theta$  limits, 2.5/30.03°; 5264 data measured; 4296 data with  $I > 3\sigma(I)$ ; 279 variables;  $R = 0.030$ ;  $R_w = 0.031$ ; GOF = 1.033; largest peak in final difference, 0.771 e Å<sup>-3</sup>; Flack  $x$  parameter, -0.01(3).



**Table 1.** Table of Acquisition and Refinement Data Collected for Complexes **8a**, **8b**, *u-8c*, (*7R*)-*u-8d*, (*7S*)-**8c**, (*pR*)-**5**, and (*pS*)-**5**<sup>a</sup>

	<b>8a</b>	<b>8b</b>	<i>u-8c</i>	( <i>7R</i> )- <i>u-8d</i>	( <i>7S</i> )- <b>8c</b>	( <i>pR</i> )- <b>5</b>	( <i>pS</i> )- <b>5</b>
formula	C <sub>23</sub> H <sub>20</sub> Cr-N <sub>2</sub> O <sub>3</sub> Pd	C <sub>25</sub> H <sub>16</sub> Cr-N <sub>2</sub> O <sub>3</sub> Pd	C <sub>26</sub> H <sub>20</sub> Cr <sub>2</sub> N <sub>2</sub> -O <sub>6</sub> Pd·CH <sub>2</sub> Cl <sub>2</sub>	C <sub>27</sub> H <sub>22</sub> Cr <sub>2</sub> -N <sub>2</sub> O <sub>6</sub> Pd	C <sub>48</sub> H <sub>44</sub> Cr <sub>2</sub> -N <sub>4</sub> O <sub>6</sub> Pd <sub>2</sub>	C <sub>19</sub> H <sub>13</sub> ClCrN <sub>2</sub> -O <sub>3</sub> Pd·CH <sub>2</sub> Cl <sub>2</sub>	C <sub>19</sub> H <sub>13</sub> ClCrN <sub>2</sub> -O <sub>3</sub> Pd·CH <sub>2</sub> Cl <sub>2</sub>
mol wt	530.82	550.81	751.78	680.88	1089.70	596.11	596.11
cryst syst	monoclinic	monoclinic	monoclinic	orthorhombic	monoclinic	monoclinic	orthorhombic
space group	<i>P2<sub>1</sub>/n</i>	<i>C2/c</i>	<i>P2<sub>1</sub>/n</i>	<i>P2<sub>1</sub>2<sub>1</sub>2<sub>1</sub></i>	<i>P2<sub>1</sub></i>	<i>P2<sub>1</sub></i>	<i>P2<sub>1</sub>2<sub>1</sub>2<sub>1</sub></i>
<i>a</i> (Å)	11.0250(3)	28.457(2)	11.9974(2)	10.2721(2)	11.1217(3)	6.4747(2)	18.0316(3)
<i>b</i> (Å)	16.3553(4)	11.4642(8)	16.7208(2)	12.4607(2)	17.0324(4)	12.4324(3)	18.0653(3)
<i>c</i> (Å)	11.6928(3)	14.7537(9)	14.3988(3)	20.8988(4)	11.5570(3)	14.0935(5)	6.6008(1)
$\beta$ (deg)	103.800(5)	95.678(5)	98.483(5)		102.118(5)	96.103(5)	
<i>V</i> (Å <sup>3</sup> )	2047.55(9)	4789.6(5)	2856.89(8)	2675.00(8)	2140.45(9)	1128.04(6)	2150.19(6)
<i>Z</i>	4	8	4	4	2	2	4
color	yellow	orange	red	orange	orange	orange	orange
cryst dimens (mm)	0.08 × 0.08 × 0.04	0.18 × 0.14 × 0.01	0.20 × 0.12 × 0.10	0.20 × 0.16 × 0.14	0.20 × 0.14 × 0.14	0.20 × 0.16 × 0.10	0.20 × 0.08 × 0.03
<i>D</i> <sub>calcd</sub> (g cm <sup>-3</sup> )	1.72	1.53	1.75	1.69	1.69	1.75	1.84
<i>F</i> <sub>000</sub>	1064	2192	1496	1360	1096	588	1176
$\mu$ (mm <sup>-1</sup> )	1.437	1.232	1.601	1.507	1.377	1.658	1.739
transmissn min/max	0.8935/1.0000	0.8539/1.0000	0.9597/1.0000	0.9759/1.1181	0.9609/1.0000	0.9592/1.0000	0.9449/1.0000
<i>hkl</i> limits	-15 to +15, -19 to +23, -16,16	-36 to +36, -14 to +13, -17 to +17	-16 to +16, -22 to +23, -20 to +20	-14 to +14, -17 to +17, -29 to +29	-7 to +15, -20 to +23, -15 to +16	-9 to +9, -17 to +17, -19 to +19	-25 to +25, -25 to +25, -9 to +9
$\theta$ limits (deg)	2.5–30.00	2.5–27.47	2.5–30.04	2.5–30.03	2.5–30.03	2.5–30.04	2.5–30.03
no. of data measd	9793	8042	15 912	7821	12 332	6353	6317
no. of data with <i>I</i> > 3 $\sigma$ ( <i>I</i> )	3421	2346	5810	3612	4310	2879	5347
no. of variables	271	289	361	343	558	255	271
<i>R</i>	0.032	0.056	0.025	0.025	0.030	0.040	0.030
<i>R</i> <sub>w</sub>	0.032	0.087	0.030	0.031	0.046	0.057	0.036
GOF	0.968	1.043	1.021	1.018	1.046	1.129	1.037
largest peak in final diff map (e Å <sup>-3</sup> )	0.620	0.832	0.430	0.374	0.424	1.137	0.893

<sup>a</sup> Reflections were collected at 173 K with a Nonius KappaCCD diffractometer using the Mo K $\alpha$  graphite-monochromated radiation ( $\lambda = 0.710 73$  Å).

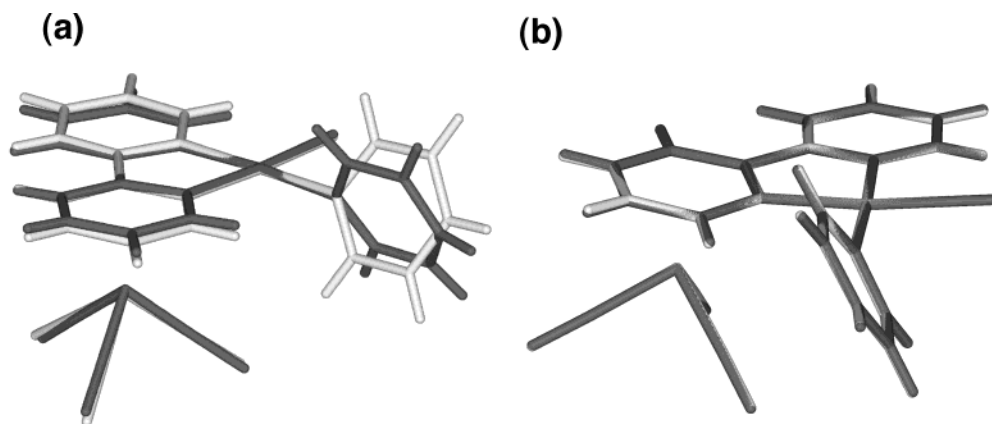


**Figure 5.** Atom-numbering schemes and ORTEP diagrams of the structures of (a) (+)-(*pR*)-**5** and (b) (-)-(*pS*)-**5** drawn at the 30% probability level. Hydrogen atoms and molecules of CH<sub>2</sub>Cl<sub>2</sub> have been omitted for clarity purposes.

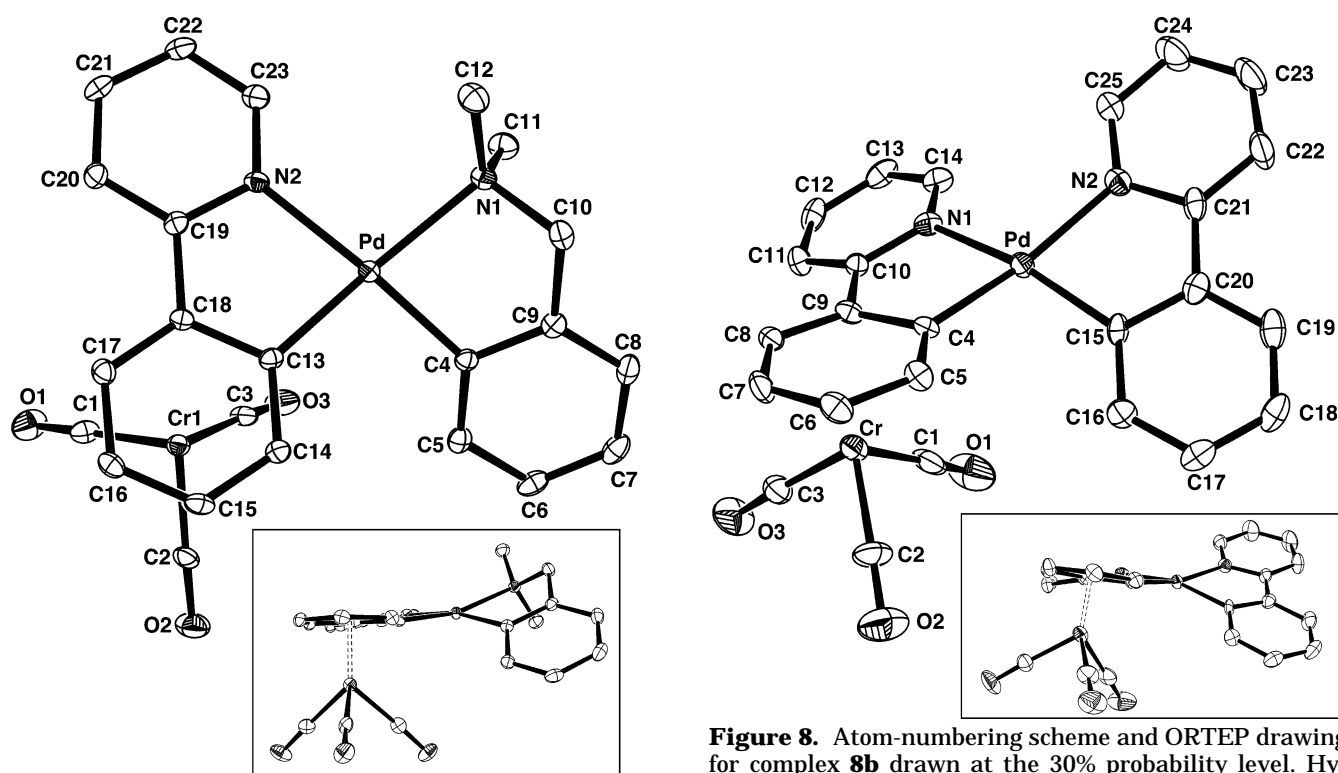
that, in these two structures, **5** is solvated by one molecule of acetone.

**Molecular Structures of Homo- and Heteroheptic Cis Bis-Chelated Pd(II) Complexes.** We succeeded in obtaining crystals of complexes **8a** (Figure 7), **8b**

(Figure 8), (*rel*)-*u-8c* (Figure 9), (*7R*)-*u-8d* (Figure 10), and (*7R*)- and (*7S*) *endo-8e* and *exo-8e* by the slow diffusion of concentrated dichloromethane solutions of each solute in *n*-hexane at -20 °C. Table 1 lists pertinent acquisition and refinement data for complexes



**Figure 6.** Accelerlys ViewerPro drawings of the superimposed structures of inverted (+)-(p*R*)-5 (dark gray) and (-)-(p*S*)-5 (light gray): (a) from the nonenantiomorphic structures containing one molecule of dichloromethane per complex; (b) from the enantiomorphic structures containing one molecule of acetone per complex. Molecules of solvents have been omitted for the sake of clarity.



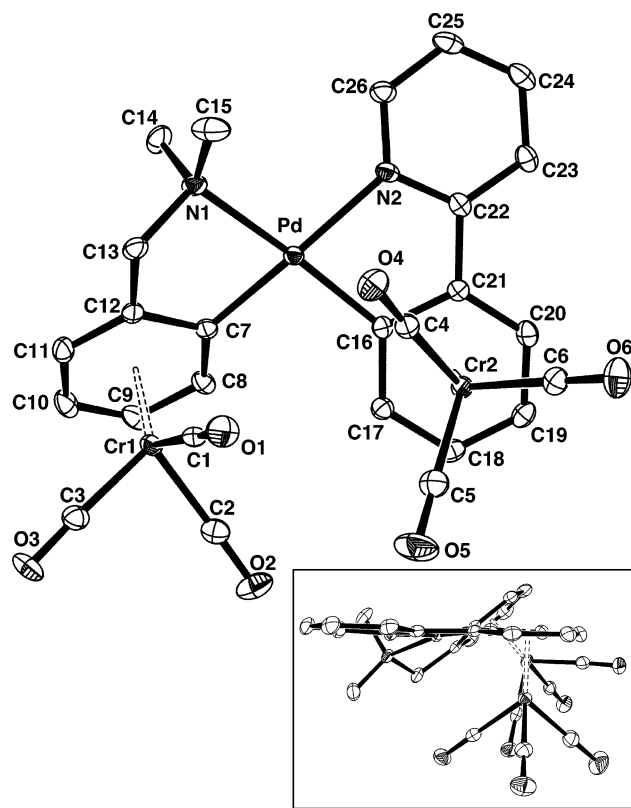
**Figure 7.** Atom-numbering scheme and ORTEP drawing for complex **8a** drawn at the 30% probability level. Hydrogen atoms have been omitted for clarity purposes. Selected interatomic distances (Å) and angles (deg): Cr1–Pd, 3.984(3); Cr1–C3, 2.288(3); N2–Pd, 2.146(3); N1–Pd, 2.193(3); C4–Pd, 2.004(3); C13–Pd, 1.987(3); C5–C4–C9, 117.0(3); C18–C13–C14, 121.7(3); N2–Pd–N1, 102.3(1); C13–Pd–C4, 97.9(1); N2–Pd–C13, 81.0(1); N1–Pd–C4, 82.0(1).

**8a–e** (complete data for (7*R*)-**8e** are given in the Supporting Information). As mentioned previously, the couple of diastereomers of both (7*S*)- and (7*R*)-**8e** cocrystallized in a pseudo centrosymmetric space group. Figures 11 and 12 display the structures of the two diastereomers of (7*S*)-**8e** extracted from a single set of data. The main structural property of these heteroleptic complexes is the distorted-square-planar coordination geometry around the Pd(II) center. This distortion is explained by the steric strain existing between the proximal aryls of the bis-chelate, which tilts them to

**Figure 8.** Atom-numbering scheme and ORTEP drawing for complex **8b** drawn at the 30% probability level. Hydrogen atoms have been omitted for clarity purposes. Selected interatomic distances (Å) and angles (deg): Cr–Pd, 4.02(1); Cr–C4, 2.29(1); Cr–C5, 2.25(1); Cr–C8, 2.19(1); N1–Pd, 2.13(1); C4–Pd, 1.99(1); C15–Pd, 2.00(1); N2–Pd, 2.11(1); N1–Pd, 2.13(1); C9–C4–C5, 114(1); C16–C15–C20, 115(1).

opposite faces of the mean plane containing the palladium. This feature was already reported, in the past, in numerous examples of cis bis-chelated Pd(II) and Pt(II) complexes and elegantly used by von Zelewsky and co-workers for the synthesis of enantiopure helical objects.<sup>32</sup> One must also mention the appealing application by Yamaguchi and co-workers of Pt(II) bis-chelated homoleptic complexes as helical building blocks for the synthesis of helical inorganic polymers in which the Pt

(32) (a) Deuschel-Cornioley, C.; Stoeckli-Evans, H.; von Zelewsky, A. *J. Chem. Soc., Chem. Commun.* **1990**, 121. (b) Gianini, M.; Forster, A.; Haag, P.; von Zelewsky, A.; Stoeckli-Evans, H. *Inorg. Chem.* **1996**, *35*, 4889. (c) Gianini, M.; von Zelewsky, A.; Stoeckli-Evans, H. *Inorg. Chem.* **1997**, *36*, 6094.



**Figure 9.** Atom-numbering scheme and ORTEP drawing for (*rel*)-*u*-**8c** drawn at the 30% probability level. Hydrogen atoms and the solvating molecule of  $\text{CH}_2\text{Cl}_2$  have been omitted for clarity purposes. Selected interatomic distances (Å) and angles (deg): Cr1–Pd, 4.012(2); Cr2–Pd, 3.740(2); Cr1–C7, 2.287(2); Cr2–C16, 2.276(2); C7–Pd, 2.001(2); N1–Pd, 2.178(2); N2–Pd, 2.124(2); C16–Pd, 1.993(2); Pd–Cr1, 4.012(2); Pd–Cr2, 3.740(2); C7–Pd–C16, 98.22(8); C7–Pd–N1, 81.45(8); N1–Pd–N2, 101.07(7); N2–Pd–C16, 81.20(8).

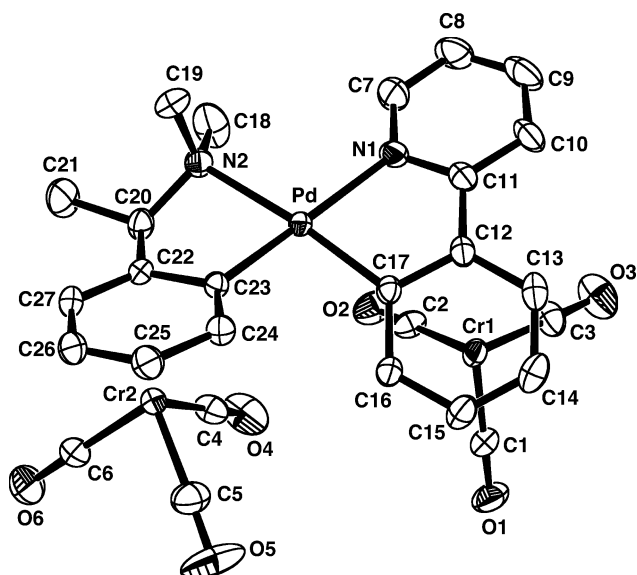
center intervenes as a ditopic “double-sided” Lewis base.<sup>33</sup>

The helical distortion of the square plane, or twist, can be roughly quantified by the determination of the interplanar angle  $\Psi$  between the two chelation planes defined by the carbon, nitrogen, and palladium atoms of each chelate (Figure 13). Table 2 gives the value of  $\Psi$  for a series of published bis-chelates of Pd(II) and Pt(II) as well as for those described in the present article. It is clear that the presence of a  $\text{Cr}(\text{CO})_3$  moiety increases dramatically the torsion of the system of about  $10^\circ$  with respect to the three cases of mononuclear Pd and Pt complexes **11**,<sup>34</sup> **12**, and **13**,<sup>35</sup> whose data were extracted from the Cambridge Crystallographic Database (Chart 3). The peculiar propensity of the aryl group adjacent to the Cr-bound arene to point toward the  $\text{Cr}(\text{CO})_3$  rotor and not, as one might have expected, outward to minimize steric interactions can be added as yet another peculiarity of these polynuclear species. Strikingly, this orientation is observed in all six cases of binuclear (Cr,Pd) bis-chelated complexes that were crystallized and analyzed by X-ray diffraction.

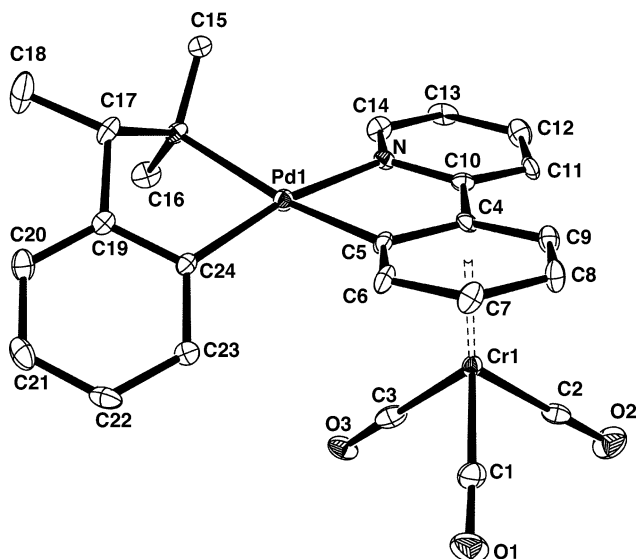
(33) Yamaguchi, T.; Yamazaki, F.; Ito, T. *J. Am. Chem. Soc.* **2001**, *123*, 743.

(34) Fuchita, Y.; Yoshinaga, K.; Hanaki, T.; Kawano, H.; Kinoshita-Nagaoka, J. *J. Organomet. Chem.* **1999**, *580*, 273.

(35) Chassot, L.; Müller, E.; von Zelewsky, A. *Inorg. Chem.* **1984**, *23*, 4249.

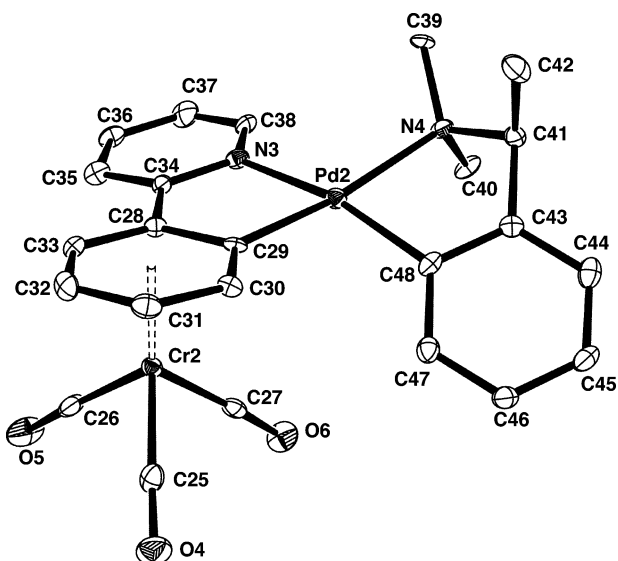


**Figure 10.** Atom-numbering scheme and ORTEP drawing for complex (*7R*)-*u*-**8d** drawn at the 30% probability level. Hydrogen atoms have been omitted for clarity purposes. Selected interatomic distances (Å) and angles (deg): Cr2–Pd, 4.000(5); Cr1–Pd, 3.887(5); Cr1–C17, 2.300(5); Cr2–C23, 2.268(5); Cr1–C14, 2.245(4); Cr2–C26, 2.226(4); C23–Pd, 2.000(3); N2–Pd, 2.144(3); N1–Pd, 2.162(3); C17–Pd, 1.978(3); Pd–Cr1, 3.887(5); Pd–Cr2, 4.000(5); C22–C23–C24, 117.5(3); C12–C17–C16, 117.2(3); C17–Pd–C23, 96.0(1).

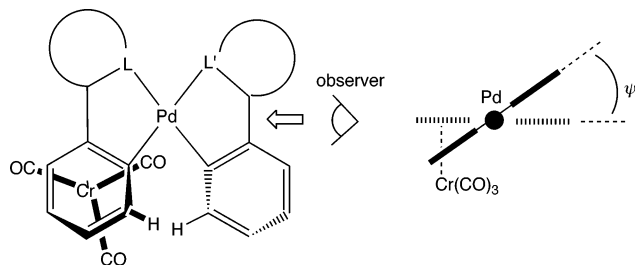


**Figure 11.** Atom-numbering scheme and ORTEP diagram of (*7S*)-*endo*-**8e** extracted from the structure of the two cocrystallized diastereomers and drawn at the 30% probability level. Hydrogen atoms have been omitted for clarity reasons. Selected interatomic distances (Å) and angles (deg): Cr1–Pd, 3.99(1); Cr1–C5, 2.290(9); Cr1–C7, 2.20(1); Cr1–C4, 2.28(1); C5–Pd1, 1.98(1); N1–Pd1, 2.149(9); N2–Pd1, 2.187(8); C24–Pd1, 2.00(1); C6–C5–C4, 116.3(9); N1–Pd1–N2, 102.3(3); N2–Pd1–C24, 81.6(4); C24–Pd1–C5, 97.5(4); C5–Pd1–N1, 81.5(4); C19–C24–C23, 119(1).

In a first approach to this problem, one could assume that such a conformation of the bis-chelate stems from a  $\text{C–H}\cdots[\text{Cr}(\text{CO})_3]$  interaction. In complex **8b**, the close contacts measured between the two phenyl groups would suggest a diffuse multicenter interaction that



**Figure 12.** Atom-numbering scheme and ORTEP diagram of (7*S*)-*exo*-**8e** extracted from the structure of the two cocrystallized diastereomers and drawn at the 30% probability level. Hydrogen atoms have been omitted for clarity reasons. Selected interatomic distances (Å) and angles (deg): Cr2–Pd2, 4.00(1); Cr2–C29, 2.295(9); Cr2–C30, 2.235(9); Cr2–C28, 2.25(1); Cr2–C31, 2.21(1); C29–Pd2, 2.00(1); C48–Pd2, 2.01(1); N3–Pd2, 2.165(9); N4–Pd2, 2.186(8); N3–Pd2–N4, 103.6(3); N3–Pd2–C29, 79.9(4); C29–Pd2–C48, 98.6(4); N4–Pd2–C48, 81.1(4).



**Figure 13.** Distortion of the square-planar coordination geometry at the Pd atom: definition of the torsion angle  $\psi$ .

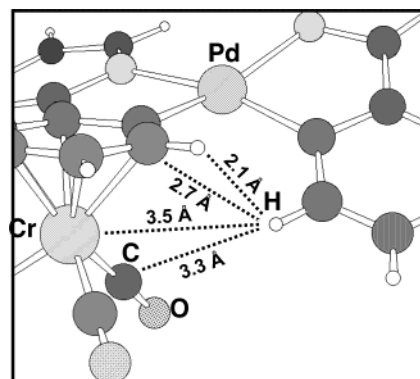
**Table 2. Values of Torsion Angle  $\psi$  for Several Bis-Chelated Palladium and Platinum Complexes**

	11	12	13	8a	8b	<i>endo</i> - <b>8e</b>	<i>exo</i> - <b>8e</b>	<i>ul-6</i>	<i>ul-8c</i>	<i>ul-8d</i>
$\psi$ (deg)	6.8	8.6	4.0	20.7	23.6	20.0	21.0	24.0	16.3	17.3

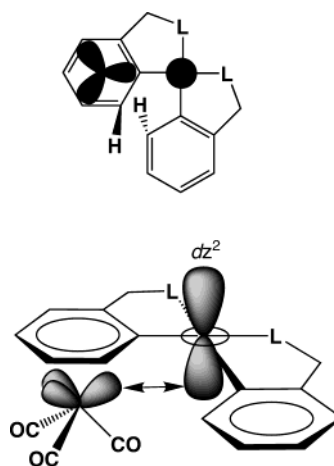
involves the ortho hydrogen of the proximal aryl group and at least two other centers, i.e., the chromium and the carbon atoms of one CO ligand that syn-eclipses the Pd (Figure 14). If the values of the interatomic distances are compared to the data collected for other reported cases of established intermolecular C–H $\cdots$ CO interaction, in **8b** they fall far from what is actually expected for a strong interaction.<sup>36</sup> The reason for the endo tilting of the aryl group toward the Cr(CO)<sub>3</sub> therefore does not seem to be a weak intramolecular interaction.

This peculiar distortion of the square plane reported here very likely stems from an electronic repulsion between the nonbonding populated  $d_z^2$  orbital centered at the Pd atom<sup>37</sup> and a nonbonding populated hybrid

(36) Brown, M.; Zubkowsky, J. D.; Valente, E. J.; Yang, G. Z.; Henry, W. P. *J. Organomet. Chem.* **2000**, *613*, 111.



**Figure 14.** Enlarged view of the endo tilting of the phenyl fragment toward the Cr(CO)<sub>3</sub> moiety in **8b**. The dashed lines indicate the shortest distances separating the H atom of the endo phenyl fragment from the vicinal Cr-bound arene.



**Figure 15.** Nonbonding occupied orbitals putatively responsible for the endo tilting of the chelating ligand adjacent to the Cr-bound one.

orbital located at the Cr atom,<sup>38</sup> of which one of the three lobes of which points toward the ipso position bearing the Pd(II) center.

A slight “endo” tilting of the Cr-free chelate sends the lower lobe of the  $d_z^2$  orbital far from the Cr(CO)<sub>3</sub> fragment and minimizes the repulsive interaction (Figure 15). An “exo” tilting places the chelating ligand above the Cr-bound arene and sends the lower lobe of the  $d_z^2$  orbital toward the Cr(CO)<sub>3</sub> group.

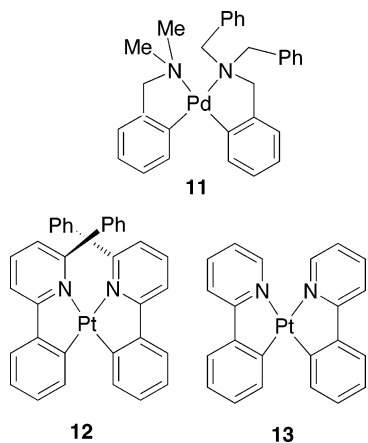
Strong electronic repulsion between the Cr(CO)<sub>3</sub> group and mesomeric donor substituents can cause a slight folding of the arene ligand.<sup>39</sup> In the cases reported here, such a distortion of the Cr-bound arene is not noticed. To the best of our knowledge, what is witnessed here in the solid state is an unprecedented electronically induced oriented distortion of the square-planar coordination geometry around the Pd(II) center. Preliminary <sup>1</sup>H and <sup>13</sup>C NMR studies of solutions of *u-6* at 213 K did not reveal any slowed rotation of the cluttered Cr-

(37) Aullon, G.; Alvarez, S. *Inorg. Chem.* **1996**, *35*, 3137.

(38) Muettterties, E. L.; Bleeke, J. R.; Wucherer, E. J.; Albright, T. A. *Chem. Rev.* **1982**, *82*, 499.

(39) (a) Hunter, A. D.; Shilliday, L.; Furey, W. S.; Zaworotko, M. J. *Organometallics* **1992**, *11*, 1550. (b) Hunter, A. D.; Mozol, V.; Tsai, S. D. *Organometallics* **1992**, *11*, 2251. (c) Djukic, J. P.; Rose-Munch, F.; Rose, E.; Vaissermann, J. *Eur. J. Inorg. Chem.* **2000**, 1295. (d) Suresh, C. H.; Koga, N.; Gadre, S. R. *Organometallics* **2000**, *19*, 3008.

Chart 3

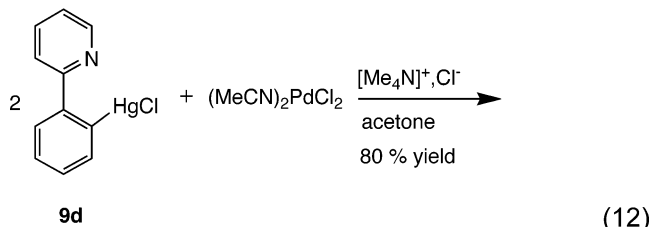
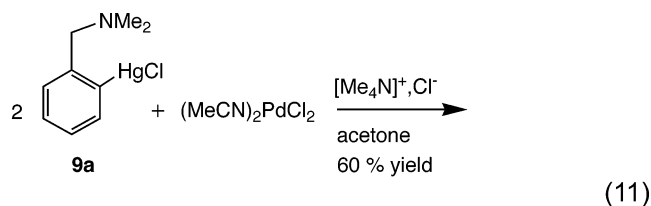


(CO)<sub>3</sub> moiety. The <sup>13</sup>C nuclei of the two Cr(CO)<sub>3</sub> groups in **u-6** are isochronous and give a singlet at 235.1 ppm.

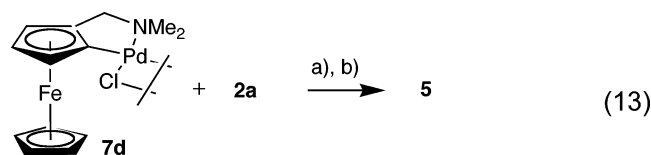
### Concluding Remarks

Homo- and heteroleptic bis-chelated Pd(II) complexes can be synthesized by several methods that are based on the transmetalation of metalated C–L type (L = N, O, P) chelating ligands with electrophilic Pd salts.<sup>40–42</sup> In almost all cases, the sole products of the transmetalation reaction are the cis isomers. Several authors stated that the origin of this stereoselectivity lies in the lower steric strains observed in cis stereoisomers as compared to trans isomers.<sup>40e,h,i</sup> Using these methods, homoleptic palladium complexes can be obtained in yields ranging from 20 up to 90% in some cases,<sup>40c,h</sup> whereas the synthesis of heteroleptic complexes is much less convenient for the formation of homoleptic complexes, as byproducts cannot be completely avoided in most cases.<sup>40e</sup> We have described here a method of synthesis of stable heteroleptic complexes based on the use of mercurated substrates and cyclopalladated aromatics, which in some ways complements the early studies of Vicente and co-workers on simpler systems.<sup>41</sup> We also verified the validity of this method for the synthesis of simple homoleptic Pd(II) complexes such as **14a** (eq 11) and **14b** (eq 12).

The one-pot reaction of 2 equiv of complexes **9a** and **9d**, respectively, with (MeCN)<sub>2</sub>PdCl<sub>2</sub> in the presence of large amounts of [Me<sub>4</sub>N]Cl in acetone at room temperature yielded the two homoleptic complexes in good yields. Their analytical data were found to agree with



those of original samples prepared according to less efficient published procedures.<sup>40a,h</sup> It is worth noting that attempts at obtaining heteroleptic Pd(II) complexes from **2a** and the ferrocene-derived Pd(II) chelate **7d**,<sup>43</sup> in the presence of a large excess of Cl<sup>-</sup>, only resulted in the quantitative formation of **5** upon quenching with pyridine (eq 13).



a) excess [NMe<sub>4</sub>N]Cl, acetone, -20 °C. b) pyridine.

Scheme 10 summarizes our findings on the mechanism of formation of bis-chelated Pd(II) compounds from **2a**, [NMe<sub>4</sub>N]Cl, and a bis( $\mu$ -chloro) palladacycle. The persistence of the Pd(II) bis-chelate is clearly conditioned by the balance existing between the relative rates of those reactions that create (transformations C and D, Scheme 10) and consume it (transformations F and G, Scheme 10). The chloride salt, which ensures the continuous trapping of HgCl<sub>2</sub> (equilibrium B, Scheme 10), the steady formation of **3** (path A, Scheme 10) and the equilibrated monomerization of the chloropalladacycle (equilibrium E, Scheme 10), plays a key role. In the reactions leading to **8a,b** and **8e**, processes designated by letters F and G are obviously inefficient under the conditions we have used, probably because the

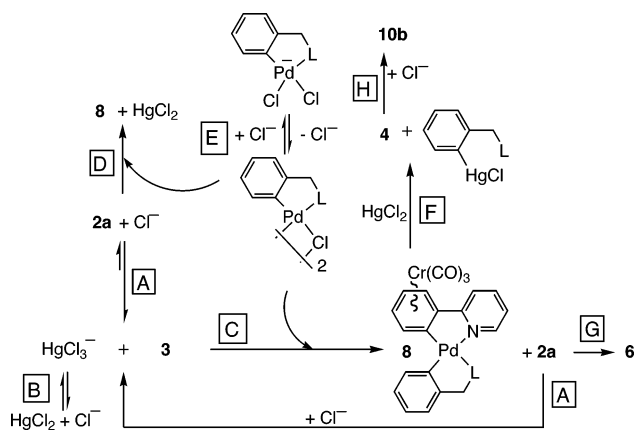
(40) (a) Kasahara, A.; Izumi, T. *Bull. Chem. Soc. Jpn.* **1969**, *42*, 1765. (b) Longoni, G.; Fantucci, P.; Chini, P.; Canziani, F. *J. Organomet. Chem.* **1972**, *39*, 413. (c) Abicht, H. P.; Issleib, K. *J. Organomet. Chem.* **1980**, *185*, 265. (d) Dehand, J.; Mauro, A.; Ossor, H.; Pfeffer, M.; Santos, R. H.; Lechat, J. R. *J. Organomet. Chem.* **1983**, *250*, 537. (e) Janecki, T.; Jeffreys, J. A. D.; Pauson, P. L.; Pietrzykowski, A.; McCullough, K. J. *Organometallics* **1987**, *6*, 1553. (f) Maassarani, F.; Pfeffer, M.; Le Borgne, G.; Jastrzebski, J. T. B. H.; van Koten, G. *Organometallics* **1987**, *6*, 1111. (g) Cornioley-Deuschel, C.; von Zelewsky, A. *Inorg. Chem.* **1987**, *26*, 3354. (h) Jolliet, P.; Gianini, M.; von Zelewsky, A.; Bernardinelli, G.; Stoeckli-Evans, H. *Inorg. Chem.* **1996**, *35*, 4883. (i) Fuchita, Y.; Yoshinaga, K.; Hanaki, T.; Kawano, H.; Kinoshita-Nagaoka, J. *J. Organomet. Chem.* **1999**, *580*, 273.

(41) (a) Vicente, J.; Chicote, M. T.; Martin, J.; Artigao, M.; Solans, X.; Font-Altaba, M.; Aguiló, M. *J. Chem. Soc., Dalton Trans.* **1988**, 141. (b) Sokolov, V. I.; Troitskaya, L. L.; Reutov, O. A. *J. Organomet. Chem.* **1975**, *93*, C11.

(42) Valk, J. M.; Boersma, J.; van Koten, G. *Organometallics* **1996**, *15*, 4366.

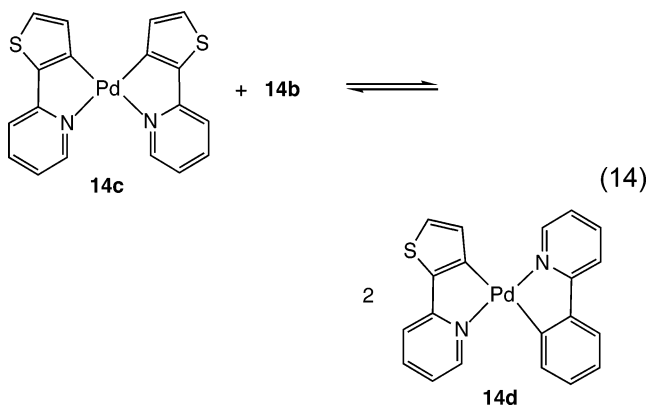
(43) (a) Lednicer, D.; Hauser, C. R. *Org. Synth.* **1960**, *40*, 31. (b) Gaunt, J. C.; Shaw, B. L. *J. Organomet. Chem.* **1975**, *102*, 511.

Scheme 10



electron-withdrawing Cr(CO)<sub>3</sub> moiety deactivates the Pd(II) center toward electrophilic attacks. However, one must expect these steps to predominate whenever the Pd(II) is “richer” in electron density, which might be the reason why we have not recovered any heteroleptic bis-chelated species in the reaction of **2a** with **7d**. Both reactions C and D have their rates limited by the amount of electrophilic palladium dimer released in solution upon displacement of the monoanionic palladate, which must affect the relative rate of the transmetalation step.

The chemical stability of bis-chelated Pd(II) complexes was probed by many authors, who focused essentially on the behavior of these electron-rich complexes toward various sorts of electrophiles. One interesting property, which has been addressed for the first time by von Zelewsky and co-workers, is the chemical fluxionality of bis-chelated palladium(II) complexes such as **14b,c** and their ability to cross-exchange chelating units and give **14d** (eq 14).<sup>40h</sup>



None of the heteroleptic binuclear bis-chelated Pd(II) complexes that we report in this paper underwent such a spontaneous disproportionation in solution, even after several days of stirring at room temperature. In fact, we found it difficult to discriminate between the result of a departure of the Cr(CO)<sub>3</sub> moiety and that of a disproportionation reaction. However, we could observe a ligand exchange in the stoichiometric reaction of **8a** with **14b**, which afforded a new mixture containing 50 mol % of complexes **8b**, **8a**, and **14b** as well as other unidentified species, after 3 h of stirring at room temperature (eq 15).



In our opinion the electron-withdrawing effect of the Cr(CO)<sub>3</sub> group associated with its bulkiness makes the cleavage of C–Pd bonds less likely than in mononuclear “Cr-free” species. Only the exchange of ligand leading to a less electron-rich but strongly chelated Pd center operates, as exemplified by the latter reaction of **8a** with **14b**. This information would be consistent with a mechanism implying a “face to face” approach of the two bis-chelated Pd(II) complexes as proposed previously by von Zelewsky and co-workers.<sup>40h</sup>

In conclusion, almost enantiopure, planar chiral complexes derived from 2-phenylpyridine can readily be obtained by the method described here. This methodology offers great advantages over other known methods of introduction of planar chirality applied to similar Cr complexes.<sup>3c</sup> The synthesis of compounds such as **8e** does not require extreme low temperatures and high-grade dry solvents. Provided that extreme caution is applied in the handling and disposal of toxic mercury derivatives and wastes, both organomercury and -palladium substrates are readily available from very simple procedures; they display a relative inertness to air and moisture, which allows their storage over long periods of time. In the future, we shall concentrate our efforts on establishing further alternative routes to enantioenriched, planar chiral metalated complexes that use the methods described in this article.

## Experimental Section

All experiments were carried out under a dry atmosphere of argon, with dry and degassed solvents. Chloromercurated and cyclopalladated compounds such as **2a**, (7*S*)-**9c**, **4**,<sup>10</sup> bis-(*μ*-chloro)(*N,N*-dimethylbenzylamine-2*C,N*)dipalladium(II) (**7a**),<sup>14</sup> (+)- and (–)-bis(*μ*-chloro)[(*S*)- and (*R*)-*N,N*-dimethyl-*α*-phenylethylamine-2*C,N*]dipalladium(II) (**7c**),<sup>27</sup> and **7b**<sup>44</sup> were synthesized according to published procedures. Neutral silica gel (Si 60, 40–63 μm) for column chromatography was purchased from Merck and tetramethylammonium chloride from Avocado. NMR spectra were acquired with Bruker DRX 500 (<sup>13</sup>C and <sup>1</sup>H nuclei) and Bruker AV-300 (<sup>1</sup>H) spectrometers at room temperature unless otherwise stated. Chemical shifts are reported in parts per million downfield of Me<sub>4</sub>Si. IR spectra were measured on a Perkin-Elmer FT spectrometer. Elemental analyses (reported in percent mass) were performed at the analytical centers of “Université Louis Pasteur” and the “Institut Charles Sadron” in Strasbourg. CD spectra were recorded in Geneva with a JASCO JR 7 spectropolarimeter using 1 cm optical length quartz cells. Δε is expressed in units of cm<sup>2</sup> mmol<sup>–1</sup>. High-resolution mass spectra were carried out with the fast atom bombardment (FAB) method, and electro-spray mass spectra were acquired in the negative mode at the “Service de Spectrométrie de Masse de Strasbourg”.

**Experimental Procedure for the X-ray Diffraction Analysis of Compounds 8a, 8b, u-8c, (7*R*)-u-8d, (7*S*)-8e, (7*R*)-8e, (p*R*)-5·CH<sub>2</sub>Cl<sub>2</sub>, and (p*S*)-5·CH<sub>2</sub>Cl<sub>2</sub>.** Acquisition and processing parameters are displayed in Table 1. Reflections were collected with a Nonius KappaCCD diffractometer using Mo K<sub>α</sub> graphite-monochromated radiation (λ = 0.710 73 Å). The structures were solved using direct methods; they were refined against |*F*|, and for all pertaining computations, the

(44) (a) Kasahara, A. *Bull. Chem. Soc. Jpn.* **1968**, *41*, 1272. (b) Constable, E. C.; Thompson, A. M. W. C.; Leese, T. A.; Reese, D. G. F.; Tocher, D. A. *Inorg. Chim. Acta* **1991**, *182*, 93.

Nonius OpenMoleN package was used.<sup>45</sup> Hydrogen atoms were introduced as fixed contributors. The absolute structures of (7*R*)-**u-8d** ( $x = 0.03(3)$ ), (7*S*)-**8e** ( $x = 0.03(3)$ ), (7*R*)-**8e** ( $x = 0.01(2)$ ), (p*R*)-**5**·CH<sub>2</sub>Cl<sub>2</sub> ( $x = -0.04(5)$ ), and (p*S*)-**5**·CH<sub>2</sub>Cl<sub>2</sub> ( $x = -0.05(5)$ ) were determined by refining the corresponding Flack  $x$  parameters.

**[Tricarbonyl( $\eta^6$ -1-(iodomercuro)phenyl)chromium]pyridine (**2b**).** A solution of **1** (300 mg, 1.03 mmol) and Hg(OAc)<sub>2</sub> (394 mg, 1.24 mmol) in EtOH (15 mL) was stirred at reflux over 3 h under argon. The resulting medium was cooled to room temperature and filtered over Celite. Then, [*n*-Bu<sub>4</sub>N]I (380 mg, 1.03 mmol) was added and the mixture stirred for 30 min. A yellow-orange solid, which precipitated upon addition of H<sub>2</sub>O, was filtered, washed several times with water, and dried under vacuum. Flash chromatography over silica gel, with a mixture of 50–60% CH<sub>2</sub>Cl<sub>2</sub> in hexane, afforded the orange-yellow complex **2b** (320 mg, 0.52 mmol, 50% yield). HRMS: calcd for C<sub>14</sub>H<sub>8</sub>NO<sub>3</sub>I<sup>52</sup>Cr<sup>199</sup>Hg, 615.8636; found, 615.8637. IR (CH<sub>2</sub>Cl<sub>2</sub>):  $\nu$ (C=O) 1897, 1968 cm<sup>-1</sup>. <sup>1</sup>H NMR (C<sub>3</sub>D<sub>6</sub>O, 300 MHz):  $\delta$  8.60 (d, <sup>3</sup>*J* = 4.8 Hz, 1H, Py), 8.08 (d, <sup>3</sup>*J* = 8.1 Hz, 1H, Py), 8.02 (dd, <sup>3</sup>*J* = 8.1 Hz, 1H, Py), 7.58 (dd, <sup>3</sup>*J* = 4.8 Hz, 1H, Py), 6.55 (d, <sup>3</sup>*J* = 6.6 Hz, 1H, ArCr), 6.08 (d, <sup>3</sup>*J* = 5.8 Hz, 1H, ArCr), 5.85 (m, <sup>3</sup>*J* = 6.6 Hz, <sup>3</sup>*J* = 5.8 Hz, 2H, ArCr). <sup>13</sup>C{<sup>1</sup>H} NMR (CDCl<sub>3</sub>, 125 MHz):  $\delta$  232.5 (CO), 153.6, 147.6, 138.3, 126.9, 124.4, 119.9, 106.3, 100.8, 93.6, 92.7, 91.1. <sup>199</sup>Hg NMR (CDCl<sub>3</sub>):  $\delta$  -886. MS (FAB+): *m/e* 619 [M]<sup>+</sup>, 563 [M - 2CO]<sup>+</sup>, 483 [M - Cr(CO)<sub>3</sub>]<sup>+</sup>.

**Direct Synthesis of (rel)-*u*- and *I*-Bis[tricarbonyl( $\eta^6$ -phenyl- $\kappa$ C<sup>1</sup>)chromium(0)]pyridine- $\kappa$ N]mercury(II) (**3**).** A mixture of **1** (200 mg, 0.68 mmol) and Hg(OAc)<sub>2</sub> (328 mg, 1.03 mmol) in EtOH (15 mL) was stirred at reflux over 3 h under argon. The resulting medium was cooled to room temperature and filtered through Celite. A small amount of yellow solid precipitated upon addition of a saturated solution of KI in EtOH. The mixture was vigorously stirred for 30 min and then filtered through Celite. The yellow filtrate was treated with H<sub>2</sub>O and the precipitate filtered off and dried under vacuum. Recrystallization from dry CH<sub>2</sub>Cl<sub>2</sub>/hexane afforded complex **3** (185 mg, 0.24 mmol, 69% yield). Spectroscopic and analytical data were identical with those published previously.

**Bis( $\mu$ -chloro)[2-(tricarbonyl( $\eta^6$ -phenyl- $\kappa$ C<sup>1</sup>)chromium(0)]pyridine- $\kappa$ N]palladium(II) (**4**; Mixture of Isomers).** A solution of PdCl<sub>2</sub>(MeCN)<sub>2</sub> (0.49 g, 1.90 mmol) in dry acetone (20 mL) was added dropwise to a solution of **2a** (1.00 g, 1.90 mmol) in acetone (60 mL) at -20 °C. The resulting mixture was vigorously stirred and slowly warmed to room temperature over 6 h. The solution was filtered through Celite and the solvent removed under reduced pressure. The crude residue was submitted to low-temperature (5 °C) flash chromatography over silica gel. Unreacted yellow complex **2a** was eluted with mixtures of 20% and 30% acetone in *n*-hexane, followed by one large orange-red fraction corresponding to a mixture of stereoisomers of **4** (0.67 g, 1.71 mmol, 90% yield), which was cleanly separated with a mixture of 50% acetone in hexane. Attempted separations of the four possible stereoisomers of **4** by a second flash chromatography at 5 °C over SiO<sub>2</sub> afforded only two fractions enriched in **4a** and **4b**, respectively, and a third fraction containing probably the two other swiftly interconverting isomers **4c** and **4d**. Data for the mixture of stereoisomers **4a–d** are as follows. Anal. Calcd for C<sub>28</sub>H<sub>16</sub>N<sub>2</sub>O<sub>6</sub>-Cl<sub>2</sub>Cr<sub>2</sub>Pd<sub>2</sub>: C, 38.88; H, 1.85; N, 3.24. Found: C, 38.73; H, 2.07; N, 2.99. IR (CH<sub>2</sub>Cl<sub>2</sub>)  $\nu$ (CO): 1893, 1968 cm<sup>-1</sup>. Complex **4a**: <sup>1</sup>H NMR (C<sub>3</sub>D<sub>6</sub>O, 500 MHz)  $\delta$  8.85 (d, <sup>3</sup>*J* = 4.8 Hz, 1H, Py), 8.14 (t, <sup>3</sup>*J* = 8.0 Hz, 1H, Py), 8.02 (d, <sup>3</sup>*J* = 7.9 Hz, 1H, Py), 7.58 (t, <sup>3</sup>*J* = 5.5 Hz, 1H, Py), 6.48 (d, <sup>3</sup>*J* = 6.6 Hz, 1H, ArCr), 6.08 (d, <sup>3</sup>*J* = 6.1 Hz, 1H, ArCr), 5.86 (t, <sup>3</sup>*J* = 6.4 Hz, 1H, ArCr), 5.59 (t, <sup>3</sup>*J* = 6.4 Hz, 1H, ArCr); <sup>13</sup>C{<sup>1</sup>H} NMR (C<sub>3</sub>D<sub>6</sub>O, 125 MHz):  $\delta$  235.6, 163.4, 149.9, 140.3, 128.5, 124.8, 120.1, 112.5, 101.4,

97.9, 93.4, 91.6. Complex **4b**: <sup>1</sup>H NMR (C<sub>3</sub>D<sub>6</sub>O, 500 MHz)  $\delta$  8.80 (d, <sup>3</sup>*J* = 4.9 Hz, 1H, Py), 8.09 (t, <sup>3</sup>*J* = 7.5 Hz, 1H, Py), 7.95 (d, <sup>3</sup>*J* = 8.2 Hz, 1H, Py), 7.54 (t, <sup>3</sup>*J* = 5.7 Hz, 1H, Py), 6.43 (d, <sup>3</sup>*J* = 5.7 Hz, 1H, ArCr), 5.92 (d, <sup>3</sup>*J* = 6.2 Hz, 1H, ArCr), 5.80 (t, <sup>3</sup>*J* = 6.2 Hz, 1H, ArCr), 5.50 (t, <sup>3</sup>*J* = 6.2 Hz, 1H, ArCr); <sup>13</sup>C{<sup>1</sup>H} NMR (C<sub>3</sub>D<sub>6</sub>O, 125 MHz)  $\delta$  235.1, 163.4, 149.7, 140.1, 127.2, 124.8, 120.1, 111.9, 100.7, 98.0, 93.4, 90.4. Complexes **4c, d**: <sup>1</sup>H NMR (C<sub>3</sub>D<sub>6</sub>O, 500 MHz)  $\delta$  8.63 (broad, 1H, Py), 8.12 (broad, 1H, Py), 7.88 (broad, 1H, Py), 7.46 (broad, 1H, Py), 6.26 (broad, 2H, ArCr), 5.62 (broad, 1H, ArCr), 5.48 (broad, 1H, ArCr).

**(rel)-*I* and *u*-(SP-4-4)-Bis[tricarbonyl( $\eta^6$ -phenyl- $\kappa$ C<sup>1</sup>)chromium(0)]pyridine- $\kappa$ N]palladium(II) (**6**).** A solution of Pd(MeCN)<sub>2</sub>Cl<sub>2</sub> (153 mg, 0.95 mmol) in dry acetone (10 mL) was added dropwise to a mixture of **2a** (1.0 g, 1.90 mmol) and [Me<sub>4</sub>N]Cl (2.08 g, 19.0 mmol) in acetone (40 mL) at -20 °C. The resulting mixture was vigorously stirred and slowly warmed to room temperature over 7 h. The brown-orange mixture was filtered through Celite and the filtrate stripped of solvents. The residue was separated by low-temperature (0 °C) flash chromatography over silica gel. The unreacted complexes **2a** and **3** were eluted first with 20% and 30% acetone/hexane mixtures. Then, the two diastereoisomers of **6** were separated with 40% and 50% acetone/hexane mixtures; the orange-beige fraction corresponding to (rel)-*I*-**6** (35 mg) was eluted and followed by the fraction identified as being *u*-**6** (180 mg). Complex **6**: *dr* = 1:5 ((rel)-*I*:*u*), 215 mg, 0.313 mmol, 33% conversion. Complex (rel)-*I*-**6**: HRMS calcd for C<sub>28</sub>H<sub>16</sub>N<sub>2</sub>O<sub>6</sub><sup>52</sup>-Cr<sub>2</sub><sup>105</sup>Pd 684.8869, found: 684.8902; IR (CH<sub>2</sub>Cl<sub>2</sub>)  $\nu$ (C=O) 1881, 1953 cm<sup>-1</sup>; <sup>1</sup>H NMR (C<sub>3</sub>D<sub>6</sub>O, 500 MHz)  $\delta$  8.86 (d, <sup>3</sup>*J* = 5.1 Hz, 2H, Py), 8.14 (t, <sup>3</sup>*J* = 7.6 Hz, 2H, Py), 8.05 (d, <sup>3</sup>*J* = 7.8 Hz, 2H, Py), 7.60 (t, <sup>3</sup>*J* = 6.4 Hz, 2H, Py), 6.52 (d, <sup>3</sup>*J* = 6.5 Hz, 2H, ArCr), 6.08 (d, <sup>3</sup>*J* = 6.3 Hz, 2H, ArCr), 5.89 (t, <sup>3</sup>*J* = 6.6 Hz, 2H, ArCr), 5.60 (t, <sup>3</sup>*J* = 6.4 Hz, 2H, ArCr); <sup>13</sup>C{<sup>1</sup>H} NMR (C<sub>3</sub>D<sub>6</sub>O, 125 MHz)  $\delta$  235.6 (CO), 163.3, 149.8, 140.3, 128.7, 124.8, 120.1, 112.5, 101.3, 98.0, 93.4, 91.5; MS (FAB+) *m/e* 686 [M]<sup>+</sup>, 602 [M - 3CO]<sup>+</sup>, 550 [M - Cr(CO)<sub>3</sub>]<sup>+</sup>. Complex *u*-**6**: HRMS calcd for C<sub>28</sub>H<sub>16</sub>N<sub>2</sub>O<sub>6</sub><sup>52</sup>-Cr<sub>2</sub><sup>105</sup>Pd 684.8869, found 684.8903; IR (CH<sub>2</sub>Cl<sub>2</sub>)  $\nu$ (C=O) 1879, 1965 cm<sup>-1</sup>; <sup>1</sup>H NMR (C<sub>3</sub>D<sub>6</sub>O, 500 MHz)  $\delta$  8.75 (d, <sup>3</sup>*J* = 5.1 Hz, 2H, Py), 8.06 (t, <sup>3</sup>*J* = 7.8 Hz, 2H, Py), 7.91 (d, <sup>3</sup>*J* = 8.1 Hz, 2H, Py), 7.51 (t, <sup>3</sup>*J* = 6.3 Hz, 2H, Py), 6.38 (d, <sup>3</sup>*J* = 6.4 Hz, 2H, ArCr), 5.88 (d, <sup>3</sup>*J* = 6.4 Hz, 2H, ArCr), 5.76 (t, <sup>3</sup>*J* = 6.2 Hz, 2H, ArCr), 5.46 (t, <sup>3</sup>*J* = 6.3 Hz, 2H, ArCr); <sup>13</sup>C{<sup>1</sup>H} NMR (C<sub>3</sub>D<sub>6</sub>O, 125 MHz)  $\delta$  235.1 (CO), 163.4, 149.7, 140.0, 127.4, 124.7, 120.1, 111.9, 100.7, 98.0, 93.4, 90.4; MS (FAB+) *m/e* 686 [M]<sup>+</sup>, 602 [M - 3CO]<sup>+</sup>, 550 [M - Cr(CO)<sub>3</sub>]<sup>+</sup>. Anal. Calcd for C<sub>28</sub>H<sub>16</sub>N<sub>2</sub>O<sub>6</sub>Cr<sub>2</sub>Pd·CH<sub>2</sub>Cl<sub>2</sub>: C, 45.14; H, 2.33; N, 3.63. Found: C, 44.78; H, 2.36; N, 3.54.

**Alternative Method for the Synthesis of **6** from **8a**.** A solution of **8a** (100 mg, 0.18 mmol) and **2a** (116 mg, 0.22 mmol) in acetone (10 mL) was stirred at room temperature for 14 h. The mixture was filtered over Celite and the solvent evaporated under vacuum. Low-temperature (0 °C) flash chromatography over silica gel delivered first the byproduct **9a** and the unreacted product **2a** (yellow fraction) with 20% and 30% acetone in hexane mixtures. A large orange fraction corresponding to **6** (*dr* = 1:10 ((rel)-*I*:*u*), 65 mg, 0.095 mmol, 50% conversion) was eluted with 40% and 50% acetone in hexane mixtures.

**rac-(SP-4-4)-[2-(tricarbonyl( $\eta^6$ -phenyl- $\kappa$ C<sup>1</sup>)chromium(0)]pyridine- $\kappa$ N]-(*N,N*-dimethylbenzylamine- $\kappa$ C<sup>1</sup>,*N*)-palladium(II) (**8a**).** A solution of **7a** (460 mg, 0.79 mmol) in dry acetone (20 mL) was added dropwise to a mixture of **2a** (830 mg, 1.58 mmol) and [Me<sub>4</sub>N]Cl (1.73 g, 15.8 mmol) in acetone (40 mL) at -20 °C. The resulting mixture was vigorously stirred and slowly warmed to room temperature over 7 h. Then, the mixture was filtered through Celite to remove [Me<sub>4</sub>N]<sub>2</sub>[Hg<sub>2</sub>Cl<sub>6</sub>] and the remaining [Me<sub>4</sub>N]Cl. The filtrate was stripped of solvents. The residue was separated by low-temperature (5 °C) flash chromatography over silica gel, and the starting chloromercurated compound **2a** was eluted

(45) Fair, C. K. In *MolEN: An Interactive Intelligent System for Crystal Structure Analysis*; Nonius: Delft, The Netherlands, 1990.

with a mixture of 20% acetone in hexane. The orange-brown product **8a** (520 mg, 0.98 mmol, 62% yield) was eluted with a mixture of 50% acetone in hexane. Complex **8a**: IR (CH<sub>2</sub>Cl<sub>2</sub>)  $\nu(\text{CO})$  1951, 1875 cm<sup>-1</sup>; <sup>1</sup>H NMR (CDCl<sub>3</sub>, 500 MHz)  $\delta$  8.41 (d, <sup>3</sup>J = 5.4 Hz, 1H, Py), 7.84 (t, <sup>3</sup>J = 7.6 Hz, 1H, Py), 7.64 (d, <sup>3</sup>J = 7.4 Hz, 1H, Ph), 7.58 (d, <sup>3</sup>J = 8.0 Hz, 1H, Py), 7.26 (t, <sup>3</sup>J = 4.2 Hz, 1H, Py), 7.12 (m, 1H, Ph), 7.04 (m, 2H, Ph), 5.99 (d, <sup>3</sup>J = 6.5 Hz, 1H, ArCr), 5.89 (d, <sup>3</sup>J = 6.4 Hz, 1H, ArCr), 5.62 (t, <sup>3</sup>J = 6.4 Hz, 1H, ArCr), 5.17 (t, <sup>3</sup>J = 6.4 Hz, 1H, ArCr), 4.35 (d, <sup>2</sup>J = 12.8 Hz, 1H, CH<sub>2</sub>), 3.54 (d, <sup>2</sup>J = 12.8 Hz, 1H, CH<sub>2</sub>), 2.86 (s, 3H, NMe<sub>2</sub>), 2.57 (s, 3H, NMe<sub>2</sub>); <sup>13</sup>C{<sup>1</sup>H} NMR (CDCl<sub>3</sub>, 125 MHz)  $\delta$  234.7 (CO), 162.7, 157.6, 147.8, 147.6, 138.5, 137.4, 130.0, 126.5, 123.8, 122.6, 122.1, 118.4, 109.1, 101.4, 97.7, 92.4, 88.4, 73.0, 50.1, 49.1. Anal. Calcd for C<sub>23</sub>H<sub>20</sub>N<sub>2</sub>O<sub>3</sub>CrPd: C, 52.07; H, 3.77; N, 5.28. Found: C, 51.57; H, 3.69; N, 5.08.

**(SP-4-4)-[2-(Tricarbonyl( $\eta^6$ -phenyl- $\kappa$ C')chromium(0))-pyridine- $\kappa$ N][2-(phenyl- $\kappa$ C')-pyridine- $\kappa$ N]palladium(II) (**8b**). The procedure for this reaction was similar to that described for **8a**. The conditions were slightly changed as follows: **7b** (190 mg, 0.32 mmol) in dry acetone (20 mL) was added dropwise to a mixture of **2a** (337 mg, 0.64 mmol) and [Me<sub>4</sub>N]Cl (703 mg, 6.42 mmol) in acetone (40 mL) at -20 °C. Low-temperature (5 °C) flash chromatography over silica gel delivered first the byproducts upon elution with mixtures of 10% and 20% acetone in hexane. The large orange fraction corresponding to **8b** (178 mg, 0.32 mmol, 50% yield) was eluted with a mixture of 30% acetone in hexane. Complex **8b**: IR (CH<sub>2</sub>Cl<sub>2</sub>)  $\nu(\text{C}=\text{O})$  1879, 1953 cm<sup>-1</sup>; <sup>1</sup>H NMR (C<sub>3</sub>D<sub>6</sub>O, 500 MHz)  $\delta$  8.89 (d, <sup>3</sup>J = 5.2 Hz, 1H, Py), 8.79 (d, <sup>3</sup>J = 5.3 Hz, 1H, Py), 8.11 (t, <sup>3</sup>J = 7.7 Hz, 2H), 8.07 (d, <sup>3</sup>J = 8.5 Hz, 1H), 7.99 (d, <sup>3</sup>J = 8.1 Hz, 1H), 7.87 (d, <sup>3</sup>J = 7.6 Hz, 1H), 7.76 (d, <sup>3</sup>J = 7.6 Hz, 1H), 7.55 (t, <sup>3</sup>J = 6.3 Hz, 1H), 7.47 (t, <sup>3</sup>J = 5.7 Hz, 1H), 7.23 (t, <sup>3</sup>J = 7.4 Hz, 1H), 7.13 (t, <sup>3</sup>J = 7.9 Hz, 1H), 6.45 (d, <sup>3</sup>J = 6.3 Hz, 1H, ArCr), 6.11 (d, <sup>3</sup>J = 6.3 Hz, 1H, ArCr), 5.84 (t, <sup>3</sup>J = 6.3 Hz, 1H, ArCr), 5.55 (t, <sup>3</sup>J = 6.3 Hz, 1H, ArCr); <sup>13</sup>C{<sup>1</sup>H} NMR (C<sub>3</sub>D<sub>6</sub>O, 125 MHz)  $\delta$  235.9 (CO), 165.7, 163.3, 161.8, 149.9, 149.6, 147.7, 139.9, 139.8, 138.0, 130.2, 129.4, 124.8, 124.6, 124.4, 123.6, 120.1, 120.0, 112.8, 102.5, 98.1, 93.5, 91.2. Anal. Calcd for C<sub>25</sub>H<sub>16</sub>N<sub>2</sub>O<sub>3</sub>CrPd: C, 54.54; H, 2.90; N, 5.09. Found: C, 54.64; H, 3.11; N, 4.87.**

**(rel)-I- and u-(SP-4-4)-[Tricarbonyl( $\eta^6$ -N,N-dimethylbenzylamine- $\kappa$ C',N)chromium(0)][2-(tricarbo-nyl( $\eta^6$ -phenyl- $\kappa$ C')chromium(0))pyridine- $\kappa$ N]palladium(II) (**8c**). A solution of **8a** (200 mg, 0.37 mmol) and **9b** (225 mg, 0.44 mmol) in acetone (10 mL) was stirred at room temperature for 7 h. The mixture was filtered through Celite and the filtrate stripped from solvent under vacuum. Low-temperature (5 °C) flash chromatography over silica gel afforded first the byproduct **9a** (colorless fraction) and some amounts of unreacted product **9b** upon elution with mixtures of 30% and 40% acetone in hexane. A large orange fraction corresponding to a mixture of the two stereoisomers of **8c** (*rel*-*l*-*u* dr = 1:1.7, 133 mg, 0.19 mmol, 52% conversion) was eluted with a mixture of 50–60% acetone in hexane. Diastereoisomers *rac*-*l*-**8c** and *u*-**8c** (133 mg) were separated by low-temperature (0 °C) flash chromatography over silica gel using mixtures of 60% and 80% of CH<sub>2</sub>Cl<sub>2</sub> in hexane, respectively. The first orange band of (*rel*)-**8c** (20 mg) was followed by the orange fraction of *u*-**8c** (25 mg). Mixture of diastereoisomers **8c**: Anal. Calcd for C<sub>26</sub>H<sub>20</sub>N<sub>2</sub>O<sub>6</sub>Cr<sub>2</sub>Pd: C, 46.85; H, 3.00; N, 4.20. Found: C, 46.45; H, 2.85; N, 4.05. Complex (*rel*)-**8c**: IR (CH<sub>2</sub>Cl<sub>2</sub>)  $\nu(\text{C}=\text{O})$  1875, 1950 cm<sup>-1</sup>; <sup>1</sup>H NMR (C<sub>3</sub>D<sub>6</sub>O, 500 MHz)  $\delta$  8.72 (d, <sup>3</sup>J = 5.1 Hz, 1H, Py), 8.10 (t, <sup>3</sup>J = 8.1 Hz, 1H, Py), 7.97 (d, <sup>3</sup>J = 8.1 Hz, 1H, Py), 7.53 (t, <sup>3</sup>J = 6.1 Hz, 1H, Py), 6.47 (d, <sup>3</sup>J = 6.2 Hz, 1H, ArCr), 6.05 (d, <sup>3</sup>J = 6.4 Hz, 1H, ArCr), 5.82 (t, <sup>3</sup>J = 6.2 Hz, 1H, ArCr), 5.77 (d, <sup>3</sup>J = 6.4 Hz, 1H, ArCr), 5.69 (d, <sup>3</sup>J = 6.1 Hz, 1H, ArCr), 5.64 (t, <sup>3</sup>J = 6.2 Hz, 1H, ArCr), 5.54 (t, <sup>3</sup>J = 6.2 Hz, 1H, ArCr), 5.40 (t, <sup>3</sup>J = 6.1 Hz, 1H, ArCr), 3.94 (d, <sup>2</sup>J = 13.9 Hz, 2H, CH<sub>2</sub>), 3.64 (d, <sup>2</sup>J = 13.9 Hz, 2H, CH<sub>2</sub>), 3.07 (s, 3H, NMe<sub>3</sub>), 2.77 (s, 3H, NMe<sub>3</sub>); <sup>13</sup>C{<sup>1</sup>H} NMR (C<sub>3</sub>D<sub>6</sub>O, 125 MHz)  $\delta$  236.5 and 235.6**

(CO's), 162.8, 149.6, 140.3, 128.0, 125.3, 124.8, 120.1, 112.3, 102.8, 100.9, 98.3, 96.7, 94.5, 93.5, 90.8, 90.6, 71.1, 49.8, 49.2. Anal. Calcd for C<sub>26</sub>H<sub>20</sub>N<sub>2</sub>O<sub>6</sub>Cr<sub>2</sub>Pd: C, 46.85; H, 3.00; N, 4.20. Found: C, 47.07; H, 2.89; N, 4.10. Complex (*rel*)-**8c**: HRMS calcd for C<sub>26</sub>H<sub>20</sub>N<sub>2</sub>O<sub>6</sub><sup>52</sup>Cr<sub>2</sub><sup>104</sup>Pd 663.9172, found 663.9188; IR (CH<sub>2</sub>Cl<sub>2</sub>)  $\nu(\text{C}=\text{O})$  1866, 1963 cm<sup>-1</sup>; <sup>1</sup>H NMR (C<sub>3</sub>D<sub>6</sub>O, 500 MHz)  $\delta$  8.75 (d, <sup>3</sup>J = 5.2 Hz, 1H, Py), 8.06 (t, <sup>3</sup>J = 7.2 Hz, 1H, Py), 7.96 (d, <sup>3</sup>J = 8.1 Hz, 1H, Py), 7.47 (t, <sup>3</sup>J = 6.4 Hz, 1H, Py), 6.44 (d, <sup>3</sup>J = 6.2 Hz, 1H, ArCr), 6.21 (d, <sup>3</sup>J = 6.1 Hz, 1H, ArCr), 5.78 (t, <sup>3</sup>J = 6.1 Hz, 1H, ArCr), 5.67 (d, <sup>3</sup>J = 5.7 Hz, 1H, ArCr), 5.58 (d, <sup>3</sup>J = 4.9 Hz, 1H, ArCr), 5.44 (t, <sup>3</sup>J = 6.4 Hz, 2H, ArCr), 5.39 (t, <sup>3</sup>J = 6.1 Hz, 1H, ArCr), 4.23 (d, <sup>2</sup>J = 13.1 Hz, 2H, CH<sub>2</sub>), 3.30 (d, <sup>2</sup>J = 13.3 Hz, 2H, CH<sub>2</sub>), 3.01 (s, 3H, NMe<sub>3</sub>), 2.64 (s, 3H, NMe<sub>3</sub>); <sup>13</sup>C{<sup>1</sup>H} NMR (C<sub>3</sub>D<sub>6</sub>O, 125 MHz)  $\delta$  236.3 (CO), 235.3 (CO), 163.3, 149.6, 140.2, 129.0, 127.0, 124.2, 120.9, 119.5, 110.2, 105.5, 99.5, 98.5, 95.3, 93.1, 92.0, 91.1, 90.0, 71.2, 50.0, 48.0; MS (FAB+) *m/e* 666 [M]<sup>+</sup>, 582 [M - 3CO]<sup>+</sup>, 530 [M - Cr(CO)<sub>3</sub>]<sup>+</sup>.

**I- and u-(SP-4-4)-(7R)-[Tricarbonyl( $\eta^6$ -7-methyl-N,N-dimethylbenzylamine- $\kappa$ C',N)chromium(0)][2-(tricarbo-nyl( $\eta^6$ -phenyl- $\kappa$ C')chromium(0))pyridine]palladium(II) (**8d**). The procedure for this reaction was similar to that described for **8c**. The conditions were slightly changed as follows: **8a** (700 mg, 1.32 mmol) and (*7R*)-**9c** (726 mg, 1.45 mmol) solution in acetone (10 mL) at room temperature for 16 h. Low-temperature (0 °C) chromatography over silica gel carried out with a mixture of 60% CH<sub>2</sub>Cl<sub>2</sub> in hexane delivered first colorless (*7R*)-**7c** and unreacted (*7R*)-**9c**. The large orange fraction corresponding to the two stereoisomers of **8d** (*l*-*u* dr = 1:1.5, 280 mg, 0.41 mmol, 31% conversion) was eluted with a mixture of 60% and 70% CH<sub>2</sub>Cl<sub>2</sub> in hexane. The two diastereoisomers (*7R*)-**8d** and (*7R*)-**u**-**8d** (280 mg) were separated by low-temperature (0 °C) flash chromatography over silica gel with mixtures of CH<sub>2</sub>Cl<sub>2</sub> in hexane ranging from 50% up to 80%. The orange fraction corresponding to (*7R*)-**8d** (40 mg) was first eluted, followed by (*7R*)-**u**-**8d** (60 mg). Complex (*7R*)-**8d**: [ $\alpha$ ]<sub>D</sub> (CH<sub>2</sub>Cl<sub>2</sub>, 25 °C) -1100° (*c* = 0.04 g/100 mL); IR (CH<sub>2</sub>Cl<sub>2</sub>)  $\nu(\text{C}=\text{O})$  1874, 1950 cm<sup>-1</sup>; <sup>1</sup>H NMR (C<sub>3</sub>D<sub>6</sub>O, 300 MHz)  $\delta$  8.76 (d, <sup>3</sup>J = 5.2 Hz, 1H, py), 8.09 (t, <sup>3</sup>J = 7.8 Hz, 1H, py), 7.96 (d, <sup>3</sup>J = 8.1 Hz, 1H, py), 7.53 (t, <sup>3</sup>J = 6.2 Hz, 1H, py), 6.43 (d, <sup>3</sup>J = 6.3 Hz, 1H, ArCr), 6.13 (d, <sup>3</sup>J = 6.3 Hz, 1H, ArCr), 5.79 (d, <sup>3</sup>J = 5.1 Hz, 2H, ArCr), 5.65 (t, <sup>3</sup>J = 6.1 Hz, 2H, ArCr), 5.55 (t, <sup>3</sup>J = 6.1 Hz, 1H, ArCr), 5.37 (t, <sup>3</sup>J = 6.2 Hz, 1H, ArCr), 4.08 (q, <sup>3</sup>J = 6.7 Hz, 1H, CH), 3.17 (s, 3H, NMe<sub>3</sub>), 2.62 (s, 3H, NMe<sub>3</sub>), 1.48 (d, <sup>3</sup>J = 6.7 Hz, 3H, CH<sub>3</sub>); <sup>13</sup>C{<sup>1</sup>H} NMR (C<sub>3</sub>D<sub>6</sub>O, 125 MHz)  $\delta$  236.4 (CO), 235.7 (CO), 162.8, 149.5, 140.2, 129.5, 125.6, 124.9, 124.7, 120.2, 112.5, 102.6, 101.2, 98.0, 97.4, 94.3, 93.6, 90.9, 90.4, 71.8, 48.3, 42.4, 13.7. Anal. Calcd for C<sub>27</sub>H<sub>22</sub>N<sub>2</sub>O<sub>6</sub>Cr<sub>2</sub>Pd: C, 47.65; H, 3.23; N, 4.12. Found: C, 47.93; H, 2.91; N, 4.08. Complex (*7R*)-**u**-**8d**: [ $\alpha$ ]<sub>D</sub> (CH<sub>2</sub>Cl<sub>2</sub>, 25 °C) +550° (*c* = 0.04 g/100 mL); IR (CH<sub>2</sub>Cl<sub>2</sub>)  $\nu(\text{C}=\text{O})$  1867, 1962 cm<sup>-1</sup>; <sup>1</sup>H NMR (C<sub>3</sub>D<sub>6</sub>O, 300 MHz)  $\delta$  8.78 (d, <sup>3</sup>J = 5.1 Hz, 1H, py), 8.06 (dd, <sup>3</sup>J = 7.8 Hz, 1H, py), 7.95 (d, <sup>3</sup>J = 7.8 Hz, 1H, py), 7.48 (dd, <sup>3</sup>J = 6.5 Hz, 1H, py), 6.42 (d, <sup>3</sup>J = 6.0 Hz, 1H, ArCr), 6.28 (d, <sup>3</sup>J = 5.8 Hz, 1H, ArCr), 5.79 (dd, <sup>3</sup>J = 6.2 Hz, 1H, ArCr), 5.63 (d, <sup>3</sup>J = 6.2 Hz, 1H, ArCr), 5.44 (m, 3H, ArCr), 5.36 (dd, <sup>3</sup>J = 6.0 Hz, 1H, ArCr), 4.41 (q, <sup>3</sup>J = 6.8 Hz, 1H, CH), 3.11 (s, 3H, NMe<sub>2</sub>), 2.47 (s, 3H, NMe<sub>2</sub>), 1.32 (d, <sup>3</sup>J = 6.8 Hz, 3H, CH<sub>3</sub>); <sup>13</sup>C{<sup>1</sup>H} NMR (C<sub>3</sub>D<sub>6</sub>O, 125 MHz)  $\delta$  236.1 (CO), 235.3 (CO), 163.2, 149.4, 140.2, 130.7, 129.3, 124.3, 124.1, 119.5, 109.9, 105.5, 99.3, 99.0, 96.2, 93.4, 92.0, 90.8, 89.7, 70.6, 46.8, 40.5, 8.0. Anal. Calcd for C<sub>27</sub>H<sub>22</sub>N<sub>2</sub>O<sub>6</sub>Cr<sub>2</sub>Pd: C, 47.65; H, 3.23; N, 4.12. Found: C, 47.94; H, 3.06; N, 3.96.**

**exo- and endo-(SP-4-4)-(7S)-(7-Methyl-N,N-dimethylbenzylamine- $\kappa$ C',N)[2-(tricarbo-nyl( $\eta^6$ -phenyl)chromium(0))pyridine]palladium(II) ((*7S*)-**8e**). A solution of (*7S*)-**7c** (860 mg, 1.48 mmol) in dry acetone (20 mL) was added dropwise to a mixture of **2a** (1.56 g, 2.96 mmol) and [Me<sub>4</sub>N]Cl (3.2 g, 29.6 mmol) in acetone (60 mL) at -20 °C. The reaction medium was vigorously stirred and slowly warmed to room temperature over 7 h. The resulting mixture was filtered over**



Celite and the solvent evaporated under reduced pressure. Low-temperature (5 °C) chromatography over silica gel using mixtures of 20% and 50% of acetone in hexane afforded the unreacted chloromercurated compound **2a** and an orange fraction corresponding to a mixture of diastereoisomers (7*S*)-**8e** (*endo:exo* dr = 1.3:1, 1.14 g, 2.09 mmol, 70% conversion), respectively. The two diastereoisomers (7*S*)-*endo*- and *exo*-**8e** (400 mg) were separated by low-temperature (0 °C) chromatography (column: 40 cm length × 3 cm diameter) over silica gel with dry CH<sub>2</sub>Cl<sub>2</sub>. The orange-red fraction corresponding to (+)-(*pR*,7*S*)-*endo*-**8e** (83 mg) was eluted first, followed by a mixture of (*pS*,7*S*)-*exo*-**8e** and the products of decomposition identified as **1** and (7*S*)-**7c**. Unfortunately, (*pS*,7*S*)-*exo*-**8e** could not be obtained completely free of impurities, mostly because of its air sensitivity. NMR spectroscopic data were deduced by difference from the spectra of the mixture of (7*S*)-*endo*- and *exo*-**8e** and pure (*pR*,7*S*)-*endo*-**8e**. Mixture of diastereoisomers (7*S*)-**8e**: Anal. Calcd for C<sub>24</sub>H<sub>22</sub>N<sub>2</sub>O<sub>3</sub>CrPd: C, 52.89; H, 4.04; N, 5.14. Found: C, 52.96; H, 4.02; N, 5.04. (+)-(*pR*,7*S*)-*endo*-**8e**: [ $\alpha$ ]<sub>D</sub> (CH<sub>2</sub>Cl<sub>2</sub>, 298 K) = +788° (*c* = 0.04 g/100 mL); IR (CH<sub>2</sub>Cl<sub>2</sub>)  $\nu$ (CO) 1951, 1875 cm<sup>-1</sup>; <sup>1</sup>H NMR (CDCl<sub>3</sub>, 300 MHz)  $\delta$  8.48 (d, <sup>3</sup>*J* = 5.1 Hz, 1H, Py), 7.83 (t, <sup>3</sup>*J* = 7.5 Hz, 1H, Py), 7.61 (d, <sup>3</sup>*J* = 7.4 Hz, 1H, Ph), 7.58 (d, <sup>3</sup>*J* = 8.1 Hz, 1H, Py), 7.26 (t, <sup>3</sup>*J* = 6.0, 1H, Py), 7.09 (m, 1H, Ph), 7.03 (m, 2H, Ph), 5.95 (d, <sup>3</sup>*J* = 6.5 Hz, 2H, ArCr), 5.57 (t, <sup>3</sup>*J* = 6.2 Hz, 1H, ArCr), 5.24 (t, <sup>3</sup>*J* = 6.2 Hz, 1H, ArCr), 3.47 (q, <sup>3</sup>*J* = 7.0 Hz, 1H, CH), 2.83 (s, 3H, NMe<sub>2</sub>), 2.54 (s, 3H, NMe<sub>2</sub>), 1.92 (d, <sup>3</sup>*J* = 6.4 Hz, 3H, CH<sub>3</sub>); <sup>13</sup>C{<sup>1</sup>H} NMR (CDCl<sub>3</sub>, 125 MHz)  $\delta$  234.7 (CO), 162.7, 155.5, 154.1, 147.7, 138.2, 137.7, 130.4, 126.0, 123.6, 122.4, 121.4, 118.2, 109.2, 101.9, 96.6, 91.0, 89.4, 76.4, 50.9, 46.8, 23.7; UV-vis (CH<sub>2</sub>Cl<sub>2</sub>)  $\lambda$  275 (1.6 × 10<sup>5</sup>), 436 nm (3.3 × 10<sup>4</sup>); CD (MeOH, 20 °C):  $\lambda$  275 (11.1), 281 (11.6), 325 (-14.4), 378 (3.9), 435 (5.75) nm. Anal. Calcd for C<sub>24</sub>H<sub>22</sub>N<sub>2</sub>O<sub>3</sub>CrPd: C, 52.89; H, 4.04; N, 5.14. Found: C, 52.82; H, 4.33; N, 4.89. (*pS*,7*S*)-*exo*-**8e**: IR (CH<sub>2</sub>Cl<sub>2</sub>)  $\nu$ (CO) 1951, 1875 cm<sup>-1</sup>; <sup>1</sup>H NMR (CDCl<sub>3</sub>, 300 MHz)  $\delta$  8.45 (d, <sup>3</sup>*J* = 5.2 Hz, 1H, Py), 7.83 (t, <sup>3</sup>*J* = 7.2 Hz, 1H, Py), 7.66 (d, <sup>3</sup>*J* = 7.2 Hz, 1H, Ph), 7.58 (d, <sup>3</sup>*J* = 8.1 Hz, 1H, py), 7.26 (t, 1H, py), 7.14 (t, <sup>3</sup>*J* = 7.2 Hz, 1H, Ph), 7.06 (t, <sup>3</sup>*J* = 7.2 Hz, 1H, Ph), 6.93 (d, <sup>3</sup>*J* = 7.3 Hz, 1H, Ph), 5.97 (d, <sup>3</sup>*J* = 6.5 Hz, 1H, ArCr), 5.88 (d, <sup>3</sup>*J* = 6.3 Hz, 1H, ArCr), 5.60 (t, <sup>3</sup>*J* = 6.3 Hz, 1H, ArCr), 5.18 (t, <sup>3</sup>*J* = 6.2 Hz, 1H, ArCr), 4.26 (q, <sup>3</sup>*J* = 6.5 Hz, 1H, CH), 2.89 (s, 3H, NMe<sub>2</sub>), 2.47 (s, 3H, NMe<sub>2</sub>), 1.55 (d, <sup>3</sup>*J* = 6.5 Hz, 3H, CH<sub>3</sub>); <sup>13</sup>C{<sup>1</sup>H} NMR (CDCl<sub>3</sub>)  $\delta$  234.6 (CO), 162.4, 158.5, 151.8, 147.5, 138.2, 137.1, 130.4, 126.4, 123.4, 122.5, 121.8, 118.3, 109.2, 101.7, 97.5, 92.3, 88.1, 72.4, 47.9, 42.9, 23.6.

**exo- and endo-(SP-4-4)-(7R)-(7-Methyl-N,N-dimethylbenzylamine- $\kappa$  C<sup>1</sup>,N)[2-{tricarboxyl( $\eta^6$ -phenyl- $\kappa$  C<sup>1</sup>)-chromium(0)}pyridine- $\kappa$ N]palladium(II) ((7R)-**8e**).** The procedure for this reaction was similar to that described previously for (7*R*)-**8e**, as follows: (7*R*)-**7c** (550 mg, 0.95 mmol) solution in acetone (20 mL), mixture of **2a** (1.0 g, 1.90 mmol) and [Me<sub>4</sub>N]Cl (2.1 g, 19 mmol) in acetone (60 mL) at -20 °C. Low-temperature (5 °C) chromatography over silica gel with a mixture of 20% and 50% acetone in hexane delivered a raw mixture of the two diastereoisomers (7*R*)-**8e** (dr = 1.3:1 (*endo:exo*), 670 mg, 1.23 mmol, 65% conversion), which were separated by a second flash chromatography. A pure sample of complex (7*R*)-**8e** (74 mg) was obtained from a mixture of (7*R*)-*endo*- and *exo*-**8e** (300 mg). The NMR spectroscopic data of (*pR*,7*R*)-*exo*-**8e** were identical with those observed for (*pS*,7*S*)-*exo*-**8e** and were deduced by difference between the NMR spectra of the mixture of (7*R*)-*endo*- and *exo*-**8e** and pure (*pS*,7*R*)-*endo*-**8e**. Mixture of the two stereoisomers: Anal. Calcd for C<sub>24</sub>H<sub>22</sub>N<sub>2</sub>O<sub>3</sub>CrPd: C, 52.89; H, 4.04; N, 5.14. Found: C, 53.03; H, 3.81; N, 5.00. (-)-(*pS*,7*R*)-*endo*-**8e**: [ $\alpha$ ]<sub>D</sub> (CH<sub>2</sub>Cl<sub>2</sub>, 298 K) -813° (*c* = 0.04 g/100 mL); IR (CH<sub>2</sub>Cl<sub>2</sub>)  $\nu$ (CO) 1951, 1875 cm<sup>-1</sup>; <sup>1</sup>H NMR (CDCl<sub>3</sub>, 300 MHz)  $\delta$  8.48 (d, <sup>3</sup>*J* = 5.0 Hz, 1H, py), 7.83 (t, <sup>3</sup>*J* = 7.5 Hz, 1H, py), 7.61 (d, <sup>3</sup>*J* = 7.4 Hz, 1H, Ph), 7.58 (d, <sup>3</sup>*J* = 8.1 Hz, 1H, py), 7.26 (t, 1H, py), 7.09 (m, 1H, Ph), 7.03 (m, 2H, Ph), 5.94 (d, <sup>3</sup>*J* = 6.3 Hz, 2H, ArCr),

5.57 (t, <sup>3</sup>*J* = 6.1 Hz, 1H, ArCr), 5.24 (t, <sup>3</sup>*J* = 6.2 Hz, 1H, ArCr), 3.47 (q, <sup>3</sup>*J* = 6.6 Hz, 1H, CH), 2.83 (s, 3H, NMe<sub>2</sub>), 2.54 (s, 3H, NMe<sub>2</sub>), 1.92 (d, <sup>3</sup>*J* = 6.5 Hz, 3H, CH<sub>3</sub>); <sup>13</sup>C{<sup>1</sup>H} NMR (CDCl<sub>3</sub>, 125 MHz)  $\delta$  234.7 (CO), 162.7, 155.5, 154.1, 147.7, 138.2, 137.7, 130.4, 126.0, 123.6, 122.4, 121.4, 118.2, 109.2, 101.9, 96.6, 91.0, 89.4, 76.4, 50.9, 46.8, 23.7; CD (MeOH, 20 °C):  $\lambda$  275 (-10.2), 281 (-10.6), 324 (13.3), 380 (-3.6), 435 nm (-5.3). Anal. Calcd for C<sub>24</sub>H<sub>22</sub>N<sub>2</sub>O<sub>3</sub>CrPd: C, 52.89; H, 4.04; N, 5.14. Found: C, 52.59; H, 4.24; N, 4.86.

**(+)-(pR)-(SP-4-4)-Chloro(pyridine)[2'-(tricarboxyl( $\eta^6$ -phenyl- $\kappa$  C<sup>1</sup>)-chromium(0)}pyridine- $\kappa$ N]palladium(II) ((+)-**5**).** A mixture of (*pR*,7*S*)-*endo*-**8e** (80 mg, 0.15 mmol) and HgCl<sub>2</sub> (60 mg, 0.22 mmol) in dry acetone (20 mL) was stirred at room temperature for 14 h. An excess of pyridine was added dropwise, and the resulting mixture was stirred for an additional 15 min and then filtered through Celite. The filtrate was stripped of solvents. The product was purified by low-temperature (0 °C) flash chromatography over silica gel. The colorless (7*S*)-**9d** byproduct was eluted with a 10% acetone in hexane mixture, followed by the orange product (+)-(*pR*)-**5** (50 mg, 0.098 mmol, 65% yield), which was cleanly eluted with a 40% acetone in hexane mixture. The spectroscopic data of this complex were in agreement with those published for the racemate. (+)-(*pR*)-**5**: [ $\alpha$ ]<sub>D</sub> (CH<sub>2</sub>Cl<sub>2</sub>, 298 K) +751° (*c* = 0.04 g/100 mL); UV-vis (CH<sub>2</sub>Cl<sub>2</sub>, 20 °C)  $\lambda$  271 (1.26 × 10<sup>6</sup> mol<sup>-1</sup> dm<sup>2</sup>), 315 (9.1 × 10<sup>4</sup>), 444 nm (3.3 × 10<sup>4</sup>); CD (MeOH, 20 °C)  $\lambda$  246 (-8.5), 268 (+4.6), 326 (-10.0), 445 nm (+6.2). Anal. Calcd for C<sub>19</sub>H<sub>13</sub>N<sub>2</sub>O<sub>3</sub>ClCrPd: C, 44.62; H, 2.54; N, 5.48. Found: C, 44.45; H, 2.51; N, 5.38.

**(-)-(pS)-(SP-4-4)-Chloro(pyridine)[2'-(tricarboxyl( $\eta^6$ -phenyl- $\kappa$  C<sup>1</sup>)-chromium(0)}pyridine- $\kappa$ N]palladium(II) ((-)-**5**).** The procedure was similar to that described for (+)-**5**: (*pS*,7*R*)-*endo*-**8e** (74 mg, 0.14 mmol) and HgCl<sub>2</sub> (55 mg, 0.20 mmol) in dry acetone (20 mL), room temperature, 14 h. An excess of pyridine was added. Low-temperature (0 °C) flash chromatography over silica gel afforded (7*R*)-**9d** byproduct with 10% acetone in hexane mixture, followed by the orange product (-)-(*pS*)-**5** (50 mg, 0.098 mmol, 72% yield), which was eluted with a 40% acetone in hexane mixture. (-)-(*pS*)-**5**: [ $\alpha$ ]<sub>D</sub> (CH<sub>2</sub>Cl<sub>2</sub>, 298 K) -733° (*c* = 0.04 g/100 mL); CD (MeOH):  $\lambda$  247 (+6.6), 268 (-3.7), 326 (+8.8), 445 (-5.3) nm.

**(7S)-Tricarboxyl( $\eta^6$ -1-chloromercurio-7-methyl-N,N-dimethylbenzylamine)chromium(0) ((7R)-**9c**).** A solution of (7*S*)-( $\eta^6$ -7-methyl-N,N-dimethylbenzylamine)tricarboxylchromium<sup>46</sup> (800 mg, 2.80 mmol) and Hg(OAc)<sub>2</sub> (1.34 g, 4.20 mmol) in EtOH (25 mL) was stirred at reflux over 4 h under argon. The resulting solution was cooled to room temperature and filtered over Celite. Addition of a saturated solution of CaCl<sub>2</sub> in EtOH to the filtered solution afforded a yellow pale solid, which was filtered, washed with water, and dried over vacuum. Recrystallization with dry Et<sub>2</sub>O/hexane afforded the yellow complex (7*R*)-**9c** (820 mg, 1.58 mmol, 56% yield): [ $\alpha$ ]<sub>D</sub> (CH<sub>2</sub>Cl<sub>2</sub>, 298 K) -64.5° (*c* = 1.7 × 10<sup>-3</sup> M). Anal. Calcd for C<sub>13</sub>H<sub>14</sub>NO<sub>3</sub>ClCrHg: C, 29.94; H, 2.68; N, 2.68. Found: C, 29.84; H, 2.85; N, 2.62. The <sup>1</sup>H and <sup>13</sup>C NMR as well as IR spectroscopic data of this complex were identical with those measured for (7*S*)-**9c**.<sup>10</sup>

**Tetramethylammonium (SP-4-3)-Dichloro[2-(tricarboxyl( $\eta^6$ -phenyl- $\kappa$  C<sup>1</sup>)-chromium(0)}pyridine- $\kappa$ N]palladate(II) (**10b**).** A solution of **4** (50 mg, 0.058 mmol) with [Me<sub>4</sub>N]Cl (127 mg, 1.16 mmol) in dry acetone (10 mL) was stirred for 4 h at room temperature. The mixture was filtered over Celite and the solvent evaporated under vacuum. Recrystallization with CH<sub>2</sub>Cl<sub>2</sub>/hexane affords the product **10b** (25 mg, 0.046 mmol, 79% yield). **10b**: IR (CH<sub>2</sub>Cl<sub>2</sub>)  $\nu$ (CO) 1877, 1954 cm<sup>-1</sup>; <sup>1</sup>H NMR (C<sub>3</sub>D<sub>6</sub>O, 300 MHz)  $\delta$  9.60 (d, <sup>3</sup>*J* = 5.2 Hz, 1H, py), 8.00 (t, <sup>3</sup>*J* = 7.5 Hz, 1H, py), 7.78 (d, <sup>3</sup>*J* = 8.0 Hz, 1H, py), 7.34 (t, <sup>3</sup>*J* = 6.5 Hz, 1H, py), 6.44 (d, <sup>3</sup>*J* = 6.3 Hz, 1H, ArCr), 6.20 (d, <sup>3</sup>*J* = 6.5 Hz, 1H, ArCr), 5.56 (t, <sup>3</sup>*J* = 6.3 Hz, 1H, ArCr), 5.41 (t, <sup>3</sup>*J* = 6.3 Hz, 1H, ArCr), 3.47 (s, 12H, NMe<sub>4</sub>); <sup>13</sup>C{<sup>1</sup>H} NMR (C<sub>3</sub>D<sub>6</sub>O, 125 MHz)  $\delta$  235.7 (CO), 164.5, 151.8, 139.4,

123.7, 122.6, 119.2, 112.4, 100.0, 95.7, 92.2, 91.0, 56.0 (NMe<sub>4</sub>). Anal. Calcd for C<sub>18</sub>H<sub>20</sub>N<sub>2</sub>O<sub>3</sub>Cl<sub>2</sub>CrPd: C, 39.91; H, 3.72; N, 5.17. Found: C, 39.95; H, 3.65; N, 5.08.

**(SP-4-4)-[Bis(*N,N*-dimethylbenzylamine- $\kappa$ C,*N*)]palladium(II) (14a).** A solution of PdCl<sub>2</sub>(MeCN)<sub>2</sub> (110 mg, 0.42 mmol) in dry acetone (5 mL) was added dropwise to a mixture of **9a** (315 mg, 0.84 mmol) and [Me<sub>4</sub>N]Cl (466 mg, 4.25 mmol) in acetone (15 mL) at -20 °C. The resulting mixture was vigorously stirred and warmed to room temperature over 6 h. Then, the pink-brown mixture was filtered over Celite and the filtered solution was stripped of solvents. It is important to note that flash chromatography purification of the crude product was avoided, due to the sensitivity of **14a** to SiO<sub>2</sub>. Recrystallization from dry CH<sub>2</sub>Cl<sub>2</sub>/hexane afforded the yellow pale solid **14a** (95 mg, 0.25 mmol, 60% yield). Analytical data were in agreement with those reported in the literature.

**(SP-4-4)-[Bis(2-phenylpyridine- $\kappa$ C,*N*)]palladium(II) (14b).** The procedure for this reaction was similar to that described for **14a**. The conditions were slightly changed as follows: PdCl<sub>2</sub>(MeCN)<sub>2</sub> (133 mg, 0.51 mmol) in dry acetone (5 mL) was added dropwise to a mixture of **9d** (400 mg, 1.02 mmol) and [Me<sub>4</sub>N]Cl (1.12 g, 10.2 mmol) in acetone (20 mL) at -20 °C. The gray-white mixture was filtered over Celite to afford a yellow solution, which was stripped of solvent under reduced pressure. Recrystallization from dry CH<sub>2</sub>Cl<sub>2</sub>/hexane afforded **14b** (164 mg, 0.40 mmol, 80% yield). Flash chromatography purification was avoided for the same reasons mentioned previously for **14a**. All analytical data were in agreement with those reported for the same complex by von

Zelewsky and co-workers,<sup>40h</sup> except for the <sup>1</sup>H NMR spectrum in CDCl<sub>3</sub>, which we found was incompletely listed by the latter authors. Complex **14b**: <sup>1</sup>H NMR (CDCl<sub>3</sub>, 300 MHz)  $\delta$  8.63 (d, <sup>3</sup>J = 5.0 Hz, 2H, py), 8.08 (d, <sup>3</sup>J = 7.4 Hz, 2H, Ph), 7.88 (d, <sup>3</sup>J = 7.7 Hz, 2H, py), 7.83 (t, <sup>3</sup>J = 7.6 Hz, 2H, py), 7.64 (d, <sup>3</sup>J = 7.5 Hz, 2H, Ph), 7.29 (m, 4H), 7.16 (t, <sup>3</sup>J = 7.4 Hz, 2H, Ph).

**Acknowledgment.** We thank the Centre National de la Recherche Scientifique (J.-P.D., M.P., A.d.C., N.K.-G.), the Swiss National Science Foundation (L.V., J.L.), the Sandoz Family Foundation (J.L.), and the Coordenação de Aperfeiçoamento de Pessoal de Nível Superior (A.B.) for financial support. We also gratefully acknowledge the expertise provided by Prof. Howard Flack and Dr. Gerald Bernardinelli, from the University of Geneva, in helping us analyzing some of our chiral structures.

**Supporting Information Available:** Complete listings of pertinent X-ray diffraction analysis acquisition and refinement data and of interatomic distances and angles for complexes **8a–e** mentioned in this article and for complexes (p*S*)-**5** and (p*R*)-**5** (both dichloromethane and acetone solvates); these data are also available as CIF files. This material is available free of charge via the Internet at <http://pubs.acs.org>.

OM030433L

(46) Maisse, A.; Djukic, J. P.; Pfeffer, M. *J. Organomet. Chem.* **1998**, 567, 65.