

Oxodienyl/Alkyne Coupling Reactions in Half-Open Ruthenocenes(II) and Related Species of Ru(IV)

M. Esther Sánchez-Castro, Armando Ramirez-Monroy, and
M. Angeles Paz-Sandoval*

Departamento de Química, Centro de Investigación y de Estudios Avanzados del IPN,
Apartado Postal 14-740, México 07000, D.F., México, and Av. IPN # 2508,
San Pedro Zacatenco, México 07360, D.F., México

Received January 10, 2005

A successful synthesis of Cp*Ru(η^5 -CH₂CHCHCHO) (**1**) was obtained by chromatography on neutral deactivated alumina of Cp*Ru(1-4- η -CH₂CHCHCHOSiMe₃)Cl (**2**). The disproportionation reaction of **2** affords compounds **1** and Cp*Ru(1-3- η -endo-syn-CH₂CHCHCHO)-Cl₂ (**3**). Reaction of compound **1** with diphenylacetylene affords compounds Cp*Ru[1-5- η -syn-CH(Ph)C(Ph)CHCHCH(CHO)] (**6**), Cp*Ru[1,4,5- η -C(Ph)C(Ph)CH₂CHCH₂]CO (**7**), Cp*Ru(1-3- η -CH₂CHCHCHO)(η^2 -PhC≡CPh) (**8**), and compounds with cyclic structures, such as Cp*Ru[1,6,7,10,11- η -CH(CH)₄CCHC(Ph)CH(CH)₂C(O)CH(C₆H₄)CH(Ph)] (**9**) and Cp*Ru[3,4,5- η -C(Ph)C(Ph)CHCHCHC(O)](η^2 -PhCH=CHPh) (**10**). Reaction of compound **3** with diphenylacetylene shows the syn-aldehyde derivative **6**, as well as the corresponding kinetic isomer **11**, in which the terminal aldehyde group is in anti-position. Treatment of [Cp*RuCl₂]₂ with CH₂CHCHCHOSiMe₃ affords compound Cp*Ru[1-3- η -endo-syn-(Me)CHCHCH(OEt)]Cl₂ (**5**). The Ru(IV) complex **5** reacts with diphenylacetylene to give the cyclic 1,2-diphenyl-3-methylcyclopentadienyl complex Cp*Ru[η^5 -C(Ph)C(Ph)C(Me)CHCH] (**12**). The investigation of the reactivity of the 2,4-dimethyl-oxopentadienyl of Cp*Ru[η^5 -CH₂C(Me)CHC(Me)O] (**4**) with excess of diphenylacetylene or dimethyl acetylenedicarboxylate showed the oxopentadienyl/alkyne coupling products Cp*Ru[1-5- η -syn-CH(Ph)C(Ph)CHC(Me)CH(COMe)] (**13**) and Cp*Ru[1-5- η -syn-CH(COOMe)C(COOMe)CHC(Me)CH(COMe)] (**16**), along with small amounts of Cp*Ru[1-5- η -syn-CH(Ph)C(Ph)CHC{CH₂C(Ph)CH(Ph)}CH(COMe)] (**14**) and Cp*Ru[1-5- η -syn-CH(COOMe)C(COOMe)CHC{CH₂C(COOMe)CH(COOMe)}CH(COMe)] (**17**), which are products of a second coupling reaction through the activation of one of the C–H bonds of the 2-methyl substituent. Crystallographic studies are reported for compounds **6**, **9**, **13**, **14**, and **17**. Cp*Ru[1-5- η -CH₂C(Me)CHC{CH₂C(Me)₂CH₂C(O)}CH] (**18**) was also studied in solid state and in solution.

Introduction

There is widespread interest in organoruthenium reactions with alkynes,¹ especially terminal and internal alkynes, which involve hydrogen, alkyl, aryl, or alkoxy-carbonyl substituents, because such systems could induce insertion reactions in a variety of chloro- or hydrido-ruthenium(II)^{2–10} and -(IV)⁴ complexes. Con-

venient precursors of substituted cyclopentadienones from reactions of compounds with labile coordinated ligands [CpRu(CO)(MeCN)₂] [Cp' = Cp, Cp*] with various alkynes¹¹ and a variety of examples of the ruthenium-alkyne chemistry have been reported. Some of the latter include (a) the addition of phenyl and diphenylacetylene to the cationic complex [CpRu{(k¹-P)(4-5- η)-PPh₂CH₂CH₂CH=CH₂}(MeCN)]PF₆, which affords η^4 -butadiene compounds [CpRu{(k¹-P)(4-7- η)-PPh₂CH₂CH₂CH=CHCR¹=CHR²}]PF₆,¹² (b) the cross-addition of acetylenes to the coordinated olefin in the chelate neutral ruthenium complex Ru(1-5,9-10- η -C₅-Me₄CH₂OCH₂CH=CH₂)(CO)Cl, which gives the corresponding cationic diene chelates,¹³ (c) a number of specific reactions related to the bis-insertion process of

* To whom correspondence should be addressed. E-mail: mpaz@cinvestav.mx.

(1) Davies, S. G.; McNally, J. P.; Smallridge, A. J. *Adv. Organomet. Chem.* **1990**, *30*, 1.

(2) Masuda, K.; Ohkita, H.; Kurumatani, S.; Itoh, K. *Organometallics* **1993**, *12*, 2221, and references therein.

(3) Werner, H.; Esteruelas, M. A.; Otto, H. *Organometallics* **1986**, *5*, 2295.

(4) Older, C. M.; Stryker, J. M. *Organometallics* **2000**, *19*, 2661, and references therein.

(5) (a) Lutsenko, Z. L.; Aleksandrov, G. G.; Petrovskii, P. V.; Shubina, E. S.; Andrianov, V. G.; Struchkov, Y. T.; Rubezhov, A. Z. *J. Organomet. Chem.* **1985**, *281*, 349. (b) Lutsenko, Z. L.; Petrovskii, P. V.; Bezrukova, A. A.; Rubezhov, A. Z. *Bull. Acad. Sci. USSR Chem. Sci.* **1988**, *4*, 855.

(6) Crocker, M.; Dunne, B. J.; Green, M.; Orpen, A. G. *J. Chem. Soc. Dalton* **1991**, 1589.

(7) Older, C. M.; Stryker, J. M. *J. Am. Chem. Soc.* **2000**, *122*, 2784.

(8) Older, C. M.; Stryker, J. M. *Organometallics* **1998**, *17*, 5596, and references therein.

(9) (a) Torres, M. R.; Vegas, A.; Santos, A. *J. Organomet. Chem.* **1987**, *326*, 413. (b) Torres, M. R.; Vegas, A.; Santos, J.; Ros, A. *J. Organomet. Chem.* **1986**, *309*, 169.

(10) Campion, B. K.; Heyn, R. H.; Tilley, T. D. *Organometallics* **1990**, *9*, 1106.

(11) Růba, E.; Mereiter, K.; Soldouzi, K.; Gemel, C.; Schmid, R.; Kirchner, K.; Bustelo, E.; Puerta, M. C.; Valerga, P. *Organometallics* **2000**, *19*, 5384.

(12) Slugovc, C.; Mereiter, K.; Schmid, R.; Kirchner, K. *Organometallics* **1999**, *18*, 1011.

dimethyl acetylenedicarboxylate with an alkenylruthenium complex;^{9a} and (d) the transformation of Ru(IV) allyl complexes to their corresponding Ru(II) butadiene when the CpRu(η^3 -crotyl)Cl₂ is eluted in a silica gel column and a methyl C–H bond is activated to give CpRu(η^4 -butadiene)Cl. This conversion depends on the retention time on a silica gel column and on the character of the supports used.¹⁴ In the field of mechanistic studies, the cotrimerization between a coordinated diene and two acetylene molecules, by means of the Cp^{*}Ru⁺ fragment and [4+2] cyclodimerization, has been published.² Current extensive studies on the properties and reactivity of several metal-mediated allyl/alkyne cycloaddition reactions using cationic late transition metal complexes of the form [(C_nR_n)M(η^3 -allyl)(η^2 -alkyne)]⁺ [Co, Rh, Ir, *n* = 5; Ru, Os, *n* = 6] have allowed the preparation of substituted η^5 -cyclopentadienyl^{4,5a,8,15} and η^5 -cycloheptadienyl complexes.^{4,16} However, in the case of the coordinated hexamethylbenzene complex (η^6 -hexamethylbenzene)Ru(allyl)(OTf) a demethylation of the aromatic ring has also been observed. In particular, coupling reactions with neutral ruthenium(II) showed that stable intermediates, such as Cp^{*}Ru(η^3 -allyl)(η^2 -alkyne) [alkyne = diphenylacetylene, 2-butyne, 1-(trimethylsilyl)propyne, and bis(trimethylsilyl)acetylene (BTMSA)], have been isolated.⁴ These intermediates (with the exception of BTMSA) suffer an allyl/alkyne coupling produced by heating, which results in the formation of the acyclic 1,2-disubstituted η^5 -pentadienyl complexes for alkyl- and aryl-substituted alkynes rather than cycloadducts, via an unsaturated σ,π -vinyl-olefin complex. This was demonstrated when the Cp^{*}Ru(η^3 -*exo*-allyl)(η^2 -alkyne) (alkyne = diphenylacetylene or 2-butyne) under carbon monoxide suppressed the formation of the corresponding η^5 -pentadienyl complex and Cp^{*}Ru[1,4,5- η -C(R)C(R)CH₂CHCH₂](CO) (R = Me, Ph)¹⁷ were isolated. These studies establish that the coupling of some mixed alkynes is particularly facile and that the presence of alkyl substituents on the η^3 -allyl ligand complicates the allyl/alkyne reactivity manifold.⁴

The oxodienyl compound Cp^{*}Ru(1-3- η -*exo*-*syn*-CH₂-CHCHCHO)(η^2 -PhC≡CPh) (**8-*exo***)¹⁸ analogue to Cp^{*}Ru(η^3 -*exo*-allyl)(η^2 -PhC≡CPh) was obtained from the reaction of diphenylacetylene with the butenyloxy dimer [Cp^{*}Ru- μ -1,2,5- η -CH₂CH(CH₂)₂O)]₂, and it will be compared to Cp^{*}Ru(1-3- η -*endo*-*anti*-CH₂CHCHCHO)(η^2 -PhC≡CPh) (**8-*endo***), which was isolated in this work.

We describe herein a comparative study of the reactivity of the different oxidation states of Cp^{*}Ru(II) or -(IV) complexes, as well as the influence on the allyl and oxodienyl ligands coordinated to the Cp^{*}Ru complexes toward diphenylacetylene and dimethyl acetylenedicarboxylate. The influence of the methyl substituents on

Scheme 1

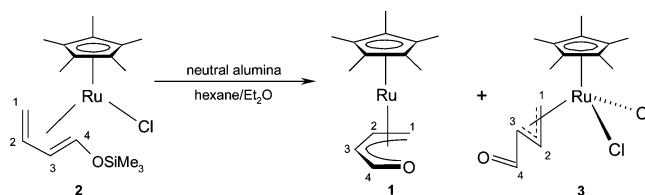

the oxopentadienyl ligands is established in the reaction of diphenylacetylene with Ru(II) compounds Cp^{*}Ru(η^5 -CH₂CHCHCHO) (**1**) and Cp^{*}Ru[η^5 -CH₂C(Me)CHC(Me)O] (**4**). The molecular structures of the resulting highly functionalized η^5 -pentadienyl complexes are reported. The Ru(IV) oxodienyl complexes Cp^{*}Ru(1-3- η -*endo*-*syn*-CH₂CHCHCHO)Cl₂ (**3**) and Cp^{*}Ru[1-3- η -*endo*-*syn*-(Me)CHCHCH(OEt)]Cl₂ (**5**) react with diphenylacetylene to afford acyclic and cyclic ruthenocene complexes, respectively. The reaction of compound **4** with diphenylacetylene and dimethyl acetylenedicarboxylate gives evidence of one and two coupling reactions in each case. The unexpected compound Cp^{*}Ru[1-5- η -CH₂C(Me)CHC{CH₂C(Me)₂CH₂C(O)}CH] (**18**) is described and related to the half-open metallocenes which bear the functional group Cp^{*}Ru(R-6-oxa-1-5- η -heptadienyl) (R = 2-Me, 2,3-C₆H₁₂) and the optically active pentadienyl compound Cp^{*}Ru[2-methyl-4,5-(dimethyl-bicyclo[3.1.1]heptane)1-5- η -pentadienyl].¹⁹ The crystal structures of representative compounds are presented.

Results and Discussion

The oxopentadienyl compound Cp^{*}Ru(η^5 -CH₂CHCHCHO) (**1**) was prepared in 67% yield by chromatography on neutral deactivated alumina²⁰ of Cp^{*}Ru(1-4- η -CH₂-CHCHCHOSiMe₃)Cl (**2**), which was obtained from the reaction of (Cp^{*}RuCl₂)₂ or (Cp^{*}RuCl)₄ and trimethylsilyloxybutadiene in THF. The disproportionation reaction of **2** affords compounds **1** and Cp^{*}Ru(1-3- η -*endo*-*syn*-CH₂CHCHCHO)Cl₂ (**3**) (Scheme 1), along with the spectroscopic evidence of Me₃SiCl and their corresponding products, Me₃SiOH and Me₃SiOSiMe₃, from the hydrolysis and condensation reactions. All these species were carefully studied by ¹H, ¹³C, and ²⁹Si NMR.²¹

Complete characterization was carried out for compounds **1**, **2**, and **3** (Tables 1 and 3).

The isolation of compound **1** is particularly interesting because it has been reported that the preparation of methyl-substituted oxopentadienyl compounds such as Cp^{*}Ru(η^5 -oxopentadienyl) [oxopentadienyl = 2,4-Me₂- η^5 -C₄H₃O (**4**), 3,5-Me₂- η^5 -C₄H₃O] has been obtained from (Cp^{*}RuCl)₄ and the appropriate enone or enal,²² whereas Cp^{*}Ru(3-Me- η^5 -C₄H₄O) has also been isolated, but in this case, along with the 2-methylallyl complex [Cp^{*}Ru(η^3 -CH₂C(Me)CH₂)CO]. Similar reactions designed to prepare analogous species with fewer methyl groups

(13) Gusev, O. V.; Kal'sin, A. M.; Morozova, L. N.; Petrovskii, P. V.; Lyssenko, K. A.; Tok, O. L.; Noels, A. F.; O'Leary, S. R.; Maitlis, P. M. *Organometallics* **1999**, *18*, 5276.

(14) Masuda, K.; Saitoh, M.; Aoki, K.; Itoh, K. *J. Organomet. Chem.* **1994**, *473*, 285.

(15) (a) Schwiebert, K. E.; Stryker, J. M. *Organometallics* **1993**, *12*, 600. (b) Nehl, H. *Chem. Ber.* **1993**, *126*, 1519.

(16) (a) Dzwiniel, T. L.; Etkin, N.; Stryker, J. M. *J. Am. Chem. Soc.* **1999**, *121*, 10640. (b) Etkin, N.; Dzwiniel, T. L.; Schwiebert, E.; Stryker, J. M. *J. Am. Chem. Soc.* **1998**, *120*, 9702. (c) Schwiebert, K. E.; Stryker, J. M. *J. Am. Chem. Soc.* **1995**, *117*, 8275.

(17) Older, C. M.; Stryker, J. M. *Organometallics* **2000**, *19*, 3266, and references therein.

(18) Koelle, U.; Kang, B. S.; Thewalt, U. *Organometallics* **1992**, *11*, 2893.

(19) Bosch, H. W.; Hund, H.-U.; Nietlispach, D.; Salzer, A. *Organometallics* **1992**, *11*, 2087.

(20) Chen, J.; Daniels, L. M.; Angelici, R. J. *J. Am. Chem. Soc.* **1990**, *112*, 199.

(21) Sánchez-Castro M. E.; Paz-Sandoval, M. A. Unpublished results.

(22) Trakarnpruk, W.; Arif, A. M.; Ernst, R. D. *Organometallics* **1992**, *11*, 1686.

Table 1. ^1H NMR Data^a for Compounds 1–5

compound	H1a	H1s	H2 or Me2	H3	H4 or Me4	Cp*
1	2.30 (d) ^b $J_{\text{H1a,H2}} = 10.2$	3.37 (d) $J_{\text{H1s,H2}} = 8.5$	4.28 (m)	4.61 (d) $J_{\text{H2,H3}} = 6.6$	6.90 (s,br)	1.62 (s)
	1.72 (d) ^c $J_{\text{H1a,H2}} = 10.9$	3.37 (d) $J_{\text{H1s,H2}} = 8.3$	4.46 (m)	4.88 (d) $J_{\text{H2,H3}} = 5.8$	6.88 (s,br)	1.84 (s)
2^d	1.75 (dd) ^b $J_{\text{H1a,H1s}} = 1.8$ $J_{\text{H1a,H2}} = 10.5$	2.85 (dd) $J_{\text{H1a,H1s}} = 1.8$ $J_{\text{H1s,H2}} = 7.7$	3.75 (ddd) $J_{\text{H2,H3}} = 5.8$ $J_{\text{H2,H1s}} = 7.7$ $J_{\text{H1a,H2}} = 10.5$	4.50 (dd) $J_{\text{H2,H3}} = 5.7$ $J_{\text{H3,H4}} = 7.5$	4.98 (d) $J_{\text{H3,H4}} = 7.5$	1.38 (s)
	1.35 (dd) ^c $J_{\text{H1a,H1s}} = 1.7$ $J_{\text{H1a,H2}} = 10.6$	2.96 (dd) $J_{\text{H1a,H1s}} = 1.7$ $J_{\text{H1s,H2}} = 7.7$	4.17 (m)	4.60 (m) ^e	4.61 ^e	1.61 (s)
3	1.58 (d) ^b $J_{\text{H1a,H2}} = 9.7$	4.08 (d) $J_{\text{H1s,H2}} = 6.2$	5.83 (m)	1.99 (dd) $J_{\text{H2,H3}} = 9.5$ $J_{\text{H3,H4}} = 7.1$	10.28 (d) $J_{\text{H3,H4}} = 7.3$	1.00 (s)
	2.40 (d) ^c $J_{\text{H1a,H2}} = 9.7$	4.36 (d) $J_{\text{H1s,H2}} = 6.4$	6.15 (ddd) $J_{\text{H1s,H2}} = 6.2$ $J_{\text{H2,H3}} = 9.7$ $J_{\text{H1a,H2}} = 9.7$	2.55 (dd) $J_{\text{H2,H3}} = 9.5$ $J_{\text{H3,H4}} = 7.1$	10.14 (d) $J_{\text{H3,H4}} = 7.1$	1.64 (s)
4^f	2.28 (s) ^b	3.25 (s)	1.96 (s)	4.68 (s)	1.48 (s)	1.59 (s)
5^g	1.58 (s) ^c	3.10 (s)	1.99 (s)	4.80 (s)	1.54 (s)	1.68 (s)
	1.92 (m) ^b	1.64 (d) $J_{\text{H1a,Me1s}} = 6.2$	5.03 (t) $J_{\text{H1a,H2}} = 9.1$ $J_{\text{H2,H3}} = 9.1$	4.90 (d) $J_{\text{H2,H3}} = 8.8$	H4', H4'' 4.08 (m) 3.52 (m)	1.11(s)
	2.56 (dq) ^c $J_{\text{H1a,Me1s}} = 6.2$ $J_{\text{H1a,H2}} = 9.6$	1.62 (d) $J_{\text{H1a, Me1s}} = 6.2$	5.00 (t) $J_{\text{H1a,H2}} = 9.3$ $J_{\text{H2,H3}} = 9.3$	5.37 (d) $J_{\text{H2,H3}} = 8.8$	H4', H4'' 4.05 (m) 3.91 (m)	1.58 (s)

^a For numbering see corresponding schemes. δ (ppm); H1a = hydrogen 1-*anti*; H1s = hydrogen 1-*syn*; J = coupling constant in Hz, (d) doublet; (s) singlet; (q) quartet; (m) multiplet; (br) broad. ^b C₆D₆. ^c CDCl₃. ^d SiMe₃: 0.31 (s)^b and 0.21 (s)^c; ²⁹Si NMR data for this compound: 22.9^b and 23.3^c ppm. ^e Overlapped signals; ^f Reference 28; ^g Me5: 1.12^b (overlapped with Cp*signal); 1.33^c (t) $J_{\text{H4,H5}} = 7.0$.

have led to only CO extrusion and coordination, as observed for the 2-methylallyl derivative.²³ Actually, the reaction between [Cp*RuCl]₄ with crotonaldehyde, in the presence of potassium carbonate, led to the exclusive isolation of (Cp*Ru)₂(μ_2 -HC₂Me)(μ_2 -CO), instead of the expected Cp*Ru(η^5 -CH₂CHCHCHO) (**1**).²²

An equilibrium between the oxodienyl complex with a coordinated η^2 -crotonaldehyde Cp*Ru(1-3- η -CH₂-CHCHCHO)(1-2- η -(Me)CHCHCHO) and the oxopentadienyl complex Cp*Ru(η^5 -CH₂CHCHCHO) (**1**) has been observed manifested by ^1H NMR from the reaction of [Cp*Ru(OMe)]₂ with crotonaldehyde, but the η^5 -complex has not been isolated. Koelle et al. mentioned that such ruthenium oxopentadienyl complexes had been isolated only with stabilizing methyl groups.²⁴

We have found that once compound **1** has been isolated, it is reasonably stable, and in fact the first discussion of its chemistry is presented in this paper.

(a) Reactions of Cp*Ru(η^5 -CH₂CHCHCHO) (1**) with Diphenylacetylene.** Treatment of **1** with an excess of PhC≡CPh (1:2) under reflux of THF for 24 h afforded, according to the ^1H NMR of the crude of reaction, compound **1** (small amount), Cp*Ru[1-5- η -syn-CH(Ph)C(Ph)CHCH(CHO)] (**6**) as a major product, and PhC≡CPh, Scheme 2.

After evaporation of the solvent and purification by chromatography over neutral alumina, there were three different fractions that were eluted with hexane, hexane/diethyl ether, and diethyl ether, respectively. The ^1H NMR showed that, from the first fraction, excess PhC≡CPh along with the compound Cp*Ru[1,4,5- η -C(Ph)C(Ph)CH₂CHCH₂]CO (**7**)¹⁷ were obtained and separated by a second chromatography. The second fraction showed the exclusive separation of compound

6 in 35% yield, and the third fraction showed the formation of [Cp*Ru(1-3- η -endo-*anti*-CH₂CHCHCHO)-(η^2 -PhC≡CPh)] (**8-endo**), Scheme 3.

Compounds **7** and **8-endo** were formed during the chromatographic procedure and, interestingly, the σ,π -vinyl-olefin complex **7** was formed by the extrusion and coordination of the CO of compound **1**, as described in Scheme 4.

Compound **7** is remarkably stable, and it had already been isolated by Stryker et al. from the reaction of [Cp*Ru(η^3 -*exo*-CH₂CHCH₂)(η^2 -PhC≡CPh)] under carbon monoxide atmosphere (60 psig), which gave indirect evidence of the intermediate species proposed in the formation of the pentadienyl complexes Cp*Ru[η^5 -C(Ph)C(Ph)CHCHCH₂].¹⁷

According to spectroscopic NMR data (Tables 2 and 4), the yellow complex **8-endo** has the oxodienyl ligand in η^3 -*endo-anti* conformation and coordinated η^2 -diphenylacetylene. Compound **8-endo** is an analogue to the allyl complex [Cp*Ru(η^3 -*exo*-CH₂CHCH₂)(η^2 -PhC≡CPh)],^{4,17} but contrastingly, it does not undergo oxodienyl/alkyne coupling upon warming at 60 °C in C₆D₆ (12 h) or 50 °C in CDCl₃ (24 h) to form the corresponding open-chain η^5 -pentadienyl complex **6**. After monitoring the reaction of **8-endo** in C₆D₆, there was evidence of only free diphenylacetylene along with a singlet at 1.30 ppm for the Cp* ligand, whereas **8-endo** in CDCl₃ showed the formation of compound **3** and free diphenylacetylene. According to these results, compound **8-endo** is not a precursor of **6** in the reaction of **1** with diphenylacetylene. However, heating [Cp*Ru(1-3- η -*exo-syn*-CH₂CHCHCHO)(η^2 -PhC≡CPh)] (**8-exo**)¹⁸ with the oxodienyl ligand in an η^3 -*exo-syn* conformation and coordinated η^2 -diphenylacetylene shows that it is indeed an intermediate, evidencing the influence of the conformation of the η^3 -oxodienyl ligand in these coupling reactions.²⁵

(23) Trakarnpruk, W., Arif, A. M.; Ernst, R. D. *Organometallics* **1994**, *13*, 2423.

(24) Koelle, U. *Chem. Rev.* **1998**, *98*, 1313, and references therein.

Table 2. ¹H NMR Data^a for Compounds 6–8 and 10–18

compound	H1	R3	R4	H5	R6	Cp*	Ph or OMe
6	1.78 (s) ^b	5.18 (d) $J_{H3,H4} = 6.1$	4.61 (dd) $J_{H4,H5} = 8.0$ $J_{H3,H4} = 6.2$	2.23 (t) $J_{H4,H5} = 7.5$ $J_{H5,H6} = 7.5$	9.23 (d) $J_{H5,H6} = 6.2$	1.31 (s)	6.64 (d), 6.89 (dd), 7.12 (m), 7.34 (dd)
	1.89 (s) ^c	5.46 $J_{H3,H4} = 6.0$	4.93 (dd) $J_{H4,H5} = 7.8$ $J_{H3,H4} = 6.1$	2.01 (t) $J_{H4,H5} = 7.5$ $J_{H5,H6} = 7.5$	8.97 (d) $J_{H5,H6} = 7.0$	1.47 (s)	6.57 (d), 6.88 (m), 7.26 (m)
7		3.89 (dd) ^b $J_{H4,H3} = 6.6$ $J_{H3,H3'} = 16.5$; 2.62 (dd)	3.63 (ddd) $J_{H5a,H4} = 11.7$ $J_{H5b,H4} = 8.0$ $J_{H4,H3} = 6.5$	3.05 (d) ^c $J_{H5a,H4} = 11.7$ 2.15 (d) ^c $J_{H5b,H4} = 8.0$		1.24 (s)	6.92–7.52 (m)
		3.73 (dd) ^c $J_{H4,H3} = 6.2$	$J_{H4,H3'} = 7.3$ $J_{H3,H3'} = 16.5$ $J_{H3,H3'} = 16.0$; 2.38 (dd)	2.97 (d) ^c $J_{H5a,H4} = 11.1$ 2.24 (d) ^c $J_{H5b,H4} = 8.2$		1.46 (s)	6.82–7.34 (m)
		3.86 (d) ^b $J_{H3,H4} = 6.6$	$J_{H4,H3} = 6.2$ $J_{H3,H4} = 6.6$	4.11 (d) $J_{H4,H5} = 4.6$		1.24 (s)	6.56 (d), 6.78 (d), 6.80 (t), 7.01 (m), 7.20 (m), 7.43 (t), 8.04 (d), 8.31 (d)
10^e			3.74 (dd) $J_{H4,H5} = 4.9$ $J_{H3,H4} = 6.3$			1.77 (s)	7.03 (t), 7.05 (d), 7.08–7.15 (m), 7.24–7.26 (m)
11	2.49 (s) ^c	5.53 (d) $J_{H3,H4} = 6.0$	5.05 (t) $J_{H3,H4} = 6.4$ $J_{H4,H5} = 7.2$	2.16 (t) $J_{H4,H5} = 7.8$ $J_{H5,H6} = 7.8$	8.67 (d) $J_{H5,H6} = 7.9$	1.48 (s)	6.72 (d), 7.00 (m), 7.51 (m)
12		1.87 (s) ^c	4.23 (d) $J_{H3,H4} = 2.3$	4.47 (d) $J_{H3,H4} = 2.3$		1.36 (s)	7.03 (t), 7.05 (d), 7.08–7.15 (m), 7.24–7.26 (m)
13	2.49 (s) ^b	5.06 (s)	2.43 (s)	1.03 (s)	1.99 (s)	1.38 (s)	6.73 (d), 6.90 (m), 7.42 (dd)
14	2.58 (s) ^b	5.38 (s)	3.02 (dd) $J_{H4,H4'} = 15.3$ $J_{H4,H4''} = 1.4$	1.07 (s)	1.87 (s)	1.56 (s)	6.71 (d), 6.91 (m), 7.06 (m), 7.44 (dd), 7.50 (d)
15	3.73 (s) ^b	5.29 (s)	5.21 (dd) $J_{H4,H4'} = 15.3$ $J_{H4',H4''} = 1.4$ 6.85 ^f	1.91 (s)	2.09 (s)	1.26 (s)	6.92 (m), 7.13 (t), 7.36 (dd)
16	1.62 (s) ^b	5.24 (s)	2.29 (s)	0.79 (s)	1.78 (s)	1.62 (s)	3.50 (s), 3.62 (s)
17	1.67 (s) ^b	5.43 (s)	2.84 (dd) $J_{H4,H4'} = 14.7$ $J_{H4,H4''} = 1.4$	0.81 (s)	1.70 (s)	1.56 (s)	3.29 (s), 3.46 (s) 3.55 (s), 3.56 (s)
18	0.72 (d) ^b $J_{H1a,H1s} = 3.1$	2.34 (d) $J_{H1a,H1s} = 3.2$	4.90 (dd) $J_{H4,H4'} = 14.7$ $J_{H4',H4''} = 1.4$ 6.12 (t) $J_{H4',H4} = 1.4$ $J_{H4'',H4'} = 1.4$	4.77 (s)	2.10 (m)	1.46 (s)	1.74 (s,br) (H5) 2.10 (d) (H6) ^g $J_{H6,H6'} = 16.1$ 2.34 (dd) (H6') ^g $J_{H6,H5} = 2.2$, $J_{H6,H6'} = 16.1$ 0.87 (s) (Me7) ^g 1.07 (s) (Me8) ^g
	0.68 (d) ^c $J_{H1a,H1s} = 3.2$	2.40 (d) $J_{H1a,H1s} = 3.2$	2.95 (ddd) $J_{H1s,H2} = 7.0$ $J_{H2,H3} = 7.5$ $J_{H1a,H2} = 11.0$	5.05 (s)	2.08 (d) $J_{H4,H4'} = 15.1$ 1.88 (d) $J_{H4,H4'} = 15.3$	1.64 (s)	1.34 (s, br) (H5) 2.28 (d) (H6) ^g $J_{H6,H6'} = 16.1$ 2.58 (dd) (H6') ^g , $J_{H6,H5} = 2.8$, $J_{H6,H6'} = 16.2$ 1.01 (s) (Me7) ^g 1.03 (s) (Me8) ^g

^a δ (ppm); H1a = hydrogen 1-anti; H1s = hydrogen 1-syn; J = coupling constant in Hz. (d) doublet; (s) singlet; (q) quartet; (m) multiplet. ^b C₆D₆. ^c CDCl₃. ^d Vinylic hydrogens, H5a, H5s. ^e *cis*-Stilbene hydrogens: 2.56 (d), $J_{H6,H7} = 9.5$ Hz, 2.76 (d), $J_{H6,H7} = 9.5$ Hz. ^f Overlap with Ar–H. ^g Assignment could be reversed.

Table 3. ^{13}C NMR Data^a of Compounds 1–5

compound	C1	C2	C3	C4	C(Cp*)	C(Me,Cp*)
1	55.5 ^c	90.8	88.0	123.0	89.4	11.1
2 ^d	50.8 ^b	83.7	84.4	108.6	94.0	9.5
	50.9 ^c	84.2	84.2	107.9	93.7	9.3
3	66.3 ^b	98.6	68.2	201.0	106.4	9.2
	66.8 ^c	99.1	68.2	201.6	107.5	9.8
4 ^e	54.8 ^b	101.2	84.0	135.0	87.1	10.6
5 ^f	16.5	68.2	84.2	127.0	100.2	9.6

^a δ (ppm). ^b C_6D_6 . ^c CDCl_3 . ^d SiMe_3 : 0.52^b; 0.08^c. ^e 23.2 (C5), 25.1 (C6); ref 28. ^f 69.2 (C5), 14.5 (C6).

Scheme 2

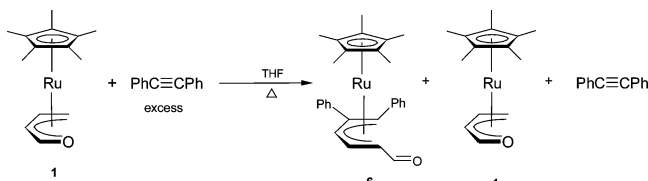

Scheme 3

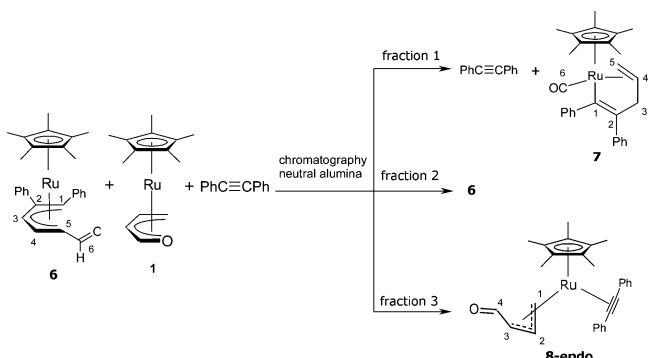

Scheme 4

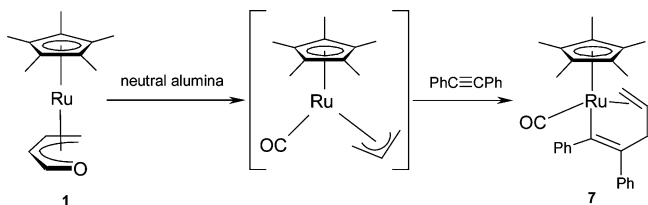

Scheme 5

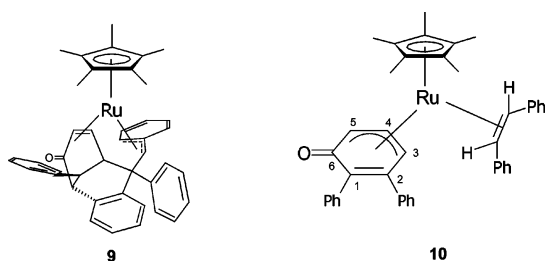

The amount of diphenylacetylene is crucial in the species formed, as it was demonstrated that when under identical experimental conditions but with a different stoichiometry, a 1:3.5 ratio of **1** and diphenylacetylene instead of 1:2, compounds **6**, **7**, **8-exo**, **8-endo**, $\text{Cp}^*\text{Ru}[1,6,7,10,11-\eta\text{-CH}(\text{CH})_4\text{CCHC}(\text{Ph})\text{CH}(\text{CH})_2\text{C}(\text{O})\text{CH}(\text{C}_6\text{H}_4)\text{CH}(\text{Ph})]$ (**9**), and $\text{Cp}^*\text{Ru}[3,4,5-\eta\text{-C}(\text{Ph})\text{C}(\text{Ph})\text{CHCHCH}(\text{O})](\eta^2\text{-PhCH}=\text{CHPh})$ (**10**) were obtained (in small amounts, except compound **6**) after chromatographic separation as described in the Experimental Section. A mixture of diphenylacetylene and compounds

6 and **8-exo** after recrystallization, with diethyl ether at room temperature, showed the transformation of **8-exo** into compound **6** as yellow crystals, which precipitated along with red-orange needles of compound **9**, and these were selected manually. The corresponding crystal structure (vide infra) shows that compound **9** is formed by the cyclization of the pentadienyl ligand in **6**, which gives an η^2 -coordination, and a second coupling of diphenylacetylene to the central carbon atom of the pentadienyl. This second molecule of alkyne is also coordinated to the metal through two carbon atoms from one of the phenyl rings and the next carbon atom out of the ring, which affords an η^3 -benzyl bond, Scheme 5. The structural view, as well as selected bond distances and angles, will be discussed below. Attempts to reproduce the formation of compound **9** were unsuccessful. Compound **8-endo**, isolated from a more polar fraction than **8-exo**, was recrystallized in diethyl ether at -5°C , giving yellow needles in very low yield (2%).

Recrystallization of compound **10** with pentane at -78°C , after a second chromatography on neutral alumina with diethyl ether as eluent, gave a brown-red solid, which, according to one- and two-dimensional NMR experiments, corresponds to the six-membered ring molecule **10**, in which a *cis*-stilbene is coordinated to ruthenium, Scheme 5. The ^1H NMR spectrum (Table 2, footnote e) of **10** shows a singlet for the Cp^* (1.24 ppm) and doublets centered at 2.76 and 2.56 with a common coupling constant of 9.5 Hz, consistent with *cis*-hydrogens in the stilbene molecule.²⁶ The COSY experiment shows the corresponding correlation of the three allylic hydrogens [$\delta = 4.11$ (d), $J_{4,5} = 4.6$ Hz, H5; $\delta = 3.74$ (dd), $J_{4,5} = 4.9$, $J_{3,4} = 6.3$ Hz, H4; $\delta = 3.86$ (d), $J_{3,4} = 6.6$ Hz, H3]. ^{13}C NMR (Table 4) shows that the olefinic carbon atoms in the coordinated stilbene are at 61.1 and 51.1 ppm, whereas the noncoordinated double bond of the “cyclohexa- η^3 -dienylone” is at 148.5 and 140.0 ppm and the carbonyl is at 205.3 ppm.

(b) **Reaction of $\text{Cp}^*\text{Ru}(1-3-\eta\text{-endo-syn-CH}_2\text{-CHCHCHO})\text{Cl}_2$ (**3**) with Diphenylacetylene.** Compound **3** treated with excess diphenylacetylene (1:5), under reflux of THF for 5 h, and in the presence of zinc as a reducing reagent, gave compound **11**, which is an isomer of compound **6**. These isomers differ in the chemical shifts of the terminal *anti* hydrogens (H1 and H4) of the pentadienyl ligand, Table 2 and Scheme 6. Compound **11** could be partially precipitated from diethyl ether at -5°C as orange needles, and after 2 h in solution of CDCl_3 it is transformed into compound **6**; the remaining compound **11** in the presence of diphenylacetylene was treated with neutral alumina chroma-

(25) Compound **8-exo** has been reported.¹⁸ The synthesis was slightly modified, working at room temperature instead of 40°C . Our assignment of the ^1H and ^{13}C NMR spectra for **8-exo** differs from that already published.¹⁸ [^1H NMR (C_6D_6): 1.04 (d, 9.9, H1_{anti}), 2.88 (d, 6.6, H1_{syn}), 3.95 (ddd, 6.8, 8.4, 9.6, H2), 1.28 (dd, 5.5, 8.3, H3), 9.50 (d, 5.5, H4), 1.37 (s, Cp^*), 7.10 (m), 7.25 (t, ~ 7.80), 7.32 (t, ~ 7.80), 7.85 (dd, 1.25, 5.50), 8.01 (dd, 7.18)]. ^{13}C NMR (C_6D_6): 48.1 (C1), 84.0 (C2), 60.7 (C3), 197.4 (C4), 94.4 and 94.7 (PhCCPh), 95.1 (Cp^*C), 10.0 (Cp^*Me), 127.3, 127.6, 128.9, 131.1, 131.7, 132.2, 132.9 (PhCCPh). Compound **8-exo** in C_6D_6 at 45°C and after 17 h shows, through ^1H NMR, transformation to compound **6** in a 1:0.15 ratio, respectively. After 2 days, complete conversion of compound **6** is observed. Under the same conditions, compound **8-exo** in the presence of CDCl_3 reacts faster, giving compounds **6** and **3** in a 1:0.35 ratio (17 h), without clear evidence of **8-exo**, and after 2 days the ratio changes to 1:0.5.

(26) Baya, M.; Buil, M. L.; Esteruelas, M. A.; Oñate, E. *Organometallics* **2004**, *23*, 1416.

Table 4. ^{13}C NMR Data^a for Compounds **6–8**, **10**, and **12–18**

compound	C1	C2	C3	C4	C5	C6	C(Cp*)	C(Me,Cp*)	Ph or CO, OMe
6	59.6 ^b	102.4	94.0	85.2	61.4	199.0	91.1	9.6	143.5; 141.0; 131.2 129.5; 128.0; 125.0
	59.6 ^c	102.8	94.6	85.7	61.6	200.6	91.4	10.1	143.1; 140.5; 131.0 129.3; 128.6; 128.0 127.9; 124.0
7	152.3 ^b	151.9	48.0	72.8	48.9	211.3	98.5	9.6	151.6; 142.5; 130.6 129.4; 128.7; 127.7 125.1; 124.1
8-endo	49.3 ^b	97.5	58.9	187.0	96.6		95.5	9.2	131.8; 130.9; 128.4; 128.1
	50.1 ^c	98.1	59.0	188.2	94.5 ^d	96.5 ^d	96.2	10.0	131.9; 131.1; 128.8; 127.3; 127.0; 126.8
10^e	148.5 ^b	140.0	49.9	74.1	56.8	205.3	96.5	9.4	135.1, 134.5; 130.6 130.2; 128.7; 127.7 126.3, 125.9
12	90.0 ^c	91.2	85.5	75.6	73.2	13.0	89.6	11.1	137.6; 136.3; 131.7 128.7; 127.5; 125.9 125.2; 123.4
13^f	59.3 ^b	102.8	97.0	95.1	60.1	204.4	90.9	9.2	144.7; 142.3; 131.5 129.9; 124.1
14^g	59.5 ^b	103.4	97.0	96.1	59.9	204.5	91.3	9.3	145.7; 144.5; 142.5 142.0; 131.6; 130.1 130.0; 129.9; 129.2 127.3; 126.8
15^h	58.1 ^b	102.0	102.2	87.2	60.6	204.5	91.0	9.8	145.3; 142.4; 131.8 129.6; 128.6; 128.3 127.8; 124.1
16ⁱ	43.9 ^b	98.1	95.6	95.1	58.9	203.4	93.5	8.7	174.3, 171.3 (C=O); 52.5, 50.6 (OMe)
17^j	44.5 ^b	96.3	95.9	96.0	57.8	203.6	94.4	8.9	174.2, 170.9, 168.9, 165.7 (C=O) 52.8, 52.4, 51.6, 50.9 (OMe)
	47.1 ^c	97.4 (C), 25.2 (Me)	91.6	95.7 (C), 51.0 (CH ₂)	56.0	210.0	89.4	9.8	43.1 (C7); 33.6 (C8) 31.3 (C8) ^d ; 26.4 (C8'') ^d 43.1 (C7); 33.6 (C8) 30.9 (C8') ^d ; 26.0 (C8'') ^d

^a δ (ppm); n.o. = not observed. ^b C₆D₆. ^c CDCl₃. ^d Assignment could be reversed. ^e 61.1, 51.1, stilbene carbon atoms. ^f 19.7 (C7), 33.2 (C8). ^g [C(7): 44.3 (CH₂), 138.4 (C), 127.3 (CH)], 33.2 (C8). ^h 25.3 (C7), 30.5 (C8). ⁱ 19.0 (C7), 32.5 (C8). ^j [C(7): 37.7(CH₂), 150.5 (C), 121.6(CH)], 32.5 (C8).

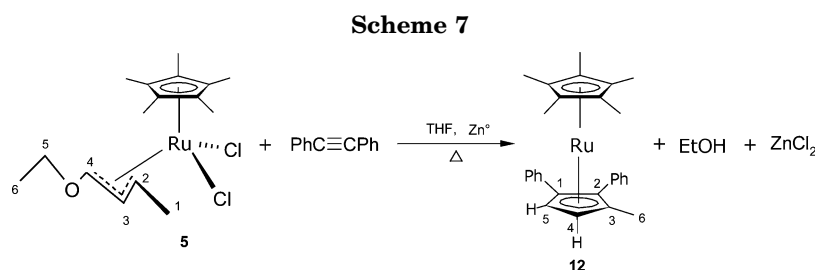
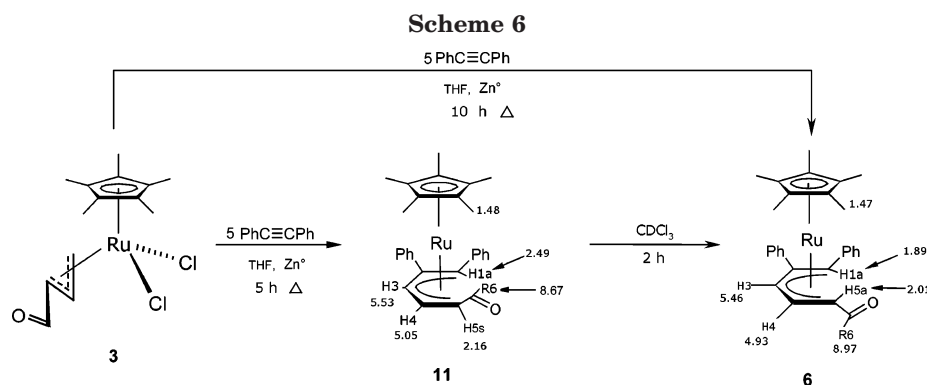

tography, affording compound **6** in 15% yield. The same reaction described in Scheme 6 but after 10 h gave basically compound **6** in 20% yield. Even though **6** is the major compound in this reaction, its purification was not quite efficient in the presence of zinc, so it was better to isolate compound **6** from the reaction of compound **1** with diphenylacetylene.

(c) Reaction of Cp*Ru[1-3- η -endo-syn-(Me)CH-CHCH(OEt)]Cl₂ (5**) with Diphenylacetylene.** The reaction between **5** and excess of diphenylacetylene (**1**: **5**) in the presence of activated zinc under reflux of THF for 8 h furnished an evident change of color, from orange

to a dark brown-yellow solution, Scheme 7. The crude of the reaction showed the presence of ethanol and Cp*Ru[η^5 -C(Ph)C(Ph)C(Me)CHCH] (**12**) by ¹H NMR. After chromatography on neutral alumina, and using hexane as eluent, some white crystals were isolated as a mixture of compound **12** and diphenylacetylene. The solubility of both compounds did not allow their separation. However, it was easy to establish the corresponding characterization of **12** by ¹H and ¹³C NMR (Tables 2 and 4). Similar structures have been obtained by [3+2] cycloaddition reactions for η^5 -cyclopentadienyl,^{5a} η^5 -pentamethylcyclopentadienyl,¹⁵ and η^6 -arene^{5,8} com-

Scheme 8

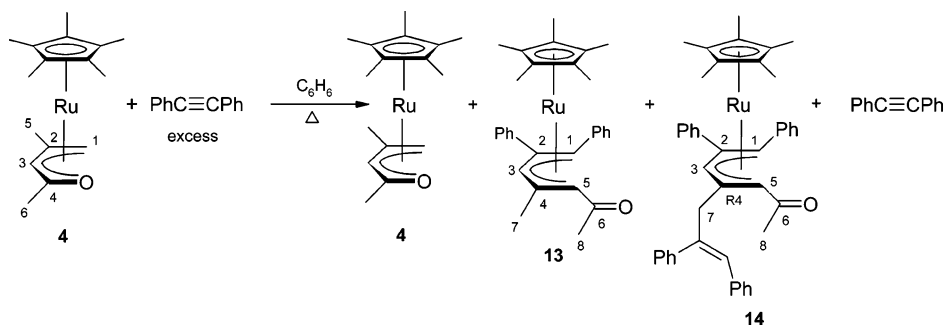

plexes of the late transition metals with several alkynes. The product of cyclization was promoted by the presence of the acetal group in compound **5**.

A tentative mechanism of reaction is the formation of ZnCl_2 and the coordination of $\eta^2\text{-PhC}\equiv\text{CPh}$ followed by the insertion of the alkyne to give a σ,π -vinyl olefin. Then, the activation of a C–H bond forms a σ -vinyl, η^3 -allyl hydride Ru(IV) complex, which will afford the 1,2-diphenyl-3-methyl-5-ethoxy- η^5 -pentadienyl ligand coordinated to a $\text{Cp}^*\text{Ru(II)}$ fragment. The formation of ethanol from the ethoxy group and one hydrogen atom of the pentadienyl ligand affords the corresponding cyclopentadienyl-substituted compound **12**.

(d) Reactions of $\text{Cp}^*\text{Ru}[\eta^5\text{-CH}_2\text{C(Me)CHC(Me)O}]$ (4**) with Diphenylacetylene and Dimethyl Acetylenedicarboxylate.** Novel functionalized yellow air-stable pentadienyl complexes were obtained from the reaction of **4** with diphenylacetylene, and it was possible to isolate the coupling and the double-coupling reaction products **13** and **14**, respectively, Scheme 8.

Upon variation of the complex **4**/diphenylacetylene ratio, it was found that a 3-fold excess of diphenylacetylene was necessary in order to achieve a better yield of **13**. However, it is also interesting to mention that the neutral alumina (Brockmann, Activity I) plays an important role in the chromatographic treatment, affording different results if it is deactivated previously (5% w/w N_2 -saturated water)²⁰ or not. Then, we extensively varied the amount of the alkyne used, time of the reaction, and the type of chromatographic support, to obtain more information on this reaction system. Under similar conditions of stoichiometry and time (1:3 ratio, 21 h), it was observed that neutral alumina, without any treatment, afforded compound **13** in 48% yield, whereas deactivated alumina improved the yield to 85.4% yield. Also, when using the latter, it was possible to avoid the formation of isomer **15** (vide infra).

The ^1H NMR of the crude of the reaction of **4** and excess diphenylacetylene showed the presence of compounds **4**, **13**, and traces of **14**, as well as diphenylacetylene. After chromatography with neutral activated alumina, the isolation of three different fractions gave compounds **13**, **14**, and **15**, respectively, which could be purified by TLC techniques.

The spectral data (Tables 2 and 4) show that complex **15** is the isomer of **13**, where only the H5 of **13** is exchanging positions (Table 2). It is interesting to compare these isomers to the analogous **11** and **6**. Whereas the *anti*-isomer **11** can easily interconvert into the thermodynamically more stable *syn*-isomer **6**, the 2,4-dimethyl-substituted complex **4** can be directly

Scheme 9

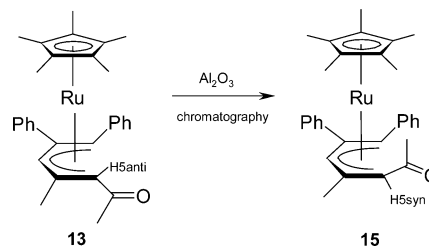

transformed into the *syn*-isomer **13**, and only in the presence of activated neutral alumina is it partially transformed to the *anti*-isomer **15**, Scheme 9. Apparently, this is because of the different steric environments of **1** and **4**. With a methyl group at carbon atom C4, the repulsion of the carbonyl substituent can interconvert to the *anti* position to give more relief to the structure.²⁷ Differentiation between the *syn* and *anti* isomers was derived from the chemical shifts of the terminal protons of the pentadienyl ligand, H1_{anti} and H5, in compounds **13** [H1_{anti}: 2.49 (s); H5_{anti}: 1.03 (s)] and **15** [H1_{anti}: 3.73 (s); H5_{syn}: 1.91 (s)] and chemical shifts and coupling constants for compounds **6** [H1_{anti}: 1.89 (s); H5_{anti}: 2.01 (t, 7.5 Hz); H4: 4.93 ($J_{4,5} = 7.8$, $J_{3,4} = 6.1$)] and **11** [H1_{anti}: 2.49 (s); H5_{syn}: 2.16 (t, 7.8 Hz); H4: 5.05 ($J_{3,4} = 6.4$, $J_{2,3} = 7.2$)] (Table 2). The $\Delta\delta = 0.60$ ppm found in compounds **6** and **11** is attributed to the diamagnetic deshielding of the carbonyl group on the H1_{anti}. Herein the crystal structure of compound **13** is reported. The crystal structure of compound **15** was also obtained; however, its poor quality established only the position of the carbonyl group (vide infra).

After 24 h, compound **13** in toluene (110 °C) or in the presence of neutral alumina in diethyl ether (room temperature) resulted in no decomposition or evidence of formation of compound **15**, whereas compound **13** in the presence of neutral alumina under reflux of toluene (6.5 h) gives evidence of compound **15**.

Compound **14** is always formed as a minor product; then, to fully characterized this compound (Tables 2 and 4), several reactions were carried out. The formation of **14** implies the activation of the C–H of the methyl group in C4 and the addition of another molecule of diphenylacetylene with the corresponding carbon–carbon bond formation, which affords a new, highly

(27) The crystal structure of $\text{Cp}^*\text{Ru}[1\text{-}5\text{-}\eta\text{-anti-CH}(\text{COOMe})\text{C}(\text{COOMe})\text{CHC}(\text{Me}_3)\text{CH}(\text{COCMe}_3)]$ also gave evidence of the exclusive preference of an *anti* conformation of the COCMe_3 group in the pentadienyl ligand. The centroid distances for $\text{Cp}^*\text{-Ru}$ and pentadienyl–Ru are 1.855 and 1.623 Å, respectively, and the dihedral angle formed by LSQ-planes is 1.06°. Ramirez-Monroy, A.; Sánchez-Castro, M. E.; Paz-Sandoval, M. A. Unpublished results.

Scheme 10

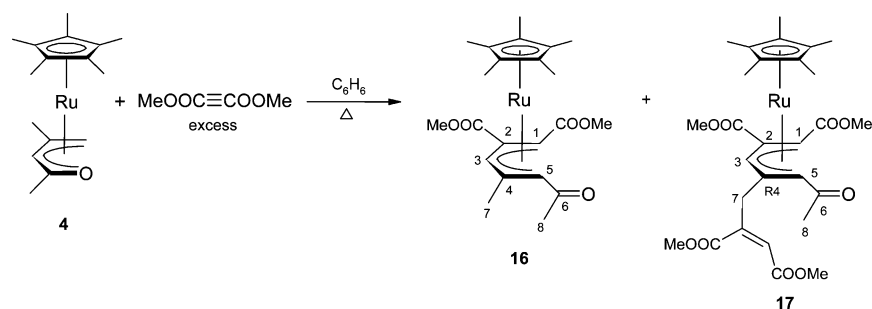

Scheme 11

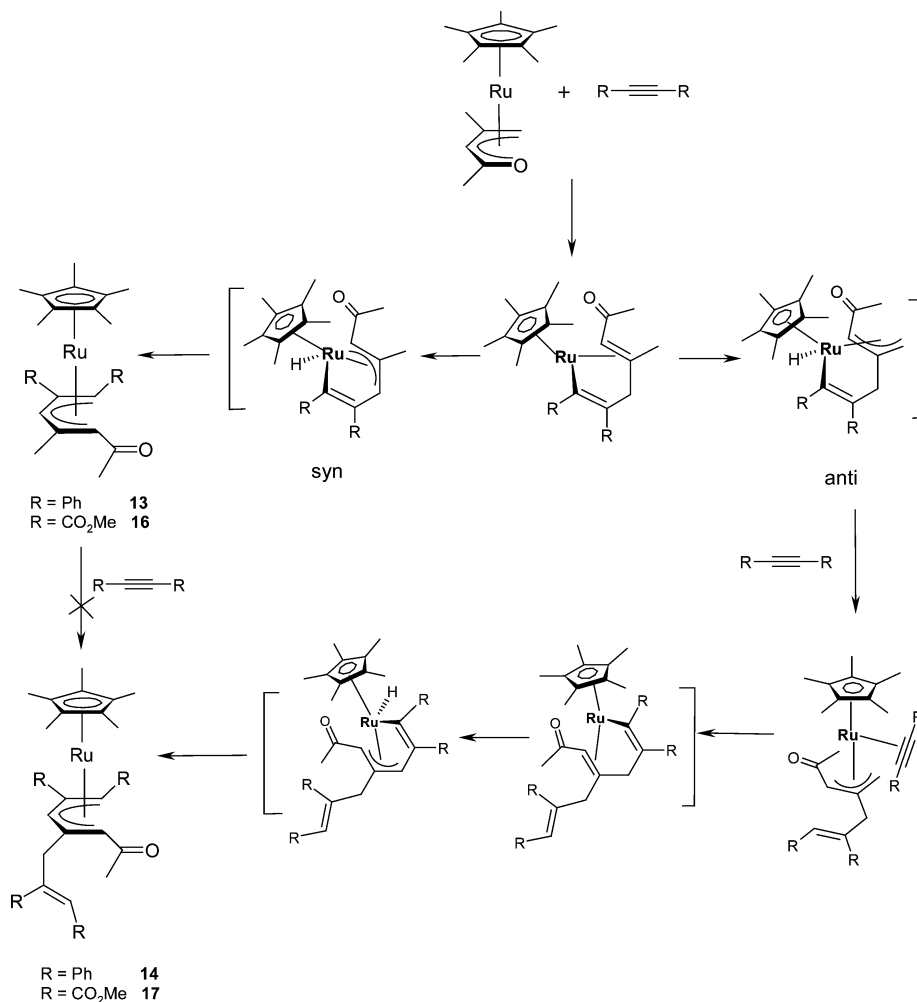

substituted pentadienyl ligand coordinated to the Cp^*Ru fragment.

An attempted synthesis of the hydrocarbon pentadienyl analogue of **13** was unsuccessful. $\text{Cp}^*\text{Ru}(2,4\text{-dimethyl-}\eta^5\text{-pentadienyl})$ did not react with diphenylacetylene, even under different and stronger conditions than those described for compound **4**. The presence of the oxygen atom in the oxopentadienyl complex **4** is determinant in the reactivity toward diphenylacetylene, which favors the attack of the alkyne at the methylene terminal carbon atom. This is due to the higher electronegativity on the oxygen compared to the homogeneous electronic environment found in the pentadienyl complex.

Similar to the synthesis of **13** and **14**, compounds **16** and **17** were prepared by treating **4** with more electron-

poor alkyne dimethyl acetylenedicarboxylate ($\text{MeO}_2\text{CC}\equiv\text{CCO}_2\text{Me} = \text{DMAD}$) in a 1:3 ratio, Scheme 10, Tables 2 and 4. The reaction is not selective, and in the presence of excess DMAD, compound **17** is favored (30% yield) compared to **16** (13% yield), which contrasts with the chemistry described for **13** and **14**. To avoid the formation of more products during the chromatography, deactivated neutral alumina was always used in the purification of these complexes, and in fact, the formation of an analogue isomer, such as **15** in the reaction of **4** with the DMAD alkyne, was not observed.

Possible reaction sequences for the formation of compounds **13**, **14**, **16**, and **17** are shown in Scheme 11.

A tentative mechanism via an unsaturated σ,π -vinylidene intermediate is proposed, which depending on the formation of Ru(IV) complexes with a *syn* or *anti*

Table 5. X-ray Data Collection Parameters for Compounds 6, 9, 13, 14, 17, and 18

	6	9	13	14	17	18
formula	C ₂₈ H ₃₀ ORu	C ₄₂ H ₄₀ ORu	C ₃₀ H ₃₄ ORu	C ₄₄ H ₄₄ ORu	C ₂₈ H ₃₆ O ₉ Ru	C ₂₂ H ₃₂ ORu
fw	483.59	661.85	511.64	689.86	617.64	413.55
cryst syst	monoclinic	triclinic	monoclinic	monoclinic	trigonal	monoclinic
space group	<i>Cc</i>	<i>P1</i>	<i>P21/n</i>	<i>P21/c</i>	<i>R3</i>	<i>P21/c</i>
<i>a</i> (Å)	12.0777(3)	9.8991(10)	16.7107(4)	10.9164(3)	44.0085(5)	7.5664(15)
<i>b</i> (Å)	11.3100(3)	10.9444(10)	7.5123(2)	17.8403(6)	44.0085(5)	13.433(3)
<i>c</i> (Å)	16.7043(5)	17.9392(10)	20.7493(6)	18.6151(5)	8.69690(10)	20.191(4)
α (deg)	90	74.28(2)	90	90	90	90
β (deg)	100.6340(1)	82.94(2)	101.9560(1)	106.395(2)	90	98.97(3)
γ (deg)	90	69.57(2)	90	90	120	90
<i>V</i> (Å ³)	2242.60(11)	1752.3(3)	2548.27(12)	3477.91(18)	14587.1(3)	2027.1(7)
<i>Z</i>	4	2	4	4	18	4
cryst size (mm)	0.3 × 0.1 × 0.1	0.3 × 0.1 × 0.1	0.2 × 0.1 × 0.1	0.1 × 0.1 × 0.03	0.3 × 0.1 × 0.1	0.3 × 0.2 × 0.1
<i>D</i> _{calc} (g cm ⁻³)	1.432	1.325	1.334	1.318	1.266	1.355
temp (K)	198	253	253	203	208	203
diffractometer	Kappa CCD	Enraf-Nonius CAD4	Kappa CCD	Kappa CCD	Kappa CCD	Kappa CCD
2 θ (max) (deg)	54.96	50.94	54.98	52.06	54.98	55.30
no. of reflns colld	10278	6497	21215	17034	44857	16275
no. of indpt reflns	4471	6497	5819	6775	7399	4672
no. of indpt obsd (4 σ) on <i>F</i> ²	4148	2589	4072	4983	5552	3174
params	268	420	308	580	373	257
final <i>R</i> ₁ ^a	0.0443	0.0493	0.0504	0.0448	0.0458	0.0388
final <i>wR</i> ₂ ^a	0.1118	0.1038	0.0950	0.0793	0.1102	0.0748
GOOF	1.083	0.886	1.054	1.101	1.089	1.009

^a $R_1 = \sum ||F_o| - |F_c|| / \sum |F_o|$; $wR_2 = [\sum w(F_o - F_c)^2 / \sum wF_o^2]^{1/2}$ are given for observed data.

orientation of the carbonyl group of the oxodienyl ligand will afford the single or double alkyne coupling reactions, respectively. At first stage, there is no evidence of a Cp^{*}Ru(2,4-dimethyl- η^3 -oxodienyl)(η^2 -alkyne) as reactive intermediate (see compounds **8-endo**, **8-exo**, vide supra), and a direct coupling of the alkyne to the oxopentadienyl coordinated ligand is proposed. Also, it should be mentioned that apparently **13** is not a precursor of **14**, since heating **13** with diphenylacetylene in a 1:3 ratio (65–70 °C for 135 h) results in no evidence of the double-coupling reaction.

It is important to mention that purification of all compounds is complicated, because even though different chromatographic procedures with different kinds of supports were carried out, several products were obtained. Instead of being purified, they always were transformed.

Attempts to react compound **4** with bis-trimethylsilylacetylene and phenylacetylene had limited success. The former did not react presumably due to the steric bulk on the SiMe₃ groups, and the latter showed that the presence of an acidic hydrogen reacts smoothly, but without any selectivity, making the isolation of the different coupling products from the reaction mixture difficult.

(e) Reaction of (Cp^{*}RuCl)₄ with Lithium Oxopentadienide to Afford Cp^{*}Ru[η^5 -CH₂C(Me)CHC(Me)O] (4) and Cp^{*}Ru[1-5- η -CH₂C(Me)CHC{CH₂C(Me)₂CH₂CO}CH] (18). In our own earlier studies, we published an improved route to synthesize Cp^{*}Ru(2,4-dimethyl- η^5 -oxopentadienyl) (**4**).²⁸ The oxopentadienyl compound **4** was formed, at -78 °C, from the corresponding lithium oxopentadienide and (Cp^{*}RuCl)₄ in 80% yield. The purification was carried out extracting the product with hexane, and the resulting solution was concentrated and chromatographed on a neutral alumina column (5 × 1.5 cm) with a mixture of hexane/diethyl ether (8:2) as the eluant. Now, running the same

experiment but extracting with diethyl ether instead of hexane, a yellow diethyl ether solution was obtained and purified through chromatographic separation on a 25 × 1.5 cm neutral alumina column. After elution with an 8:2 mixture of hexane/diethyl ether, a yellow band corresponding to compound **4** was collected, and then, a second yellow band, eluted with diethyl ether, afforded Cp^{*}Ru[1-5- η -CH₂C(Me)CHC{CH₂C(Me)₂CH₂C(O)-CH}] (**18**) as a yellow solid in a poor yield and always in the presence of the less polar compound **4**. Attempts to separate these products, **4** and **18**, were unsuccessful. However, when the mixture of **4** and traces of **18** was reacted in the presence of diphenylacetylene, **4** was practically consumed to give **13**, and **18** remained without any transformation. Purification of **18** is described in the Experimental Section, being isolated from the reaction of compound **4** with diphenylacetylene. A tentative mechanism may involve the reaction of lithium oxopentadienide with mesityl oxide to give the corresponding unsaturated enone, which in the presence of LDA and (Cp^{*}RuCl)₄ affords the interesting chiral compound **18**. To probe if the stoichiometry could afford compound **18** in higher yields, the reaction of (Cp^{*}RuCl)₄ was carried out in excess lithium oxopentadienide (1:2, respectively) with basically the same results obtained with the stoichiometric ratio.

Structural Studies of Compounds 6, 9, 13, 14, 17, and 18. The single and double alkyne coupling products can be further assessed with the aid of the X-ray crystal structure, as it will be shown for the diphenylacetylene derivatives **6**, **9**, **13**, and **14** and for the DMAD in the case of **17**. Crystal data for compounds **6**, **9**, **13**, **14**, **17**, and **18** are provided in Table 5.

The structures of **6** and **13** are presented in Figures 1 and 2. Some relevant data are provided in Table 6.

The solid-state structures from a second coupling reaction of alkynes in half-open ruthenocenes are **9**, **14**, and **17**. They are presented in Figures 3–5, while various bonding parameters are included in Tables 7 and 8. Compound **18** is shown in Figure 6, and selected data are provided in Table 9.

(28) Navarro-Clemente, M. E.; Juárez-Saavedra, P.; Cervantes-Vásquez, M.; Paz-Sandoval, M. A.; Arif, A. M.; Ernst, R. D. *Organometallics* **2002**, *21*, 592.

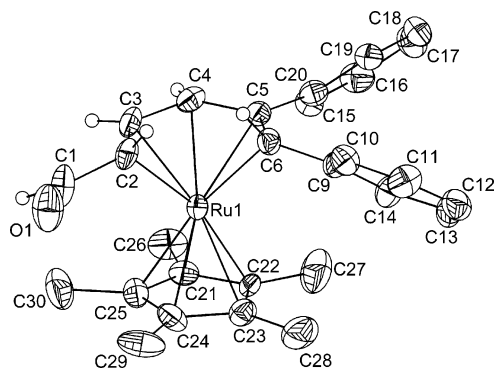

Figure 1. Perspective view of compound **6**. Most hydrogen atoms are omitted for clarity.

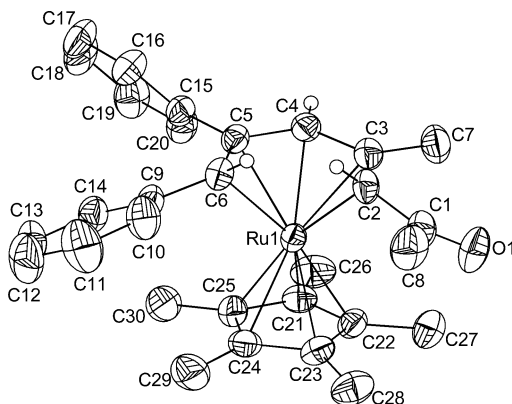

Figure 2. Perspective view of compound **13**. Most hydrogen atoms are omitted for clarity.

Table 6. Selected Bond Lengths (Å) and Bond Angles (deg) for Compounds 6 and 13

	bond distances		bond angles		
	6	13	6	13	
C1–O1	1.214(9)	1.222(5)	O1–C1–C2	125.4(5)	125.4(4)
C1–C2	1.452(9)	1.477(6)	C3–C2–C1	116.7(6)	126.1(4)
C2–C3	1.417(9)	1.429(6)	C4–C3–C2	126.4(5)	118.9(3)
C3–C4	1.435(9)	1.416(5)	C5–C4–C3	125.4(5)	128.7(4)
C4–C5	1.432(8)	1.442(5)	C6–C5–C4	118.7(6)	121.7(3)
C5–C6	1.433(8)	1.425(5)	C4–C5–C15	116.5(5)	114.5(3)
Ru1–C2	2.229(5)	2.216(4)	C6–C5–C15	124.7(5)	123.8(3)
Ru1–C3	2.144(6)	2.163(4)	C1–C2–Ru1	119.1(5)	118.1(3)
Ru1–C4	2.203(5)	2.176(4)	C15–C5–Ru1	131.2(4)	131.2(3)
Ru1–C5	2.213(6)	2.203(4)	C9–C6–Ru1	124.3(4)	121.9(3)
Ru1–C6	2.255(5)	2.238(4)	C4–C3–C7		117.9(4)
C1–C8		1.505(6)	C2–C3–C7		123.3(3)
C3–C7		1.521(5)	C7–C3–Ru1		128.6(3)
C5–C15		1.507(5)	O1–C1–C8		120.2(4)
C6–C9	1.482(7)	1.491(5)	C2–C1–C8		114.4(4)

All these compounds, except **9**, have shown that highly modified pentadienyl ligands can be obtained (*vide supra*). The structural parameters for **6**, **13**, **14**, and **17** correspond, in general, fairly closely to each other. In fact, the Ru–C6 bond distance in **14** is that which sticks out, and it is longer (2.272(4) Å) than those of **6**, **13**, or **17** (e.g., Ru–C6 = 2.255(5), 2.238(4), and 2.216(3) Å, respectively). This may reflect a greater steric problem in accommodating the phenyl ligands, as opposed to either a single coupling product in **6** and **13** or the DMAD ligand in **17**. Each complex contains an η^5 -pentadienyl ligand, coordination preferentially being observed through carbon atoms rather than through an oxopentadienyl ligand which should have an oxygen atom in the delocalized fragment. This is expected on the basis of the soft nature of Ru(II), and it is consistent

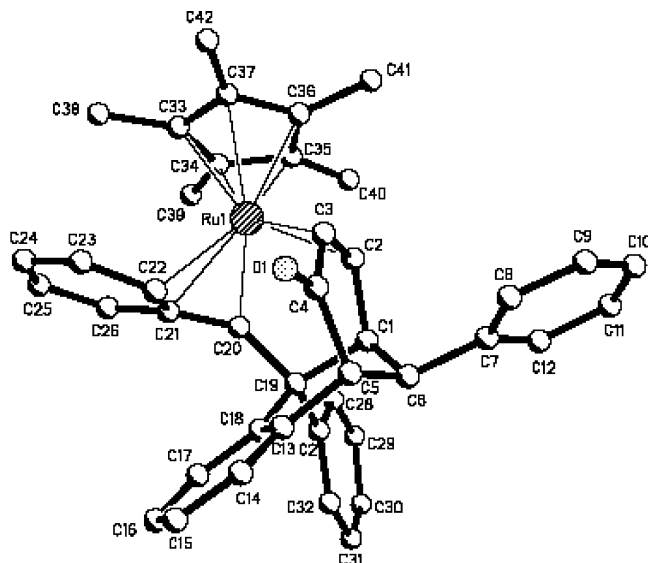

Figure 3. Crystal structure of compound **9**. Hydrogen atoms and solvent are omitted for clarity.

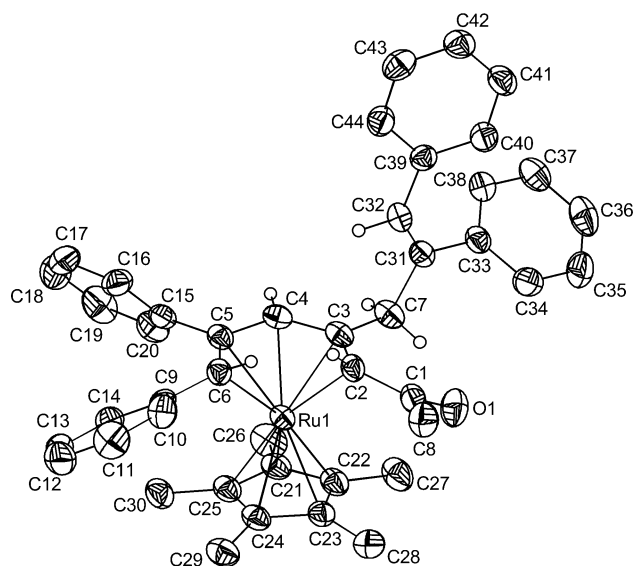

Figure 4. Perspective view of compound **14**. Most hydrogen atoms are omitted for clarity.

with previous observations.^{28,29} The CHO and COME groups in the acyclic ligands of complexes **6**, **13**, **14**, and **17** display a typical C=O bond length between 1.214(9) and 1.222(5) Å, along with significant shortening of the C1–C2 bond [1.452(9), 1.477(6) Å] compared to 1.521(5), 1.509(5), or 1.530(5) Å for C3–C7 of compounds **13**, **14**, and **17**, respectively.

Dihedral angles formed by least-squared planes with acyclic substituted pentadienyl ligands have reasonable planar structures with maximum deviations for the metal-bound atoms of 3.11°, 2.77°, 1.64°, 3.13°, and 1.90° for compounds **6**, **13**, **14**, **17**, and **18**, respectively. It is interesting to observe that while most steric demand is presented by methyl or phenyl substituents in the acyclic ligand, less deviation of the planarity was found for compounds **6** and **13** and compounds **13** and **14**, as well for Cp*Ru[1–5- η -anti-CH(COOMe)C(COOMe)CHC-

(29) (a) Benyunes, S. A.; Day, J. P.; Green, M.; Al-Saadoon, A. W.; Waring, T. L. *Angew. Chem., Intl. Ed. Engl.* **1990**, *29*, 1416. (b) Trakarnpruk, W. Ph.D. Thesis, University of Utah, 1993.

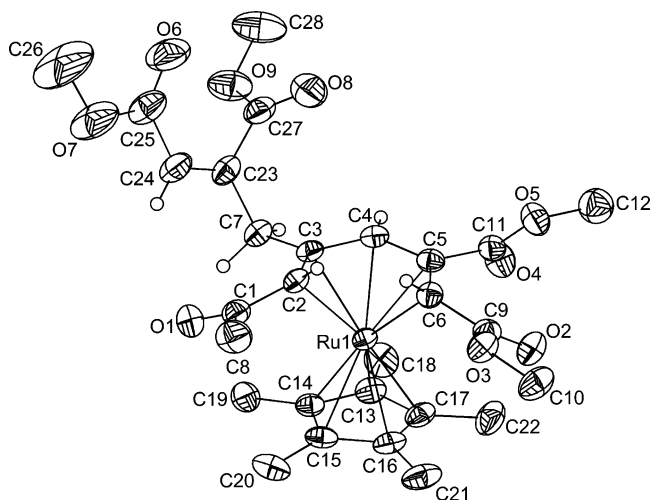

Figure 5. Perspective view of compound **17**. Most hydrogen atoms are omitted for clarity.

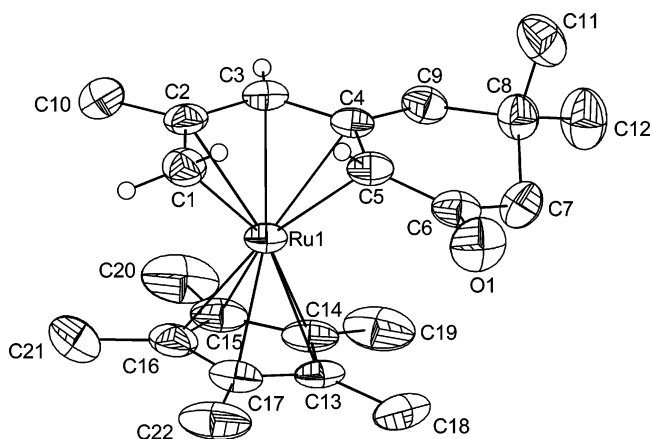

Figure 6. Perspective view of compound **18**. Most hydrogen atoms omitted for clarity.

Table 7. Selected Bond Lengths (Å) and Angles (deg) for Compound 9

bond lengths		bond angles	
C1–C2	1.520(8)	C2–C1–C6	108.4(5)
C2–C3	1.409(8)	C2–C1–C19	113.2(5)
C3–C4	1.452(8)	C6–C1–C19	111.4(5)
C4–O1	1.226(7)	C3–C2–C1	118.9(5)
C4–C5	1.566(8)	C3–C2–Ru1	74.7(4)
C5–C6	1.515(9)	C1–C2–Ru1	117.6(4)
C6–C7	1.536(9)	C2–C3–C4	121.2(6)
C1–C6	1.545(8)	C2–C3–Ru1	67.2(3)
C1–C19	1.565(8)	C4–C3–Ru1	129.0(4)
C18–C19	1.526(7)	O1–C4–C3	123.5(6)

(CMe₃)CH(COCMe₃)).²⁷ This is not the case for the dimethyl acetylenedicarboxylate double-coupling derivative **17**. Although the Ru–C distances for the Cp* and pentadienyl ligands of **6**, **13**, **14**, **17**, and **18** are rather similar, the metal atom is located closer to the acyclic group, 1.859 and 1.648 Å (average values for Cp* and pentadienyl distances, respectively), which is expected according to the wider acyclic pentadienyl ligand.²² The difference of the average values $\Delta = 0.211$ is even shorter than that corresponding to half-open ruthenocenes Cp*Ru(3-methyl- η^5 -pentadienyl) (1.567 vs 1.834 Å; $\Delta = 0.267$)²² and Cp*Ru(2,4-dimethyl- η^5 -pentadienyl) (1.611 vs 1.836 Å; $\Delta = 0.225$),³⁰ which reflects the longer

(30) Ramirez-Monroy, A.; Sánchez-Castro, M. E.; Cervantes Vásquez, M.; Aleman Figueroa, I. R.; Paz-Sandoval, M. A. Unpublished results.

Table 8. Selected Bond Lengths (Å) and Bond Angles (deg) for Compounds 14 and 17

	bond lengths		bond angles		
	14	17	14	17	
C1–O1	1.230(5)	1.224(4)	O1–C1–C2	124.5(4)	125.1(4)
C1–C2	1.476(5)	1.460(5)	C3–C2–C1	123.9(3)	126.6(3)
C2–C3	1.442(5)	1.434(5)	C4–C3–C2	120.5(3)	119.4(3)
C3–C4	1.421(5)	1.421(5)	C5–C4–C3	128.5(4)	125.9(3)
C4–C5	1.435(5)	1.436(5)	C6–C5–C4	122.4(3)	124.5(3)
C5–C6	1.423(5)	1.433(5)	O1–C1–C8	119.3(4)	119.6(4)
C1–C8	1.507(6)	1.505(5)	C2–C1–C8	116.2(3)	115.3(4)
C3–C7	1.509(5)	1.530(5)	C4–C3–C7	116.3(4)	117.3(3)
Ru1–C2	2.236(3)	2.223(3)	C2–C3–C7	123.1(4)	123.4(3)
Ru1–C3	2.164(3)	2.161(3)	C5–C6–C9	124.9(3)	119.1(3)
Ru1–C4	2.182(4)	2.184(3)	C1–C2–Ru1	119.3(2)	116.3(2)
Ru1–C5	2.207(3)	2.148(3)	C7–C3–Ru1	128.5(2)	126.9(2)
Ru1–C6	2.272(4)	2.216(3)	C9–C6–Ru1	124.8(2)	117.6(2)
C5–C15	1.497(5)		C6–C5–C11		122.5(3)
C7–C31	1.520(5)		C3–C7–C23		109.9(3)
C31–C32	1.336(5)		C4–C5–C15	114.4(3)	
C31–C33	1.487(5)		C3–C7–C31	113.8(3)	
C5–C11		1.514(5)	C6–C5–C15	123.2(3)	
C11–O4		1.198(4)	C15–C5–Ru1	130.7(2)	
C11–O5		1.331(4)	C7–C31–C32	121.3(3)	
C12–O5		1.440(5)			

Table 9. Bond Distances (Å) and Angles (deg) for Compound 18

bond lengths		bond angles	
C1–C2	1.419(5)	Ru1–C1–C2	71.01(18)
C2–C3	1.417(5)	C3–C2–C1	122.6(3)
C3–C4	1.426(5)	C4–C3–C2	127.0(3)
C4–C5	1.432(4)	C5–C4–C3	121.8(3)
C5–C6	1.453(5)	C6–C5–C4	119.3(3)
C6–C7	1.515(5)	C5–C4–C9	121.4(3)
C7–C8	1.524(5)	C3–C4–C9	116.8(3)
C8–C9	1.532(5)	O1–C6–C5	122.5(3)
C4–C9	1.523(5)	C5–C6–C7	117.8(3)
C8–C11	1.531(4)	C6–C7–C8	112.7(3)
C6–O1	1.234(3)	C7–C8–C11	110.7(3)
Ru1–C1	2.181(3)		
Ru1–C2	2.181(3)		
Ru1–C3	2.203(3)		
Ru1–C4	2.188(3)		
Ru1–C5	2.221(3)		

distances from both ligands to the ruthenium atom in the highly substituted complexes. The centroid Cp*–Ru distance of compound **6** is particularly long (1.899 Å) compared with those of the more substituted complexes **13**, **14**, **17**, and **18**, which are 1.851, 1.854, 1.851, and 1.839 Å, respectively; meanwhile the similarity of pentadienyl–Ru centroid distances is evident (1.653, 1.640, 1.648, 1.625, and 1.635 Å for compounds **6**, **13**, **14**, **17**, and **18**, respectively). Compound **18** can be compared to Cp*Ru[2-methyl-4,5-(dimethylbicyclo[3.1.1]heptane)1–5- η -pentadienyl]¹⁹ (vide supra); in general terms, it is observed that the pentadienyl fragment of **18** is more symmetric than the chiral molecule just mentioned [Ru–C_{central} = 2.203(3) vs 2.159(13)¹⁹ Å; C2–C3 = 1.417(5) and C12–C13 = 1.355(15) Å¹⁹].

The single crystal of Cp*Ru[1–5- η -syn-CH(COOMe)C(COOMe)CHC(Me)CH(COMe)] (**16**) showed two molecules in the unit cell. However, the high disorder observed led to a poor-quality structure, which was also observed for compound **15**.

Conclusions

A successful synthesis of Cp*Ru(η^5 -CH₂CHCHCHO) was achieved. Several types of substituted pentadienyl ruthenium complexes can be obtained by coupling reactions of oxodienyl ligands with diphenylacetylene

or dimethyl acetylenedicarboxylate. It was established that the formation of the new compounds depends on the presence of the oxygen heteroatom and the concentration of the alkyne. The reactions always require an excess of the alkyne, and it was found that the diphenylacetylene is more selective compared to the dimethyl acetylenedicarboxylate. A second molecule of alkyne can react through the C–H activation of the methyl substituent in compound **4** to give even more substituted pentadienyl ligands coordinated to the Cp*Ru fragment. In contrast, the allyl derivative **5** affords evidence of formation of a substituted cyclopentadienyl complex. The diphenylacetylene derivatives are very stable, whereas the dimethylacetylenedicarboxylate analogues are less stable and can be easily hydrolyzed in solution. The Cp*Ru(pentadienyl) class of compounds has proven capable of supporting a rich variety of substituted pentadienyl ligands, which include methyl, phenyl, aldehyde, acetyl, and acetate groups, which will allow a greater understanding of the electronic nature of the pentadienyl ligands.

Experimental Section

Standard inert-atmosphere techniques were used for all syntheses and sample manipulations. The solvents were dried by standard methods (hexane and pentane with CaH₂, diethyl ether and THF with Na/benzophenone, CH₂Cl₂ and CHCl₃ with CaCl₂, benzene and toluene with Na) and distilled under argon prior to use. Compounds (Cp*RuCl)₄,³¹ (Cp*RuCl₂)₂,³² Cp*Ru-(2,4-dimethyl-η⁵-oxopentadienyl),^{22,28} and Cp*Ru(2,4-dimethyl-η⁵-pentadienyl),^{22,28} were prepared according to literature procedures. All other chemicals, such as RuCl₃·*n*H₂O, zinc activated,³³ 1-(trimethylsilyloxy)buta-1,3-diene, diphenylacetylene, and dimethyl acetylenedicarboxylate, were used as purchased from Strem Chemicals, Fluka, and Sigma-Aldrich. Elemental analyses were performed at the Chemistry Department of Cinvestav with a Thermo-Finnigan Flash 112 and Desert Analytics, Tucson, AZ. IR spectra were recorded on a Perkin-Elmer 6FPC-FT spectrophotometer using KBr or CHCl₃. ¹H and ¹³C NMR spectra were recorded on JEOL GSX-270, JEOL Eclipse-400 MHz, or Bruker DPX 300 MHz spectrometers in deoxygenated, deuterated solvents. NMR chemical shifts are reported relative to TMS. Mass spectra were obtained with a Hewlett-Packard HP-5990A. Ionization was by FAB with xenon atoms at 6 keV energy (Washington University, St. Louis, MO); *m/z* values are given relative to ¹⁰²Ru. Melting points were determined using a Mel-Temp apparatus and are not corrected.

Synthesis of Cp*Ru(η⁵-CH₂CHCHCHO) (1). An orange-yellow diethyl ether/hexane (1:1) solution (2 mL) containing 200 mg of **2** (0.48 mmol) was passed through chromatographic column on neutral deactivated alumina (Brockmann I) (2.5 × 18 cm) with elution by hexane and diethyl ether. The yellow solution was evaporated and recrystallized in pentane at –15 °C, giving after 24 h canary-yellow needles with mp 92–93 °C in 67% yield (98.8 mg, 0.32 mmol). Anal. Calcd for C₁₄H₂₀ORu: C, 55.05; H, 6.60. Found: C, 54.94; H, 6.51. IR (KBr, cm⁻¹): 2951 (s), 2901 (vs), 1472 (s), 1377 (vs), 1266 (vs). MS (20 eV): *m/z* 306 (64) [M⁺], 278 (100), 236 (88).

Synthesis of Cp*Ru(1-4-η-CH₂CHCHCHOSiMe₃)Cl (2) and Cp*Ru(1-3-η-endo-syn-CH₂CHCHCHO)Cl₂ (3). To a red-brown solution of THF (25 mL) containing 650 mg of

(Cp*RuCl₂)₂ (2.1 mmol) at room temperature was added, drop by drop, a solution of CH₂CHCHCHOSiMe₃ (0.37 mL, 2.1 mmol) in THF (2 mL). The dark brown solution turned yellow-brown after 1 h, and the stirring was continued for 1.5 h. After filtration and evaporation of the solvent, the residue was washed with hexane (60 mL) and filtered, and the volume was reduced until 10 mL, precipitating bright orange needles of compound **2** at –15 °C with mp 103–105 °C in 40% yield³⁴ (350 mg, 0.85 mmol). The mustard-yellow solid, insoluble in hexane, was purified on a preparative silica gel plate, using acetone. The eluent was a mixture of ethyl acetate/acetone (8:2). The orange band was removed and extracted with acetone from the silica. Recrystallization with chloroform and hexane afforded orange-red crystals of **3**, which do not melt and decompose above 200 °C, in 56% yield (442 mg, 1.18 mmol). Compound **2**: Anal. Calcd for C₁₇H₂₉ClOSiRu: C, 49.33; H, 7.01, Si, 6.77. Found: C, 49.53; H, 7.02; Si, 7.02. IR (KBr, cm⁻¹): 2956 (m), 2910 (m), 1654 (m, br), 1250 (s), 1170 (vs), 872 (vs), 848 (s). LR FAB MS (matrix: 3-NBA/Li): *m/z* 414 (40) [M⁺], 379 (100), 364 (88). Compound **3**: Anal. Calcd for C₁₄H₂₀Cl₂ORu: C, 44.68; H, 5.30. Found: C, 44.52; H, 5.37. IR (KBr, cm⁻¹): 2968 (m), 2915 (m), 2861 (m), 1691 (vs), 1479 (m). LR FAB MS (matrix: 3-NBA/Li): *m/z* 382 (70) [M⁺ + Li], 383 (100) [M⁺ + 1 + Li].

Synthesis of Cp*Ru[1-3-η-endo-syn-(Me)CHCHCH(O-Et)]Cl₂ (5). To a brown solution of EtOH (30 mL) containing 500 mg of (Cp*RuCl₂)₂ (1.6 mmol) at room temperature was added, drop by drop, CH₂CHCHCHOSiMe₃ (0.57 mL, 3.2 mmol). The dark brown solution turned yellow-brown after 3.5 h under reflux. After filtration and evaporation of the solvent, the dark orange residue was washed, six times, with toluene (~8 mL). The pale orange complex **5**, insoluble in toluene, was recrystallized at –15 °C with chloroform/hexane as orange needles (317 mg, 0.78 mmol) with mp 169–171 °C in 48% yield. Anal. Calcd for C₁₆H₂₆Cl₂ORu: C, 47.29; H, 6.45. Found: C, 46.59; H, 6.49. IR (KBr, cm⁻¹): 2982 (m), 2908 (m), 1538 (s), 1452 (m, br), 1380 (vs), 1217 (s), 1030 (s), 853 (m, br).

Synthesis of Cp*Ru[1-5-η-syn-CH(Ph)C(Ph)CHCHCH-CHO] (6), Cp*Ru[1,4,5-η-C(Ph)C(Ph)CH₂CHCH₂](CO) (7),¹⁷ [Cp*Ru(1-3-*exo-syn-η*-CH₂CHCHCHO)(η²-PhC≡CPh)] (8-*exo*),¹⁸ [Cp*Ru(1-3-*endo-anti-η*-CH₂CHCHCHO)(η²-PhC≡CPh)] (8-*endo*), [Cp*Ru[1,6,7,10,11-η-CH(CH)₄CCHC(Ph)-CH(CH₂)C(O)CH(C₆H₄)CH(Ph)] (9), and Cp*Ru[3-5-η-C(Ph)-C(Ph)CHCHCH(O)](η²-PhCH=CHPh) (10). (a) **Reaction of 1 with Diphenylacetylene in a 1:2 Ratio. A yellow solution of **1** (150 mg, 0.49 mmol) in 30 mL of THF was under reflux, for 24 h, with 17.5 mg (0.98 mmol) of diphenylacetylene, giving a dark brown solution, which was filtered and evaporated under vacuum. Extractions with Et₂O, followed by reducing the volume to 2 mL, and adding this sample in a chromatographic column (neutral alumina, 19 × 2 cm) afforded three different fractions. The first band, eluted with hexane, was diphenylacetylene along with compound **7**. After a second chromatography of this mixture, with hexane and hexane/diethyl ether, respectively, the diphenylacetylene and compound **7** were obtained pure. **7** precipitated at –15 °C as an orange powder, in very low yield, 1.2% (3 mg, 0.006 mmol). The second band gave, after treatment with hexane/diethyl ether (1:1), compound **6** as a yellow solid at –78 °C in 35% yield (83.1 mg, 0.17 mmol). With the same mixture of solvents, yellow needles (mp 214–216 °C) were obtained from recrystallization at room temperature. The third band, using diethyl ether as eluant, afforded compound **8-endo** as yellow needles with mp 135–138 °C in 12% yield (28 mg, 0.058 mmol). Anal. Calcd for **8-endo**: C₂₈H₃₀ORu: C, 69.54; H, 6.25. Found: C, 69.21; H, 6.06. IR (KBr, cm⁻¹): 3067 (w), 2911 (w), 2858 (w), 1844 (m), 1637 (vs), 1591 (w), 1484 (m), 1025 (m), 756 (m), 692 (m). MS: 483 (80) [M⁺], 454 (100), 314 (26), 236 (26).**

(34) Compound **2** could be obtained in better yield (88%) from [Cp*RuCl]₄, without formation of compound **3**.

(31) Fagan, P. J.; Ward, M. D.; Calabrese J. C. *J. Am. Chem. Soc.* **1989**, *111*, 1698.

(32) (a) Oshima, N.; Suzuki, H.; Moro-Oka, Y. *Chem. Lett.* **1984**, 1161. (b) Tilley, T. D.; Grubbs, R. H.; Bercaw, J. E. *Organometallics* **1984**, *3*, 274.

(33) Yamamura, S.; Hirata, Y. *J. Chem. Soc. (C)* **1968**, 2887.

(b) Reaction of 1 with Diphenylacetylene in a 1:3.5 Ratio. The reaction was carried out via a procedure similar to that previously described in (a). From this reaction four different fractions were obtained from the chromatography column. The first band afforded compound **7** along with diphenylacetylene. The second band yielded **6**, **8-exo**, and diphenylacetylene, while the third and fourth bands were eluted with diethyl ether, giving compounds **8-endo** and **10**, respectively. The recrystallization with the minimum amount of diethyl ether of the second fraction of the chromatography afforded, after 3 days at room temperature, yellow (**6**; 71 mg, 0.14 mmol, 30%) and orange (**9**; few crystals) needles, which were separated manually. Compound **8-endo** was recrystallized in diethyl ether and obtained as yellow needles in 2% yield (5 mg, 0.01 mmol). Finally, the oily yellow compound **10** was again chromatographed with diethyl ether, giving after evaporation of the solvent and recrystallization with pentane at $-78\text{ }^{\circ}\text{C}$ traces of a red-brown solid with a mp $142\text{--}145\text{ }^{\circ}\text{C}$ in $\sim 3\%$ yield (10 mg, 0.15 mmol).

Synthesis of Isomers Cp*Ru[1-5- η -syn-CH(Ph)C(Ph)-CHCHCH(CHO)] (6 and 11). (a) To a stirred solution of compound **3** (60 mg, 0.16 mmol) in THF (30 mL) were added diphenylacetylene (14.22 mg, 0.79 mmol) and powdered zinc (0.1 g, 1.52 mmol). The mixture was refluxed and stirred for 5 h. During this time the reaction goes from red-orange to yellow-orange. Filtration of the reaction and evaporation of the THF gave an orange residue, which was washed with diethyl ether (10 mL), the volume was reduced under vacuum, and at $-5\text{ }^{\circ}\text{C}$ orange needles of **11** were obtained in very low yield. Mp: $182\text{--}185\text{ }^{\circ}\text{C}$. The insoluble fraction was dissolved in dichloromethane, and after chromatography on neutral alumina ($2 \times 15\text{ cm}$) and using diethyl ether as eluant, **6** was obtained in 15% yield (11.5 mg, 0.023 mmol).

(b) The reaction was carried out as described in (a), but the reflux was prolonged for 10 h, affording **6** in 20% yield (15.4 mg, 0.032). Compound **6**: Anal. Calcd for $\text{C}_{28}\text{H}_{30}\text{ORu}$: C, 69.54; H, 6.25. Found: C, 69.41; H, 6.12. IR (CHCl_3 , cm^{-1}): 3055 (w), 2899 (w), 2802 (w), 1666 (vs), 1595 (m), 1461 (m, br), 1135 (m). MS: m/z 483 (13) $[\text{M}^+]$, 236 (47).

Identification of Cp*Ru[1-5- η -C(Ph)C(Ph)C(Me)CHCH] (12). To a stirred solution of compound **5** (80 mg, 0.20 mmol) in THF (20 mL) were added diphenylacetylene (0.17 g, 0.95 mmol) and powdered zinc (64 mg, 0.98 mmol). The mixture was refluxed and stirred for 1 h. During this time the reaction goes from deep orange to dark brown. After stirring 8 h the solution is yellow-brown. Filtration of the reaction and evaporation of the THF gave an orange residue, which was washed three times (5 mL) with diethyl ether/hexane (1:1), the volume was reduced under vacuum, and the reaction mixture was treated by column chromatography in neutral alumina ($2 \times 20\text{ cm}$). Three fractions were collected, but only the first one was interesting, showing a mixture of diphenylacetylene and compound **12**. An attempt to purify **12** in a second chromatography, using hexane as eluant, was unsuccessful due to the similar solubilities of both compounds. Characterization of **12** was carried out exclusively through ^1H and ^{13}C NMR.

Synthesis of the Isomers Cp*Ru[1-5- η -CH(Ph)C(Ph)-CHC(Me)CH(COMe)] (13 and 15) and Compounds Cp*Ru[1-5- η -syn-CH(Ph)C(Ph)CHC{CH₂C(Ph)CH(Ph)}CH(COMe)] (14) and Cp*Ru[1-5- η -CH₂C(Me)CHC{CH₂-C(Me)₂CH₂CO}CH] (18). (a) **Reaction of 4 with Diphenylacetylene in a 1:1 Ratio.** A solution of **4** (248 mg, 0.74 mmol) in 25 mL of benzene at room temperature was stirred, diphenylacetylene (133 mg, 0.74 mmol) was added, and the mixture was refluxed for 33.5 h. The solution was evaporated under vacuum, and the residue was chromatographed on neutral alumina (Brockmann I). The first fraction collected with a mixture of hexane/diethyl ether (8:2) gave after evaporation compound **13** as yellow needles with mp $176\text{--}178\text{ }^{\circ}\text{C}$ in 40% yield (152.2 mg, 0.30 mmol). A second band was collected with hexane/diethyl ether (5:5) to give compound **4**.

The last yellow band eluted with diethyl ether was compound **15** along with **18**. After a second preparative alumina plate, using a mixture of hexane/diethyl ether (6:4) compounds **15** and **18** were separated. Evaporation and recrystallization from hexane/diethyl ether at $-15\text{ }^{\circ}\text{C}$ gave the amber compound **15**, mp $203\text{--}205\text{ }^{\circ}\text{C}$, in low yield, and compound **18** was obtained from diethyl ether at $-15\text{ }^{\circ}\text{C}$ as a few yellow single crystals. Compound **13**: Anal. Calcd for $\text{C}_{30}\text{H}_{34}\text{ORu}$: C, 70.42; H, 6.70. Found: C, 70.31; H, 6.90. IR (KBr, cm^{-1}): 3066 (w), 2961 (s), 2905 (s), 1660 (vs), 1596 (m). MS: m/z (70 eV) 512(12) $[\text{M}^+]$, 495(100), 469(90), 453(16), 439(12), 415(5), 377(2), 327(3), 236(7), 233(22), 178(4), 91(5), 43(73). Compound **15**: Anal. Calcd for $\text{C}_{30}\text{H}_{34}\text{ORu}$: C, 70.42; H, 6.70. Found: C, 70.15; H, 6.80. IR (KBr, cm^{-1}): 3057 (w), 2964 (s), 2905 (s), 1639 (vs), 1596 (m). MS: m/z (70 eV) 512(13) $[\text{M}^+]$, 495(100), 469(78), 453(12), 439(9), 415(4), 377(1), 314(2), 236(4), 43(2).

(b) Reaction of 4 with Diphenylacetylene in a 1:3 Ratio. A solution of **4** (200 mg, 0.60 mmol) in 25 mL of benzene at room temperature was stirred. Then, diphenylacetylene (321 mg, 1.8 mmol) was added and the mixture was refluxed for 21 h. The solution was evaporated under vacuum, and the residue was chromatographed on deactivated neutral alumina.²⁰ The use of hexane as eluant allows removal of the excess diphenylacetylene, and compound **13** was then collected from the column ($20 \times 1.5\text{ cm}$) with a mixture of hexane/diethyl ether (8:2) as the eluant. A yellow band was collected. The solvent was reduced and the product crystallized from diethyl ether at room temperature to give 262 mg (0.51 mmol, 85.4%) of **13** as a yellow crystalline powder. Compound **14** was obtained in traces (see text) as a yellow powder with a melting point of $235\text{--}238\text{ }^{\circ}\text{C}$ (dec). Compound **14**: Anal. Calcd for $\text{C}_{44}\text{H}_{44}\text{ORu}$: C, 76.60; H, 6.43. Found: C, 77.23; H, 6.45. MS: m/z 690(5) $[\text{M}^+]$, 673(100), 667(14), 647(20), 556(6), 497(10), 454(46), 436(14), 429(10), 415(18), 363(6), 338(9), 261(9), 243(9) 236(5), 193(4), 44(5).

(c) Interconversion of Compound 13 into Isomer 15. A stirred solution of **13** (50 mg, 0.098 mmol) and 1.5 g of alumina (Brockmann I) in 25 mL of toluene was refluxed for 6.5 h. The solution was filtered and the alumina washed with acetone. The solvent was evaporated under vacuum, and the residue (product distribution was determined by ^1H NMR in a ratio 2.8:2.5:4.7 for **13**, **15**, and unknown compound, respectively) was chromatographed on neutral alumina (Brockmann I) eluted with pentane/diethyl ether (1:1). The first fraction gave a mixture of **13** along with the major unknown compound [δ , ^1H NMR (C_6D_6): 1.38 (s, 15H), 1.54 (s, 3H), 2.52 (s, 3H), 0.96 (s, 1H), 4.92 (s, 1H), 5.92 (s, 1H), 6.20 (d, $J = 7.67\text{ Hz}$, 1H), 6.98, 7.12, and 7.39 (Ar-H)]. A second yellow band was collected, giving after evaporation compound **15** as yellow powder.

Synthesis of Cp*Ru[1-5- η -syn-CH(COOMe)C(COOMe)-CHC(Me)CH(COMe)] (16) and Cp*Ru[1-5- η -syn-CH(COOMe)C(COOMe)CHC{CH₂C(COOMe)CH(COOMe)}-CH(COMe)] (17). A solution of **4** (200 mg, 0.60 mmol) in 25 mL of benzene at room temperature was stirred. Then, dimethyl acetylenedicarboxylate (0.22 mL, 1.8 mmol) was added and the mixture was refluxed for 22 h. The solution was evaporated under vacuum, and the residue was chromatographed on neutral alumina (Brockmann I). The first fraction collected with a mixture of hexane/diethyl ether (2:8) gave, after evaporation and recrystallization in diethyl ether, the amber compound **16**, which has a mp $178\text{--}180\text{ }^{\circ}\text{C}$, in 13% yield (37.0 mg, 0.08 mmol). A second yellow band was collected from diethyl ether, giving, after evaporation and recrystallization from hexane/diethyl ether at $-78\text{ }^{\circ}\text{C}$, compound **17** as yellow needles with mp $128\text{--}130\text{ }^{\circ}\text{C}$ in 30% yield (111.1 mg, 0.18 mmol). Anal. Calcd for **16**, $\text{C}_{22}\text{H}_{30}\text{O}_5\text{Ru}$: C, 55.57; H, 6.36. Found: C, 55.82; H, 6.69. IR (KBr, cm^{-1}): 3071 (w), 2954 (s), 2908 (s), 1728 (vs), 1705 (vs), 1663 (vs), 1439 (vs, br). MS: m/z 476(17) $[\text{M}^+]$, 459(100), 431(4), 401(22), 385(6), 373(15), 264(25), 236(72), 179(33), 149(11), 105(8), 91(15), 77(15), 59(15),

43(94). Anal. Calcd for **17**, C₂₈H₃₆O₉Ru + EtOEt: C, 55.56; H, 6.70. Found: C, 55.53, H, 6.31. IR (KBr, cm⁻¹): 3431 (w, br), 2987 (w), 2953 (s), 2910 (s), 1717 (vs, br), 1651 (vs), 1438 (vs, br). MS: *m/z* 618(12) [M⁺], 601(86), 587(4), 543(13), 527(4), 515(4), 485(4), 455(4), 429(6), 397(3), 339(3), 289(5), 264(18), 236(61), 203(9), 43(100).

X-ray Structure Determination of Compounds 6, 9, 13, 14, 17, and 18. Single crystals of compounds **6**, **9**, **13**, **14**, **17**, and **18** were mounted on glass fibers. X-ray data were collected on Enraf Nonius Kappa CCD or CAD4 diffractometers, using graphite-monochromated Mo K α radiation ($\lambda = 0.71073$ Å) at low temperature. Structure solution and refinement were carried out using SHELXS-97³⁵ included in the package Wingx.³⁶ The ruthenium positions were determined by the Patterson method. The remaining non-hydrogen atoms were found by successive full-matrix least-squares refinement and difference Fourier map calculations. In general, non-hydrogen atoms were refined anisotropically, while hydrogen atoms were placed at idealized positions. Absorption correction was applied for all compounds. Data collection parameters and structure

(35) Sheldrick, G. M. *SHELXL*, Program for Crystal Structure Refinement; University of Göttingen: Göttingen, Germany, 1998.

(36) Farrugia, L. J. *J. Appl. Crystallogr.* **1999**, *32*, 837

refinement details are summarized in Table 5. Compound **9** has a disorder molecule of diethyl ether, which is not included in the crystallographic data.

Acknowledgment. Financial support for this work was provided by Conacyt, Mexico (38507-E). M.E.S.C. and A.R.M. thank Conacyt for scholarships. We express our thanks to Dr. Angelina Flores Parra for helpful discussions and one of the referees for helpful comments and a better view of Figure 3. We thank the service of the Washington University Mass Spectrometer Resource, which is supported by the NIH Center for Research Resources. We thank Ma. Luisa Rodríguez for assistance with some NMR experiments.

Supporting Information Available: Tables of data of atomic coordinates, bond lengths and angles, anisotropic thermal parameters, and least-squares planes for compounds **6**, **9**, **13**, **14**, **17**, and **18** are given, and data for these compounds are also given in CIF format. This material is available free of charge via the Internet at <http://pubs.acs.org>.

OM0500180