

Electron Ionization Frequency in Hydrogen

WILLIAM B. COTTINGHAM

Bell Telephone Laboratories, Whippany, New Jersey

AND

S. J. BUCHSBAUM

Bell Telephone Laboratories, Murray Hill, New Jersey

(Received 27 December 1962).

The frequency of ionization by electrons in hydrogen has been measured during pulsed microwave breakdown in a waveguide. Optical radiation emanating from the plasma was used to determine the temporal rate of growth of electron density. Values of the ionization frequency are presented as a function of E_e/p_0 for $36 < E_e/p_0 < 200$ V/cm-mm Hg. The measurements constitute an extension of the work of Madan, Gordon, Buchsbaum, and Brown who measured this coefficient up to an E_e/p_0 of 40 V/cm-mm Hg by microwave cavity techniques. Comparison is made with previous dc measurements of Rose and with the theory of Allis and Brown. Good agreement is obtained with the measurements of Rose but not with the theory of Allis and Brown extended to high E_e/p_0 , nor with the previous microwave measurements of Madan *et al.*

INTRODUCTION

DIRECT measurements of the ionization frequency and the coefficient of free diffusion of electrons during microwave breakdown of hydrogen were made by Madan, Gordon, Buchsbaum, and Brown.¹ Their measurements cover a range of the ratio of effective electric field strength to pressure, (E_e/p_0), from 24 to 40 V/cm-mm Hg. Our experiments extend the measurements of the electron ionization frequency in hydrogen to E_e/p_0 between 36 and 200 V/cm-mm Hg.

A microwave cavity was employed by Madan *et al.* for the determination of the time required for the electron density to grow to a predetermined value during the breakdown process. Because of the time constant of the cavity, the measurements were limited to breakdown times greater than 1 μ sec. In the present experiment, breakdown is produced by pulsed microwaves in a narrow quartz tube placed in a microwave waveguide and the optical radiation from the plasma is used to study the temporal growth of the electron density. The radiation was viewed with a fast photomultiplier and sampling system which allowed breakdown times as short as 30 nsec to be studied. Experimental conditions were chosen such that losses by diffusion were negligible and, thus, the determination of the rate of growth of the electron density yielded the ionization frequency directly.

THEORY

During the diffusion-controlled microwave breakdown of a gas, there exist four distinct time regimes. The first regime involves that period of time at the beginning of the breakdown process during which free diffusion (D) of the electrons is the controlling loss mechanism. As the electron density grows, the free diffusion of electrons becomes affected by space charge and the loss by diffusion decreases. The diffusion coefficient in this second

regime is the effective diffusion coefficient (D_s).² The third regime occurs when the electron density grows to a sufficient value that space charge is fully developed and ambipolar diffusion (D_a) governs the loss mechanism. Finally, the electron density grows to such value that the microwave field in the plasma becomes sufficiently affected by the high-density plasma and the growth process stops. This experiment is concerned with the second and third regimes.

The rate of growth of electron density during the breakdown process is described by the equation,³

$$\partial n / \partial t = \nu_i n - \nabla^2 (Dn), \quad (1)$$

where n is the electron density, ν_i is the electron ionization frequency, D is the diffusion coefficient for the regime being studied, t is the time, and where all other loss mechanisms such as attachment and recombination have been neglected. Provided ν_i and D are constants, Eq. (1) is a standard characteristic value problem whose solution depends upon the geometry of the cavity in which the diffusion is taking place and upon the initial conditions. In a cylindrical cavity of length L and radius R , and for an axially symmetric but otherwise arbitrary initial distribution, the solution subject to the boundary conditions $n=0$ at $r=R$, $z=0$, $z=L$, can be written in the form

$$n(r, z, t) = \sum_{ml} A_{ml} \sin\left(\frac{m\pi z}{L}\right) J_0\left(\beta_{0l} \frac{r}{R}\right) \exp(\gamma_{ml} t). \quad (2)$$

In Eq. (2), β_{0l} is the l th root of $J_0(x)=0$ and

$$\gamma_{ml} = \nu_i - D/\Lambda_{ml}^2 = \nu_i - D[(m\pi/L)^2 + (\beta_{0l}/R)^2].$$

The A_{ml} are determined from the initial conditions.

Experimentally, we observe light integrated over the tube cross section at $z \cong L/2$. The quantity of interest

¹ M. P. Madan, E. I. Gordon, S. J. Buchsbaum, and S. C. Brown, Phys. Rev. **106**, 839 (1957).

² W. P. Allis and D. J. Rose, Phys. Rev. **93**, 84 (1954).

³ S. C. Brown, in *Handbuch der Physik*, edited by S. Flügge (Springer-Verlag, Berlin, 1956), Vol. 22, p. 531.

then is

$$N = 2\pi \int_0^R n\left(r, z = \frac{L}{2}, t\right) r dr,$$

and from Eq. (2) this is given by

$$\begin{aligned} N &= 2\pi \int_0^R \sum_{ml} \sin\left(\frac{m\pi}{2}\right) A_{ml} J_0\left(\beta_{0l} \frac{r}{R}\right) \exp(\gamma_{ml} t) r dr \\ &= 2\pi \sum_{ml} \sin\left(\frac{m\pi}{2}\right) A_{ml} \frac{R}{\beta_{0l}} J_1(\beta_{0l}) \exp(\gamma_{ml} t). \end{aligned} \quad (3)$$

It can be shown from Eq. (2) that there exists a time τ after which only the fundamental or lowest diffusion mode is important. This time depends on the initial density distribution. If it is assumed (for the pulsed experiments discussed here) that the electrons remaining from the preceding microwave pulse are diffusing only in the lowest mode and that the microwave field is uniform in all directions, then $\tau=0$ and Eq. (3) further reduces to

$$N = N_0 \exp(\nu_i - D/\Lambda^2)t, \quad (4)$$

where Λ is the characteristic diffusion length and is given by $1/\Lambda^2 = (\pi/L)^2 + (2.405/R)^2$. In the present experiment, these assumptions are justified by (1) allowing sufficient time between pulses to insure that any higher diffusion modes which happen to be present have decayed sufficiently that at the start of each pulse the density is in the lowest mode, and (2) recognizing that although there exists a sinusoidal variation of the microwave field in the axial direction, higher diffusion modes in the axial direction are less significant than in the radial direction because the experimental geometry was chosen with $L \gg R$. Furthermore, a correction for this variation of the field in the axial direction can be shown to be negligible at high E_0/p_0 .⁴

To avoid complications arising from the variations of D with time, conditions can be chosen such that the term D/Λ^2 is small compared with ν_i . Then a measurement of dn/dt yields ν_i directly. In the present work this was accomplished by (a) choosing the dimensions of the discharge tube appropriately, (b) working at sufficiently high electron densities that the diffusion coefficient was smaller than the free diffusion coefficient, and (c) working at large field strengths. As an example, consider breakdown at an $E_0/p_0 = 40$ V/cm-mm Hg. In our tube, $\Lambda \approx 0.20$ cm. For an electron density of the order of 10^8 cm⁻³ and a pressure of 10 mm Hg, $\nu_i/p_0 \approx 2.8 \times 10^6$ (sec mm Hg)⁻¹ and $D_-/p_0 \approx 1 \times 10^6$ cm² sec⁻¹ mm Hg.¹ Rose and Brown⁵ have shown that for the above conditions $D_s/D_- \approx 0.2$. Thus, for the example chosen, the ratio $\nu_i \Lambda^2/D \approx 50$. This ratio increases with increasing E_0/p_0 since ν_i increases with E_0/p_0 much faster than

D/Λ^2 . In the present experiment, then, the term D/Λ^2 can be neglected.

Determination of the rate of growth of electrons during the breakdown by observation of the optical radiation from the gas, requires that certain other conditions be met: (1) The time required for the electrons to obtain an energy distribution in equilibrium with the microwave field must be short compared with the observation time; (2) observation times must be greater than the mean lifetimes of the radiating states; (3) the electron energy distribution must be constant with time after the initial energy buildup. These conditions are now considered separately.

The time required for the electrons to reach a given energy distribution is given approximately by

$$\tau_E = \bar{u}/(u_c \nu_c), \quad (6)$$

where \bar{u} is the average energy of the final energy distribution, u_c is the average energy gained by an electron between collisions, and ν_c is the collision frequency. The energy \bar{u} depends on rates of excitation and of ionization, on the electric field strength, and on the pressure. This quantity has been determined by several investigators⁶ using distribution functions that give good agreement with breakdown data. The energy u_c is calculated from⁶

$$u_c = e^2 E^2 / [2m(\nu_c^2 + \omega^2)], \quad (7)$$

where E is the amplitude of microwave field and ω is its circular frequency. For the range of fields and pressures investigated here, the largest value of τ_E is 10×10^{-9} sec. The restriction then is that observations start at least 10 nsec after the application of the microwave field. It should be noted also that the propagation time of the microwaves across the discharge tube is less than 1 nsec.

When the optical radiation that is viewed originates in radiative transitions of excited hydrogen molecules an additional restriction must be placed on observation times. This results from the fact that excited states have finite radiative lifetimes. In order that the light emitted by the plasma at any instant of time be characteristic of the number of electrons at that time, the contribution to light from molecules excited previous to that time must be small. The number of photons per cm³ emitted at any time t_1 from a given excited state, is given by

$$\varphi \approx \int_0^{t_1} F n(t') \exp[-(t_1 - t')/\tau_R] dt', \quad (8)$$

where F is a function which depends on the excitation probability for the excited state, on the neutral particle density, on the average energy of the electron, and on geometry, but is independent of time; τ_R is the radiative lifetime of the state. For a breakdown process in which the time dependence of electron density is given by

$$n = n_0 e^{\nu t},$$

⁴ S. J. Buchsbaum, Quarterly Progress Report, Research Laboratory of Electronics, Massachusetts Institute of Technology, January 15, 1957 (unpublished), p. 10.

⁵ D. J. Rose and S. C. Brown, Phys. Rev. **98**, 310 (1955).

⁶ W. P. Allis and S. C. Brown, Phys. Rev. **87**, 419 (1952).

where n_0 is the initial electron density, Eq. (8) gives

$$\varphi = \frac{Fn_0}{(\gamma+1/\tau_R)} (e^{\gamma t_1} - e^{-t_1/\tau_R}) = Ce^{\gamma t_1} (1 - e^{-(\gamma+1/\tau_R)t_1}). \quad (9)$$

For φ to be proportional to the number density of electrons at time t_1 we must have

$$t_1 > \tau_R / (1 + \gamma\tau_R). \quad (10)$$

Lifetimes for states which decay by emission of photons in the optical portion of the spectrum are about 10^{-7} to 10^{-8} sec.⁷ Thus, for γ 's between 10^7 and 10^8 as found in this work, the inequality (10) is experimentally easily satisfied.

As a check of the proportionality between φ and N , we also observed the weak continuum radiation in a bandwidth of 10 \AA centered at 4650 \AA . Such radiation originates either in free-free transitions (bremsstrahlung) between electrons and neutral hydrogen molecules ($\tau_R \approx 0$), or in radiative transitions from the stable $^3\Sigma_g$ state to the unstable $^3\Sigma_u$ state ($\tau_R \approx 10^{-8}$ sec).⁸ For either radiation the inequality (10) is very well satisfied experimentally.

Finally, in order that the electron energy distribution be constant with time after the initial energy buildup, and independent of the number density of the electrons, it is important that new processes do not enter during the observation period. Thus, (1) the period of observation must be terminated before the electron density grows to the value where it affects the field strength within the plasma; (2) the fractional ionization of the gas must be sufficiently small to render the Maxwellization of the distribution by electron-electron collisions negligible; (3) the effect of dissociation on rate of growth

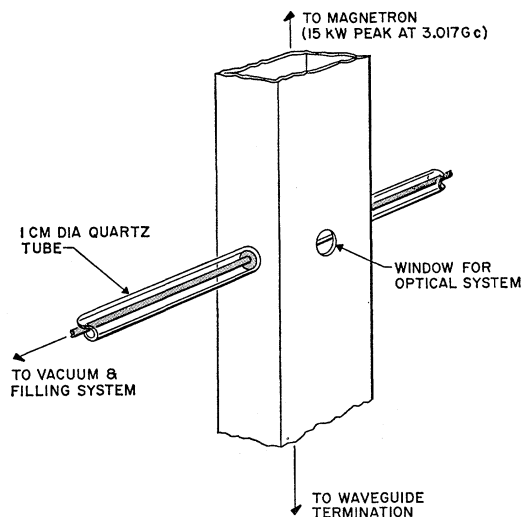

FIG. 1. Schematic of the experimental arrangement.

⁷ H. H. Landolt and R. Bornstein, *Tabellen* (Springer-Verlag, Berlin, 1950), 6th ed., Vol. I, Part I, p. 261.

⁸ H. M. James and A. G. Coolidge, *Phys. Rev.* **55**, 184 (1939).

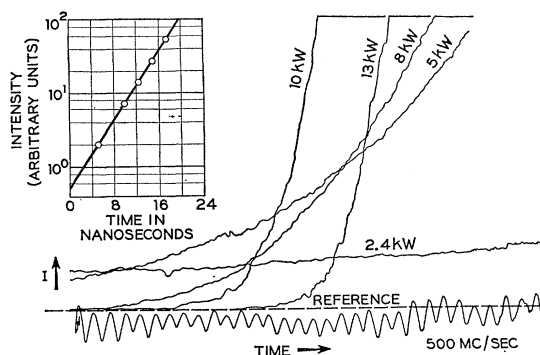

FIG. 2. Reproduction of an X-Y recorder tracing showing the light intensity I as a function of time for various microwave power levels; pressure = 8.6 mm Hg; microwave pulse duration = 1 μ sec; repetition rate = 1000 cps. In the insert, I is replotted on a semilog scale for a peak power of 5 kw.

and on light emission must be negligible. For the experimental frequency (3 kMc/sec), the observation period is limited to electron densities less than $5 \times 10^{10} \text{ cm}^{-3}$. At these densities, electron-electron collisions are negligible.

EXPERIMENT

A pulsed magnetron operating at 3017 Mc/sec fed microwave energy (maximum peak power—15 kW) into a waveguide system (1.5 in. \times 3 in.) operating in the TE_{01} mode. A small, known fraction of the power was coupled from the guide by a directional coupler to the thermistor and was used for power measurements. A quartz tube, 1 cm in diameter, connected to a vacuum system was placed through holes in the waveguide just beyond the power measuring arm. The tube was placed in the H plane of the guide with its axis perpendicular to the electric field. Copper disks were inserted in the tube to partially fill the openings in the wall of the guide and to act as boundaries for the plasma in the axial direction. This yielded a diffusion length for the lowest mode of $\Lambda = 0.21$ cm. The vacuum system could reach a pressure of 10^{-9} mm Hg before hydrogen was introduced. The hydrogen was obtained from commercial flasks of spectroscopically pure gas.

The light from the plasma was observed through a hole in the wide wall of the waveguide. The light passed through either a monochromator or a filter so that a predetermined spectral band could be observed with a photomultiplier that was connected to a sampling oscilloscope and X-Y recorder. The rise time of the optical system was approximately 3 nsec. Figure 1 shows part of the experimental arrangement.

Repetition rate of the microwave signal was maintained at 1000 cps with pulse widths of 1 and 2 μ sec. The rise time of the microwave pulse was 30 nsec. The high repetition rate was found desirable in order to maintain pulse to pulse time stability in the growth rate. At this high repetition rate, the electron density remaining from one pulse at the start of the next was still quite high—

varying with field strength and pressure from 10^3 to 10^6 cm⁻³. This did not interfere with the region of measurements reported here which was in the 10^8 to 5×10^{10} cm⁻³ range.

The time at which the electron density reached the value n_r corresponding to the resonance condition

$$\omega_p^2 = n_r e^2 / m \epsilon_0 = \omega^2, \quad (11)$$

was measured by determining the onset of reflection of the microwaves. If the light intensity corresponding to this density is denoted by I_r , the electron densities at all other times are obtained from the relation $n = (I/I_r)n_r$.

The data were reduced by reading the intensity values (in arbitrary units and scale) above the zero intensity reference from the X-Y plots at 2 nsec intervals for periods as long as 200 nsec (Fig. 2). The intensity values were plotted on a logarithmic scale as a function of time. A representative plot is shown in the insert in Fig. 2. The curve is very nearly a straight line indicating an exponential growth; the slope of the line is ν_i .

The values of ν_i so obtained for a range of E_e/p_0 from 36 to 200 V/cm-mm Hg are shown in Figs. 3 and 4. The electric field strength used was the effective field given by

$$E_e^2 = \frac{1}{2} E^2 \nu_c^2 / (\nu_c^2 + \omega^2), \quad (12)$$

where E is the amplitude of the applied field, ν_c is the electron collision frequency for momentum transfer, and ω is the circular frequency of the applied field. Since the photomultiplier viewed the center of the gas discharge tube at the center of the waveguide and since diffusion was negligible, peak field in the guide as determined from the power measurements was used in Eq.

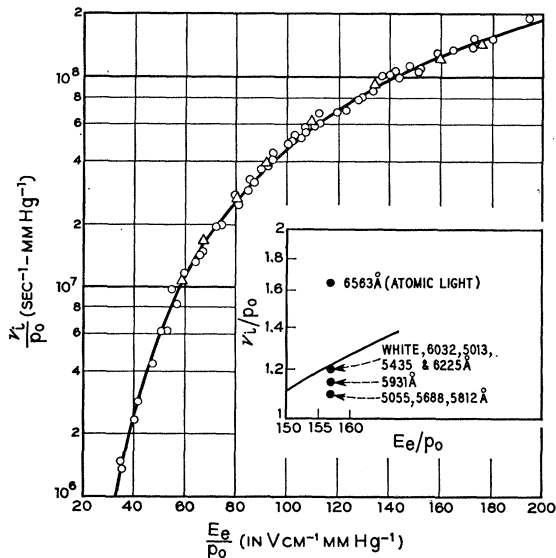

FIG. 3. Plot of ν_i/p vs E_e/p_0 for $\nu_c = 4.8 \times 10^9 p_0$; \circ , line radiation and white light; \triangle , continuum radiation; solid curve is calculated from measurements of Rose.

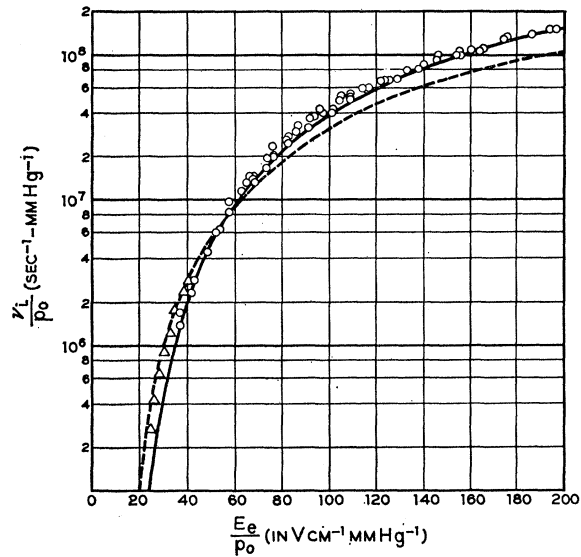

FIG. 4. Plot of ν_i/p_0 vs E_e/p_0 for $\nu_c = 5.9 \times 10^9 p_0$; \circ , present work; \triangle , Madan *et al.*; solid curve is calculated from measurements of Rose; dashed curve is from the Allis and Brown theory.

(12). Pressure was varied in the range of 1 to 10 mm Hg and read on a McLeod manometer. All pressures (p) were corrected to 0°C (p_0).

Power measurements were accurate to within 5%, pressure to 2% and time to 5%. Over-all accuracy of the data is $\pm 10\%$.

RESULTS AND CONCLUSIONS

Figure 3 shows the results of measurement of the electron ionization frequency, ν_i , divided by pressure, p_0 , plotted versus E_e/p_0 . A value of $4.8 \times 10^9 p_0$ has been used for the electron collision frequency in determining the effective electric field strength. The reason for this choice for ν_c will be discussed shortly.

The experimental points represented on this figure are the results of observing either white, or spectral, or continuum radiation from the plasma. The average of the experimental points is independent of the type of light being observed. At an E_e/p_0 of 157 V/cm-mm Hg, for example, ten points are shown in the insert in Fig. 3—one for white light (i.e., all radiation between 3000 and 7000 Å) and 9 for molecular spectra (i.e., bandwidths between 25 and 200 Å centered on the molecular lines). If atomic light is observed, it generally exhibits a faster growth rate than molecular light. This, of course, is due to the fact that atomic hydrogen density is also growing with time. No atomic light is included in the data being presented.

The solid line on the figure represents an ionization coefficient obtained from Rose's measured values of the Townsend coefficient α ,⁹ ν_i is obtained from α using the relationship $\nu_i/p_0 = \alpha \mu E_e/p_0$, where μ is the mobility.

⁹ D. J. Rose, Phys. Rev. 104, 273 (1956).

Again, $4.8 \times 10^9 p_0$ has been used for the electron collision frequency in determining the mobility μ .

Figure 4 is plotted for $\nu_c = 5.9 \times 10^9 p_0$, a value obtained by extending to all energies Brode's measured total collision frequency.¹⁰ It can be seen that the agreement between the microwave and the dc measurement is noticeably poorer in Fig. 4 (although it is still adequate) than in Fig. 3. Also, the use of $\nu_c = 4.8 \times 10^9 p_0$ tends to reduce appreciably the scatter in the experimental points.

The dashed curve in Fig. 4 shows the value of ν_c/p_0 obtained from the theory of Allis and Brown. A value of the collision frequency of $5.9 \times 10^9 p_0$ was used in this computation as specified in their original paper. Using a value of $4.8 \times 10^9 p_0$ for the collision frequency does not improve agreement with the experimental results. Also, the experimental points presented here do not seem to be joining with those reported by Madan,¹ which were in good agreement with the Allis and Brown theory.

We recall, however, that in Madan's experiments only a time *interval* was measured and that considerable corrections to the measured time had to be applied. The corrections were necessary partly because the electron density which determined the end of the time interval of necessity varied with gas pressure, but, most importantly, to account for the transition of the diffusion coefficient from D_- to D_s to D_a . We feel, therefore, that the agreement between Madan's measurements and the Allis and Brown theory may have been fortuitous.

Surely, in principle, dc and microwave measurements

¹⁰ R. B. Brode, Rev. Mod. Phys. 5, 257 (1933). See also Fig. 2 in reference 10.

ought to yield the same value for the ionization frequency provided the concept of effective electric field is valid. This question and the inadequacy of the Allis and Brown theory at high E_e/p_0 is further discussed in the following paper.¹¹

The agreement between the dc and microwave measurements should be especially good at $E_e/p_0 \lesssim 130$ V/cm-mm Hg. At higher E_e/p_0 there is some question, raised by Jones and Jones,¹² as to whether Rose interpreted his measurements properly in that he allegedly did not account for secondary emission from the cathode. Jones and Jones' measured (and corrected) values of α/p agree with those of Rose up to an E_e/p_0 of 130 V/cm-mm Hg, but then break rather sharply downward from Rose's curve and very nearly saturate with further increase of E_e/p_0 . The microwave measurements as well as the theoretical calculations presented in the following paper¹¹ do not exhibit such a break. We have, therefore, not corrected Rose's measurements nor used Jones and Jones' values. However, if the effect of secondaries is important and Rose's values of α/p need a downward revision at high E_e/p_0 , the agreement between microwave and dc measurements in Fig. 4 will cease to be "adequate" at high E_e/p_0 .

ACKNOWLEDGMENTS

We wish to thank Dr. S. C. Brown and Dr. A. V. Phelps for critical reading of the manuscript and Dr. A. V. Phelps for helpful discussions.

¹¹ G. A. Baraff and S. J. Buchsbaum, following paper [Phys. Rev. 130, 1007 (1963)].

¹² E. Jones and F. Llewellyn Jones, Proc. Phys. Soc. (London) 72, 366 (1958).