

Spin-Lattice Relaxation and Self-Diffusion in Liquid He<sup>3</sup>†\*

J. R. GAINES‡, K. LUSZCZYNSKI, AND R. E. NORBERG

*Department of Physics, Washington University, St. Louis, Missouri*

(Received 14 February 1963)

The spin-lattice relaxation time  $T_1$  and the coefficient of self-diffusion  $D$  were measured in liquid He<sup>3</sup> in the temperature range between 0.35 and 3°K at SVP. Pulsed nuclear magnetic resonance in a field of 6800 G was used. The measured  $T_1$ , characteristic of bulk relaxation, was found to pass through a minimum value of about 290 sec in the vicinity of 1°K. Surface relaxation effects were examined and possible explanations for the great diversity of the  $T_1$  values reported in the literature are given. Certain details of experimental procedure are described.

## INTRODUCTION

THE spin-lattice relaxation time  $T_1$  in liquid He<sup>3</sup> has been studied by many investigators.<sup>1-6</sup> The results obtained for  $T_1$  differ widely and in some cases it has been reported that the apparent  $T_1$  at any given temperature and pressure was not reproducible from one run to another.<sup>1,6</sup> Our measurements of  $T_1$  were started in the hope of obtaining reproducible values of  $T_1$  representing as nearly as possible the bulk relaxation in liquid He<sup>3</sup>. We also hoped to provide an explanation for the large discrepancies in  $T_1$  reported in the literature. In addition, we have made measurements of the self-diffusion coefficient in liquid He<sup>3</sup> at saturated vapor pressure in a field of about 6800 G. These measurements can be compared with results obtained in other laboratories.<sup>2,7</sup> Our initial measurements of  $T_1$  made in nylon, Delrin, Pyrex, and fused quartz cells, indicated that the nature of the surface in the sample container played an important role in the observed spin-lattice relaxation time of liquid He<sup>3</sup>. Quartz cells, which showed the smallest surface relaxation effects, were used in the  $T_1$  measurements reported below.

## EXPERIMENTAL ARRANGEMENT

Most of the measurements reported here were made at 22 Mc/sec in a field of 6790 G produced by a 12-in. electromagnet with a 3-in. gap. The pulsed nuclear magnetic resonance technique was employed.<sup>2,8,9</sup>

† This work was supported by a grant from the U. S. Army Research Office (Durham) and by an equipment loan contract with the Office of Naval Research.

\* Based on a thesis submitted by J. R. Gaines, in partial fulfillment of the requirements for the degree of Doctor of Philosophy, to the Graduate School of Washington University, St. Louis, Missouri.

‡ Present address: Ohio State University, Columbus, Ohio.

<sup>1</sup> W. M. Fairbank and G. K. Walters, *Symposium on Solid and Liquid Helium 3* (Ohio State University Press, Columbus, Ohio, 1957), p. 214.

<sup>2</sup> R. L. Garwin and H. A. Reich, *Phys. Rev.* **115**, 1478 (1959).

<sup>3</sup> R. H. Romer, *Phys. Rev.* **117**, 1183 (1960).

<sup>4</sup> G. Careri, I. Modena, and M. Santini, *Nuovo Cimento* **16**, 762 (1960).

<sup>5</sup> G. K. Walters, *Symposium on Liquid and Solid Helium 3* (Ohio State University Press, Columbus, Ohio, 1960), p. 37.

<sup>6</sup> F. J. Low and H. E. Rorschach, *Phys. Rev.* **120**, 1111 (1960).

<sup>7</sup> H. R. Hart and J. C. Wheatley, *Phys. Rev. Letters* **4**, 3 (1960).

<sup>8</sup> E. L. Hahn, *Phys. Rev.* **80**, 580 (1950).

<sup>9</sup> H. Y. Carr and E. M. Purcell, *Phys. Rev.* **94**, 630 (1954).

The equipment used in our experiments consisted mainly of units which are available commercially. The timing and pulse-generating circuits were built from modular pulse generators (160 series Tektronix). Pulses derived from these generators were amplified (General Radio Pulse Amplifier 1219-A) and then fed into a pulsed radio-frequency oscillator (Arenberg PG 650-C) which produced the necessary radio-frequency power. A half-wavelength cable (Amphenol 114) was used to couple the oscillator, i.e., the transmitter, to a single sample coil. The receiving amplifier was connected through appropriate matching networks to the tank circuit of the transmitter. This arrangement simplified the tuning procedure since only the tank circuit of the transmitter had to be adjusted for optimum performance. However, the signal-to-noise ratio of this arrangement is worse than in the case of individually tuned transmitter and receiver. Nevertheless, in most of our measurements the signal-to-noise ratio was quite adequate.

The nuclear signal, after amplification, was displayed directly on an oscilloscope (Tektronix 585) without demodulation. This was done to avoid any nonlinearities and corrections usually associated with demodulation of the radio-frequency signal. The signals were recorded photographically with a Polaroid camera. The amplitude of the nuclear signal was taken to be equal to the peak amplitude of the signal minus the thickness of the baseline including noise if any. The gain of the receiving chain was checked periodically during measurements, to correct for any long-term drift of the gain.

The experiments were performed in an all-metal Dewar system (constructed in our workshop) which was found to be very satisfactory and trouble free. Temperatures between 1.3 and 4.2°K were produced by pumping on a bath of liquid He<sup>4</sup>. A He<sup>3</sup> refrigerator<sup>10</sup> was used to produce temperatures below 1.3°K.

Temperatures were measured by means of carbon resistors (Allen Bradley  $\frac{1}{2}$  W) placed in the frequency determining network of a Wien bridge oscillator.<sup>11</sup> The resistors were calibrated against vapor pressure measurements over liquid He<sup>4</sup> and He<sup>3</sup>. In order to reduce the

<sup>10</sup> H. A. Reich and R. L. Garwin, *Rev. Sci. Instr.* **30**, 7 (1959).

<sup>11</sup> B. J. Sandlin and J. C. Thompson, *Rev. Sci. Instr.* **30**, 659 (1959).

power dissipated in these resistors the amplitude of oscillation was kept below 10 mV over the entire frequency range between 50 kc/sec and 1 Mc/sec. Two resistors with room temperature values of 9 and 50  $\Omega$  covered the range of temperatures between 0.3 and 4.2°K. The frequency of oscillations, measured by a digital frequency counter, was found to be an approximately linear function of the absolute temperature.

Sample cells were constructed out of nylon, Delrin, Pyrex, and quartz. Plastic cells were in the form of cylinders with 2.5-mm i.d. and the glass cells were approximately spherical. The effective length of the plastic cells could be accurately controlled by means of a plastic piston. By adjusting the position of the piston from the top of the experimental probe the effective volume of the sample could be easily changed. This feature was found to be very convenient in optimizing the volume of the sample. The plastic cells were sealed to metal tubing by means of a differential contraction seal.<sup>6,12</sup> For Pyrex bulbs, graded-glass-Kovar seals were used to connect the sample cells to the rest of the system. A schematic diagram of a quartz sample cell is shown in Fig. 1. This cell could be used for high-pressure experiments up to 1000 psi and possibly to much higher pressures. Though the quartz bulb itself is quite weak, the surrounding paraffin wax (filled with Pyrex powder to adjust the coefficient of expansion) enables it to withstand quite high pressures. The main function of the brass can, surrounding the sample cell, is to prevent He<sup>3</sup> from escaping into the adjacent vacuum jacket should the sample cell break.

Pressure could be applied to the sample by means of an oil-mercury Toepler pump activated by a hand-operated oil pump. The level of mercury in the pump was determined by measuring the resistance of a thin

platinum wire extended inside the pump. Pressures below 1 atm were measured with the aid of a mercury manometer connected to the sample tube. Pressures in excess of 1 atm were determined by means of a Bourdon gauge attached to the oil pump. Measurements of high pressure obtained in this way were found to be inaccurate because of the very large "dead volume" (mainly the volume of the compression chamber in the pump containing gaseous He<sup>3</sup>) associated with the gauge. An appreciable uncertainty in the pressure reading results from the fact that in such a system the time required for the sample and the pump to reach equilibrium is quite long. The system was later modified<sup>12</sup> and the pressure gauge was connected directly to the sample tube. The gauge was filled with glycerine and separated from the He<sup>3</sup> gas by a Teflon diaphragm. With this arrangement equilibrium readings were obtained in a matter of minutes.

#### EXPERIMENTAL PROCEDURE

In measuring the spin-lattice relaxation time we have employed a pulse sequence consisting in principle of  $90^\circ - \Theta - 90^\circ$ , where  $\Theta$  is the time interval between the  $90^\circ$  pulses. In practice, at time  $t=0$  several rf pulses are applied to the sample until there is no signal, i.e., the component of magnetization of the sample along the main field  $H_0$  is zero, or  $M_z(0)=0$ . After a waiting interval  $\Theta$  a pulse producing as nearly as possible a  $90^\circ$  rotation of  $M_z(\Theta)$  is applied and the resulting free-induction decay signal measured. The height of the free-induction decay  $h(\Theta)$  proportional to  $M_z(\Theta)$  is measured at a certain fixed distance, typically 1.5 msec, from the radio-frequency pulse. This is done to avoid any possible complications arising from the amplifier block-off effects.

If the recovery of  $M_z(\Theta)$  is governed by a single time constant  $T_1$  we have

$$h(\Theta) = h(\infty)[1 - \exp(-\Theta/T_1)]. \quad (1)$$

A plot of  $\ln[1 - h(\Theta)/h(\infty)]$  versus  $\Theta$  gives us  $T_1$ . When  $T_1$  is of the order of minutes, the determination of  $h(\infty)$  may become quite difficult. In principle one can determine  $T_1$  from two suitably spaced values of  $h(\Theta)$ , but in practice, in view of the complications described below, one has to determine the full recovery curve, that is to say  $h(\Theta)$  for several suitable values of  $\Theta$ .

The usual procedure employed in our experiments was to measure  $h(\Theta)$  for successively increasing values of  $\Theta$ , say,  $\Theta = 100, 200, \dots$  sec. After a whole series of points was obtained, the 200-sec picture was retaken, and if it did not agree with the initial picture within experimental error, the complete series was repeated until a satisfactory agreement was achieved. A typical measurement of one  $T_1$  point took several hours. Whenever possible the delayed function plot<sup>6,13</sup> of  $h(\Theta)$  versus  $h(\Theta + \Delta)$ , where  $\Delta$  is of the order of  $T_1$ , was used to determine  $h(\infty)$ .

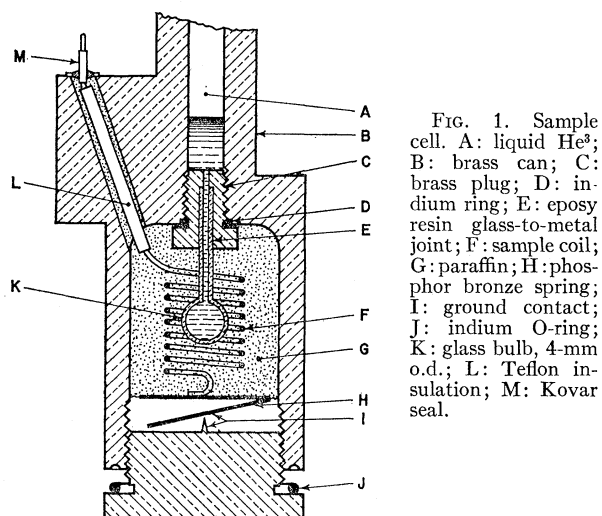

FIG. 1. Sample cell. A: liquid He<sup>3</sup>; B: brass can; C: brass plug; D: indium ring; E: epoxy resin glass-to-metal joint; F: sample coil; G: paraffin; H: phosphor bronze spring; I: ground contact; J: indium O-ring; K: glass bulb, 4-mm o.d.; L: Teflon insulation; M: Kovar seal.

<sup>12</sup> K. Luszczynski, R. E. Norberg, and J. Opfer, Phys. Rev. **128**, 186 (1962).

<sup>13</sup> P. C. Mangelsdorf, J. Appl. Phys. **30**, 442 (1959).

In many cases  $h(\Theta)$  was found to be governed by at least two time constants, so that

$$h(\Theta) = h_s(\infty)[1 - \exp(-\Theta/T_{1s})] + h_l(\infty)[1 - \exp(-\Theta/T_{1l})] \quad (2)$$

and

$$h(\infty) = h_s(\infty) + h_l(\infty),$$

where  $T_{1s}$  and  $T_{1l}$  are the short- and the long-relaxation times, respectively. The amplitudes of the two components are proportional to  $h_s(\infty)$  and  $h_l(\infty)$ . All the four constants in Eq. (2) can be deduced from a single plot of  $\ln[1 - h(\Theta)/h(\infty)]$  versus  $\Theta$ , if  $T_{1s} \ll T_{1l}$ . A plot of one set of experimental points taken from our data on He<sup>3</sup> liquid is shown in Fig. 2. This set of points was chosen merely to illustrate the procedure for determining the four constants in Eq. (2). The degree of complexity in  $h(\Theta)$  observed in the great majority of our

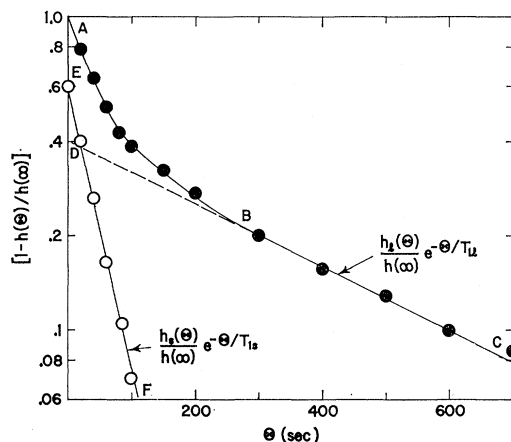

FIG. 2. A plot which shows a compound recovery of nuclear magnetization. This set of data, taken from measurements of the spin-relaxation time in liquid He<sup>3</sup>, at 2.5°K and at a pressure of about 1 atm, corresponds to the following constants in Eq. (2):  $T_{1s} = 47$  sec;  $T_{1l} = 430$  sec;  $h_s(\infty) : h_l(\infty) = 6:4$ .

measurements was generally very much smaller. Experimental points plotted in Fig. 2 are represented by the curve  $ABC$ . If  $T_{1s} \ll T_{1l}$ , then section  $BC$  is controlled entirely by  $T_{1l}$ . Hence, from the slope of  $BC$  we determine  $T_{1l}$  and from the intercept  $D$  of the extrapolation of  $BC$  on the ordinate axis we find the relative amplitude of this component, equal to  $h_l(\infty)/h(\infty)$ . Subtracting line  $CD$  from  $ABC$  gives us line  $EF$  which represents the short component. Hence, we can derive  $T_{1s}$  and  $h_s(\infty)/h(\infty)$ .

The spin-lattice relaxation time  $T_1$  was also determined by measuring the amplitude of the primary echo following a  $90^\circ$ - $180^\circ$  pulse sequence. The results obtained from the free-induction method and the echo method agreed within experimental error. However, the echo method is less satisfactory than the free-induction method because the amplitude of the echo is much more susceptible to any drifts of the apparatus from the reso-

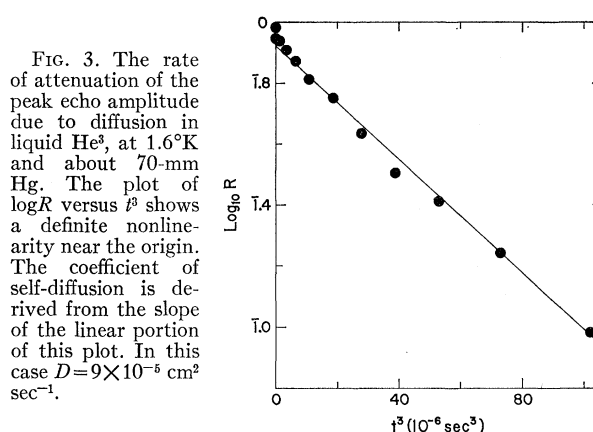

FIG. 3. The rate of attenuation of the peak echo amplitude due to diffusion in liquid He<sup>3</sup>, at 1.6°K and about 70-mm Hg. The plot of  $\log R$  versus  $t^3$  shows a definite nonlinearity near the origin. The coefficient of self-diffusion is derived from the slope of the linear portion of this plot. In this case  $D = 9 \times 10^{-6}$  cm<sup>2</sup> sec<sup>-1</sup>.

nance condition. For this reason the free-induction signal was used in our measurements of  $T_1$ .

Measurements of the self-diffusion coefficient were made with the aid of a pulse sequence consisting of three pulses, i.e.,  $90^\circ - \tau - 180^\circ - T - 180^\circ$ . This sequence gives rise to two echoes separated by a time interval  $t = 2(T - \tau)$ . If the attenuation of the peak echo amplitude is controlled mainly by diffusion, then the ratio of the peak amplitudes of the two echoes is<sup>2,9</sup>

$$R = \exp[-(\gamma G)^2 D t^3 / 12], \quad (3)$$

where  $\gamma$  is the gyromagnetic ratio,  $G$  is the linear field gradient along  $H_0$ , and  $D$  is the self-diffusion coefficient.

The linear field gradient  $G$  was produced by a pair of coils attached to the pole faces of the electromagnet. The value of  $G$  was derived from the signal shape obtained from samples with a very well defined geometry.<sup>2,9</sup>

In our measurements,  $R$  is determined for several values of  $t = 2(T - \tau)$ , where  $\tau$  is held constant and  $T$  varied. A plot of  $\ln R$  versus  $t^3$  gives a straight line which, when extrapolated back to  $t = 0$ , in most cases does not go through the origin. The effect is illustrated in Fig. 3, which shows that near the origin  $\ln R$  drops very rapidly compared with the main diffusion effect represented by the straight-line portion of the plot.

## RESULTS AND DISCUSSION

The experimental values of the spin-lattice relaxation time  $T_1$  obtained in a 3.5-mm-i.d. quartz sample cell at 22 Mc/sec are given in Fig. 4. Between 1 and 3°K,  $T_1$  increases with temperature. Measurements below 1°K indicate an apparent increase in  $T_1$  as the temperature is lowered. That is to say  $T_1$  goes through a minimum of about 290 sec between 0.5 and 1°K. The error flags in the figure represent the possible range of values of  $T_1$  that can be fitted to the experimental points obtained at any given temperature; the maximum possible error in  $T_1$  is estimated to be about  $\pm 10\%$ .

Figure 4 shows in addition to our experimental results a curve (solid line) drawn through the results for  $T_1$  obtained in a Pyrex bulb.<sup>3</sup> The two sets of data obtained

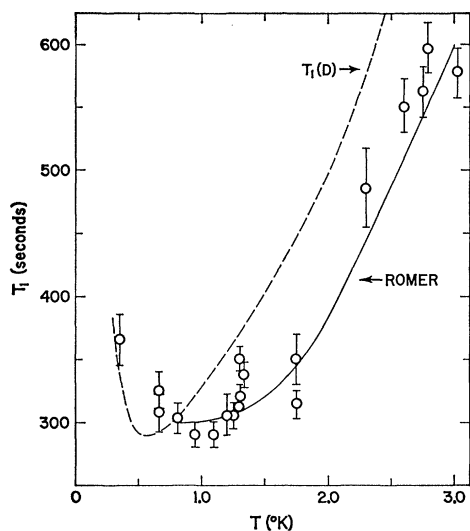

FIG. 4. The spin-lattice relaxation time  $T_1$  in liquid  $\text{He}^3$  at SVP:  $\circ$ —this research in a 3-mm quartz bulb; —, Romer (Ref. 3) in Pyrex bulbs, smoothed data; - - - -  $T_1(D)$ , derived from self-diffusion measurements (Ref. 7).

by different methods agree within the experimental error.

The reason for the observed minimum in  $T_1$  is not clearly understood. Many materials exhibit a  $T_1$  minimum in the temperature region where the correlation frequency  $\nu_c$  of the material is approximately equal to the Larmor frequency  $\nu_0$  employed in the experiment (in this case  $\nu_0 = 2.2 \times 10^7$  c/sec). The position of the minimum, thus, depends on  $\nu_0$ . The correlation frequency in  $\text{He}^3$  at  $0.5^\circ\text{K}$  is estimated to be  $\nu_c = 1/(2\pi\tau_c) = 2D/\langle r^2 \rangle \cong 10^{11}$  c/sec, where  $D$  is the self-diffusion coefficient and  $\langle r^2 \rangle$  is the mean-square interatomic distance. Since  $\nu_0/\nu_c \ll 1$ , we do not expect any dependence of  $T_1$  on  $\nu_0$ .<sup>14</sup> Indeed, our experiments show that at  $0.66^\circ\text{K}$  there is no dependence of  $T_1$  on the Larmor frequency in the range between 8 and 22 Mc/sec. It is quite clear that we cannot explain this minimum in  $T_1$  in the usual terms.

In ordinary liquids where  $\nu_0/\nu_c \ll 1$ , the spin-lattice relaxation time  $T_{1s}$  may be expressed in the following way<sup>14,15</sup>:

$$T_1 = (5a/2\pi\gamma^4\hbar^2N)D, \quad (4)$$

where  $a$  is the distance of closest approach,  $N$  is the number of magnetic moments per unit volume, and  $D$  is the self-diffusion coefficient. If we use the Stokes relationship,

$$3\pi\eta aD/kT = 1, \quad (5)$$

where  $\eta$  is the viscosity of the liquid, then Eq. (4) becomes

$$T_1 = (5k/6\pi^2\gamma^4\hbar^2N)(T/\eta). \quad (6)$$

<sup>14</sup> N. Bloembergen, E. M. Purcell, and R. V. Pound, *Phys. Rev.* **73**, 679 (1948); and R. Kubo and K. Tomita, *J. Phys. Soc. (Japan)* **9**, 888 (1954).

<sup>15</sup> H. C. Torrey, *Suppl. Nuovo Cimento* **9**, 95 (1958).

Experimental data on viscosity<sup>16</sup> and diffusion<sup>7</sup> in liquid  $\text{He}^3$  show that the Stokes relationship is not applicable to the liquid below about  $1.5^\circ\text{K}$ .<sup>17</sup> Correlating the experimental results for  $T_1$  and  $D$ , and also for  $T_1$  and  $\eta$ , we find that the temperature dependence of  $T_1$  is much more like that of  $D$  than that of  $(T/\eta)$ . In order to illustrate this point, the spin-lattice relaxation time derived from Eq. (4) and denoted by  $T_1(D)$  is plotted in Fig. 4 (dashed line). The constant in this equation is arbitrarily adjusted to make the minimum value of  $T_1(D)$  equal to the corresponding experimental value of about 290 sec. Above  $1.2^\circ\text{K}$ ,  $T_1(D)$  and the measured  $T_1$  have the same temperature dependence, within the experimental error. Below  $1^\circ\text{K}$ , the correlation between the measured  $T_1$  and  $T_1(D)$  is less satisfactory. However, measurements of diffusion and susceptibility<sup>7</sup> show that below  $1^\circ\text{K}$  the properties of the Fermi liquid become apparent in liquid  $\text{He}^3$  and, therefore, deviations from the classical liquid formulas should be expected. Qualitatively, it appears that  $T_1$  may be more sensitive to the Fermi-Dirac degeneracy than are diffusion or susceptibility, so that a departure of  $T_1$  from the classical behavior could occur at a higher temperature than the minimum of  $D$  or the deviation from Curie's law.

It is worth noting that the observed minimum in  $T_1$  might be associated with other phenomena. In particular, if the measured  $T_1$  were still partially controlled by the surface relaxation, a decrease in the effectiveness of the latter in this temperature region would also result in an apparent minimum in  $T_1$ . Our observations made in connection with the surface relaxation effects indicate that the values of  $T_1$  given in Fig. 4 represent the bulk spin-lattice relaxation free of wall relaxation; however, any relaxation by impurities suspended in liquid  $\text{He}^3$  cannot be entirely excluded.

The pressure dependence of  $T_1$  was investigated in quartz and nylon cells. In quartz cells, at  $3^\circ\text{K}$  for example,  $T_1$  decreases with increasing pressure. In nylon cells the pressure dependence of  $T_1$  is similar to that obtained in epoxy resin cells.<sup>2</sup> This dependence of  $T_1$  on pressure indicates that in quartz cells  $T_1$  is characteristic of bulk spin-lattice relaxation, while in nylon cells  $T_1$  is determined mainly by the surface relaxation. The temperature dependence of  $T_1$  in nylon cells (2.5 mm i.d. and 5 mm long) is very slight; typically  $T_1$  is of the order of 90 sec and it has a very broad maximum at about  $1.4^\circ\text{K}$  at 1 atm.

A certain amount of spurious relaxation was observed in all sample cells. It is difficult to make precise statements about this phenomenon because the observed effects are not completely reproducible, however, in most cases we found that (a) the recovery curve  $h(\Theta)$  consists of at least two components [cf. Eq. (2)], one having a short  $T_1 (= T_{1s})$  and a small amplitude and the

<sup>16</sup> K. N. Zinoveva, *Zh. Eksperim. i Teor. Fiz.* **34**, 609 (1958) [translation: *Soviet Phys.—JETP* **7**, 421 (1958)].

<sup>17</sup> E. F. Hammel, *Symposium on Liquid and Solid Helium 3* (Ohio State University Press, Columbus, Ohio, 1960), p. 6.

other having a long  $T_1 (= T_{1l})$  and representing some 90% of the signal amplitude; (b) the normalized signal shape depends on the waiting time  $\Theta$ , that is to say, the  $T_{1s}$  component is associated with a *short* free-induction decay and the  $T_{1l}$  component with a *long* decay (the length of the decay is determined by the distribution of  $H_0$  over the sample contributing to the signal); (c) the characteristics of the recovery curve  $h(\Theta)$  depend on the sample container.

In view of these complications a very careful analysis of the data has to be made to obtain meaningful results, since one can derive different values of  $T_1$  depending on the method of analysis.

In certain cases, by resolving  $h(\Theta)$  into two components (cf. Fig. 2) we found that  $T_{1s}$  remains approximately independent of temperature or perhaps rises slowly as the temperature is decreased. The long  $T_1$  component approaches the values shown in Fig. 4. If the average  $T_1$ , determined let us say from the half-height of  $h(\Theta)$  were taken, the result would have been quite different. It was found that the average  $T_1$  exhibits a maximum in the vicinity of 1.4°K at SVP. This behavior arises partly from the fact that the relative amplitudes of the components change with temperature, i.e., the amplitude of the short  $T_1$  component decreases as the temperature is lowered. In general, the ratio of these amplitudes does not remain constant from one run to another at any given temperature and pressure. This could account for the apparent irreproducibility of  $T_1$  values.

Our observations can be explained in terms of surface relaxation, occurring at liquid-wall and liquid-vapor interfaces. The relaxation at the liquid-wall interface has a very pronounced effect on the measured  $T_1$ . For instance, in going from a quartz bulb to a nylon container, we find that the measured  $T_1$  is reduced from some 600 to 90 sec at 3°K and SVP, with all other conditions being equal. The effective  $T_1$  in the He<sup>3</sup> vapor in contact with a rapidly relaxing surface is quite short,<sup>12</sup> of the order of a few seconds. Thus, the presence of vapor in the sample cell, or even close to it, results in a compound signal with long and short  $T_1$  components whose amplitudes depend on temperature as well as on the relative amounts of liquid and vapor in the cell.

Since the spurious relaxation phenomena were only of incidental interest to us, our observations of these effects are incomplete. Nevertheless, we can indicate possible explanations for most of the spurious relaxation effects reported in the literature.

Measurements of Garwin and Reich<sup>2</sup> in liquid He<sup>3</sup> under pressure in epoxy resin cells are very similar to those made by us in nylon cells. The measured  $T_1$  represents surface relaxation superimposed on a comparatively very much weaker bulk relaxation. The relaxation time of the bulk liquid is proportional to the self-diffusion  $D$ , whereas the surface relaxation time is inversely proportional to  $D$ . The superposition of the two effects gives rise to broad maxima in the measured

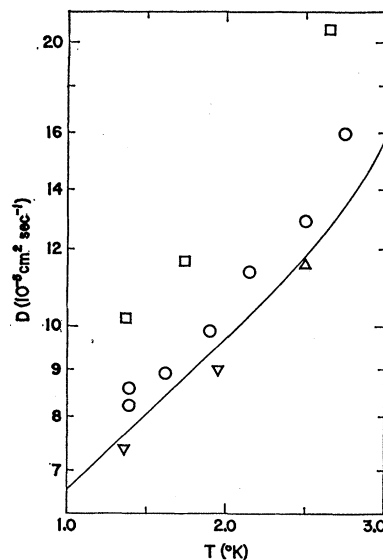

FIG. 5. The coefficient of self-diffusion  $D$  in liquid He<sup>3</sup> at SVP. Several different sample containers were used:  $\nabla$ —2.5-mm-i.d., 5-mm-long Delrin cylinder;  $\triangle$ —3-mm-i.d. quartz bulb;  $\circ$ —8-mm-i.d. Pyrex bulb;  $\square$ —10-mm-i.d. Pyrex bulb; the solid line represents the results of Hart and Wheatley (Ref. 7) obtained in a 7.6-mm-i.d., 8.4-mm-long epoxy resin cylinder.

$T_1$  versus  $T$ , which shift to higher temperatures as the pressure is increased. Some of the very pronounced peaks in the measured  $T_1$  reported by Careri, Modena, and Santini<sup>4</sup> were also observed in our experiments when vapor was present in our samples. Invariably, under those conditions the recovery curve  $h(\Theta)$  is compound. The relative amplitudes of the two  $T_1$  components change with temperature. The major effect arises from the change in the amount of liquid in the sample cell. If the recovery curve is resolved into two components, then the values of the long  $T_1$  approach those given in Fig. 4. Experiments with a metal probe suspended in the vapor above liquid He<sup>3</sup> reported by Walters<sup>5</sup> can be also explained in similar terms. The results of Low and Rorschach<sup>6</sup>, specifically the field dependence of  $T_1$ , are not understood. Our measurements of  $T_1$  in nylon containers show no field dependence. Finally, it is reasonable to assume that Romer<sup>3</sup> was able to measure the bulk relaxation times because of a favorable sample geometry and design. His system consisted entirely of Pyrex glass which is much less effective in relaxing He<sup>3</sup> atoms than most other materials. Moreover, Romer reported that his sample cell was full of liquid at all times during the measurements.

The results for the self-diffusion coefficient  $D$  in liquid He<sup>3</sup> measured in the field of about 6800 G and at SVP are shown in Fig. 5. These measurements were made in glass and plastic cells with different geometry and dimensions.

Measurements of  $D$  made in small diameter ( $\sim 3$  mm) cells gave values which are in good agreement with those obtained by Hart and Wheatley,<sup>7</sup> but the meas-

ured values of the self-diffusion coefficient in larger ( $\sim 8$  mm Pyrex) sample cells fall systematically higher. For instance, the apparent self-diffusion coefficient  $D$  in a 10-mm Pyrex cell is some 40% higher than that obtained in a 3-mm quartz bulb. A more accurate study of this phenomenon would be required to determine definitely whether we are dealing, in fact, with a "size effect," that is to say, a limitation of the atomic self-diffusion due to the finite size of the container, or whether this behavior is entirely due to some systematic errors of measurement.

In our apparatus we could not use sample bulbs much larger than 10-mm diam mainly because the natural homogeneity of the polarizing field  $H_0$  was relatively poor and secondly because the external gradient generated by the gradient coils would not remain reasonably linear over a region bigger than 10 mm. Moreover, in large bulbs, temperature gradients and the resulting convection are more easily set up. A Carr-Purcell pulse sequence<sup>9</sup> was used to verify that no appreciable convection was present during our measurements. On the basis of these tests we exclude convection as a possible cause of the observed size effect.

Error in  $D$  arising from the increase in the non-linearity of the external field gradient  $G$  as the sample size is increased, is estimated to be less than 1%. Therefore, this nonlinearity cannot account for the observed 40% difference in  $D$ . Other possible instrumental effects show a similar disparity between the estimated and the observed size effects.

The self-diffusion coefficient as measured by the spin-echo technique can be decreased by the presence of artificial barriers perpendicular to the direction of the main magnetic field gradient. Qualitatively, then, in very small cells the apparent self-diffusion should be smaller than in the bulk liquid. To evaluate the maximum possible effect of the wall of the container on self-diffusion let us divide the sample into two regions: One region consisting of atoms which within the measured diffusion time (defined arbitrarily as the time in which  $R$  decays to  $R/e$ , and typically of the order of 40 msec) suffer some degree of retardation in their diffusion rate due to the presence of the wall; the other region containing atoms, remaining in the bulk of the liquid, which do not come in contact with the wall. In the case of our 2.5-mm-i.d., 5-mm-long cylindrical plastic cell, we find that the maximum possible fraction of the volume of the liquid that can be retarded by the wall is less than 2%. This result is obtained on the assumption<sup>18</sup> that the rms distance traveled by an atom along an axis in time  $t$  is about  $(2Dt)^{1/2}$ . The estimated retarding effect of the wall is very much smaller than the observed effect. In view of this, the observed "size effect" becomes rather difficult to understand. Further measurements of  $D$  in

sample containers with widely different dimensions would provide more conclusive results.

We have also observed that the apparent self-diffusion is very much higher when the sample bulb contains some vapor in addition to the liquid. This can be accounted for by recognizing the fact that the observed nuclear signal in such a case is composed of two components associated with the vapor and the liquid. The two signals have very different spin relaxation times and coefficients of diffusion, so that the behavior of the nuclear signal is quite complex. In fact, under these circumstances the measured self-diffusion coefficient depends on the waiting interval  $\Theta$  between pulse sequences, that is to say, the apparent  $D$  decreases as  $\Theta$  is increased. These difficulties can be avoided by employing excess vapor pressures so that the sample bulb remains filled with liquid. Even under those conditions there still is a "fast-diffusion" component in the diffusion plot, as illustrated in Fig. 3. The plot of  $\ln R$  versus  $t^2$  for the small  $t$  ( $\lesssim 15$  msec) is not linear. In the derivation of the self-diffusion coefficient in the liquid, this nonlinear region is disregarded and a best straight line drawn through the remaining points. Thus, the results for  $D$  plotted in Fig. 5 correspond to the linear section of  $\ln R$  versus  $t^2$ . The presence of the nonlinearity in  $\ln R$  is *not* due to an imperfect pulse sequence,<sup>2</sup> because experimentally  $R$  approaches unity as  $t$  is reduced to zero. There appears to be no correlation between this effect and the size of the sample.

## CONCLUSIONS

Our measurements of the spin-lattice relaxation time  $T_1$  in liquid  $\text{He}^3$  show that  $T_1$  goes through a minimum of some 290 sec in the vicinity of 1°K. Insofar as the measured  $T_1$  represents the spin-lattice relaxation in the bulk liquid  $\text{He}^3$ , it appears that  $T_1$  reflects the non-classical nature of the liquid at low temperatures. Most of the variation in the  $T_1$  data reported in the literature can be interpreted in terms of surface relaxation effects at the liquid-vapor or the liquid-wall interface.

Measurements of the coefficient of self-diffusion  $D$  at SVP, in a field of 6800 G, made in small sample cells, agree reasonably well with those reported by Hart and Wheatley,<sup>7</sup> which were made in a comparatively low magnetic field. The measured values of  $D$  in larger sample cells fall systematically higher, outside our estimate of the maximum possible experimental error. Further and more extensive measurements of  $D$  would be required to establish conclusively whether we are dealing with a real "size-effect" of the sample cell on  $D$  or whether the observed phenomenon results from a combination of certain instrumental effects.

## ACKNOWLEDGMENTS

We wish to thank L. Vossel for his expert technical assistance in the construction and operation of the cryogenic apparatus.

<sup>18</sup> W. Jost, *Diffusion in Solids, Liquids and Gases* (Academic Press Inc., New York, 1960), p. 25.