

Emission of Prompt Gamma Rays in the Thermal-Neutron Fission of U^{235}

S. S. KAPOOR AND R. RAMANNA

Atomic Energy Establishment, Trombay, Bombay, India

(Received 16 July 1963; revised manuscript received 28 October 1963)

The angular distributions of prompt-fission gamma rays with respect to the direction of selected fission fragments in the thermal-neutron fission of U^{235} have been studied for two different gamma-energy groups, using a gridded ionization-chamber scintillation-detector assembly and time-of-flight method to eliminate fission-neutron background. From the measured angular distributions with respect to the direction of the selected light fragments, the values of the laboratory anisotropy $\{N(0^\circ) - N(90^\circ)\}/N(0^\circ)$ for gamma rays of energies greater than 180 and 510 keV are found to be 14.9% and 12.2%, respectively. For the ratio of the intensities of the gamma rays of energies greater than 180 keV along the direction of the selected light and heavy fragments, a value equal to (0.985 ± 0.024) has been obtained, showing that the heavy fragments emit somewhat more gamma rays than the light fragments. These measurements definitely show the existence of a significant anisotropy of emission of the gamma rays in the emitting-fragment system, suggesting the presence of significant angular momenta of the fragments correlated with the fission axis which also lead to an enhanced emission of the gamma rays.

I. INTRODUCTION

SEVERAL new observations on the emission of prompt gamma rays in fission are not in agreement with the predictions of the evaporation theory where it is assumed that the gamma rays are emitted from the excited fission fragments after they have emitted all the neutrons possible. Recent measurements by Smith *et al.*,¹ Maienschein *et al.*,² and by Bowman and Thompson³ show that the average value of the energy emitted as prompt gamma rays per fission is almost twice the value calculated^{4,5} in the evaporation theory showing that gamma emission competes effectively with the neutron emission. It is also found that the average energy of prompt gamma rays in fission (~ 1 MeV) is much smaller than the average energy (~ 2 MeV) of the gamma rays emitted in the thermal-neutron capture,⁶ which cannot be explained on the basis of a slightly higher, typical first photon emitting state of the compound nucleus formed by neutron capture, as pointed out by Halpern.⁷ If, however, the fragments have large angular momenta correlated with their directions of motion, a spin-dependent formulation of the statistical theory is required to analyze the de-excitation process of the fission fragments. The angular correlation of prompt gamma rays and fission fragments provides

information on the existence of the angular momenta of the fission fragments, but its determination is somewhat difficult, due to the presence of a highly correlated background of the fission neutrons especially of the higher energies which are very strongly anisotropic.⁸ This may be the reason why some earlier measurements^{9,10} on the fragment-gamma angular correlation have given inconsistent results. The present paper describes an experimental determination of the angular correlation of prompt gamma rays of two energy groups and selected fission fragments eliminating the prompt neutrons by the time-of-flight method.

II. METHOD AND EXPERIMENTAL ARRANGEMENT

The experimental procedure is similar to the one used for determining the angular correlation of the fission fragments and the prompt neutrons, the details of which are described in a previous paper,¹¹ and only a brief description is given here. Figure 1 shows the schematic diagram of the experimental arrangement. A gridded ionization chamber with its cathode coated with a layer of U^{235} , having thickness $100 \mu\text{g}/\text{cm}^2$, was filled with pure xenon gas and the scintillations in the gas at the instant of fission were observed by the photomultiplier RCA 6810A giving the zero-time pulse. The assembly was placed in front of the thermal column of the Apsara reactor. A plastic scintillator of 4 cm thickness, well-shielded to reduce the background, was coupled with the photomultiplier RCA 7046 and kept along the electric-field direction of the ionization chamber, with the face of the scintillator at a distance of 103 cm from the uranium foil, to detect the prompt radiations. The time difference between the zero-time pulse and the

¹ A. B. Smith, P. R. Fields, A. M. Friedman, S. Cox, and R. K. Sjoblom, in *Proceedings of the International Conference on Peaceful Uses of Atomic Energy, Geneva, 1957* (CERN, Geneva, 1958), Vol. 15, p. 392.

² F. C. Maienschein, R. W. Peelle, W. Zobel, and T. A. Love, *Proceedings of the International Conference on Peaceful Uses of Atomic Energy, Geneva, 1957* (CERN, Geneva, 1958), Vol. 15, p. 212.

³ H. R. Bowman and S. G. Thompson, *Proceedings of the International Conference on Peaceful Uses of Atomic Energy, Geneva, 1957* (CERN, Geneva, 1958), Vol. 15, p. 212.

⁴ J. Terrell, *Phys. Rev.* **113**, 527 (1959).

⁵ R. B. Leachman, *Phys. Rev.* **101**, 1005 (1956); R. B. Leachman and C. S. Kazek, Jr., *ibid.* **105**, 1511 (1957).

⁶ L. V. Groshev, A. M. Demidov, V. N. Lutsenko, and V. I. Pelekhov, in *Proceedings of the International Conference on Peaceful Uses of Atomic Energy, Geneva, 1957* (CERN, Geneva, 1958), Vol. 15, p. 138.

⁷ I. Halpern, *Ann. Rev. Nucl. Sci.* **9**, 298 (1959).

⁸ R. Ramanna, R. Chaudhry, S. S. Kapoor, K. Mikke, S. R. S. Murthy, and P. N. Rama Rao, *Nucl. Phys.* **25**, 136 (1961).

⁹ W. J. Whitehouse, *Progr. Nucl. Phys.* **2**, 120 (1952).

¹⁰ R. B. Leachman, in *Proceedings of the International Conference on Peaceful Uses of Atomic Energy, Geneva, 1957* (CERN, Geneva, 1958), Vol. 15, p. 331; M. Hoffman, *Bull. Am. Phys. Soc.* **3**, 6 (1958).

¹¹ S. S. Kapoor, R. Ramanna, and P. N. Rama Rao, *Phys. Rev.* **131**, 283 (1963).

plastic scintillator pulse was converted into pulse height by a time to pulse-height converter.¹² The side-channel discriminator outputs of the two photomultipliers were fed to a slow coincidence unit which gated the output of the time to pulse-height converter. The side-channel discriminator of the plastic scintillation detector was calibrated, using standard gamma-ray sources to select gamma rays of energies greater than a certain fixed energy. The time-of-flight method for selecting the gamma rays has the advantage over the fast coincidence method in that the gamma rays can be selected with high efficiency, eliminating the fission neutrons completely.

For a fragment of kinetic energy ϵ_f , the pulse at the grid of the ionization chamber is given by $Vg = \text{const} \epsilon_f \times \{1 - (R^* \cos\theta/d_{gc})\}$, where R^* is a quantity depending only on the range of the track, d_{gc} is the grid-cathode distance, and θ is the angle of the track with the electric-field direction. The grid pulse height for fragments of selected kinetic energy is, therefore, a measure of $\cos\theta$ and its distribution gives the angular distribution of the fission fragments. For thermal fission, the angular distribution is isotropic and was used to calibrate the grid pulse heights in terms of $\cos\theta$. The block diagram of the electronic arrangement to determine the coincidence rate between the selected gamma rays and the selected fragments moving at different angles is shown in Fig. 2. The chance coincidences due to background pulses in the plastic scintillation detector were accurately determined by keeping the detector at an arbitrary place outside the line of detection in the field of an external background source. The shielding arrangement ensured that no coincident-fission gamma

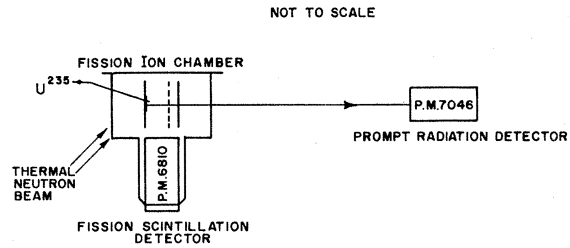

Fig. 1. Schematic diagram of the experimental arrangement.

rays reach the detector. The background was calculated by normalizing the chance coincidences to the same input-counting rates as present during the measurement. The angular distribution of the chance coincidences was found to be isotropic within a statistical accuracy of one percent, showing that the coincidence efficiencies of the different coincidence units are the same and no systematic error is involved.

III. EXPERIMENTAL RESULTS AND ANALYSIS

The full width at half-maximum of the gamma peak in the observed time-of-flight distribution was about 6 nsec and the gamma rays were selected only in the time-of-flight region extending up to a maximum of 12 nsec. This eliminated practically all the fission neutrons as the energy needed for a neutron to have this time of flight is (40 ± 20) MeV. The light and heavy fragments were selected at the peaks of the kinetic-energy distribution with the full width $2\Delta\epsilon_f \approx 10$ MeV in each case. The angular correlations of the gamma rays and the selected light fragments were obtained for

Fig. 2. Block diagram of the electronic arrangement. This employs a slow-fast coincidence arrangement with negative time elimination. The coincidence pulse selecting the gamma peak is fed to one of the inputs of each of the four coincidence units. The pulses corresponding to the different angles of the direction of motion of the selected fragments are fed to the other inputs of the coincidence units. The coincidences are recorded in the "scaler" and the corresponding number of fission events in "monitor."

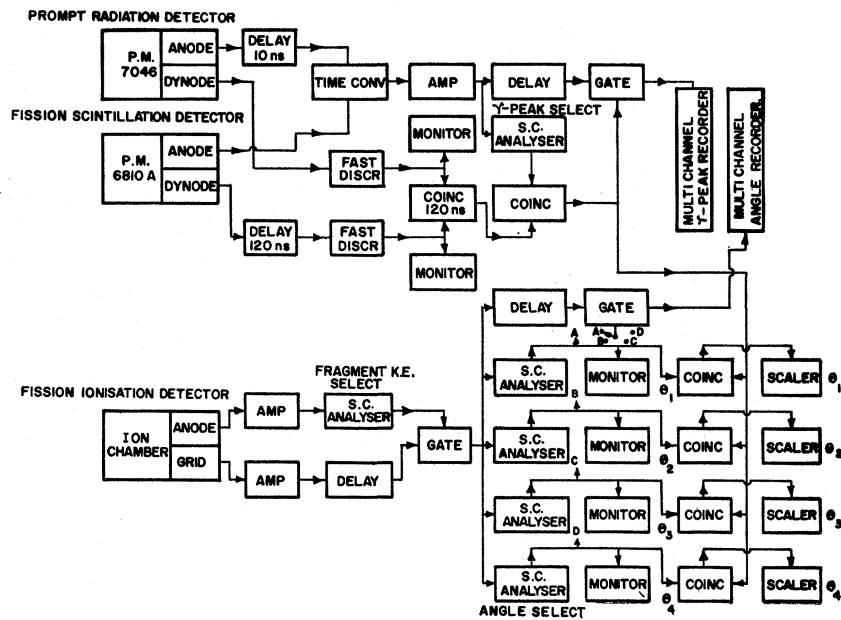

¹² J. B. Garg, Nucl. Instr. Methods 6, 72 (1960).

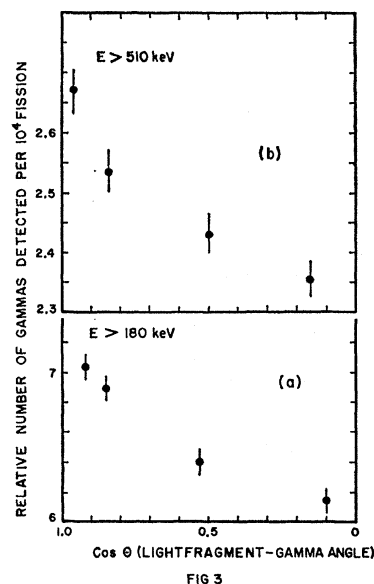

FIG. 3. Measured angular distributions of the gamma rays with the direction of motion of the light fragments.

gamma rays of energies greater than 180 and 510 keV and are shown in Fig. 3(a) and (b). Calibration of the side-channel discriminator for these two energies was done using a U^{235} and a Na^{22} source, respectively. The relative intensity of the gamma rays of energy greater than 180 keV along the direction of the selected light and heavy fragments was measured, and the following result was obtained:

$$[N_L(\theta)/N_H(\theta)]_{(\theta)=12^\circ} = (0.985 \pm 0.024),$$

where $N_L(\theta)$ and $N_H(\theta)$ are the number of the gamma rays detected at an angle θ in coincidence with the light and heavy fragments, respectively, which are moving into the gas. This shows that the laboratory anisotropies with respect to the direction of the light and heavy fragments are nearly equal.

If a gamma ray is emitted from a moving fragment having velocity v at an angle ψ in the fragment system and observed to move at an angle θ in the laboratory system, the Lorentz transformation of coordinates gives

$$\tan\psi = (1 - \beta^2)^{1/2} \{ \sin\theta / (\cos\theta - \beta) \}, \quad (1)$$

where $\beta = v/c$. This leads to

$$N(\theta) = n(\psi) \{ (1 - \beta^2) / (1 - \beta \cos\theta)^2 \}, \quad (2)$$

where $n(\psi)$ and $N(\theta)$ are the number of the gamma rays per fission per unit solid angle in the fragment system and in the laboratory system, respectively.

For $\beta \ll 1$ and, therefore, $\psi \approx \theta$ one gets

$$N(\theta) = \{ n(\theta) / (1 - \beta \cos\theta)^2 \}. \quad (3)$$

The number $N_L(\theta)$ and $N_H(\theta)$ of the gamma rays in coincidence with the light and heavy fragments,

respectively, are given by

$$N_L(\theta) = \text{const} \left[\{ R_\gamma n_L(\theta) / (1 - \beta_L \cos\theta)^2 \} + \{ n_H(\theta) / (1 + \beta_H \cos\theta)^2 \} \right], \quad (4)$$

$$N_H(\theta) = \text{const} \left[\{ n_H(\theta) / (1 - \beta_H \cos\theta)^2 \} + \{ R_\gamma n_L(\theta) / (1 + \beta_L \cos\theta)^2 \} \right], \quad (5)$$

where L and H refer to the light and heavy fragments respectively and R_γ is the ratio of the emission probabilities of the gamma rays from the light and heavy fragments.

As the fragments are completely stopped in the gas and in the backing in a time of about 10^{-9} and 10^{-12} sec, respectively, and the time of emission of the gamma rays is expected¹³ to be less than 10^{-10} sec, it seems certain that the fragments moving into the gas have their full velocities at the time of gamma emission. If some gamma rays are emitted at about the same time as the neutrons, the fragments moving into the backing will also have their full velocities at the time of emission of these gamma rays. However, the anisotropy of gamma emission arising entirely due to the motion of the fragments for any possible values of R_γ and the velocities of the fragments is found to be much smaller than the observed anisotropy establishing the presence of the anisotropic emission of the gamma rays in the fragment system.

The laboratory angular distributions were transformed to the fragment system for the different cases of the velocities of the fragments at the time of gamma emission and under the assumptions of $R_\gamma = 1$ and $n_L(\theta) \approx n_H(\theta)$. The plots of $n(\theta)$ against $\sin^2\theta$ for the different cases are shown in Fig. 4, where the continuous lines are the least-square fits to the experimental points in the various cases. The fit suggests that the angular distribution is of the type $n(\psi) \approx (1 - \alpha \sin^2\psi)$, which is expected if the anisotropy arises due to the polarized high angular momenta of the fragments. The values of α obtained for the various cases are given in Fig. 4 showing that the anisotropy of gamma emission is about 10%–15%. The statistical error in the values of α are less than 0.5% and 1.5% for the cases of $E > 180$ and $E > 510$ keV, respectively. Results reported recently by Desi *et al.*¹⁴ and Blinov *et al.*¹⁵ lead to similar values of the anisotropy after allowing for the proper transformation corrections.

It can be seen from Fig. 4 that the measured anisotropy (α_1) is lesser for the high-energy group of the gamma rays and α_2 for $E > 510$ keV is nearly the same as α_3 for $E > 180$ keV. A possible explanation to this is that the high-energy gamma rays are emitted earlier than the low-energy gamma rays and the fragments

¹³ S. Desi, A. Lajtai, and L. Nagy, Acta Phys. Acad. Sci. Hung. 15, 185 (1962).

¹⁴ S. Desi, G. Graff, A. Lajtai, and L. Nagy, Phys. Letters 3, 343 (1963).

¹⁵ M. V. Blinov, N. M. Kazarinov, A. N. Protopopov, and V. M. Shiryayev, Zh. Eksperim. i Teor. Fiz. 43, 1644 (1962) [translation: Soviet Phys.—JETP 16, 1159 (1963)].

FIG. 4. Plots of $n(\theta)$ against $\sin^2\theta$. The straight lines are least-square fits to the experimental data, giving anisotropies α_1 , α_2 , and α_3 after transformation to the fragment system under the assumptions (i) $\beta_L = \beta_H = 0$, (ii) $\beta_L = 0.0473$, $\beta_H = 0.0321$, and (iii) $\beta_L = 0.0473$, $\beta_H = 0$, respectively. The broken lines show the anisotropy of the gamma rays arising purely due to emission from the moving fragments in cases (ii) and (iii).

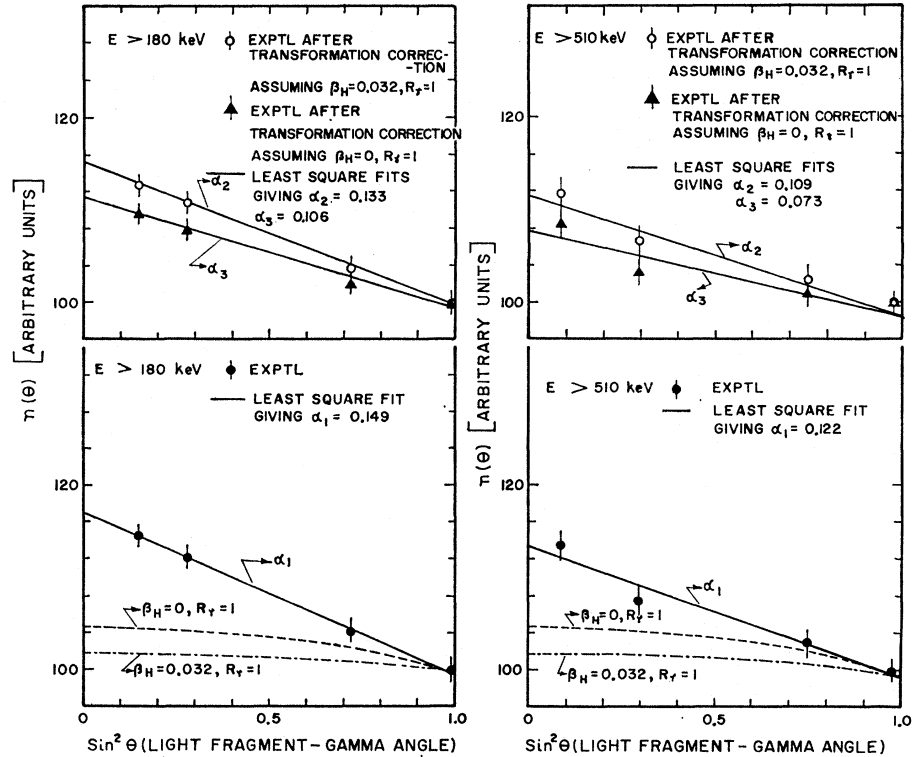

going into the backing have their full velocities only at the time of emission of the high-energy gamma rays. However, it is also possible that the difference in the observed anisotropies for the two groups is due to the difference in the anisotropies in the fragment system itself.

The measured ratio of the intensities of the gamma rays nearly along the direction of motion of the light and the heavy fragments contains the information on the value of R_γ . From Eqs. (4) and (5), one obtains

$$\frac{N_L(\theta)}{N_H(\theta)} = \left[\frac{R'(1 - \alpha_L \sin^2\theta)}{(1 - \beta_L \cos\theta)^2} + \frac{(1 - \alpha_H \sin^2\theta)}{(1 + \beta_H \cos\theta)^2} \right]^{1/2} \quad (6)$$

where

$$R' \simeq R_\gamma \left[1 + \frac{2}{3}(\alpha_L - \alpha_H) \right]. \quad (7)$$

As the difference $\alpha_L - \alpha_H$ can at the most be equal to the average anisotropy α which is about 0.10, one obtains $0.94R' < R_\gamma < 1.07R'$, and thereby R' is very nearly a measure of R_γ . From the measured value of $[N_L(\theta)/N_H(\theta)]_{\langle\theta\rangle=12^\circ}$ and Eq. (6), for the cases when the fragment moving into the backing has zero velocity and full velocity, one obtains $R' = 0.43_{-0.25}^{+0.40}$ and $R' = 0.54_{-0.17}^{+0.21}$, respectively. The calculated values of R' are very sensitive to the measured ratio, as the statistical uncertainty of about 2.5% in the measured ratio results in errors of about 40% to 90% in the

calculated values of R' . In view of this, though an exact value of R_γ cannot be inferred from the present measurements, the calculated values suggest that R_γ is less than one.

IV. DISCUSSION

The observed anisotropy of emission of the gamma rays of about 10%–15% and the form of the angular distributions show that the fragments are formed with a significant average angular momentum correlated with the fission axis, the large angular momentum arising in the possible case of the nonaxial splitting of the neck, as suggested by Strutinski.¹⁶ On the statistical theory, Strutinski has obtained the following expression for the angular distribution of the gamma rays:

$$n(\psi) = 1 + k_L (\hbar^2 J / IT)^2 \sin^2\psi, \quad (8)$$

where I and T are the moment of inertia and temperature of the fragment, respectively, and $k_L = 1/8, -3/8$ and $-81/64$ for $L=1$ (dipole), 2 (quadrupole), and 3 (octupole), respectively. From Eq. (8) for the observed anisotropy of 0.13, the average angular momentum $\langle J \rangle$ for the complete cascade is estimated to be about 11 units, assuming quadrupole emission, a rigid-body moment of inertia of the fragments of average mass 120 and temperature 0.4 MeV as estimated later from the spectral shape of the gamma rays. The angular momentum J_0 at the beginning of the cascade will be

¹⁶ V. M. Strutinskiĭ, Zh. Eksperim. i Teor. Fiz. **37**, 861 (1959) [translation: Soviet Phys.—JETP **10**, 613 (1960)].

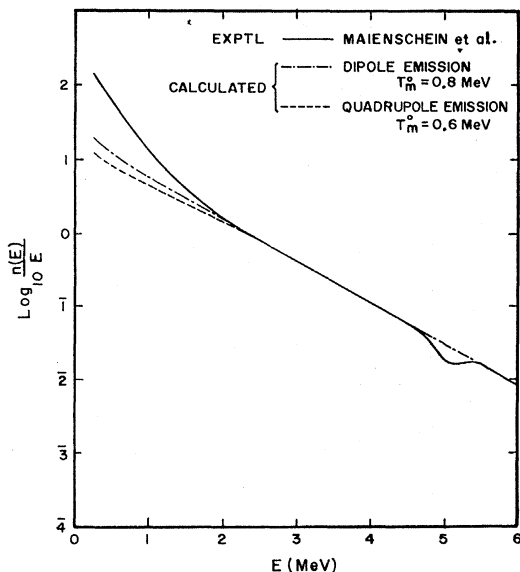

FIG. 5

FIG. 5. Spectrum of the fission gamma rays observed by Maienschein *et al.* and that calculated on the statistical theory for the cases of dipole and quadrupole emission using Eqs. (10) and (11), respectively.

higher than this average value $\langle J \rangle$ by a few units. The average angular momentum J_i with which the fragments are formed at the point of scission will be more than J_0 by a few units carried off by the evaporated neutrons; and, therefore, the value of J_i of about 20 units estimated by Strutinski appears reasonable on the basis of the present results. The observed enhanced emission of the gamma rays can, therefore, be associated with the fragment angular momentum, as due to the spin dependence of the level densities, especially during the late stages, the fragments may have to de-excite by gamma emission even if neutron emission were possible on energy consideration. The enhancement of the gamma-ray emission due to the presence of a high angular momentum of the nucleus has also been recently observed in direct experiments.^{17,18}

The observed number and the spectrum of the gamma rays suggests that some of the gamma rays are emitted in a process other than the statistical de-excitation of the fission fragments. On the statistical theory, the spectrum of the first gamma rays from a nucleus with temperature T is given by

$$W_L(E) = \text{const} E^{2L+1} \exp(-E/T). \quad (9)$$

Approximating the temperature distribution of the fragments after neutron emission to a linear distribution $P(T) = 2T/T_m^2$ up to a maximum temperature T_m on

¹⁷ J. F. Mollenauer, *Phys. Rev.* **127**, 867 (1962).

¹⁸ G. R. Choppin and T. J. Klingens, *Phys. Rev.* **130**, 1990 (1963).

the basis of earlier results¹¹ and taking into account the decreasing excitation energy of the fragments from initial average excitation to zero during the gamma cascade, the following expressions are obtained for the spectrum of the fission gamma rays for the two cases, assuming that the statistical theory is applicable at all the stages of the gamma emission. For dipole emission:

$$n_d(E)/E = \text{const} \left[\exp(-E/T_m^0) + \int_{E/T_m^0}^{\infty} \{\exp(-x)/x\} dx \right]. \quad (10)$$

For quadrupole emission:

$$n_q(E)/E = \text{const} \left[\{(E/T_m^0)^2 + (5E/T_m^0) + 11\} \times \{\exp(-E/T_m^0)\} + 6 \int_{E/T_m^0}^{\infty} \{\exp(-x)/x\} dx \right]. \quad (11)$$

T_m^0 is related to the average nuclear temperature \bar{T}_0 of the fragments at the beginning of the gamma emission by $\bar{T}_0 = \frac{2}{3} T_m^0$. The fission gamma-ray spectrum observed experimentally by Maienschein *et al.*,² along with the calculated spectra for the cases of dipole and quadrupole emission, is shown in Fig. 5. The fit to the high-energy part of the spectrum is found to be good for a value of $T_m^0 = 0.8$ MeV ($\bar{T}_0 = 0.53$ MeV), and $T_m^0 = 0.6$ MeV ($\bar{T}_0 = 0.4$ MeV) for dipole and quadrupole emission, respectively. However, at lower energies the calculated spectra for both the cases predict much lower yields than observed experimentally. For the same reason, the value of the number of the prompt gamma rays calculated on the statistical de-excitation process, in a manner similar to that outlined by Strutinski *et al.*¹⁹ in connection with capture gamma rays, is found to be much smaller than that observed experimentally. The higher yield of the low-energy gamma rays than calculated suggests that, in addition to the statistical de-excitation process, the gamma rays emitted at the later stages of the cascade originate from the de-excitation of the rotational states of the fragments, giving rise to more low-energy gamma rays.

ACKNOWLEDGMENTS

We express our sincere thanks to P. N. Rama Rao for his valuable help in carrying out the experiment. We are very much indebted to B. R. Ballal and S. R. S. Murthy for their help in many phases of the experimental work. Our thanks are due to D. M. Nadkarni for helpful discussions and to S. L. Raote for the construction of various electronic equipment.

¹⁹ V. M. Strutinski, L. V. Groshev, and M. K. Akimova, *Nucl. Phys.* **16**, 657 (1960).