

## High-Energy Gamma Radiation from Lithium Bombardment of $\text{Be}^9$ , $\text{B}^{10}$ , $\text{B}^{11}$ , and $\text{C}^{12}$ †

R. R. CARLSON AND M. THROOP  
*State University of Iowa, Iowa City, Iowa*  
 (Received 17 June 1964)

Gamma-ray spectra have been obtained with a 5- $\times$ 6-in. NaI(Tl) crystal for the bombardment of thick  $\text{Be}^9$ ,  $\text{B}^{10}$ ,  $\text{B}^{11}$ , and  $\text{C}^{12}$  targets with  $\text{Li}^6$  and  $\text{Li}^7$  beams. Intensities and source assignments are given for all gamma rays observed with an energy of 8 MeV or more. The probable gamma decay of the 9.83-MeV state in  $\text{N}^{15}$  was observed for several target-beam combinations. In the  $\text{Li}^6+\text{B}^{10}$  reaction, the population of the 9.17-MeV state in  $\text{N}^{14}$  and the 15.11-MeV state in  $\text{C}^{12}$  was observed. The population of these states is forbidden by isotopic-spin selection rules. For each reaction upper-limit total cross sections are about 1  $\mu\text{b}$  for the production of the compound nucleus with subsequent gamma decay. This indicates that compound nuclei are not formed to any significant degree in these reactions.

### INTRODUCTION

**G**AMMA rays from lithium bombardment of beryllium, boron, and carbon have been studied in this laboratory<sup>1</sup> in order to obtain information about the reaction mechanism in these heavy-ion nuclear reactions. The gamma rays have been found to be due to residual nuclei. These nuclei generally give a large yield of gamma rays of energy up to about 8 MeV, which is understandable since most of the residual nuclei become particle-unbound near this energy. There were indications, however, of a small yield of gamma rays of higher energy. The present work was done in order to determine the energies and intensities of these gamma rays, and to identify their source.

For those gamma rays whose sources are the residual nuclei, the yield of higher energy gamma radiation is of interest because the higher excitation states of the residual nuclei can have a quite different character from the low-lying states. If gamma decay of a state competes favorably with particle decay, it is possible to determine whether the state is formed by observation of gamma radiation. A characteristic of the state which might have an effect on its formation is its isotopic spin. Isotopic spins different from that of the ground state are usually at excitations where the residual nucleus is unbound. On the other hand, the isotopic spin of such a state implies certain restrictions on its particle decay so that observation of gamma decay may be possible.

For the target and beam combinations investigated, the  $Q$  values for formation of the compound nuclei were quite high. They ranged from 13.2 MeV for  $\text{Li}^6+\text{C}^{12}\rightarrow\text{F}^{18}$  to 30.9 MeV for  $\text{Li}^6+\text{B}^{10}\rightarrow\text{O}^{16}$ . Gains were set in this experiment so that de-excitation gamma rays from the compound nucleus could be observed, if present. From previous work, it was known that these gamma rays were present in very small intensities, if at all. It was felt that an upper limit on the intensity of compound-nucleus gamma rays would aid in understanding the reaction mechanism. With the excitation

available to the compound system lying in the region of the giant resonance, one would expect gamma-ray transition probabilities characteristic of dipole transitions and particle widths characteristic of a few nuclear transit times if the compound system were ever transformed into a compound nucleus. The ratio of the yield of very-high-energy gamma rays of energy up to 30 MeV to the yield of gamma rays below 8 MeV, which are due to residual nuclei, gives a value to be checked against the ratio of gamma and particle widths expected for compound nucleus formation. Cross sections were obtained also, both for low-energy gamma-ray production and, in the form of limits, for high-energy gamma-ray production.

### EXPERIMENTAL APPARATUS AND PROCEDURES

Thick targets of isotopically pure  $\text{Be}^9$ ,  $\text{B}^{10}$ ,  $\text{B}^{11}$ , and natural C were bombarded with  $\text{Li}^6$  and  $\text{Li}^7$  beams from the State University of Iowa 4-MeV Van de Graaff accelerator. The bombarding energy ranged from 2.7 to 3.8 MeV.

Spectra of the resulting gamma rays were obtained with a 5-in.-diam by 6-in.-long NaI(Tl) crystal located at 90 deg with respect to the incident beam. The crystal face was 3 in. away from the target and viewed it through a  $\frac{1}{4}$ -in.-thick Lucite window. All gamma rays passing through the crystal cross section at mid-length traversed only the Lucite window. The targets were oriented at 45° with respect to the beam, so that no gamma ray detected by the crystal had to pass through the target backing. The crystal was housed in a lead block of at least 4-in. thickness in directions parallel to the beam, as shown in Fig. 1. The lead shielding was necessary to eliminate the 15.1-MeV gamma ray produced from lithium bombardment of lithium-contaminated surfaces in the beam port, such as the control slits. The reaction responsible for the 15.1-MeV gamma-ray contamination is known to be  $\text{Li}^6+\text{Li}^7\rightarrow\text{C}^{12*}+n$ , with subsequent gamma decay from the 15.11-MeV state in  $\text{C}^{12}$ .<sup>2</sup> The lead shielding completely eliminated all gamma-ray contamination

† Work supported in part by National Science Foundation.

<sup>1</sup> E. Norbeck, S. A. Coon, R. R. Carlson, E. Berkowitz, and S. Bashkin, *Phys. Rev.* **130**, 1971 (1963).

<sup>2</sup> E. Berkowitz, S. Bashkin, R. R. Carlson, S. A. Coon, and E. Norbeck, *Phys. Rev.* **128**, 247 (1962).

TABLE I. Gamma-ray assignments and intensities.

Beam and target	Observed gamma-ray energy	Source	Relative intensity
$\text{Li}^6 + \text{Be}^9$	4.46	...	1
	8.1	$\text{B}^{11}$ 7.99 $\rightarrow$ 0	0.28
	8.9	$\text{B}^{11}$ 8.93 $\rightarrow$ 0	0.27
$\text{Li}^7 + \text{Be}^9$	5.10	...	1
	8.0	$\text{B}^{11}$ 7.99 $\rightarrow$ 0	0.065
	9.0	$\text{N}^{15}$ 9.06 $\rightarrow$ 0	0.12
	9.8	$\text{N}^{15}$ 9.83 $\rightarrow$ 0	0.075
$\text{Li}^6 + \text{B}^{10}$	10.8	$\text{N}^{15}$ 10.82 $\rightarrow$ 0	0.011
	5.10	...	1
	9.17	$\text{N}^{14}$ 9.17 $\rightarrow$ 0	0.013
	9.9	$\text{N}^{15}$ 9.83 $\rightarrow$ 0	0.0029
	10.8	$\text{N}^{15}$ 10.82 $\rightarrow$ 0	0.0016
	12.9-0.5	$\text{C}^{12}$ 12.71 $\rightarrow$ 0	0.0007
$\text{Li}^7 + \text{B}^{10}$	15.1-0.5	$\text{C}^{12}$ 15.11 $\rightarrow$ 0	0.0008
	6.8	...	1
	8.25	$\text{N}^{15}$ 8.32 $\rightarrow$ 0	0.15
	9.15	$\text{N}^{15}$ 9.16 $\rightarrow$ 0	0.31
	9.85	$\text{N}^{15}$ 9.83 $\rightarrow$ 0	0.07
	10.75	$\text{N}^{15}$ 10.82 $\rightarrow$ 0	0.014
$\text{Li}^6 + \text{B}^{11}$	15.1-0.5	$\text{C}^{12}$ 15.11 $\rightarrow$ 0	<0.018
	12.7-0.5	$\text{C}^{12}$ 12.71 $\rightarrow$ 0	<0.018
	6.90	...	1
$\text{Li}^7 + \text{B}^{11}$	9.25	$\text{N}^{15}$ 9.16 $\rightarrow$ 0	1.43
	10.0	$\text{N}^{15}$ 9.83 $\rightarrow$ 0	0.22
	10.8	$\text{N}^{15}$ 10.82 $\rightarrow$ 0	0.002
$\text{Li}^6 + \text{C}^{12}$	6.9	...	1
	9.1	$\text{N}^{16}$ 9.06 $\rightarrow$ 0	0.40
$\text{Li}^7 + \text{C}^{12}$	6.97	...	1
	9.1	$\text{N}^{14}$ 9.17 $\rightarrow$ 0	<0.0005
	See Ref. 1		

which had been observed in preliminary runs without shielding. An acetone-dry-ice cold trap was located on the beam pipe 15 in. from the target chamber.

A standard current integrator circuit recorded the total charge incident on the target. The accuracy of the integrated current values is estimated to be  $\pm 25\%$ .

Energy calibration for the gamma-ray spectrum was obtained by taking  $\text{Li}^6 + \text{Li}^7$  spectra before and after each run. The  $\text{Li}^6 + \text{Li}^7$  spectrum contains prominent peaks from gamma rays of energy equal to 4.46, 5.03, 6.84, 7.30, and 15.11 MeV.<sup>2</sup> Further calibration points were provided by the known gamma-ray spectrum below 8 MeV for each bombardment.<sup>1</sup> Usually a dozen or more points were available for the calibration of each spectrum. Errors in energy calibration are estimated to be less than  $\pm 0.2$  MeV for energies below 25 MeV.

Proof that the gamma-ray detection system was capable of detecting a 30-MeV gamma ray was obtained by observing the peak in the pulse-height distribution due to cosmic-ray mu mesons traversing the crystal. This peak occurred at 60 MeV.

In this experiment, gamma rays of energy greater than 8 MeV were generally of much smaller intensity than those below 8 MeV. In such a case, effects due to pulse pileup make observation of the low-intensity peaks difficult, even at low counting rates. It was therefore considered desirable to use a pileup discrimination

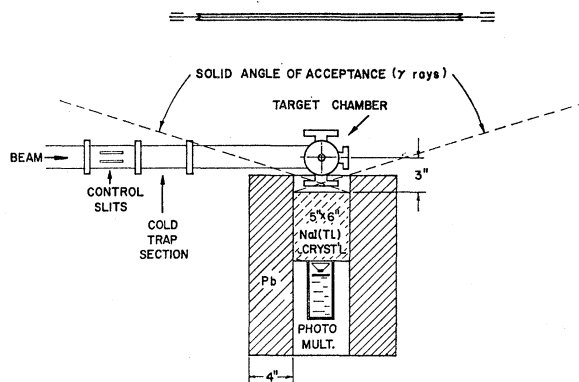

FIG. 1. Diagram of experimental geometry. Crystal was recessed in lead block so that no gamma rays produced in control slits or cold trap section could reach crystal except by scattering.

system as recently described by Strauss.<sup>3</sup> The system consisted of a Nuclear Data 256-channel analyzer, a Radiation Counter Laboratories A-61 amplifier, and a pileup detector and single-channel analyzer unit built, with minor parts changes, according to circuits given in Strauss' paper. The pileup discrimination system, although not 100% effective in eliminating pileup effects, improved the resolution of low-intensity gamma rays to a considerable degree.

The intensity analysis of the spectra above 8 MeV was performed by subtraction of standard line shapes. Calculated photofractions, efficiencies, and energy loss spectra were available for a 5-in.  $\times$  6-in. NaI(Tl) crystal located at 0 and 4 in. from a  $\frac{1}{4}$ -in.-diam beam spot, with gamma-ray energies ranging from 3 to 8 MeV. The method used to calculate these values is described by Miller and Snow.<sup>4</sup> Using such calculated values, the shape, photofraction, and efficiency were extrapolated for 8- to 15-MeV gamma rays as well. Errors in the value for the intensity of a given peak are about  $\pm 50\%$ . Table I contains assignments for all observed gamma rays above 8 MeV. The intensities are corrected for crystal efficiency and are referred to some prominent peak in each spectrum.

### $\text{Li}^6 + \text{Be}^9$

The data are given in Fig. 2.

The subtracted part of the spectrum at about 8.5 MeV can be decomposed into peaks at 8.9 and 8.1 MeV. These peaks are attributed to gamma decay from the 8.93- and 7.99-MeV levels in  $\text{B}^{11}$ , both of which have been observed to gamma decay in lithium-lithium reactions.<sup>2</sup> A three-parameter analysis of the  $\text{Li}^6 + \text{Be}^9$  reactions at this laboratory<sup>5</sup> has shown that the 8.57-MeV level in  $\text{B}^{11}$  is populated very slightly or not at all relative to the 7.99- and 8.93-MeV levels. The present data are consistent with this. No other peaks are

<sup>3</sup> M. G. Strauss, Rev. Sci. Instr. **34**, 335 (1963).

<sup>4</sup> W. F. Miller and W. J. Snow, Rev. Sci. Instr. **31**, 39 (1960).

<sup>5</sup> V. P. Hart (to be published).

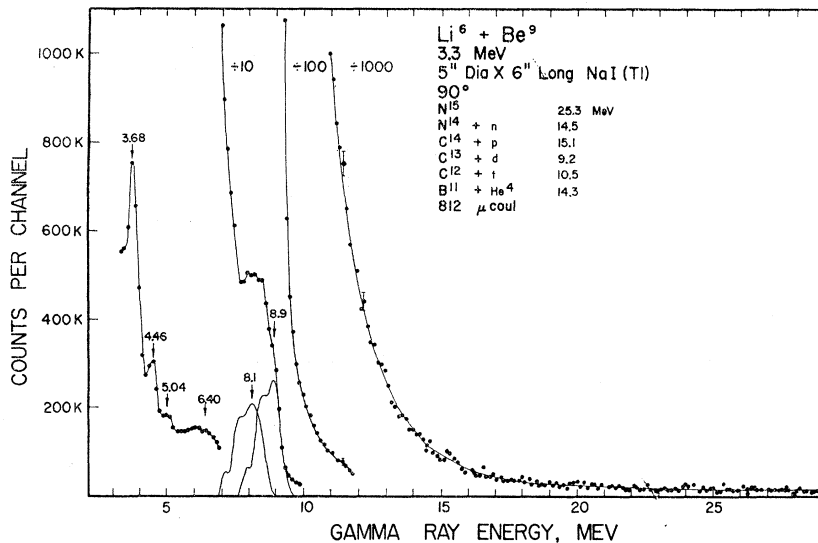

FIG. 2.  $\text{Li}^6 + \text{Be}^9$ , 3.3-MeV bombarding energy, 812  $\mu\text{C}$  of triply charged ion beam current.

observed above 9 MeV, although there is a very large continuum extending to about 18 MeV. The continuum is attributed to residual pileup.

### $\text{Li}^7 + \text{Be}^9$

The data are given in Fig. 3.

The subtracted part at about 9 MeV can be decomposed into peaks at 10.8, 9.8, 9.0, and 8.0 MeV. These are assigned to gamma decay from the 10.82-, 9.83-, and 9.06-MeV states in  $\text{N}^{15}$ , and the 7.99-MeV state in  $\text{B}^{11}$ , respectively. There is not enough excitation energy to produce the 8.93-MeV state in  $\text{B}^{11}$ .

The 9.8-MeV gamma ray, assigned to the 9.83-MeV state in  $\text{N}^{15}$ , occurs not only in this reaction, but in the  $\text{Li}^6 + \text{B}^{10}$ ,  $\text{Li}^7 + \text{B}^{10}$ ,  $\text{Li}^6 + \text{B}^{11}$ , and  $\text{Li}^7 + \text{C}^{12}$  reactions. This constitutes considerable evidence for the gamma decay of the 9.83-MeV state in  $\text{N}^{15}$ , which has only been observed in lithium reactions.

No peaks are observable above 10 MeV. As in the

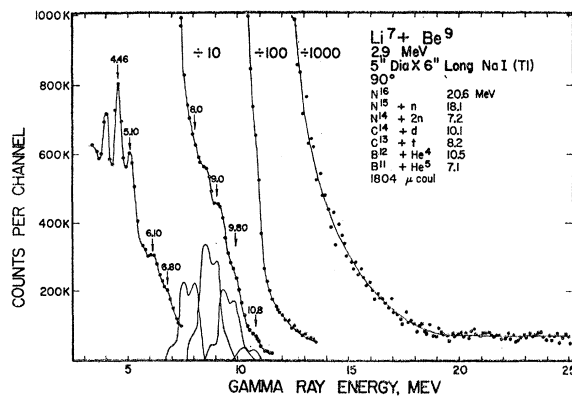

FIG. 3.  $\text{Li}^7 + \text{Be}^9$ , 2.9-MeV bombarding energy, 1804  $\mu\text{C}$  of triply charged ion beam current.

$\text{Li}^6 + \text{Be}^9$  spectrum, a large continuum extends to about 15 MeV. The production of  $\text{B}^{12}$  and  $\text{Li}^8$  occurs in this reaction, and the high-energy continuum is partly due to the beta decay from these two nuclei ( $E_{\text{max}}$  for both is about 13.5 MeV). However, a Kurie plot of the high-energy end of the spectrum deviates considerably from a straight line. As in  $\text{Li}^6 + \text{Be}^9$  spectrum, part of the spectrum must be attributed to pileup effects.

### $\text{Li}^6 + \text{B}^{10}$

The data are given in Fig. 4.

Gamma-ray peaks are to be seen at 15.1–0.5, 12.9–0.5, 10.8, 9.9, and 9.17 MeV, and are attributed to states in  $\text{C}^{12}$  (15.11 and 12.71 MeV),  $\text{N}^{15}$  (10.82 and 9.83 MeV), and  $\text{N}^{14}$  (9.17 MeV). The 15.1- and 12.7-MeV gamma rays from  $\text{C}^{12}$  are also observed in the  $\text{Li}^6 + \text{Li}^7$  calibration spectrum. A three-parameter analysis of the  $\text{Li}^6 + \text{B}^{10}$  reaction at this laboratory has shown that the 9.17-MeV gamma ray is due to the 9.17-MeV state in  $\text{N}^{14}$ .<sup>6</sup> The significance of the population of the  $\text{C}^{12}$  and  $\text{N}^{14}$  states is discussed below.

### $\text{Li}^7 + \text{B}^{10}$

The data are shown in Fig. 5.

Gamma-ray peaks are to be seen at 10.75, 9.85, 9.15, and 8.25 MeV, and are attributed to the 10.82-, 9.83-, 9.16-, and 8.32-MeV states in  $\text{N}^{15}$ . The present results are in agreement with the previously observed high-energy gamma rays.<sup>1</sup>

Proton contamination of the targets, due to diffusion-pump oil vapor, resulted in the reaction  $\text{Li}^7 + p \rightarrow \text{Be}^{8*}$ , with 17.6- and 14.7-MeV gamma rays from  $\text{Be}^8$ . The  $\text{Li}^7$  bombarding energy must be greater than 3 MeV for the reaction to occur, so only the  $\text{Li}^6 + \text{B}^{10}$ ,  $\text{B}^{11}$ , and

<sup>6</sup> R. R. Carlson, Proceedings of the Paris Conference, 1964 (unpublished).

FIG. 4.  $\text{Li}^6 + \text{B}^{10}$ , 3.8-MeV bombarding energy, 301  $\mu\text{C}$  of triply charged ion beam current.

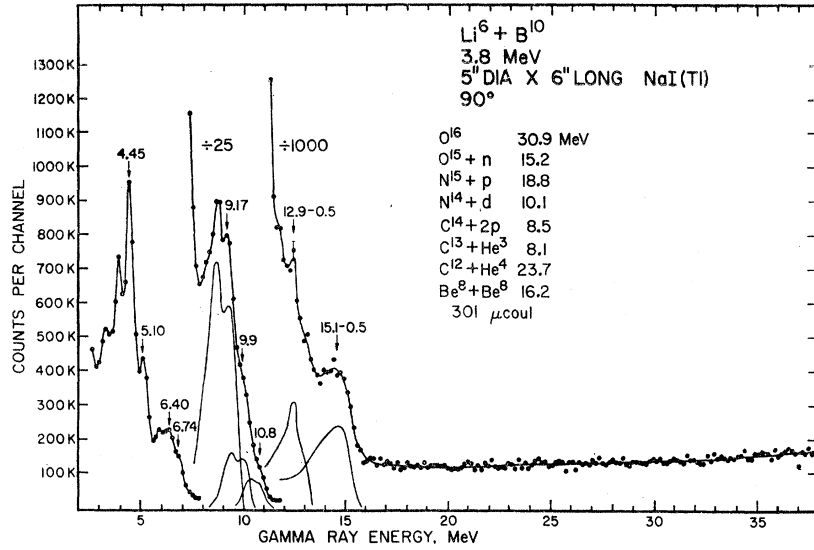
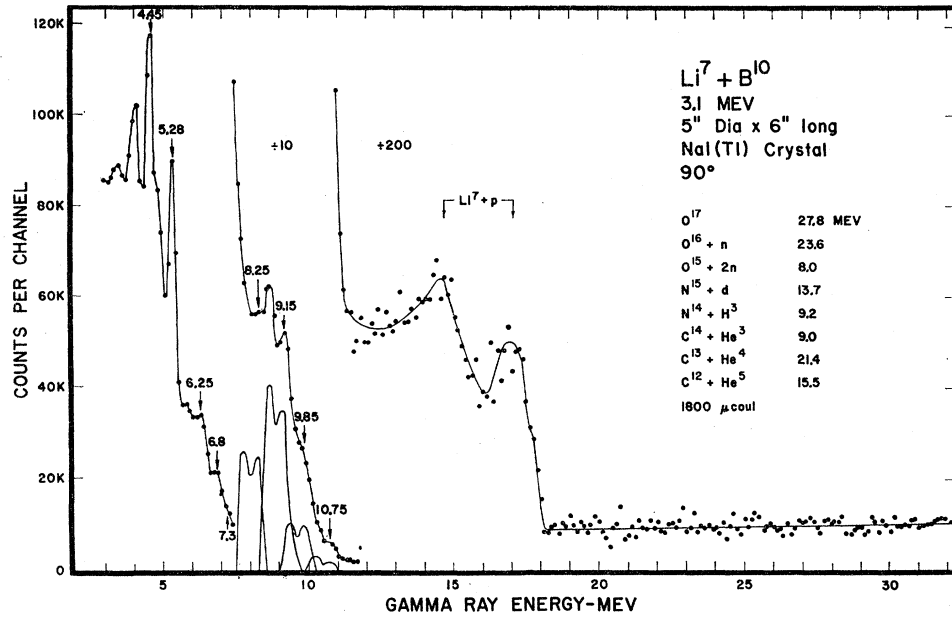

FIG. 5.  $\text{Li}^7 + \text{B}^{10}$ , 3.1-MeV bombarding energy, 1800  $\mu\text{C}$  of triply charged ion beam current.



$\text{C}^{12}$  spectra show the 17.6- and 14.7-MeV gamma rays. In the  $\text{Li}^7 + \text{B}^{10}$  case, the production of  $\text{C}^{12}$  in the 15.1- and 12.7-MeV states is energetically possible. The shape and intensity of proton-contamination gamma-ray peaks from a known amount of beam current on the target frame matched that of the  $\text{Li}^7 + \text{B}^{10}$  spectrum within statistical error. Therefore, no evidence is present for the production of the  $\text{C}^{12}$  15.1- and 12.7-MeV states. An upper limit for the intensity of these gamma rays is given in Table I.

$\text{Li}^6 + \text{B}^{11}$

The data are given in Fig. 6. Gamma-ray peaks are to be seen at 10.8, 10.0, and 9.25 MeV, and are assigned to the 10.82-, 9.83-, and

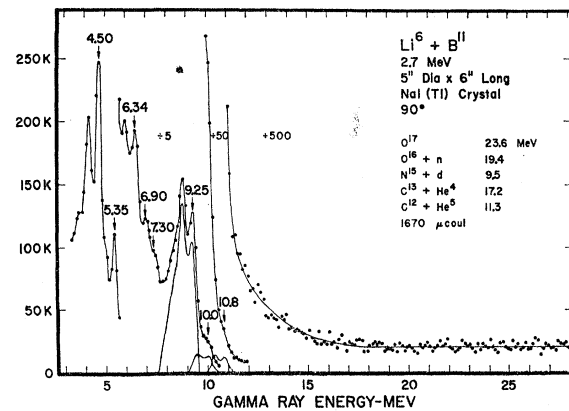

FIG. 6.  $\text{Li}^6 + \text{B}^{11}$ , 2.7-MeV bombarding energy, 1670  $\mu\text{C}$  of triply charged ion beam current.

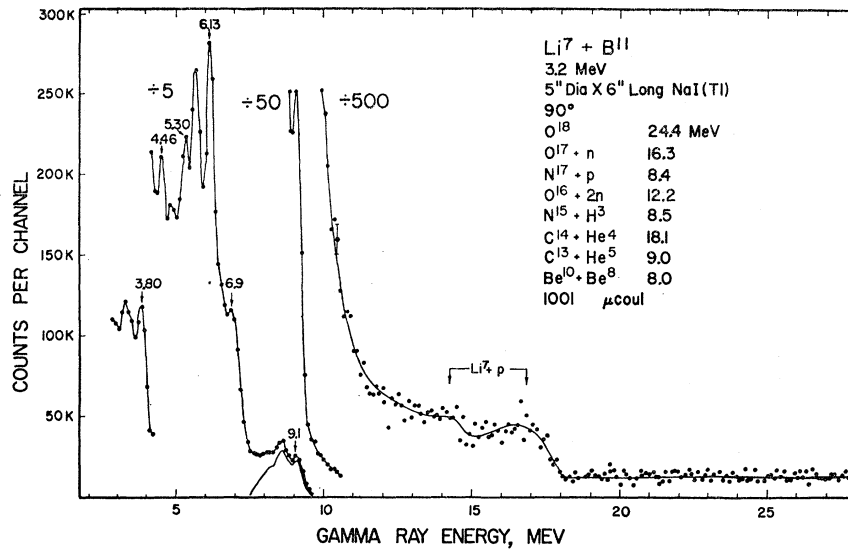

FIG. 7. Li<sup>7</sup>+B<sup>11</sup>, 3.2-MeV bombarding energy, 1001 μC of triply charged ion beam current.

9.16-MeV states in N<sup>15</sup>. There is no evidence for the population of the 12.71-MeV state in C<sup>12</sup>, which is energetically accessible.

The remarkable similarity between the Li<sup>7</sup>+B<sup>10</sup> and Li<sup>6</sup>+B<sup>11</sup> spectra has been noted before.<sup>1</sup> The present results extend the similarity to the high-energy part of the spectrum.

### Li<sup>7</sup>+B<sup>11</sup>

The data are shown in Fig. 7.

The gamma-ray peak is assigned to either the 9.06- or the 9.16-MeV level in N<sup>15</sup>. The peaks at 14.7 and 17.6 MeV are due to proton contamination.

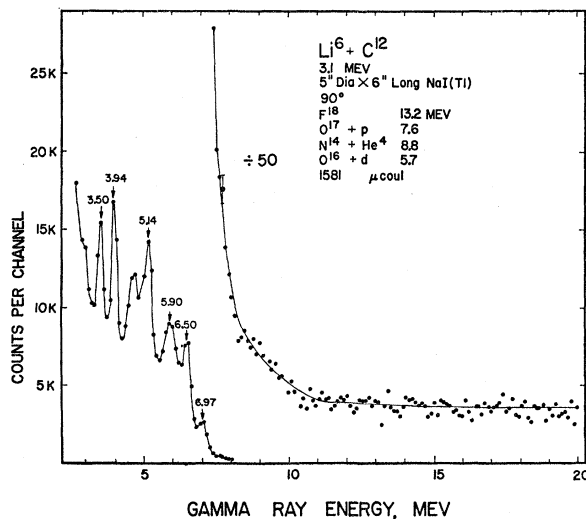

FIG. 8. Li<sup>6</sup>+C<sup>12</sup>, 3.1-MeV bombarding energy, 1581 μC of triply charged ion beam current.

### Li<sup>6</sup>+C<sup>12</sup>

The data are shown in Fig. 8.

In this reaction, as for Li<sup>6</sup>+B<sup>10</sup>, isotopic-spin selection rules prohibit the formation of the 9.17-MeV ( $T=1$ ) state in N<sup>14</sup>. The Li<sup>6</sup>+C<sup>12</sup> reaction populates this state very little or not at all, in striking contrast to the Li<sup>6</sup>+B<sup>10</sup> reaction. Very slight evidence is present for a gamma ray about 9 MeV. The probable source is the 9.17-MeV state in N<sup>14</sup>. An upper limit is set in Table I for the intensity of this peak.

This spectrum indicates that a 7.4-MeV peak, if present at all, must be less than one-tenth the intensity of the 6.97-MeV peak. In a previous analysis of the Li<sup>6</sup>+C<sup>12</sup> spectrum,<sup>1</sup> taken at nearly the same bombarding energy as the present one, gamma decay from the 7.40-MeV state in N<sup>14</sup> was considered to be a source for an observed 2.5-MeV gamma ray, where the branching ratio was required to be 7.40 → 4.90, 80%. The present data indicate that either the 7.40-MeV state in N<sup>14</sup> is not produced at all or the branching ratio must be 7.40 → 0, <5% and 7.40 → 4.90, >95%. The 2.5-MeV peak could not be observed, so the 6.97-MeV peak was used as a measure of the 2.5-MeV intensity relative to that of the 7.40-MeV peak.

### Li<sup>7</sup>+C<sup>12</sup>

The data are shown in Fig. 9.

No new gamma rays above 8 MeV are observed. Those at 9.17 and 9.86 MeV have been assigned to the 9.16- and 9.83-MeV states in N<sup>15</sup>.<sup>1</sup> The peaks at 14.7 and 17.6 MeV are due to proton contamination.

### VIOLATION OF ISOTOPIC-SPIN SELECTION RULES

The formation of isotopic-spin-one states in Li<sup>6</sup>+B<sup>10</sup> reactions is forbidden by isotopic-spin selection rules<sup>7</sup>

<sup>7</sup> R. K. Adair, Phys. Rev. 87, 1041 (1952).

since both  $\text{Li}^6$  and  $\text{B}^{10}$  ground states are reasonably pure  $T=0$  states.<sup>8</sup> In the following two reactions, consequently, only  $T=0$  states should be formed:

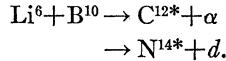

Since both the  $\text{C}^{12}$  15.1-MeV ( $T=1$ ) and  $\text{N}^{14}$  9.17-MeV ( $T=1$ ) states are observed to be populated, we have an indication of violation of isotopic-spin selection rules for these two reactions. This effect has previously been observed for lithium reactions. The 2.31-MeV state of  $\text{N}^{14}$  ( $T=1$ ) has been shown to be populated to a slight extent in the  $\text{Li}^6 + \text{C}^{12} \rightarrow \text{N}^{14*} + \alpha$  reaction at a bombarding energy of 4.0 MeV, where only  $T=0$  states in  $\text{N}^{14}$  are allowed by isotopic-spin rules.<sup>9</sup>

The formation of isotopic-spin-forbidden  $T=1$  states in  $\text{N}^{14}$  will be the subject of a forthcoming paper based on a three-parameter analysis of the  $\text{Li}^6 + \text{B}^{10} \rightarrow \text{N}^{14} + d$  reaction.<sup>6</sup> It should be noted that the population of the 9.17-MeV state is quite large, as indicated by the prominence of the gamma-ray peak.

In the case of  $\text{C}^{12*}$  formation, both the 12.71 ( $T=0$ ) and 15.11-MeV ( $T=1$ ) states are observed in nearly equal intensity, although the formation of the latter is prohibited. The fractional widths  $\Gamma_\gamma/\Gamma$  for gamma decay are  $0.02 \pm 0.01$  for the 12.71-MeV state and  $0.69 \pm 0.07$  for the 15.11-MeV state.<sup>10</sup> Taking into account the branching ratios for gamma decay to the 4.43-MeV and ground state in  $\text{C}^{12}$ ,<sup>10,11</sup> as well as the relative intensities from Table I, the population of the forbidden 15.11-MeV state is about  $3 \pm 2\%$  of the allowed 12.71-MeV state.

It is conceivable that isotopic-spin mixing of neighboring levels in the compound nucleus could account for  $\text{N}^{14}$  and  $\text{C}^{12}$   $T=1$  states being populated. However, the  $\text{O}^{16}$  compound nucleus excitation at 3.8-MeV bombarding energy is 33.3 MeV, and such a highly excited compound nucleus is unlikely to last long enough for mixing to occur.

Both  $(\alpha, \alpha')$  and  $(d, d')$  scattering from  $\text{C}^{12}$  have shown no indication of gamma rays from the 15.11-MeV ( $T=1$ ) state of  $\text{C}^{12}$ , and upper limits of  $4 \times 10^{-3}$  for  $(d, d')$  and  $10^{-3}$  for  $(\alpha, \alpha')$  have been set for a  $T=0$  admixture.<sup>12,13</sup> It therefore seems unlikely that the observed population of the 15.11-MeV state in this reaction can be explained by a  $T=0$  admixture, since such an admixture is observed to be too small.

An explanation can be sought in the fact that the reaction proceeds with a classical distance of closest approach (15 F) which is 2.5 times the sum of the

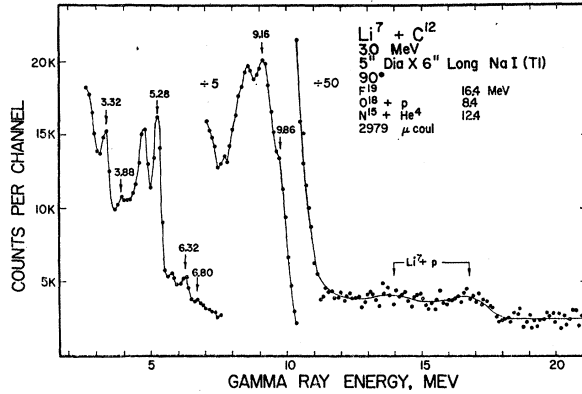

FIG. 9.  $\text{Li}^7 + \text{C}^{12}$ , 3.0-MeV bombarding energy, 2979  $\mu\text{C}$  of triply charged ion beam current.

nuclear radii (6 F). Under these conditions, the dominant potential should be the Coulomb potential. A change in isotopic spin would therefore be possible just as in the case of an electromagnetic transition. In other words, isotopic spin would not be conserved under the conditions of these reactions.

#### COMPOUND-NUCLEUS GAMMA RAYS

For each bombardment, gains were set so that it would be possible to observe high-energy gamma rays from compound nuclei formed in the general reaction  $\text{Li} + \text{target nucleus} \rightarrow \text{compound nucleus}$ . De-excitation of the compound nucleus by gamma decay releases an energy equal to  $Q + E_{e.m.}$ . The excitation energies for such reactions in this experiment ranged from 15.3 MeV for  $\text{Li}^6 + \text{C}^{12} \rightarrow \text{F}^{18*}$  to 33.3 MeV for  $\text{Li}^6 + \text{B}^{10} \rightarrow \text{O}^{16*}$ . Gamma rays from the compound nucleus were not observed for any target-beam combination. Upper limits, in counts per microcoulomb, are given in Table II. The upper-limit cross section has also been computed for Table II, using the formula

$$Y = N_t \int_0^{E_b} \frac{\sigma P}{dE/dx} dE \epsilon d\Omega,$$

where  $Y$  = yield of gamma rays per bombarding ion,

TABLE II. Upper-limit yields and cross sections for compound-nucleus formation and subsequent gamma decay.

Beam-target combination	Yield, in counts per $\mu\text{coulomb}$ of triply charged beam	Cross section $\mu\text{b}$	Bombarding energy, MeV	Compound-nucleus excitation, MeV
$\text{Li}^6 + \text{Be}^9 \rightarrow \text{N}^{16*}$	<0.17	<1.4	3.3	27.0
$\text{Li}^7 + \text{Be}^9 \rightarrow \text{N}^{16*}$	<0.12	<0.5	2.9	22.2
$\text{Li}^6 + \text{B}^{10} \rightarrow \text{O}^{16*}$	<1.2	<1.4	3.8	33.3
$\text{Li}^7 + \text{B}^{10} \rightarrow \text{O}^{17*}$	<0.10	<0.6	3.1	29.6
$\text{Li}^6 + \text{B}^{11} \rightarrow \text{O}^{17*}$	<0.09	<1.0	2.7	25.4
$\text{Li}^7 + \text{B}^{11} \rightarrow \text{O}^{18*}$	<0.15	<0.6	3.2	26.4
$\text{Li}^6 + \text{C}^{12} \rightarrow \text{F}^{18*}$	<0.08	<0.5	3.1	15.3
$\text{Li}^7 + \text{C}^{12} \rightarrow \text{F}^{19*}$	<0.04	<0.15	3.0	18.3

<sup>8</sup> W. M. MacDonald, Phys. Rev. **101**, 271 (1956).

<sup>9</sup> R. K. Hobbie and F. F. Forbes, Phys. Rev. **126**, 2137 (1962).

<sup>10</sup> E. Almquist, D. A. Bromley, A. J. Ferguson, H. E. Gove, and A. E. Litherland, Phys. Rev. **114**, 1040 (1959).

<sup>11</sup> D. E. Alburger and R. E. Pixley, Phys. Rev. **119**, 1970 (1960).

<sup>12</sup> C. N. Waddell, H. E. Adelson, B. J. Moyer, and H. C. Shaw, Bull. Am. Phys. Soc. **2**, 181 (1957).

<sup>13</sup> C. N. Waddell, Ph.D. thesis, University of California, UCRL 3901, 1957 (unpublished).

TABLE III. Total gamma-ray yield and cross sections  $\geq 3$  MeV.

Beam and target	Bombarding energy MeV	Gamma-ray yield $\geq 3$ MeV counts per $\mu\text{coulomb}$ of triply charged beam	Gamma-ray cross section $\geq 3$ MeV (mb)	Minnesota particle cross section, $E_\gamma \geq 3$ MeV (mb)
Li <sup>6</sup> +Be <sup>9</sup>	3.3	$7.8 \times 10^8$	18	8.18 <sup>a</sup>
Li <sup>7</sup> +Be <sup>9</sup>	2.9	$12 \times 10^8$	13	
Li <sup>6</sup> +B <sup>10</sup>	3.8	$38 \times 10^8$	12	
Li <sup>7</sup> +B <sup>10</sup>	3.1	$1.3 \times 10^9$	2.2	
Li <sup>6</sup> +B <sup>11</sup>	2.7	$2.2 \times 10^8$	5.7	
Li <sup>7</sup> +B <sup>11</sup>	3.2	$2.9 \times 10^8$	3.3	
Li <sup>6</sup> +C <sup>12</sup>	3.1	$0.37 \times 10^8$	0.64	0.8 <sup>b</sup>
Li <sup>7</sup> +C <sup>12</sup>	3.0	$0.20 \times 10^8$	0.20	0.16 <sup>c</sup>

<sup>a</sup> Total cross section for production of 4.46-, 5.03-, 6.76-, 6.81-, 7.30-, and 7.99-MeV states in B<sup>11</sup> at  $E_{Li^6} = 3.3$  MeV. From Ref. 15.  
<sup>b</sup> Total cross section for production of 3.85-MeV state in O<sup>17</sup> and 3.95-MeV state in N<sup>14</sup> extrapolated to  $E_{Li^6} = 3.1$  MeV. From Ref. 16.  
<sup>c</sup> Total cross section for production of 5.28-, 5.30-, and 6.33-MeV states in N<sup>14</sup>, extrapolated to  $E_{Li^7} = 3.0$  MeV. From Ref. 9.

$N_i = (\text{No. of target particles})/cc$ ,  $P$  is the ratio of the WKB penetrability at energy  $E$  to that at bombarding energy  $E_b$ , and  $dE/dx$  is the stopping power for Li ions in the target, derived from  $dE/dx$  curves for Li in air.<sup>14</sup>  $\epsilon$  is the crystal efficiency extrapolated from the data of Miller and Snow,<sup>4</sup> and  $d\Omega$  is the solid angle subtended by the crystal. Within the  $\pm 50\%$  accuracy of the cross-section results, the angular distribution of gamma rays is known to be isotropic. The integration was performed by evaluating the integrand at 0.5-MeV intervals and summing.

Table III gives the cross section, as well as the yield, in counts per microcoulomb for gamma rays of energy greater than 3 MeV for each target-beam combination.

If the reactions studied in this experiment proceed through compound nucleus formation, then

$$\Gamma_\gamma/\Gamma_{p\pm 1} = \sigma_{c\gamma}/\sigma_T,$$

where  $\Gamma_\gamma$ ,  $\Gamma_{p\pm 1}$  are the widths for gamma and particle decay of the excited compound nucleus and  $\sigma_{c\gamma}$  and  $\sigma_T$  are the cross sections for gamma rays from compound-nucleus de-excitation and for particle breakup of the compound nucleus.

$\Gamma_\gamma$  is computed from the Weisskopf formula for an  $E1$  transition. The energy of the gamma ray is taken to be about 20 MeV, since there should be a sufficiently

low-lying level in the compound nucleus with spin and parity such that an  $E1$  transition is possible.  $\Gamma_{p\pm 1}$  is taken as about 1 MeV, a reasonable value for highly excited states of light nuclei. The ratio of  $\sigma_{c\gamma}/\sigma_T$  is from Table II, where  $\sigma_T$  is replaced by  $\sigma_{T\gamma}$ , the cross section for gamma rays above 3 MeV. The latter value is too small because it does not include contributions for the production of the ground state and gamma rays of less than 3 MeV from the residual nuclei, so we have

$$\Gamma_\gamma/\Gamma_{p\pm 1} \leq \sigma_{c\gamma}/\sigma_{T\gamma}.$$

The left-hand side is  $3 \times 10^{-3}$ . The experimental yield ratios range from  $0.8 \times 10^{-3}$  for Li<sup>7</sup>+C<sup>12</sup> to  $0.04 \times 10^{-3}$  for Li<sup>7</sup>+Be<sup>9</sup>. The data are clearly not consistent with compound-nucleus formation as a dominant reaction mechanism.

In Table III a comparison is made, where possible, between the  $\geq 3$ -MeV gamma-ray cross-section data and particle cross-section work done at the University of Minnesota.<sup>9,15,16</sup> There is fair agreement between the two, although the particle cross-section data are incomplete. The gamma-ray cross sections values are accurate to  $\pm 50\%$ .

## CONCLUSIONS

The high-energy gamma rays observed in this experiment have been identified as being due to decay primarily from states in N<sup>15</sup>, as well as from B<sup>11</sup>, C<sup>12</sup>, and N<sup>14</sup>. The results indicate that the 9.83-MeV state in N<sup>15</sup> is populated and gamma decays to the ground state in the Li<sup>7</sup>+Be<sup>9</sup>, Li<sup>6</sup>+B<sup>10</sup>, Li<sup>7</sup>+B<sup>10</sup>, Li<sup>6</sup>+B<sup>11</sup>, and Li<sup>7</sup>+C<sup>12</sup> reactions.

The upper-limit cross sections for compound-nucleus formation with subsequent gamma decay are about  $1 \mu\text{b}$  for each reaction. These cross-section results, combined with those for all gamma rays above 3 MeV, indicate that the reactions studied do not proceed significantly by compound-nucleus formation.

Population of the 9.17-MeV state in N<sup>14</sup> and the 15.11-MeV state in C<sup>12</sup> were observed in the Li<sup>6</sup>+B<sup>10</sup> reaction, although the population of both is forbidden by isotopic-spin selection rules. Since the initial and final states are relatively pure isotopic-spin states, there is an indication that isotopic spin is not conserved in this low-energy heavy-ion reaction.

<sup>14</sup> S. A. Teplova, I. S. Dimitriev, V. S. Nikolaev, and L. N. Fateeva, Zh. Eksperim. i Teor. Fiz. 32, 974 (1957) [English transl.: Soviet Phys.—JETP 5, 797 (1957)].

<sup>15</sup> R. K. Hobbie, C. W. Lewis, and J. M. Blair, Phys. Rev. 124, 1506 (1961).

<sup>16</sup> J. M. Blair and R. K. Hobbie, Phys. Rev. 128, 2282 (1962).