

## METAL-BORON INTERACTIONS IN BORON-SUBSTITUTED FERROCENES, RUTHENOCENES AND OSMOCENES

BERND WRACKMEYER,\* UDO DÖRFLER, WOLFGANG MILIUS and  
 MAX HERBERHOLD\*

Laboratorium für Anorganische Chemie, Universität Bayreuth, D-95440 Bayreuth,  
 Germany

(Received 18 August 1994; accepted 7 October 1994)

**Abstract**—Direct iron-boron bonding interactions in ferrocenylboranes can be deduced from the single crystal X-ray structure determination of 1,1'-bis(dibromoboryl)ferrocene (**1**; triclinic, space group  $P\bar{1}$ ). The molecule **1** is centrosymmetric and both C(1)—B and C(1a)—B bonds are bent by  $10.2^\circ$  with respect to the planes of their cyclopentadienyl rings towards the iron atom. This particular structural feature is not observed in 1,1'-bis[bis(diisopropylamino)boryl]ferrocene (**2**; monoclinic, space group  $P2_1/n$ ) nor in other known structures of ferrocenylboranes. The boryl groups must be strong Lewis acidic centres such as in **1** in order to induce Fe—B bonding, comparable with Fe—C $^\alpha$  interactions in  $\alpha$ -ferrocenyl carbocations. Since in  $\alpha$ -metallocenyl carbocations Fe—C $^\alpha$  bonding is much weaker than Ru—C $^\alpha$  and Os—C $^\alpha$ , the  $\delta^{11}\text{B}$  values of borylation products obtained from the reaction between ruthenocene and  $\text{BX}_3$  (X = Cl, Br, I) and osmocene and  $\text{BBr}_3$  serve as an argument for M—B bonding analogous to  $\delta^{13}\text{C}(\text{C}^\alpha)$  for M—C $^\alpha$  bonding. In the dihalogenoboryl-substituted ruthenocenes (**3–13**) and osmocenes (**14–17**) Ru—B and, in particular, Os—B bonding interactions are strong, as indicated by markedly increased  $^{11}\text{B}$  nuclear shielding relative to that in the corresponding ferrocenes or phenylboron dihalides.

$\alpha$ -Metallocenyl carbocations have been extensively studied, and their increased stability as compared with phenyl carbocations has been ascribed to the metal—C $^\alpha$  interaction, which becomes increasingly important in the series M = Fe, Ru and Os.<sup>1,2</sup> This interaction is indicated by the angle  $\beta$  (see Scheme 1) between the plane of the cyclopentadienyl ring and the direction of the C(1)—C $^\alpha$  bond and, in particular for M = Ru and Os, by short M—C $^\alpha$  distances.<sup>1,2</sup> Carbocations and boranes are isoelectronic and possess analogous structures in most cases. Their NMR parameters, e.g.  $\delta^{11}\text{B}$  and  $\delta^{13}\text{C}(\text{C}^\alpha)$  values, are comparable and display analogous substituent effects.<sup>3</sup> It has been noted that  $\delta^{11}\text{B}$  of ferrocenyldimethylborane ( $\text{Fc—BMe}_2$ ) and  $\delta^{13}\text{C}(\text{C}^\alpha)$  of the corresponding carbocation  $[\text{Fc—CMe}_2]^+$  do not fit into  $\delta^{11}\text{B}/\delta^{13}\text{C}(\text{C}^\alpha)$  correlations,<sup>3c</sup> possibly because significant Fe—B

interactions are absent in the borane. NMR data of a series of ferrocenylboranes have led to the conclusion<sup>4</sup> that Fe—B interactions are unlikely ( $\beta = 0^\circ$ ), in contrast to M—C $^\alpha$  interactions in isoelectronic  $\alpha$ -ferrocenyl carbocations. The few structural data available for ferrocenylboranes appear to confirm this view, since deviations from  $\beta = 0$  in triferrocenylborane<sup>5</sup> and also in  $B, B', B''$ -triferrocenylboraselenine<sup>6</sup> are negligible.

In order to induce direct M—B bonding inter-

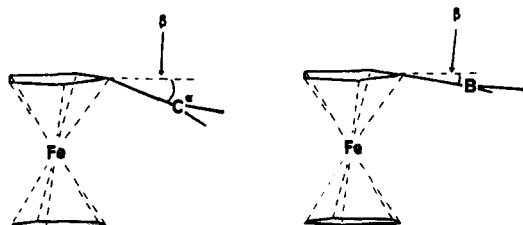

Scheme 1.

\* Authors to whom correspondence should be addressed.

actions, the boron atom must be a strong Lewis acidic centre. This condition is met in 1,1'-bis(di-bromoboryl)ferrocene (**1**), and we report here on its molecular structure as determined by single crystal X-ray analysis. Furthermore, 1,1'-bis[bis(diisopropylamino)boryl]ferrocene (**2**) was prepared in which the boryl groups are rather weak Lewis acids. The molecular structure of **2** was also determined by X-ray analysis. Since M—C<sup>z</sup> bonding is stronger for M = Ru and Os than for M = Fe, the same should be true for Ru—B, Os—B and Fe—B interactions. Therefore, it was hoped that NMR spectroscopic data of the previously unknown borylated ruthenocenes **3–13** and osmocenes **14–17** could shed some light on this problem.

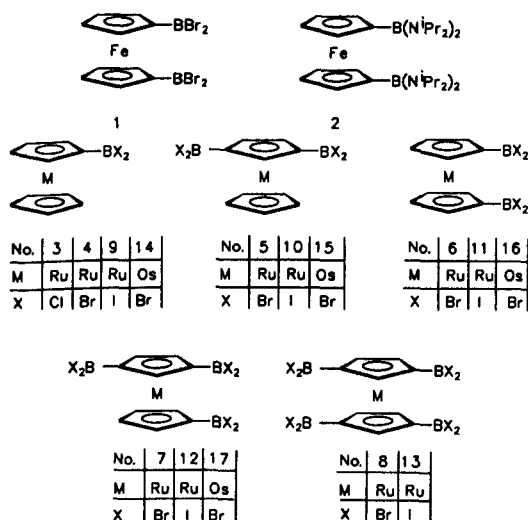

## RESULTS AND DISCUSSION

### Syntheses

Direct borylation of ferrocene with  $\text{BBr}_3$  affords **1**<sup>7,8</sup> [eq. (1)]. The aminolysis of **1** in the presence of an excess of diisopropylamine does not lead to **2** but selectively to 1,1'-bis[(diisopropylamino)bromoboryl]ferrocene. An alternative route to **2** was found in the reaction between 1,1'-dilithioferrocene<sup>9</sup> and two equivalents of bis-(diisopropylamino)chloroborane [eq. (2)]. The

\* Further details of the crystal structure analyses are available on request from the Fachinformationszentrum Karlsruhe, Gesellschaft für wissenschaftlich-technische Information mbH, D-76344 Eggenstein-Leopoldshafen (Germany) on quoting the depository numbers CSD 401,308 (**1**) and CSD 401,307 (**2**), the names of the authors and the journal citation.

borylation of ruthenocene with  $\text{BCl}_3$ ,  $\text{BBr}_3$  (Scheme 2) and  $\text{BI}_3$  proceeds in a similar way as described for ferrocene.<sup>4,7,8</sup> In the case of ruthenocene, the reaction with  $\text{BCl}_3$  yields cleanly the mono-substitution product **3**, whereas with  $\text{BBr}_3$  mixtures of **4**, **5** and **6** are always generated in the attempt to obtain either **4** or **6** in the pure state. Compounds **7** and **8** become dominant in the reaction mixture if a large excess of  $\text{BBr}_3$  is present. The reaction of ruthenocene with  $\text{BI}_3$  proceeds in the same way as with  $\text{BBr}_3$  (see Scheme 2). It must be noted that decomposition of **4–13** takes place more readily as in the case of ferrocenes. The borylation of osmocene with  $\text{BBr}_3$  also affords mixtures in addition to insoluble white unidentified side products. The ruthenocene (**3–13**) and osmocene derivatives (**14–17**) were characterized by  $^1\text{H}$ ,  $^{11}\text{B}$  and  $^{13}\text{C}$  NMR spectroscopy (see Table 1).

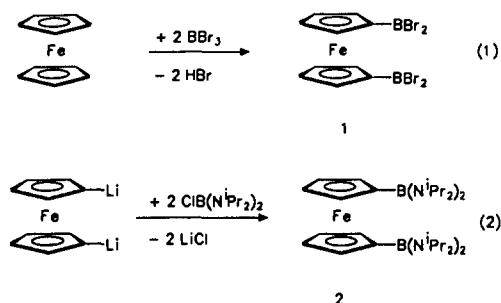

### X-ray analyses

Data related to the X-ray structure determinations of **1** and **2** are given in Table 2\*. The molecular structures of **1** and **2** are shown in Figs

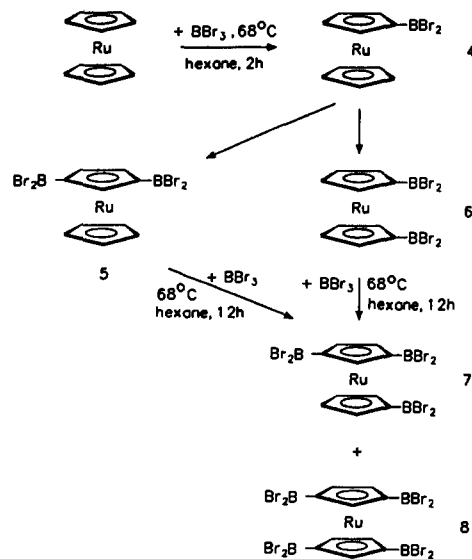

Scheme 2.

Table 1.  $^1\text{H}$ ,  $^{11}\text{B}$  and  $^{13}\text{C}$  NMR data<sup>a</sup> of boron-substituted ferrocenes **1** and **2**, ruthenocenes **3–13**, and osmocenes **14–17**

No.	M	X	$\delta^{11}\text{B}$	$\delta^{13}\text{C}$ ( $\delta^1\text{H}$ )				
				C(2)	C(3)	C(4)	C(5)	$\text{C}_5\text{H}_5$
<b>1</b> <sup>b</sup>	Fe	Br	+50.0	78.9 (4.63)	80.3 (4.86)	80.3 (4.86)	78.9 (4.63)	
<b>2</b> <sup>c</sup>	Fe		+34.8	76.0 (4.33)	71.7 (4.29)	71.7 (4.29)	76.0 (4.33)	
<b>3</b> <sup>d</sup>	Ru	Cl	+44.4	77.8 (4.60)	78.6 (4.71)	78.6 (4.71)	77.8 (4.60)	74.8 (4.28)
<b>4</b> <sup>d</sup>	Ru	Br	+34.5	79.8 (4.61)	79.9 (4.65)	79.9 (4.65)	79.8 (4.61)	76.3 (4.26)
<b>5</b>	Ru	Br	n.o.	85.3 (5.16)	n.o.	83.2 (4.95)	83.2 (4.95)	78.2 (4.15)
<b>6</b>	Ru	Br	+44.3	81.6 (4.60)	83.3 (4.49)	83.3 (4.49)	81.6 (4.60)	
<b>7</b> <sup>d</sup>	Ru	Br	+49.5	87.6 (5.11)	n.o.	87.0 (4.86)	87.0 (4.86)	
			+49.5	83.5 (4.53)	83.4 (4.35)	83.4 (4.35)	83.5 (4.53)	
<b>8</b>	Ru	Br	+49.5	89.8 (5.05)	n.o.	87.9 (4.82)	87.9 (4.82)	
<b>9</b>	Ru	I	+2.7	81.4 (4.56)	83.0 (4.69)	83.0 (4.69)	81.4 (4.56)	78.6 (4.25)
<b>10</b>	Ru	I	n.o.	90.9 (5.12)	n.o.	88.5 (5.03)	88.5 (5.03)	80.4 (4.18)
<b>11</b>	Ru	I	+22.0	84.3 (4.58)	86.6 (4.60)	86.6 (4.60)	84.3 (4.58)	
<b>12</b> <sup>d</sup>	Ru	I	+31.4	90.8 (5.08)	n.o.	90.5 (4.98)	90.5 (4.98)	
			+31.4	86.3 (4.58)	86.0 (4.55)	86.0 (4.58)	86.3 (4.58)	
<b>13</b>	Ru	I	n.o.	92.8 (4.91)	n.o.	91.4 (4.96)	91.4 (4.96)	
<b>14</b> <sup>d</sup>	Os	Br	+17.3	73.8 (4.49)	74.6 (4.62)	74.6 (4.62)	73.8 (4.49)	73.4 (4.36)
<b>15</b>	Os	Br	+27.0	77.5 (5.10)	n.o.	78.7 (5.01)	78.7 (5.01)	75.4 (4.31)
<b>16</b>	Os	Br	+36.5	75.5 (4.68)	80.5 (4.63)	80.5 (4.63)	75.5 (4.68)	
<b>17</b> <sup>d</sup>	Os	Br	+45.9	78.6 (5.15)	n.o.	81.3 (4.96)	81.3 (4.96)	
			+45.9	79.9 (4.53)	77.9 (4.70)	77.9 (4.70)	79.9 (4.53)	

<sup>a</sup>In  $\text{C}_6\text{D}_6$  ( $\sim 10\%$ ), at 298 K, n.o. = not observed.

<sup>b</sup>In  $\text{CDCl}_3$  ( $\sim 10\%$ ), at 298 K,  $\delta^{13}\text{C}(1) = 73.9$  (toluene- $d_8$ , at 213 K).

<sup>c</sup> $\delta^{13}\text{C}(1) = 74.0$  (toluene- $d_8$ , at 213 K);  $\text{NPr}_2$ :  $\delta^{13}\text{C} = 48.8, 25.7$ ,  $\delta^1\text{H} = 4.25, 1.20$ .

<sup>d</sup>Assignment of  $\delta^{13}\text{C}$  [C(2, 5)] and  $\delta^{13}\text{C}$  [C(3, 4)] can be reversed.

**1** and **2**, respectively, together with selected bond distances and bond angles. These are the first X-ray analyses of 1,1'-di(boryl)ferrocenes. In the case of **1**, it is also the first X-ray structure determination of an organoboron dihalide. In compound **1** the boron atoms of the two dibromoboryl groups are

strong Lewis acidic centres, whereas in **2** the electron deficiency of the boron atoms is at least partially compensated by  $\text{BN}(pp)\pi$  bonding. The molecular geometry of **1** (Fig. 1) shows that the molecule is centrosymmetrical and that the angle  $\beta$  is  $10.2^\circ$ . This angle is smaller than in  $\alpha$ -ferrocenyl

Table 2. Experimental data related to the single crystal X-ray analyses of 1,1'-bis(dibromoboryl)ferrocene (**1**) and 1,1'-bis[bis(diisopropylamino)boryl]ferrocene (**2**)

	1	2
Chemical formula	C <sub>10</sub> H <sub>8</sub> B <sub>2</sub> Br <sub>4</sub> Fe (525.3)	C <sub>34</sub> H <sub>64</sub> B <sub>2</sub> FeN <sub>4</sub> (606.4)
Crystal	Red-brown platelet	Orange, prismatic
Size	0.20 × 0.25 × 0.02 mm <sup>3</sup>	0.18 × 0.18 × 0.20 mm <sup>3</sup>
Crystal system; space group	Triclinic; <i>P</i> $\bar{1}$	Monoclinic; <i>P</i> 2 <sub>1</sub> / <i>n</i>
Unit cell dimensions (pm)	<i>a</i> = 655.2(2), <i>b</i> = 692.0(2) <i>c</i> = 858.1(2); $\alpha$ = 83.21(2), $\beta$ = 83.20(2), $\gamma$ = 66.54(2) $^\circ$	<i>a</i> = 940.1(2), <i>b</i> = 1894.1(2), <i>c</i> = 2040.7(2); $\beta$ = 101.65(3) $^\circ$
<i>V</i> ( $\text{\AA}^3$ )	353.30(17)	3558.7(7)
<i>Z</i>	1	4
Absorption coeff. (mm <sup>-1</sup> )	12.347	0.451
Diffractometer	Siemens P4	
Radiation (pm)	Mo- <i>K</i> $\alpha$ , $\lambda$ = 71.073, graphite monochromator	
Temperature (K)	295	173
2 $\theta$ range	3 $^\circ$ $\leq$ 2 $\theta$ $\leq$ 60 $^\circ$	2 $^\circ$ $\leq$ 2 $\theta$ $\leq$ 50 $^\circ$
Scan type	$\omega$	$\omega$
Scan range ( $\omega$ )	1.20 $^\circ$	1.00 $^\circ$
Measured reflections	2393	8123
Independent/observed reflections	1942/1087 [ <i>F</i> > 3.0 $\sigma$ ( <i>F</i> )]	6184/6184
Refined parameters	79	366
Solution	Direct methods (SHELXTL PLUS)	Patterson and consecutive difference Fourier maps
Weighting scheme		$w^{-1} = \sigma^2(F) + 0.0000 F^2$
<i>R</i> / <i>R</i> <sub>w</sub> value	0.066/0.024	0.077/0.040
Max./min. res. electron density (epm <sup>-3</sup> ) ( $\times 10^{-6}$ )	0.93/−1.23	0.48/−0.52

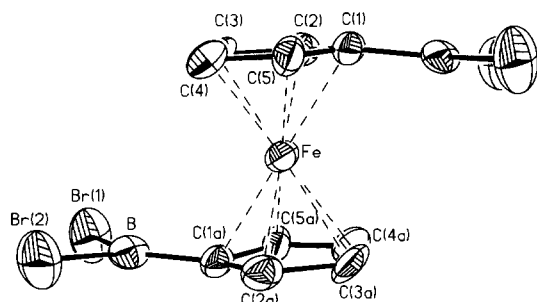

Fig. 1. Molecular structure of 1,1'-bis(dibromoboryl)ferrocene (**1**). Selected bond lengths (pm) and angles ( $^\circ$ ): B—Br(1) 195.4(8), B—C(1a) 145.6(14), B—Br(2) 191.2(8); Br(1)—B—C(1a) 121.0 (5), Br(1)—B—Br(2) 114.6(5), Br(2)—B—C(1a) 124.4(5); B—C(1a)—C(2a)—C(3a) 10.2.

carbocations ( $\beta$  = 14–21 $^\circ$ ; there are no structural data available for  $\alpha,\alpha'$ -ferrocenediyl carbocations), but the tilt of the C(1)—B and C(1')—B bonds towards the iron atom is clearly significant and suggests Fe—B interactions. In contrast, no such tilt is observed in the molecular structure of **2**. In each (Pr<sub>2</sub>N)<sub>2</sub>B group one of the B—N bond

lengths is short [140.8(4), 143.8(4) pm] and one is longer [148.3(5), 145.0(4) pm]. The short B—N distance belongs to the nitrogen atom of the Pr<sub>2</sub>N group which has its NC<sub>2</sub> plane orientated almost parallel to the N<sub>2</sub>BC plane, indicating BN(*pp*) $\pi$  bonding. The Fe—B interaction in **1** must be regarded as weak, since the environment of each boron atom is still exactly trigonal planar as in **2** (within the experimental error).

#### NMR data

The <sup>1</sup>H and <sup>13</sup>C NMR data of **1–17** are in agreement with the proposed structures. The mutual assignment of <sup>1</sup>H and <sup>13</sup>C NMR signals follows from two-dimensional <sup>13</sup>C/<sup>1</sup>H heteronuclear shift correlations (see Fig. 3). In the case of **1**, the assignment of the <sup>13</sup>C resonances has been confirmed by <sup>1</sup>J(<sup>13</sup>C<sup>13</sup>C) data measured from an INADEQUATE experiment (see Fig. 4).

The  $\delta^{11}\text{B}$  data of the ruthenocene and osmocene derivatives **3–17** are particularly instructive when they are compared with those of the corresponding ferrocenes and phenylboron dihalides. There is

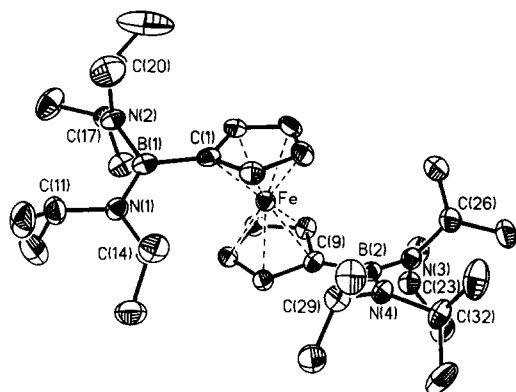

Fig. 2. Molecular structure of bis[bis(diisopropylamino)boryl]ferrocene (**2**). Selected bond lengths (pm) and angles ( $^{\circ}$ ): B(1)—C(1) 158.6(5), B(2)—C(9) 159.3(5), N(1)—B(1) 140.8(4), N(2)—B(1) 148.3(5), N(3)—B(2) 145.0(4), N(4)—B(2) 143.8(4); N(1)—B(1)—C(1) 123.7(3), N(2)—B(1)—C(1) 117.2(3), N(3)—B(2)—N(4) 121.6(3), N(3)—B(2)—C(9) 115.4 (3).

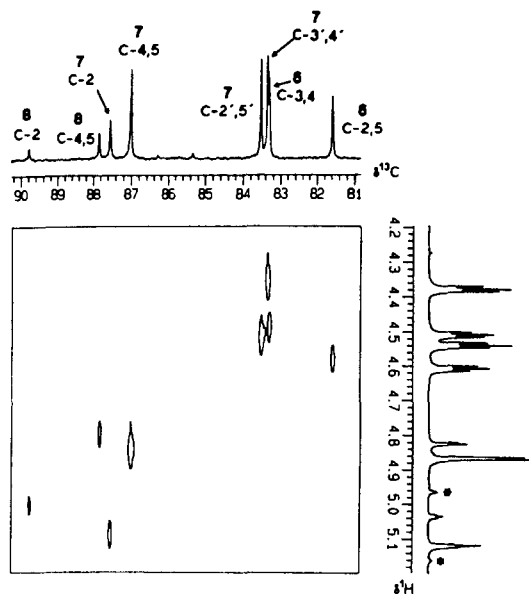

Fig. 3. 67.9 MHz Two-dimensional  $^{13}\text{C}/^1\text{H}$  heteronuclear shift correlation for a mixture of the dibromoboryl-substituted ruthenocenes **6**, **7** and **8** in  $\text{C}_6\text{D}_6$  at  $25^{\circ}\text{C}$ .  $^1\text{H}$  NMR signals in  $F_1$ , marked with asterisks, belong to compound **5**.

already a small difference between the  $\delta^{11}\text{B}$  values of  $\text{PhBCl}_2$  ( $\delta = +54.8^{10}$ ) and ferrocenylboron dichloride ( $\text{Fc-BCl}_2$ ) ( $\delta = +50.5$ ). This difference could in principle result from the linkage of the boron atom either to a six-membered or to a five-membered ring. However, in  $\text{Rc-BCl}_2$  (**3**;  $\delta = +44.4$ ), the  $^{11}\text{B}$  nuclear shielding is further increased as compared with  $\text{Fc-BCl}_2$ . This trend for  $\delta^{11}\text{B}$  values is confirmed and becomes even more pronounced for the complete series of  $\text{PhBBR}_2$

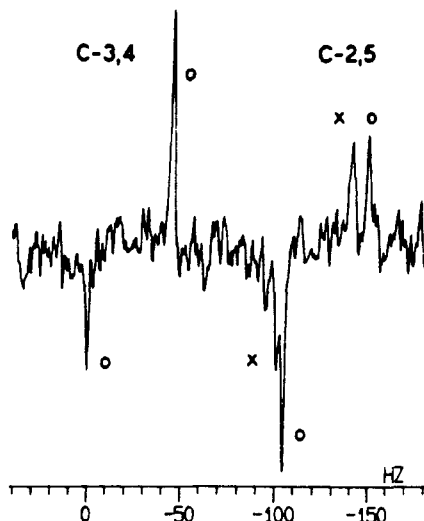

Fig. 4. 67.9 MHz INADEQUATE  $^{13}\text{C}$  NMR spectrum of 1,1'-bis(dibromoboryl)ferrocene (**1**) in  $\text{CDCl}_3$  at  $25^{\circ}\text{C}$ . [ $x: {}^1J(^{13}\text{C}(2), {}^{13}\text{C}(1)) = 39.2$  Hz,  $o: {}^1J(^{13}\text{C}(2), {}^{13}\text{C}(3)) = 45.5$  Hz].

( $\delta = +57.7^{10}$ ),  $\text{Fc-BBR}_2$  ( $\delta = +46.7$ ),  $\text{Rc-BBR}_2$  (**4**;  $\delta = +34.5$ ),  $\text{Oc-BBR}_2$  (**14**;  $\delta = +17.3$ ). In the series of boron diiodides,  $\text{PhBI}_2$  ( $\delta = +48.2^{10}$ ),  $\text{Fc-BI}_2$  ( $\delta = +27.0$ ) and  $\text{Rc-BI}_2$  (**9**;  $\delta = +2.7$ ), the shielding effect of the metallocenyl fragments is stronger than for the boron dibromides. It appears that  $\text{M-B}$  bonding becomes stronger with increasing Lewis acidic strength of the boryl group, leading on average to an increase in the boron coordination number. Thus, the observed increase in  $^{11}\text{B}$  nuclear shielding is similar to the trend for  $\delta^{13}\text{C}(\text{C}^{\alpha})$  values.<sup>1,2</sup>

With an increasing number of  $\text{BX}_2$  substituents at the metallocene, the increase in  $^{11}\text{B}$  nuclear shielding is less pronounced, which is expected if more than one Lewis acidic centre competes for  $\text{M-B}$  interactions. The trend of the  $\delta^{11}\text{B}$  values for the complete series of 1,1'-bis(dibromoboryl)metallocenes [ $\text{M} = \text{Fe}$  (**1**;  $\delta = +50.0$ ),  $\text{Ru}$  (**6**;  $\delta = +44.3$ ) and  $\text{Os}$  (**16**;  $\delta = +36.5$ )] corresponds to that lined out for the mono(boryl)metallocenes. If there are three or four  $\text{BBR}_2$  substituents, the effects again become smaller, but the trend is still the same [ $\text{M} = \text{Fe}$  ( $\delta = +53.0$ ),  $\text{Ru}$  (**7**, **8**;  $\delta = +49.5$ ) and  $\text{Os}$  (**17**;  $\delta = +45.9$ )].

## CONCLUSIONS

$\text{Fe-B}$  bonding interactions, analogous to  $\text{Fe-C}^{\alpha}$  bonding in  $\alpha$ -ferrocenyl carbocations, require strong Lewis acidic boryl groups such as in 1,1'-bis(dibromoboryl)ferrocene (**1**), in contrast to the situation in 1,1'-bis[bis(diisopropylamino)-

boryl]ferrocene (**2**), as shown by the X-ray structure determinations of **1** and **2**. Such M—B bonding (M = Fe, Ru, Os) is also evident from the analysis of the  $\delta^{11}\text{B}$  values of dihalogenoboryl-substituted metallocenes. The relative increase in  $^{11}\text{B}$  nuclear shielding from M = Fe to Os and from X = Cl to I indicates both the function of the metal and of the Lewis acidic character of the boryl group.

## EXPERIMENTAL

All compounds were prepared and handled in an inert atmosphere ( $\text{N}_2$  or argon) by using carefully dried glassware and solvents. Ferrocene, osmocene, the boron halides and di(isopropyl)amine were commercial products. 1,1'-Bis(dibromoboryl)ferrocene (**1**),<sup>8</sup> ruthenocene,<sup>11</sup> 1,1'-dilithioferrocene<sup>9</sup> and bis(diisopropylamino)chloroborane<sup>12</sup> were prepared according to literature procedures.

NMR spectra were measured by using Jeol FX 90Q, Bruker ARX 250 ( $^1\text{H}$ ,  $^{11}\text{B}$ ,  $^{13}\text{C}$  NMR) and Jeol EX 270 ( $^1\text{H}$ ,  $^{13}\text{C}$  NMR) spectrometers. Chemical shifts are given with respect to  $\text{Me}_4\text{Si}$  [ $\delta^1\text{H}(\text{C}_6\text{D}_5\text{H}) = 7.15$ ;  $\delta^{13}\text{C}(\text{C}_6\text{D}_6) = 128.0$ ] and external  $\text{Et}_2\text{O}-\text{BF}_3$  [ $\delta^{11}\text{B} = 0$ ;  $\Xi(^{11}\text{B}) = 32.083972$  MHz].

### 1,1'-Bis[bis(diisopropylamino)boryl]ferrocene (**2**)

A solution of bis(diisopropylamino)chloroborane (2.00 g, 8.12 mmol) in 10  $\text{cm}^3$  of hexane was slowly added to a suspension of 1,1'-dilithioferrocene (0.80 g, 404  $\mu\text{mol}$ ) in 20  $\text{cm}^3$  of hexane at  $-78^\circ\text{C}$ . After warming to room temperature, insoluble material was filtered off. At  $-20^\circ\text{C}$  compound **2** crystallized from hexane (1.70 g, 67.7%) as a red crystalline solid (m.p.  $119\text{--}120^\circ\text{C}$ ).

### Reaction of ruthenocene with $\text{BCl}_3$ (**3**)

A high pressure Schlenk tube was filled with a solution of 0.20 g of ruthenocene (0.86 mmol) in 10  $\text{cm}^3$  of hexane followed by condensing of 0.30  $\text{cm}^3$  of  $\text{BCl}_3$  (3.66 mmol). After heating to  $110^\circ\text{C}$  for 0.5 h, cooling to room temperature and removing all volatile material, the residue was analysed by  $^1\text{H}$  NMR to contain a mixture of 60% dichloroborylruthenocene (**3**) and 40% ruthenocene.

### Reaction of ruthenocene with $\text{BBr}_3$ (**4-8**)

Boron tribromide (2.40 g, 9.58 mmol) was added to a solution of 1.00 g of ruthenocene (4.33 mmol) in 20  $\text{cm}^3$  of hexane. After heating to reflux for 2 h, a mixture was formed consisting (according to NMR spectra) of dibromoborylruthenocene (**4**; 11%),

1,3-bis(dibromoboryl)ruthenocene (**5**; 3%) and 1,1'-bis(dibromoboryl)ruthenocene (**6**; 86%). Further addition of  $\text{BBr}_3$  (3.00 g, 11.98 mmol) and heating to reflux in hexane for 12 h affords a mixture of **5** (3%), **6** (4%), 1,3,1'-tris(dibromoboryl)ruthenocene (**7**; 78%) and 1,3,1',3'-tetrakis(dibromoboryl)ruthenocene (**8**; 15%).

### Reaction of ruthenocene with $\text{BI}_3$ (**9-13**)

After addition of 0.50 g of  $\text{BI}_3$  (1.28 mmol) to a solution of 0.20 g of ruthenocene (0.87 mmol) in 20  $\text{cm}^3$  of hexane, the mixture was heated to reflux for 2 h. The analysis ( $^1\text{H}$ ,  $^{11}\text{B}$  NMR) of the resulting mixture shows the presence of diiodoborylruthenocene (**9**; 56%) and 1,1'-bis(diiodoboryl)ruthenocene (**11**; 44%). Further addition of 0.50 g of  $\text{BI}_3$  (1.28 mmol) and heating to reflux for another 2 h led to a mixture of **9** (10%), 1,3-bis(diiodoboryl)ruthenocene (**10**; 5%), **11** (84%) and less than 1% of 1,3,1'-tris(diiodoboryl)ruthenocene (**12**). A final addition of 1.40 g of  $\text{BI}_3$  (3.58 mmol) and heating to reflux for 12 h produced a mixture of **10** (4%), **11** (69%), **12** (24%) and 1,3,1',3'-tetrakis(diiodoboryl)ruthenocene (**13**; 3%).

### Reaction of osmocene with $\text{BBr}_3$ (**14-17**)

When a solution of 0.20 g osmocene (0.63 mmol) in 10  $\text{cm}^3$  of hexane was treated with 0.25 g of  $\text{BBr}_3$  (1.00 mmol), an insoluble white precipitate was formed at once. After 4 h of heating to reflux, the solution was analysed to contain a mixture of dibromoborylosmocene (**14**; 4%), 1,3-bis(dibromoboryl)osmocene (**15**; 4%), 1,1'-bis(dibromoboryl)osmocene (**16**; 83%) and 1,3,1'-tris(dibromoboryl)osmocene (**17**; 9%).

*Acknowledgements*—Support of this work by the Deutsche Forschungsgemeinschaft and the Fonds der Chemischen Industrie is gratefully acknowledged.

## REFERENCES

- (a) W. E. Watts, *J. Organomet. Chem. Libr.* 1979, **7**, 399; (b) S. Lupan, M. Kapon, M. Cais and F. H. Herbststein, *Angew. Chem.* 1972, **84**, 1104; *Angew. Chem., Int. Edn Engl.* 1972, **11**, 1025; (c) R. L. Sime and B. J. Sime, *J. Am. Chem. Soc.* 1974, **96**, 892; (d) U. Behrens, *J. Organomet. Chem.* 1979, **182**, 89; (e) L. I. Zakharkin, V. V. Kobak, A. I. Yanovsky and Yu. T. Struchkov, *Tetrahedron* 1982, **38**, 3515.
- (a) A. Z. Kreindlin, P. V. Petrovskii, M. I. Rybinskaya, A. I. Yanovsky and Tu. T. Struchkov, *J. Organomet. Chem.* 1987, **319**, 229; (b) M. I. Ryb-

- inskaya, A. Z. Kreindlin and S. S. Fadeeva, *J. Organomet. Chem.* 1988, **358**, 363; (c) M. I. Rybinskaya, A. Z. Kreindlin, Yu. T. Struchkov and A. I. Yanovsky, *J. Organomet. Chem.* 1989, **359**, 233.
3. (a) H. Nöth and B. Wrackmeyer, *Chem. Ber.* 1974, **107**, 3089; (b) B. F. Spielvogel, W. R. Nutt and R. A. Izydore, *J. Am. Chem. Soc.* 1975, **97**, 1609; (c) B. Wrackmeyer, *Z. Naturfor., Teil B* 1980, **35**, 439.
  4. T. Renk, W. Ruf and W. Siebert, *J. Organomet. Chem.* 1976, **120**, 1.
  5. B. Wrackmeyer, U. Dörfler, W. Milius and M. Herberhold, *Z. Naturfor., Teil B*, in press.
  6. H. Horn, F. Rudolph, R. Ahlrichs and K. Merzweiler, *Z. Naturfor., Teil B* 1992, **47**, 1.
  7. W. Ruf, T. Renk and W. Siebert, *Z. Naturfor., Teil B* 1976, **31**, 1028.
  8. B. Wrackmeyer, U. Dörfler and M. Herberhold, *Z. Naturfor., Teil B* 1993, **48**, 121.
  9. M. D. Rausch and D. J. Ciappenelli, *J. Organomet. Chem.* 1967, **10**, 127.
  10. H. Nöth and B. Wrackmeyer, in *Nuclear Magnetic Resonance of Boron Compounds; NMR—Basic Principles and Progress* (Edited by P. Diehl, E. Fluck and R. Kosfeld). Springer, Berlin (1978).
  11. P. Pertici and G. Vitulli, *J. Chem. Soc., Dalton Trans.* 1980, 1961.
  12. D. W. Aubrey, M. F. Lappert and M. K. Majumdar, *J. Chem. Soc.* 1962, 4088.