

## KINETICS OF THE THERMAL REGENERATION OF SPENT ACTIVATED CARBON IN A FLUIDIZED BED

J.S.J. VAN DEVENTER \* and B.S. CAMBY

*Department of Metallurgical Engineering, University of Stellenbosch, Stellenbosch, 7600 (South Africa)*

(Received 26 January 1988)

### ABSTRACT

Activated carbon loaded with phenol, and spent carbon from a gold adsorption plant, were regenerated in a steam–nitrogen atmosphere in a small batch fluidized bed. Samples were treated at constant temperatures ranging from 300 to 900 °C for different periods of time, after which the loss in mass was determined. A kinetic model was found to yield reasonable predictions of this mass loss. It was assumed that pyrolysis of the adsorbate and active groups proceeded via a first order reaction, and was more pronounced during the initial stages of regeneration. The maximum level of pyrolysis increased with increasing temperature. Gasification of the base carbon and the char residue was assumed to be dependent on the surface area. As this was assumed to remain reasonably constant, the carbon–steam reaction was assumed to be zero order. The activation energy of the pyrolysis reaction was 29.8 and 34.3 kJ mol<sup>-1</sup> for the carbon loaded with phenol and the eluted plant carbon respectively. Corresponding values for the gasification reaction were 77.3 and 76.9 kJ mol<sup>-1</sup>. Silver cyanide was used to determine the equilibrium adsorption capacities of the regenerated samples of carbon. It was found that the temperature rather than the duration of regeneration influenced the activity of the carbon.

### INTRODUCTION

Activated carbon is used widely for removal of organic pollutants from effluents [1,2] and the extraction of gold and silver cyanides from leached slurries [3–6]. Some organics loaded on the carbon are not removed by elution or acid washing, and should be volatilized by thermal regeneration in order to restore the activity of the carbon [3,4]. The economic feasibility of many adsorption processes is affected strongly by the cost of regenerating the spent carbon [7]. Problems experienced with rotary kilns on gold plants have resulted in the development of an electrical-resistance (Rintoul) furnace [3,6]. Fluidized bed furnaces [8,9] are not widely used, but should be

---

\* Author to whom correspondence should be addressed.

more thermally efficient than the popular multi-hearth furnaces. A common problem encountered in practice is that of insufficient heat transfer, which means that regeneration temperatures are too low for effective reactivation.

Regeneration of carbon consists usually of the following steps: (a) drying ( $\leq 200^\circ\text{C}$ ); (b) vaporization of volatile adsorbates ( $200\text{--}500^\circ\text{C}$ ); (c) pyrolysis of non-volatile adsorbates, with the formation of a char residue ( $500\text{--}700^\circ\text{C}$ ); and (d) selective oxidation of this residue, using steam or carbon dioxide ( $\geq 700^\circ\text{C}$ ). A small amount of the original carbon is also oxidized in this way. The atmosphere in a regeneration furnace is depleted in oxygen in order to minimize the aggressive oxidation of pyrolysed residue and base carbon. Suzuki et al. [10], and Camby and van Deventer [11], showed that the amount of residue depends on the nature of the adsorbate. No quantitative relationship exists at present between the adsorptive properties of the carbon and the conditions of regeneration.

Urbanic et al. [5] and Avraamides [4] conducted small scale regeneration tests under realistic conditions in order to determine the effect of temperature, time and steam addition on carbon activity. No detailed explanations were given for the effects observed. Some authors [3,12] measured the pore size distributions for different conditions of regeneration, but did not study the kinetics of pyrolysis or gasification. Most of the fundamental work on regeneration kinetics has been done by means of TGA, and deals with either the pyrolysis or the carbon–steam reaction [2,13–17].

It is the aim here to study the kinetics of regeneration in a small fluidized bed. A simple model will be formulated for the mass loss as a function of time and temperature. These conditions will be related empirically to the equilibrium capacity of the carbon to adsorb silver cyanide.

## KINETIC MODEL

The steam gasification of activated carbon usually follows Langmuir–Hinshelwood kinetics [9,14,17]

$$R_g = \frac{k_1 P_{\text{H}_2\text{O}}}{1 + k_2 P_{\text{H}_2} + k_3 P_{\text{H}_2\text{O}}} \quad (1)$$

If the partial pressures of steam  $P_{\text{H}_2\text{O}}$  and hydrogen  $P_{\text{H}_2}$  remain constant during a run, then the rate  $R_g$  of burn-off per second per kg of virgin carbon existing will be constant. This means that the reaction will be zero order if the mass of carbon remains constant under isothermal conditions. Klei et al. [18] observed that the activated carbon–steam reaction is not very sensitive to variations in the gas flow rate, and that external mass transfer does not control overall reaction dynamics. Furthermore, Chihara et al. [14] showed that intraparticle diffusion is not likely to affect the overall kinetics at the temperatures normally used.

It is assumed here that the total surface area available for gasification remains constant during a run. While the base carbon is partly covered by organic foulants, the pyrolysed residue is also amenable to gasification. All rate constants are assumed to have an Arrhenius dependence on temperature. The mass loss  $M_g$  due to the carbon–steam reaction is thus given by

$$M_g = R_g t = t B_g \exp\left(-\frac{E_g}{R_0 T}\right) \quad (2)$$

Kato et al. [19] also assumed the carbon–steam reaction to be zero order, but did not take the decomposition of adsorbed materials into account. Most authors [13,16,30] have taken the decomposition and pyrolysis reactions as being first order. Here, the kinetics of this reaction step are given by

$$R_d = -\frac{d(q - q_\infty)}{dt} = k_d (q - q_\infty) \quad (3)$$

with  $q = q_0$  at  $t = 0$ , and  $q = q_\infty$  at  $t = \infty$ .

The mass loss  $M_d$  due to decomposition and pyrolysis is then

$$M_d = q_0 - q = \{q_0 - q_\infty\} [1 - \exp(-k_d t)] \quad (4)$$

where

$$k_d = B_d \exp\left(-\frac{E_d}{R_0 T}\right) \quad (5)$$

The fractional mass loss  $\beta$  after infinite time is assumed to be independent of the initial loading  $q_0$  [10,20]

$$\beta = (q_0 - q_\infty)/q_0 \quad (6)$$

Thermal decomposition of the virgin carbon can also take place [13,15,16,20]. In some cases the mass loss due to this reaction is a linear function of temperature [11,15]. Here, the decomposing active groups on the surface in the pores of the carbon [20] are included in the loading  $q$ . Little has been published on the relationship between  $\beta$  and temperature. Furthermore, non-isothermal conditions are normally used to determine  $\beta$ . It is assumed here that, within a limited temperature range,  $\beta$  can be approximated by

$$\beta = \beta^*(T - T_0) \quad (7)$$

The total mass loss  $M$  is

$$M = M_g + M_d \quad (8)$$

so that

$$M = t B_g \exp\left(-\frac{E_g}{R_0 T}\right) + q_0 \beta^*(T - T_0) \left[1 - \exp\left\{-t B_d \exp\left(-\frac{E_d}{R_0 T}\right)\right\}\right] \quad (9)$$

In eqn. (9) the mass loss  $M$  is a function of time and temperature, and is assumed to be independent of gas flow in the fluidized bed. The activation

energies  $E_g$  and  $E_d$ , and the parameters  $A_g$ ,  $A_d$  and  $\beta^*$ , will be estimated from a regression analysis. The data of mass loss at different temperatures and times of regeneration will be used for this purpose. The initial quantity of active groups on the internal surface of the carbon, and the exact loading of foulants on an industrial carbon are difficult to determine a priori. Therefore,  $q_0\beta^*$  will be estimated here as a lumped quantity.

## EXPERIMENTAL PROCEDURE

### *Samples of carbon*

Fresh Le Carbone G210 AS activated carbon with apparent density  $890 \text{ kg m}^{-3}$  was used to adsorb pure phenol to a level of  $110 \text{ mg g}^{-1}$ . When this carbon was subjected to thermogravimetric analysis (TGA) by heating at  $7.6^\circ\text{C min}^{-1}$  up to  $1025^\circ\text{C}$ ,  $30 \text{ mg g}^{-1}$  could be removed. Another carbon was obtained from a gold mine in the Evander area in South Africa. This sample of coconut shell carbon was taken after elution and acid washing, but before the regeneration stage. The adsorbed materials on such industrial carbons are difficult to identify, but usually consist of oils, flotation reagents and other organics in the gold plant solutions. Before use, the size fraction between 1.4 and 1.7 mm was dried to a constant mass for 24 h at  $120^\circ\text{C}$ .

### *Fluidized bed regeneration*

The fluidized bed regenerator and ancillary equipment are shown in Fig. 1. One advantage of using this furnace instead of a normal TGA balance is that a larger sample (30 g) can be treated, which allows a series of equilibrium adsorption tests to be performed on one sample. The reactor

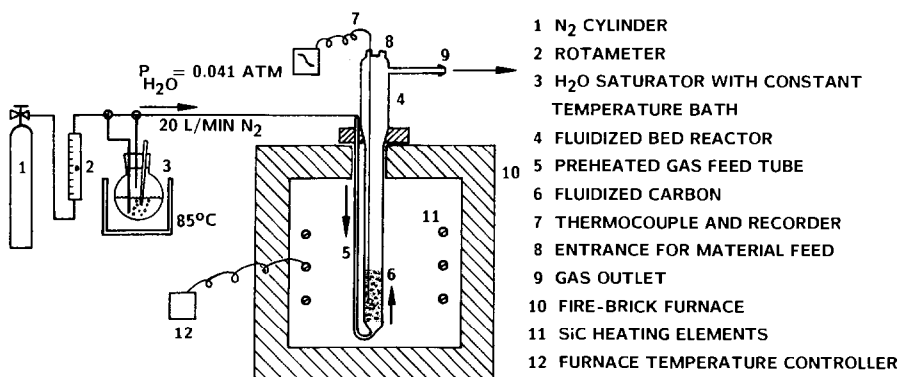

Fig. 1. Fluidized bed reactor and ancillary equipment.

was made of vitreous silica, and had a length of 0.55 m and an internal diameter of 0.030 m. A perforated plate with eight holes of diameter 1.5 mm supported the fluidized bed.

When 30 g carbon was fluidized by nitrogen gas at a flow rate of 25 l  $\text{min}^{-1}$  at 800 °C, the bed height increased from 7.5 cm to 11 cm. The gas was bubbled through distilled water at 85 °C to increase  $P_{\text{H}_2\text{O}}$  to 0.041 atm, and was pre-heated before entering the reactor. A Pt (6% Rh)/Pt(30% Rh) thermocouple was used to monitor the temperature, which took 2 min to stabilize.

### *TGA of carbon*

Regenerated samples (1.3 g) of the gold plant carbon were heated at 7.6 °C  $\text{min}^{-1}$  to 1025 °C in a Stanton Redcroft Massflow thermobalance, using an atmosphere of purified argon. This was done in order to determine the amount of removable material left on the carbon.

### *Adsorption of silver cyanide*

Gold and silver cyanides behave similarly during adsorption on activated carbon [21], so that conclusions drawn from work on  $\text{KAg}(\text{CN})_2$  will also be applicable to the industrially more important  $\text{KAu}(\text{CN})_2$ . The equilibrium adsorption capacity of the regenerated carbon was determined by contacting 1.5 g carbon with 1.0 l solution having different initial concentrations of  $\text{KAg}(\text{CN})_2$ . Equilibrium conditions were attained after 5 weeks. While oxygen has an important influence on the adsorption of metal cyanides on carbon [22], these tests were done in open agitated containers.

## RESULTS AND DISCUSSION

Figure 2 shows the mass loss per initial mass of the virgin carbon, while Fig. 3 gives the mass loss per initial mass of the eluted carbon during regeneration in the fluidized bed. The solid lines are the model predictions. In both cases the model predicts experimental data reasonably well at different constant temperatures. The parameters estimated from the experimental data, and used consequently in the predictions, are stated in Table 1. These parameters were not applicable to temperatures below 500 °C. The activation energies for both types of reactions were significantly lower than those determined by other authors [2,13–17]. However, the  $E_a = 29.8 \text{ kJ mol}^{-1}$  for the carbon loaded with phenol was similar to that measured for the same carbon during TGA [20].

It appears as though the mass loss increased linearly with time after about 10 min, which suggests that the zero order gasification reaction became rate

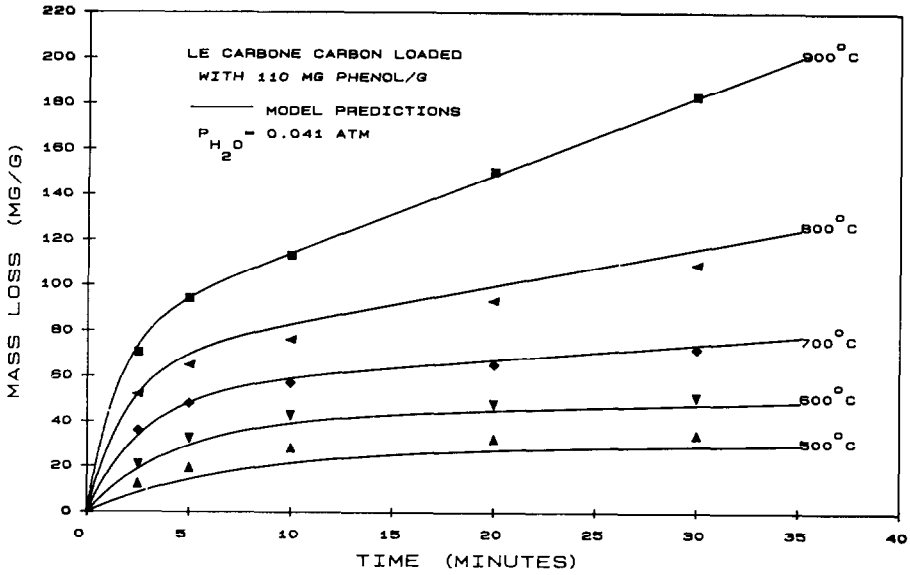

Fig. 2. Regeneration kinetics of fresh Le Carbone carbon loaded initially with 110 mg phenol  $g^{-1}$ .

controlling after the initial decomposition and pyrolysis had ceased. Kato et al. [19] assumed that the latter reactions were completed within a few minutes. They also observed that the rate of mass loss of residue after pyrolysis was almost equal to the rate of mass loss of the virgin carbon itself.

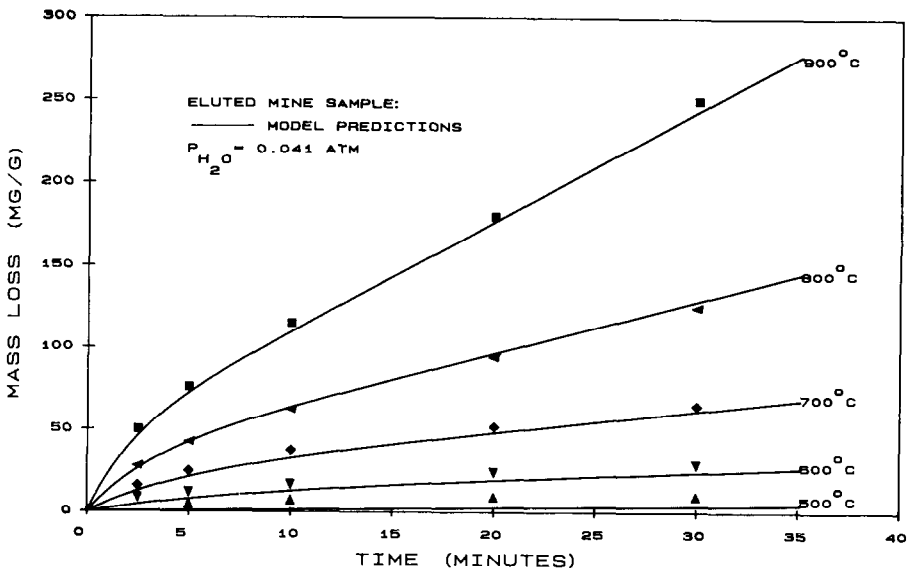

Fig. 3. Regeneration kinetics of eluted carbon from a gold plant.

TABLE 1

Parameters used in model predictions

Kinetic parameter	Le Carbone carbon (110 mg phenol g <sup>-1</sup> )	Eluted gold plant carbon
$B_g$ (mg g <sup>-1</sup> min <sup>-1</sup> )	9500	17727
$B_d$ (min <sup>-1</sup> )	14.4	15.2
$q_0\beta^*$ (mg g <sup>-1</sup> K <sup>-1</sup> )	0.13	0.107
$T^0$ (K)	560	766
$E_g$ (kJ mol <sup>-1</sup> )	77.3	76.9
$E_d$ (kJ mol <sup>-1</sup> )	29.8	34.3

This supports the assumption made here that eqn. (2) describes the gasification of base carbon and char residue.

Figure 4 illustrates the mass removable by TGA of the regenerated eluted plant carbon. As would be expected, the mass decreased with an increase in the temperature of regeneration. Significant removal of foulants took place only at temperatures higher than 500°C, where the carbon-steam reaction was important [2,17]. Umehara et al. [17] also demonstrated that steam regeneration was required before the adsorptive capacity could be restored. It is clear that an increase in the time of regeneration beyond 10 min did not remove more adsorbate.

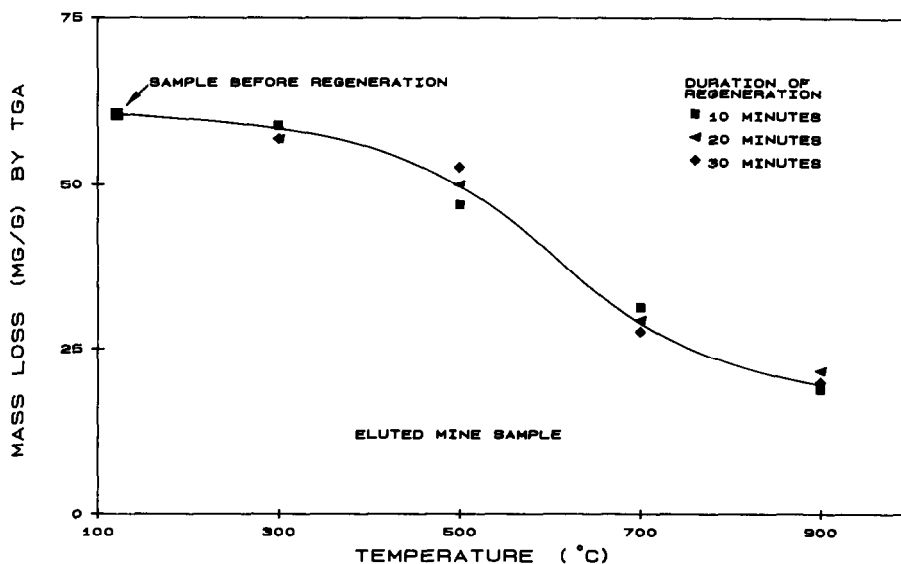

Fig. 4. Residual mass removable from regenerated gold plant carbon by TGA at 7.6°C min<sup>-1</sup> up to 1025°C.

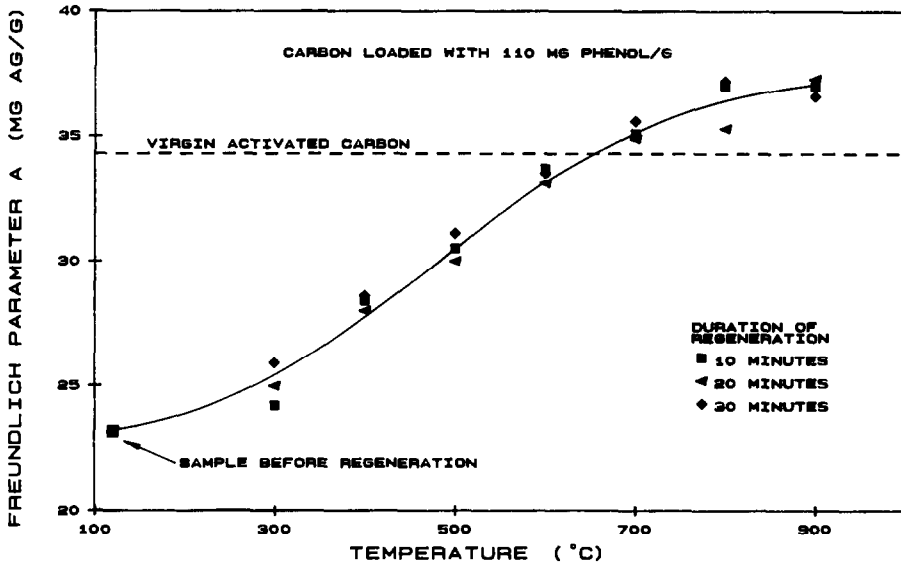

Fig. 5. Influence of regeneration conditions on the equilibrium adsorptive capacity of Le Carbone carbon loaded initially with 110 mg phenol  $\text{g}^{-1}$ .

A Freundlich relationship can be used to correlate data for the equilibrium adsorption of silver cyanide on activated carbon

$$q_e = AC_e^n \quad (10)$$

When eqn. (10) was fitted to the adsorption isotherms for samples regenerated at different temperatures, Camby [21] observed that the values of  $n$  did not vary much. Therefore, a constant  $n = 0.18$  was used here when fitting eqn. (10) to data for the equilibrium adsorption of silver cyanide on the two types of carbon. The parameter  $A$  then represents the equilibrium adsorption capacity of the carbons. It is argued that this approach is of more practical use than merely the determination of surface area [13,14] or the iodine number [19].

The Freundlich  $A$  values for the two carbons regenerated under different conditions are shown in Figures 5 and 6. As expected, the adsorption capacity increased significantly with an increase in temperature in both cases. Figure 5 illustrates that the adsorption capacity could be restored completely, and even improved, at temperatures of 800°C or 900°C. In contrast to these results, van Vliet and Venter [12] found that it was impossible to effectively regenerate carbon at 900°C or 950°C. Excessive meso- and macropore enlargement occurred, and the extent of micropore restoration was greatly diminished [12].

The observation that the duration of regeneration had no influence on the adsorption capacity is supported by the results of Fig. 4, as well as those of Umehara et al. [17]. Chiara et al. [9] observed an optimal duration, beyond



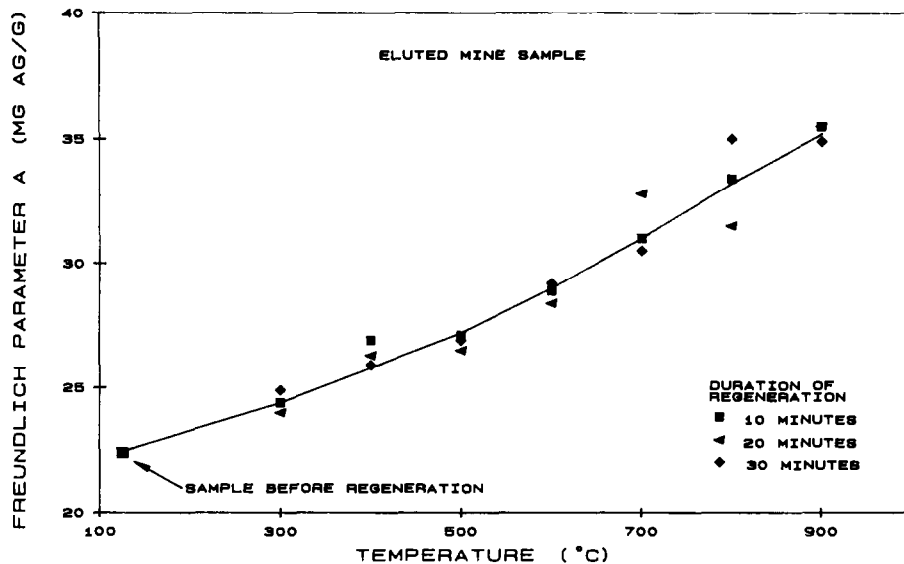

Fig. 6. Influence of regeneration conditions on the equilibrium adsorptive capacity of gold plant carbon.

which the surface area and the adsorption capacity both decreased. Kato et al. [19] stated that the relative adsorptive capacity was determined only by the mass loss, regardless of the carbon, adsorbate or temperature.

## CONCLUSIONS

(1) The kinetic model proposed here for the simultaneous pyrolysis and gasification reactions during regeneration fitted the experimental data satisfactorily.

(2) Pyrolysis and decomposition of the foulants took place mainly during the initial stages of a run, after which the carbon–steam reaction was found to be controlling.

(3) An increase in the temperature, rather than the duration of regeneration in the fluidized bed enhanced the adsorptive capacity of a carbon.

(4) It was possible at high temperatures to increase the adsorptive capacity of a carbon above that of the unloaded virgin carbon.

## LIST OF SYMBOLS

- A* coefficient in Freundlich isotherm  
*B* pre-exponential factor in Arrhenius equation  
*C* concentration of silver in liquid phase (mg Ag l<sup>-1</sup> in eqn. (10))

$\beta$	fractional mass loss at infinite time due to decomposition and pyrolysis
$\beta^*$	temperature coefficient in eqn. (7)
$E$	activation energy
$k$	rate constant
$M$	mass loss per unit mass of initial virgin or loaded carbon
$n$	exponent in Freundlich isotherm
$P$	partial pressure
$q$	mass of adsorbed material per unit mass of initial virgin carbon or loaded carbon (mg Ag g <sup>-1</sup> in eqn. (10))
$q_\infty$	value of $q$ after infinite time
$R_0$	universal gas constant
$R$	specific mass loss $M$ per unit time
$t$	time
$T$	absolute temperature
$T_0$	temperature at which decomposition and pyrolysis begin (eqn. (7))

### Subscripts

d	decomposition and pyrolysis reactions
e	equilibrium conditions
g	carbon–steam gasification reaction
0	initial
1–3	terms in the Langmuir–Hinshelwood expression eqn. (1)

### ACKNOWLEDGEMENTS

The financial and technical assistance received from the General Mining-Union Corporation is gratefully acknowledged. Thanks are extended to Mr. E.P. Marais for technical assistance.

### REFERENCES

- 1 B.M. van Vliet, *Prog. Water Technol.*, 10 (1978) 555.
- 2 K. Hashimoto, K. Miura and T. Watanabe, *AIChE J.*, 28 (1982) 737.
- 3 P.A. Laxen and T.D. Brown, in L.F. Haughton (Ed.), *Proc. Mintek50: Int. Conf. on Mineral Science and Technology*, Randburg, The Council for Mineral Technology, 1984.
- 4 J. Avraamides, *Inst. Min. Metall., Trans., Sect. C*, 96 (1987) C137.
- 5 J.E. Urbanic, R.J. Jula and W.D. Faulkner, *Miner. Metall. Process.*, 2 (1985) 193.
- 6 P.M. Cole, D.S. van Broemsen and P.A. Laxen, in C.E. Fivaz and R.P. King (Eds.), *Gold 100: Proc. Int. Conf. on Gold, Vol. 2, Extractive Metallurgy of Gold*, S. Afr. Inst. Min. Metall., Johannesburg, 1986.
- 7 P.K.T. Liu and N.J. Wagner, *Environ. Prog.*, 4 (1985) 136.
- 8 L.A. Hernandez and P. Harriott, *Environ. Sci. Technol.*, 10 (1976) 454.

- 9 K. Chihara, M. Suzuki and J.M. Smith, *AIChE J.*, 28 (1982) 129.
- 10 M. Suzuki, D.M. Mistic, O. Koyama and K. Kawazoe, *Chem. Eng. Sci.*, 33 (1978) 271.
- 11 B.S. Camby and J.S.J. van Deventer, *Thermochim. Acta*, 113 (1987) 341.
- 12 B.M. van Vliet and L. Venter, *Water Sci. Technol.*, 17 (1984) 1029.
- 13 K. Chihara, J.M. Smith and M. Suzuki, *AIChE J.*, 27 (1981) 213.
- 14 K. Chihara, I. Matsui and J.M. Smith, *AIChE J.*, 27 (1981) 220.
- 15 K. Urano, E. Yamamoto and H. Takeda, *Ind. Eng. Chem. Proc. Des. Dev.*, 21 (1982) 180.
- 16 T. Umehara, P. Harriott and J.M. Smith, *AIChE J.*, 29 (1983) 732.
- 17 T. Umehara, P. Harriott and J.M. Smith, *AIChE J.*, 29 (1983) 737.
- 18 H.E. Klei, J. Sahagian and D.W. Sundstrom, *Ind. Eng. Chem. Proc. Des. Dev.*, 14 (1975) 470.
- 19 K. Kato, K. Matsuura, Y. Sawamura, H. Mori and T. Hanzawa, *J. Chem. Eng. Jpn.*, 13 (1980) 214.
- 20 J.S.J. van Deventer and B.S. Camby, *Thermochim. Acta*, 104 (1986) 61.
- 21 B.S. Camby, M. Ing. Thesis, University of Stellenbosch, South Africa, 1985.
- 22 P.F. van der Merwe and J.S.J. van Deventer, *Chem. Eng. Commun.*, 65 (1988) 121.