

AUTOMATED THERMAL CONDUCTIVITY APPARATUS *

R.T. LAMOUREUX

McDonnell Douglas Astronautics Company, Huntington Beach, California 92647 (U.S.A.)

(Received 9 February 1979)

ABSTRACT

The importance of reducing the time required for taking thermal conductivity measurements has increased due to the need to conserve energy. A method is described that reduces man-hours to a minimum while getting the maximum information from the measurements.

The equipment uses a microprocessor to automatically scan the temperature, a data logger to make the required temperature measurements, and a computer to plot the results of the thermal conductivity values obtained. Early experiments produced values accurate to within 5%. With further refinements this can be improved to 1%.

Already, the effect of curing thermosetting materials has been seen in measurements. Future applications can include tailoring materials to provide specific thermal conductivity properties and make it possible for some of the differences between a priori calculations and experiments to be better understood.

INTRODUCTION

There is currently a great emphasis on energy generation, storage, and conservation. Daily, new materials are being sought for their insulating qualities and we must be able to quantify the insulating capabilities of materials developed.

The traditional parameter for insulation evaluation is the thermal conductivity, K . It is measured at temperature equilibrium by periodic temperature measurements across a sample through which a known heat flux is passing. When measurements at several successive time intervals are the same, it is possible to calculate K . A more popular method is to sandwich a test sample between two materials of known K , heat the entire stack to equilibrium, and calculate the sample conductivity using the assumption of one-dimensional heat flow.

These systems require long periods of time for the sample to establish equilibrium at each desired temperature; or alternatively, considerable operator skill and attention to approach the desired temperature in the

* Presented at the 8th North American Thermal Analysis Society Conference, Atlanta, Georgia, October 16–18, 1978.

proper manner to minimize overshoot and cycling of the furnace. This paper discusses a system that has been developed to turn the tedious process over to a microcomputer requiring only minimal operator attention.

STEADY-STATE DETERMINATION

To justify the "quasi" equilibrium approach to thermal conductivity, we first review the steady-state approach. The temperature drop across a sample, ΔT , is related to the heat flux, q/A , by the relation

$$K \frac{\Delta T}{\Delta x} = \frac{q}{A} \quad (1)$$

where Δx is the thickness of the sample and K is its thermal conductivity. In the comparison method of thermal conductivity measurement, a reference material of known conductivity and of the same area as the sample is placed on either side of the sample (Fig. 1). Since the heat flux is the same for each material, the equality

$$K \left(\frac{\Delta T}{\Delta x} \right)_{TR} = K \left(\frac{\Delta T}{\Delta x} \right)_{BR} = K \left(\frac{\Delta T}{\Delta x} \right)_s \quad (2)$$

holds. There is usually a temperature drop of about 30–40 degrees across

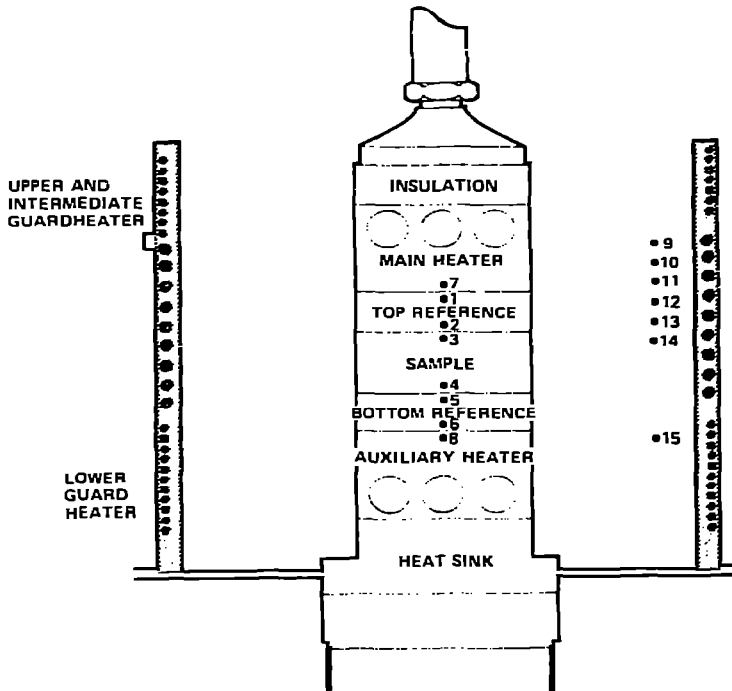

Fig. 1. Thermal conductivity measurement apparatus.

the stack, so it is customary to calculate the sample conductivity from the average of the two known materials, or

$$K_s = \left(\frac{\Delta x}{\Delta T}\right)_s \left(\frac{1}{2}\right) \left[\left(K \frac{\Delta T}{\Delta x}\right)_{TR} + \left(K \frac{\Delta T}{\Delta x}\right)_{BR} \right] \quad (3)$$

Experience has shown that this method requires at least 1 h for each 50-degree change in temperature before equilibrium is established. To minimize the time required to establish equilibrium, make a measurement, and begin heating to the next temperature, we must examine the accuracy of the calculation from eqn. (3).

ACCURACY

Typically, the thermocouples are mounted in grooves in the specimen, producing an error in Δx of 0.010 in. per piece. For a 3/8 in. sample, this represents a 2% indeterminacy for K . When chromel—alumel thermocouples randomly pulled from a spool are used, the relative temperature difference, ΔT , could be in error to 0.1 degree, or less than 0.1% in the temperature range normally used.

With an overall goal of 3% accuracy, we can allow the non-equilibrium temperatures to introduce 1% error, the rest being taken up in the sample preparation. It is permissible, therefore, to allow, conservatively, a 1.0-degree of deviation from equilibrium to exist across the sample—reference stack.

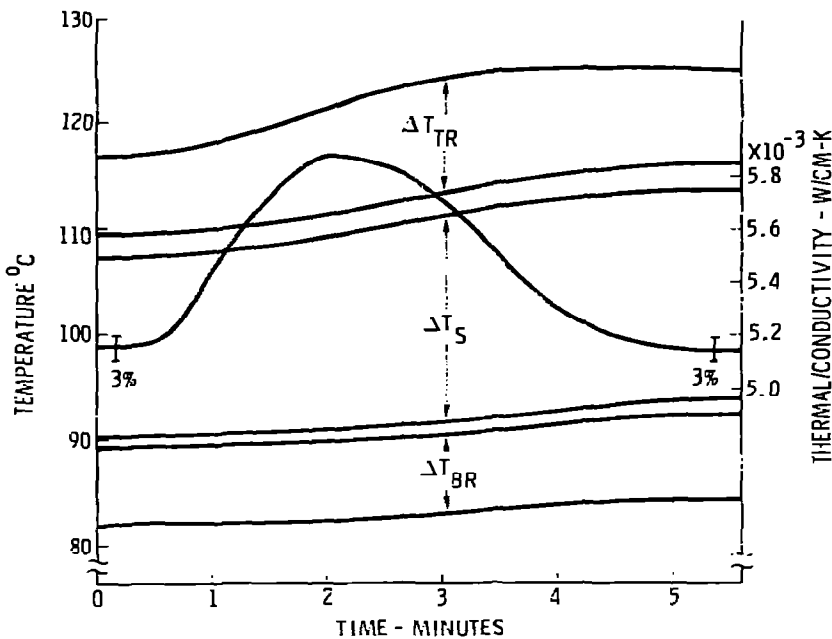

Fig. 2. Thermal history during temperature transition.

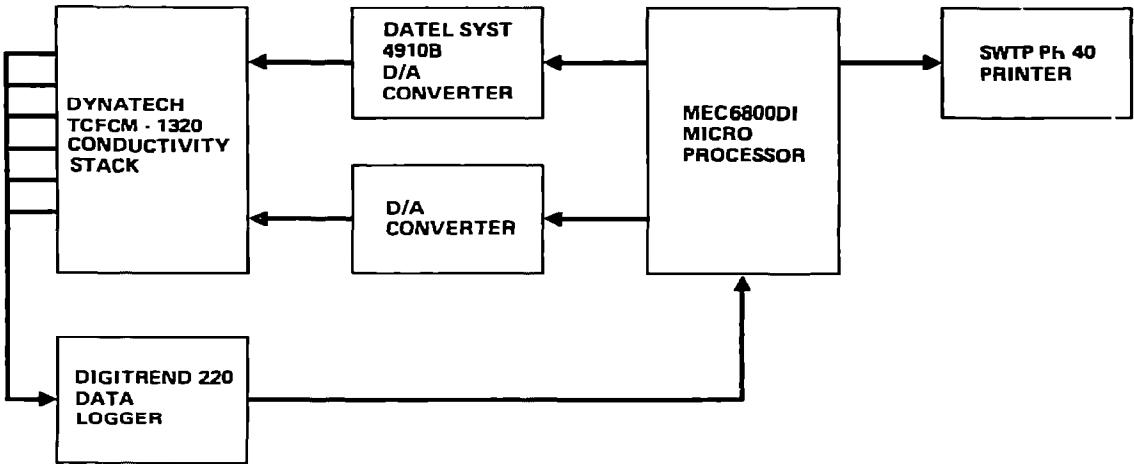

Fig. 3. Block diagram of automated thermal conductivity apparatus.

The time required to establish a stable temperature depends on the size of the temperature step output by the computer and the thermal response of the sample. A typical temperature trace for a five degree step is shown in Fig. 2.

Figure 3 shows a block diagram of the automated thermal conductivity system. The data logger reads the temperatures in the stack, converts them into binary temperature data for the microprocessor, and prints the temperatures. The microprocessor compares the temperature readings with the previous measurement to determine when the change is small enough for the system to be essentially at equilibrium. After equilibrium is established, the microprocessor calculates the thermal conductivity, sends it to the printer, and increments the temperature one digit. This process is repeated until the maximum temperature desired is reached. When the last temperature point is read, the microprocessor returns the controllers to a set point below room temperature and signals that the run is complete.

The logic used in the microprocessor is shown in Fig. 4. The data logger converts the millivolt output of the thermocouples into temperature to the nearest tenth of a degree and delivers a binary data stream to the microprocessor. When this is completed, the microprocessor tests the incoming data. At a stationary temperature, it does its calculations, using a polynomial fit of the standard conductivity to temperature, and prints the result on the printer. The digital-to-analog converters are then incremented one digit, and the waiting and testing sequence is repeated. The digital-to-analog converter being used presently uses the one eight-bit word from the microprocessor. This allows the temperature span to be broken up into 256 increments. For the range from 0 to 400°C, each increment is 1.6 degrees.

At the present time, our system is not complete because of the usual interfacing problems. This is accommodated for by technician taking the data logger printout and putting the temperatures into a computer for the calcula-

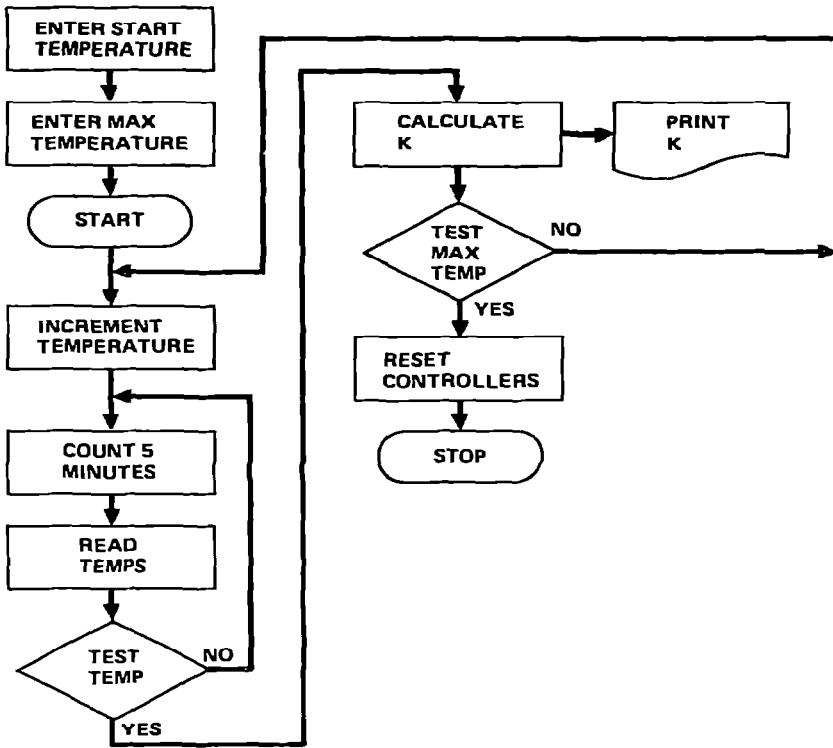

Fig. 4. Flow chart of automatic control system.

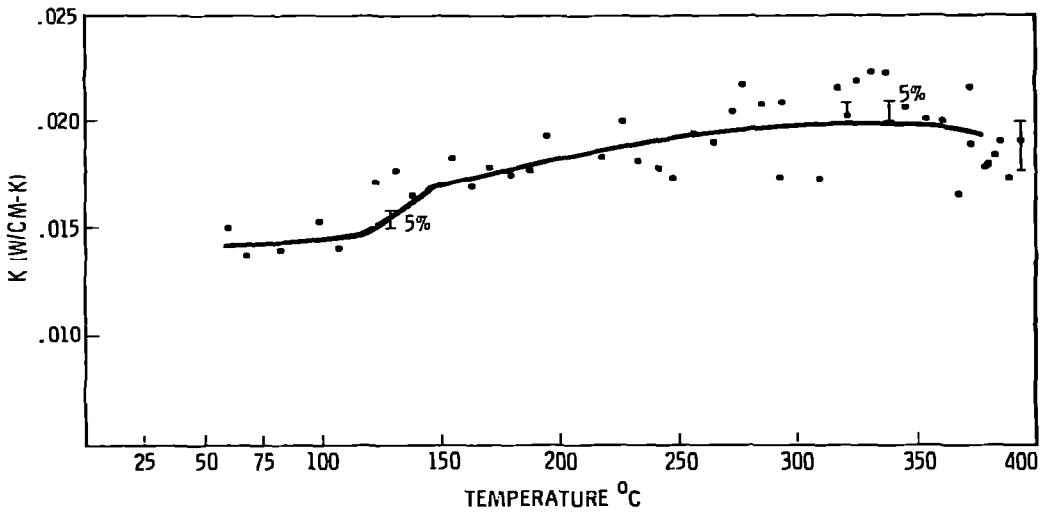

Fig. 5. First automated thermal conductivity run.

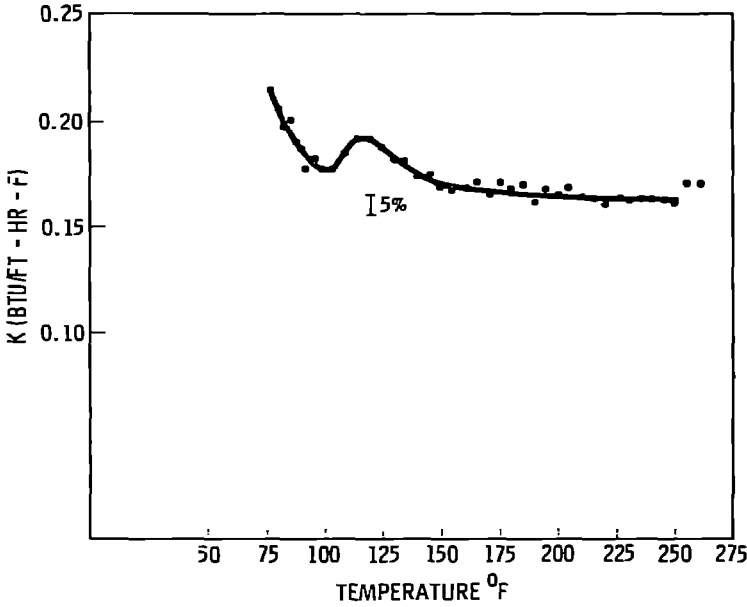

Fig. 6. Automated thermal conductivity run with improved timing.

tions. Because the system is not a closed-loop one, the temperature is measured and incremented at 5- or 10-min intervals automatically, depending on the sample conductivity.

Figure 5 is the first run showing the scatter produced when the microprocessor was not synchronized with the data logger. Even with this scatter, it was possible to note a definite step in the conductivity as the material went through the original cure temperature.

The results of proper timing of the data logger and microprocessor are seen in Fig. 6. Below 90 $^{\circ}$ F, the guard system was not at equilibrium with the stack attributing to the high conductivity. The material in this case was cast at room temperature and had residual solvent in it. As the solvent evaporated, it increased heat loss, giving apparent conductivity increase.