

Note

A CONVENIENT ELECTRICAL CONDUCTIVITY (EC)—DIFFERENTIAL THERMAL ANALYSIS (DTA) APPARATUS

W.W. WENDLANDT

Thermal Analysis Laboratory, Department of Chemistry, University of Houston, Houston, Texas 77004 (U.S.A.)

(Received 1 September 1979)

Several electrical conductivity (EC) instruments have been constructed in this laboratory during the past 10 years. The first EC apparatus [1] consisted of a probe, containing two electrodes, which was inserted into the powdered sample. By means of this arrangement, the quadruple points of a number of metal salt hydrates were determined. Later, a high pressure version of this apparatus, capable of use up to 170 atm applied pressure, was described [2].

Using a pressed-disk sample, three EC instruments were described. One apparatus could be used up to a maximum temperature limit of 500°C [3] while the other could be used up to 1000°C [4]. Not only could these instruments be employed for EC measurements to higher temperatures, but they also used an a.c. (100 Hz) rather than d.c. applied potential to prevent polarization effects. Concurrent and simultaneous thermal analysis measurements, one parameter of which was EC, were also described. A simultaneous EC—DTA apparatus was described in 1973 [5] and a concurrent instrument for EC—DTA and/or EC—TG measurements was described in 1978 [6]. The latter apparatus employed a commercially available thermal analysis system (DuPont Model 900).

The apparatus described here can be used for concurrent EC—DTA measurements on pressed sample disks up to a maximum temperature of about 1000°C. A new arrangement for the temperature detection of the EC sample is also discussed.

EXPERIMENTAL

EC—DTA apparatus

A schematic diagram of the probes and furnace arrangement is illustrated in Fig. 1. The EC probe (A) was similar to that previously described [6] except that the sample temperature was detected by a thermocouple welded to an external nickel plate. The pressed sample disk was held by a spring loaded holder between a Pt and a Au electrode. The DTA probe (B) consisted of a 10 mm × 16 mm Ni plate (0.005 in thickness) to which was welded two

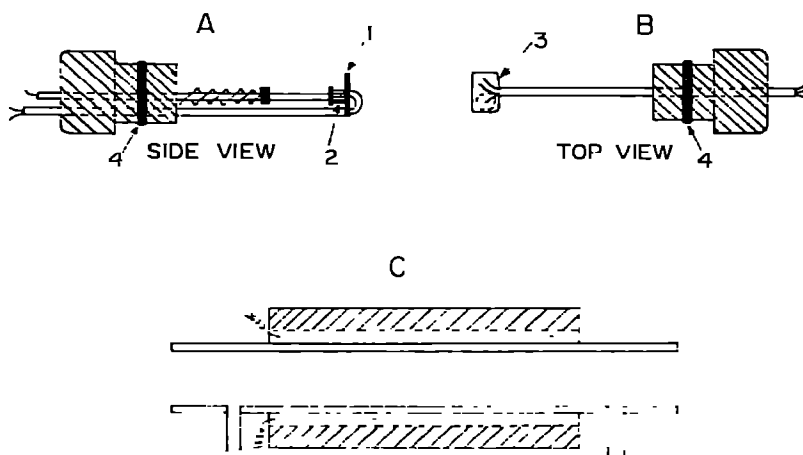

Fig. 1. Schematic diagram of EC-DTA probes and furnace. A, EC probe: (1) electrodes; (2) sample disk. B, DTA probe: (3) nickel sample holder; (4) rubber "O" ring. C, furnace.

alumel wires for the differential temperature measurement and a chromel wire (along with one of the alumel wires) which was used for the T_s detection. Both probes were inserted into the ends of the simple tube furnace. The electronic components for the a.c. electrical conductivity and the DTA measurements were the same as previously described [6]. Two X - Y plotters were employed, one each for the EC and DTA measurements.

Procedure

The procedure for the concurrent EC-DTA measurements consisted of preparing the disks of the pure sample or of the sample plus a matrix material (usually KBr). The pressed disks, 1 mm \times 6 mm, were obtained using a commercially available die and hydraulic press. One disk was inserted between the two electrodes of the EC probe, while the other was placed in a Au or Al container and placed on the Ni DTA probe. Both probes were inserted into the tube furnace, which was then flushed with nitrogen gas at a flow rate of 30-40 ml min^{-1} . The furnace heating rate was programmed at about 10°C min^{-1} . All EC measurements were made using an a.c. applied potential of 0.1 V at 100 Hz. No significant changes in the EC curve were observable at frequencies of 1000 or 5000 Hz. The EC curves were, in general, quite reproducible from run to run, a factor which had not been observed previously with the two-wire electrode probe [1].

RESULTS AND DISCUSSION

The use of the concurrent EC-DTA apparatus is illustrated by the curves for guanidine acetate in Fig. 2. The DTA curve shows two endothermic peaks; the first is the result of fusion of the compound, while the second

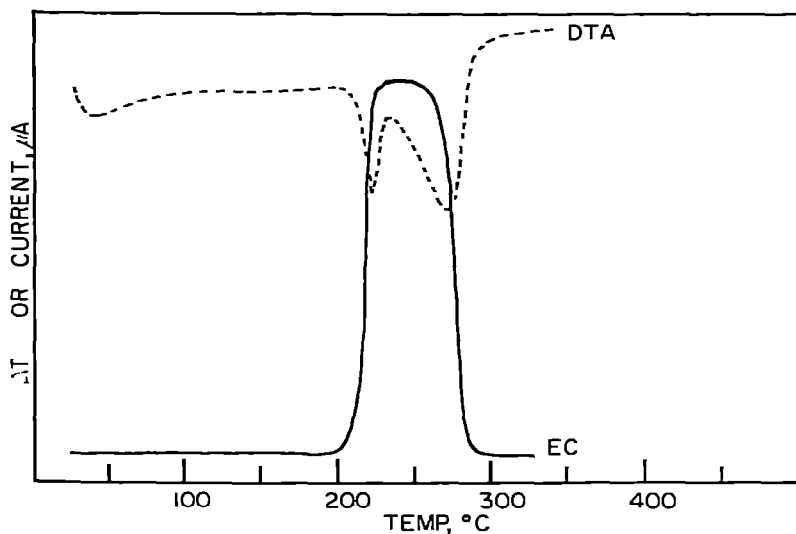

Fig. 2. Concurrent EC-DTA curves for guanidine acetate. Samples were pressed disks consisting of 50% KBr

peak is caused by sublimation and/or decomposition. Only one EC peak, spanning the temperature range 200–300°C was observed for the compound.

This apparatus was used to study the thermal dissociation of a number of cobalt(III) ammine complexes, the results of which will be reported elsewhere.

ACKNOWLEDGEMENT

The financial support of this work by the Robert A. Welch Foundation of Houston, Texas, is gratefully acknowledged.

REFERENCES

- 1 W.W. Wendlandt, *Thermochim. Acta*, 1 (1970) 11.
- 2 J.R. Williams and W.W. Wendlandt, *Thermochim. Acta*, 7 (1973) 261.
- 3 W.W. Wendlandt, *Thermochim. Acta*, 21 (1977) 291.
- 4 W.W. Wendlandt, *Thermochim. Acta*, 30 (1979) 359.
- 5 Z. Halmos and W.W. Wendlandt, *Thermochim. Acta*, 7 (1973) 95.
- 6 W.W. Wendlandt, *Thermochim. Acta*, 26 (1978) 19.