

Note

A THERMOVOLTAIC DETECTOR (TVD) FOR THERMAL DECOMPOSITION REACTIONS

W.W. WENDLANDT

Thermal Analysis Laboratory, Department of Chemistry, University of Houston, Houston, Texas 77004 (U.S.A.)

(Received 1 September 1979)

The use of electrical conductivity (EC) measurements to study the progress of the thermal decomposition of a metal salt hydrate or coordination compound is well established [1–5]. The sample, in powdered or pressed disk form, is placed between two inert metal electrodes which have an applied d.c. or a.c. potential. The current flowing through the sample, I , is then recorded as a function of temperature using an X – Y plotter or other recorder. The conductance of the sample, C , is equal to

$$C = 1/R = I = E/R$$

Since E is essentially constant

$$C = I = k/R$$

The instrumentation for a.c. EC measurements is basically quite simple [3], consisting generally of an audio oscillator, a digital multimeter (DMM) for the current measurement, an X – Y plotter, as well as the sample holder, furnace and temperature programmer. Current flowing through the sample, caused by changes in resistance, R , is detected by the DMM (usually at the microampere level) and recorded, via an analog voltage output, on the Y -axis of the recorder.

Recently, Pillai et al. [6] have investigated the spontaneous current developed by hygroscopic materials such as polymers and metal salt hydrates ($\text{NiSO}_4 \cdot 6 \text{H}_2\text{O}$). These substances, when sandwiched between two dissimilar metal electrodes, generate an electric current (of the order of 10^{-8} – 10^{-10} A) on heating. The curve peaks, especially for $\text{NiSO}_4 \cdot 6 \text{H}_2\text{O}$, were related to the deaquation reactions found by other thermal analysis techniques.

We report here a modification of this technique in that instead of recording the current, the EMF that is spontaneously generated during the course of the thermal decomposition reaction is measured. This technique appears to be applicable to many kinds of thermal decomposition reactions, not just those containing water, as was suggested by Pillai et al. [6]. Since it is potentially a general thermal analysis technique, we would like to propose the name “thermovoltaic detection” (TVD) for it.

EXPERIMENTAL

Apparatus

The sample holder probe and other parts of the apparatus are illustrated in Fig. 1. The sample holder probe is similar to the one previously described for EC studies [7] except that the electrodes are constructed of aluminum and platinum. The sample, in the form of a disk 1 mm thick \times 6 mm in diameter, was prepared using a commercially available die and hydraulic press (Harrick Scientific Corp., Ossining, N.Y.). Other components for the apparatus (B) include a simple tube furnace, a temperature programmer, a digital multi-meter (DMM) (Keithley Model 160B) with a 0–1 V analog output, and an X–Y plotter (Hewlett–Packard Model 7035B). The tube furnace arrangement permits optional concurrent DTA measurements to be made as described previously [7].

Procedure

The sample is prepared in disk form, either in the pure state or mixed with a suitable matrix material such as KBr, KCl, etc. The sample disk is placed between the spring-loaded electrodes of the probe which is then inserted into one end of the tube furnace. After flushing the furnace with dry N_2 at a flow rate of 30–40 ml min^{-1} , the programmer is activated to elevate the furnace temperature at a heating rate of $10^\circ\text{C min}^{-1}$. During the thermal decomposition of the sample, an EMF is generated (usually up to 1 V) which is recorded, via the analog output of the DMM or directly, on the Y-axis of the X–Y plotter. The sample temperature, detected by a thermocouple welded to the nickel backplate, is recorded on the X-axis.

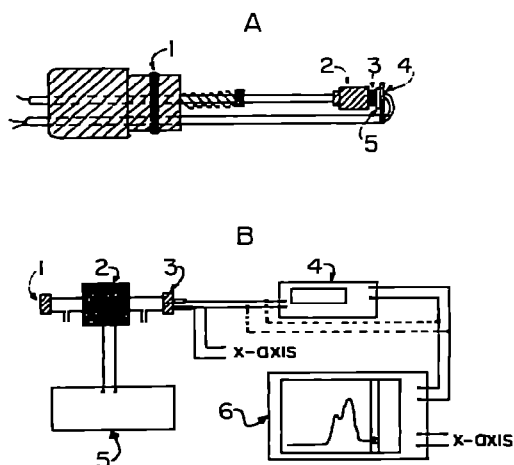

Fig. 1. TVD sample holder probe and apparatus. A, sample holder: (1) "O" ring; (2) Al electrode; (3) sample in disk form; (4) Ni back-plate containing chromel–alumel thermocouple; (5) Pt electrode. B, schematic diagram of apparatus: (1) DTA probe (optional); (2) furnace; (3) TVD probe; (4) DMM; (5) temperature programmer; (6) X–Y plotter (dashed lines indicate direct connection to Y-axis).

RESULTS AND DISCUSSION

The TVD curves of three different compounds are displayed in Fig. 2. Two of the compounds are metal salt hydrates, $\text{NiSO}_4 \cdot 6 \text{H}_2\text{O}$ and $\text{CoSO}_4 \cdot 7 \text{H}_2\text{O}$, while the third is a pyridine complex, $\text{Ni}(\text{py})_4\text{Cl}_2$. For $\text{NiSO}_4 \cdot 6 \text{H}_2\text{O}$, a shoulder peak at 119°C and two peaks at 135 and 160°C , respectively, are observed in the curve. These peak maxima are somewhat different from the values reported by Pillai et al. [6] but agree with the concurrent DTA curve (not shown) obtained on a disk sample at the same heating rate of $10^\circ\text{C min}^{-1}$.

In the case of $\text{CoSO}_4 \cdot 7 \text{H}_2\text{O}$, two major peaks are observed in the TVD curve, at 109 and 122°C , respectively. These two peaks occurred at a much lower temperature than those found in the corresponding DTA curve (136 and 150°C , respectively).

The evolution of water is not necessary in order to generate an EMF from the electrode system employed, as is illustrated by the TVD curves of $\text{Ni}(\text{py})_4\text{Cl}_2$. Two peaks are observed in the curve at 144 and 165°C , respectively. In this temperature range the DTA curve (not shown) contained two endothermic peaks, with peak minima at 144 and 183°C , respectively. It was also found that TVD could be used in the investigation of the thermal decomposition of cobalt(III) ammine complexes; this investigation will be reported later.

The thermovoltaic detector (TVD) appears to have rather general utility in the investigation of certain types of thermal decomposition reaction. Water is not essential for its operation, as was suggested by Pillai et al. [6]. A future report will discuss the generation of the output EMF and the electrode reactions involved.

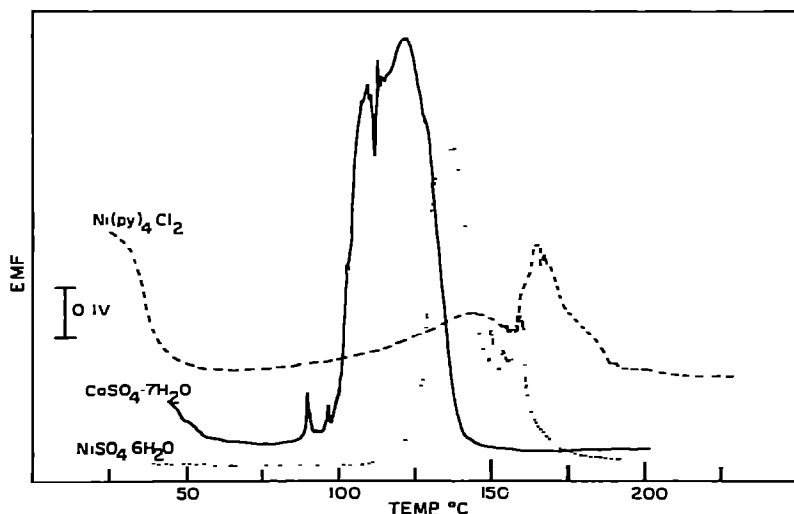

Fig. 2. TVD curves of various compounds. N_2 atmosphere at $10^\circ\text{C min}^{-1}$ on pressed disks of the pure compounds.

ACKNOWLEDGEMENT

The financial support of this investigation by the Robert A. Welch Foundation of Houston, Texas, is gratefully acknowledged.

REFERENCES

- 1 W.W. Wendlandt, *Thermochim. Acta*, 1 (1970) 11.
- 2 J.R. Williams and W.W. Wendlandt, *Thermochim. Acta*, 7 (1973) 261.
- 3 W.W. Wendlandt, *Thermochim. Acta*, 21 (1977) 291.
- 4 W.W. Wendlandt, *Thermochim. Acta*, 26 (1978) 19.
- 5 W.W. Wendlandt, *Thermochim. Acta*, 30 (1979) 359.
- 6 P.K.C. Pillai, S.F. Xavier and M. Mollah, *Thermochim. Acta*, 35 (1980) 385.
- 7 W.W. Wendlandt, *Thermochim. Acta*, 37 (1980) 117.