

## THERMAL ANALYSIS AND XRD STUDIES ON CATALYST SUPPORTS OF POTASSIUM TUNGSTEN BRONZE AND POTASSIUM MAGNESIUM TITANIUM OXIDE.

M.T. Mirza<sup>1</sup>, J.R. Walls<sup>1</sup> and S.A.A. Jayaweera<sup>2</sup>.

<sup>1</sup>Department of Chemical Engineering, Teesside Polytechnic, Middlesbrough, Cleveland, TS1 3BA.

<sup>2</sup>Department of Chemistry, Teesside Polytechnic, Middlesbrough, Cleveland, TS1 3BA.

### ABSTRACT

Two types of mixed oxide compounds ( $K_xWO_3$  and  $K_xMg_yTi_{1-y}O_2$ ), both with high electrical conductivity are described. Their potential use as catalytic materials for cracking of hydrocarbons in a reactor powered by electromagnetic energy is investigated. In particular the heating rates of these materials in an R.F. reactor are reported.

Structural characterisation of the phases was achieved by XRD. It was found that by altering the value of  $x$  in the range  $0.2 < x < 0.8$  the structure changed from hexagonal to tetragonal. The  $KMgTiO_2$  structure was of the hollandite type.

Simultaneous TG and DTA were carried out to characterise the chemical processes involved. Phase changes were investigated over the range 25-800 °C, by heating the samples to different temperatures and by carrying out XRD. Phase stabilities and decomposition reactions of the two compounds are investigated. A comparison between thermal analysis data and electrical conductivity measurements concerning the phase changes in these materials is described.

### INTRODUCTION

A novel three phase reactor system has been developed at Teesside Polytechnic by Walls and Nithiananthan (ref.1). By using electromagnetic radiofrequency heating it is possible to heat a catalyst pellet directly, thus providing the appropriate heat requirement for an endothermic reaction at the point of contact between catalyst and reactants. With this technique it has been possible to steam reform and crack heavy oils and residues without carbon formation being a major problem. A schematic diagram of the reactor is shown in figure 1.

Oil and water are fed to the reactor by means of peristaltic pumps. Steam is generated by a unit consisting of a cylinder surrounded by an electrically heated element rated at 0.8 W. Liquid hydrocarbon was delivered onto a porous quartz sintered disc through which steam was able to pass. Steam and oil were contacted on a packing consisting of glass raschig rings measuring 7 mm x 5 mm. These were located below the heated catalyst, in order to improve the mixing of steam and oil prior to contacting with the catalyst. Reaction occurs in a vapour film surrounding the catalyst surface. All the feedstock is eventually vaporised from this three phase reactor.

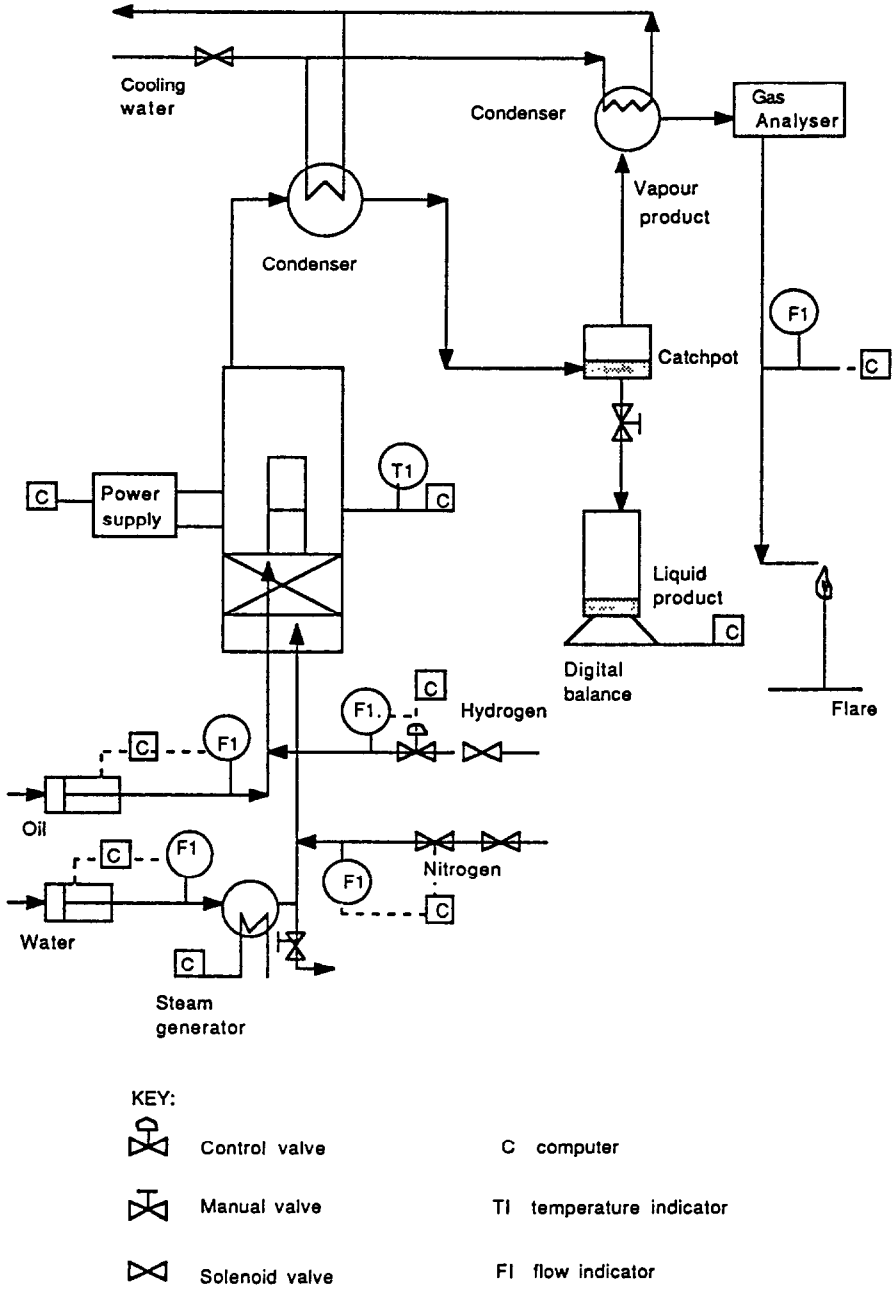

Figure 1: Catalytic cracking using electromagnetic heating.

Two mixed oxide compounds ( $K_xWO_3$  and  $K_xMg_yTi_{1-y}O_2$ ), both with high electrical conductivity were specifically formulated for use in this type of reactor.

## EXPERIMENTAL

### 1. Preparation of catalyst supports in the laboratory.

There are two possible methods which can be used in the preparation of catalyst supports, depending on the requirements. In the present application the interest lay in a large surface area and high porosity.

#### (a) The precipitation method.

This basically involves the mixing together of two or more solutions to give a precipitate under various conditions of temperature and pH. This method was used to prepare the potassium magnesium titanate.

#### (b) Thermal method.

This involves direct heating of the mixture. This method was used in the preparation of potassium tungsten bronzes and the potassium magnesium titanate.

### 2. Preparation of potassium magnesium titanate.

The composition of  $K_xMg_yTi_{1-y}O_2$  had to satisfy the following conditions;

- (i)  $1/2y < x < 1$
- (ii)  $(x-y)/2y = 0.1$

Since an aqueous solution of titanium tetranitrate (the starting material) was not readily available, it had to be synthesised in the laboratory. The necessary steps involved in the preparation are outlined below:

#### (a) Preparation of hydrated titanium oxides.

The precipitate obtained when an alkali metal hydroxide is added to a solution of a titanium(IV) salt consists essentially of hydrated titanium oxide. Its exact composition depends on the conditions under which it precipitates. If precipitation is carried out at room temperature a voluminous and gelatinous precipitate forms which, because of its large surface area, is extremely adsorbent. It is known as orthotitanic acid and has the formula  $TiO_2 \cdot 2H_2O(Ti(OH)_4)$ (ref.2), but it may contain more water than is indicated by the formula. Its adsorbent nature makes it difficult to obtain as a pure compound, and reprecipitation may be necessary to eliminate all of the impurities. If the suspension is boiled or if precipitation is from hot solutions, then a less hydrated oxide forms and is known as metatitanic acid,  $TiO_2 \cdot H_2O(Ti(OH)_2)$ (ref.2). This form is more difficult to dissolve in acid and is only soluble in hydrofluoric or hot concentrated sulphuric acid. Figure 2 shows a schematic representation of the process.

After having obtained the orthotitanic acid, this was dissolved in concentrated nitric acid to give a solution of titanium tetranitrate.

#### (b) Preparation of $K_xMg_yTi_{1-y}O_2$ .

To the previously prepared solution of titanium tetranitrate was added potassium hydroxide and magnesium nitrate solutions (Fig. 3). Initially, this gave a white precipitate, which dissolved on stirring. Following further additions of the two solutions solid

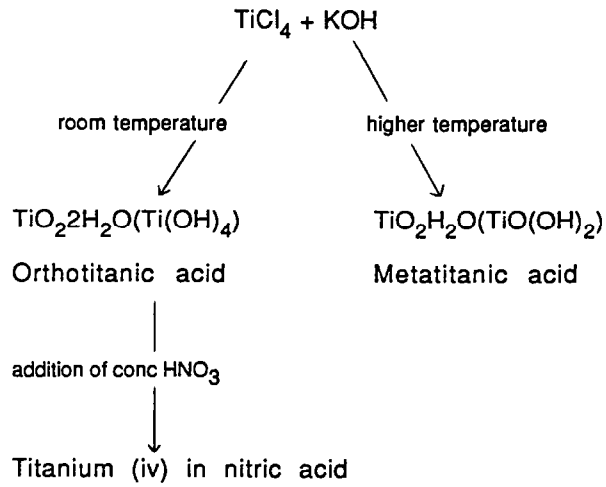

Figure 2: Scheme showing the preparation of  $\text{Ti}(\text{NO}_3)_4$ .

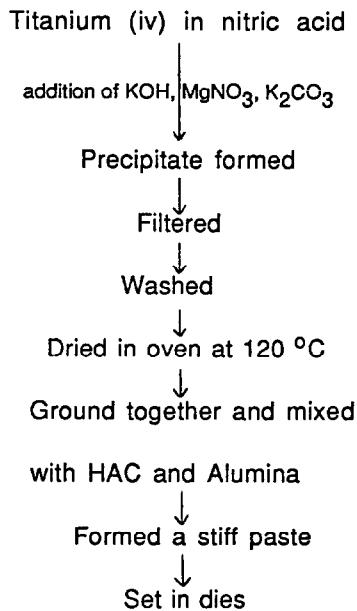

Figure 3: Scheme showing the essential steps involved in the preparation of  $\text{K}_x\text{Mg}_y\text{Ti}_{1-y}\text{O}_2$ .

potassium carbonate was also added to aid precipitation. A greyish-white gelatinous precipitate was obtained.

The precipitate was filtered and washed to eliminate chloride ions left over from the earlier preparation of titanium tetranitrate because these are harmful to the reactivity of the catalyst; it was re-slurried a number of times. The final crystals were needle-like and white in appearance. After drying the crystals at 120 °C, they were ground and mixed with high alumina cement (HAC) and BDH alumina (reagent grade) in a weight ratio of 7:5:8 respectively, to a stiff paste using minimum amount of water (previous experiments (ref.3) have shown this to be the ideal weight ratio requirement for catalysts, which are to be used in the radiofrequency reactor). The paste was set in dies and left to stand over a water bath for four days.

### 3. Preparation of potassium tungsten bronzes by the thermal method.

Although numerous methods have been proposed for the preparation of tungsten bronzes (refs. 3-5), the method of Straumanis (ref.6) is the most versatile method and has been found to produce a wider variety of tungsten bronzes and more reproducible results than could be obtained with other preparative procedures.

Initially potassium tungstate  $K_2WO_4$  was prepared by heating a stoichiometrically equivalent mixture of tungstic oxide ( $WO_3$ ) and potassium carbonate at 800°C for eight hours in a furnace.

The bronzes were prepared according to the equation;

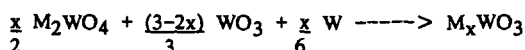

where M = alkali metal (in this case, potassium)

x = the required stoichiometric ratio

The appropriate tungstate, tungstic oxide and tungsten powder were finely ground together and placed in a pyrex boat six inches in length. This in turn was placed in a sealed pyrex tube, which was first flushed with nitrogen and then evacuated by linking to a vacuum pump. The temperature of the furnace was set at 800 °C. After a period of 24 hours, the boat was removed and it was found that the product obtained was fine, crystalline in appearance and violet in colour.

The range of colours varied by bluish-grey to reddish violet as the value of x was changed from 0.25 to 0.80. The cooled crystals were purified by washing in water, potassium hydroxide solution and concentrated hydrofluoric acid. Figures 4 and 5 show the steps involved in the preparation of  $K_xWO_3$  and the experimental set up respectively. The formulated compounds were mixed with alumina and HAC and pelleted. The heating rates, with respect to different power inputs were obtained for these, in the radiofrequency reactor.

A Siemens type F x-ray diffractometer was used for the examination of crystalline powders.  $CuK\alpha$  radiation, of wavelength 1.542 Å, was used. Thermal analysis was carried out on a Stanton Redcroft 781 simultaneous TG and DTA thermal analyser.

Stage 1.Stage 2.

passed nitrogen and evacuated the tube,  $700^\circ\text{C}$  for 12 hrs.

Figure 4: Scheme showing the essential steps involved in the preparation of potassium tungsten bronzes.

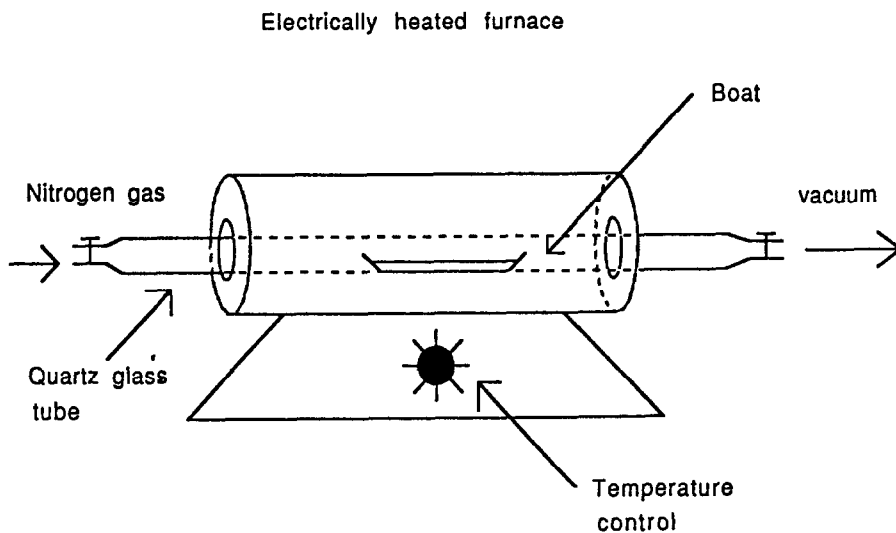

Figure 5: Diagram of the experimental apparatus.

## RESULTS AND DISCUSSION

Pellets of  $K_{0.5}WO_3$ (T1),  $K_{0.25}WO_3$ (T2),  $K_xMg_yTi_{1-y}O_2$ (P2) were tested in the catalytic reactor. Investigation into heating rates was limited by range of the temperature sensor (550–900 °C). T2 pellets failed to register any temperature above 550 °C. The curves obtained for T1 and P2 are given in figures 6 and 7 respectively.

T1 and P2 pellets were also tested for catalytic activity. Product distributions for a variety of feed rates and temperatures were obtained, using Kuwait Wax Distillate as the feedstock for steam reforming. This material has been extensively used by Lee and Acey (refs.7,8) and represents a suitable feedstock for comparing results with those obtained over commercial supported nickel catalysts. The product distribution obtained differed markedly from those obtained over nickel pellets as can be seen from table 1. The striking features about the product distributions for T1 and P2, is the absence of CO and  $H_2S$ . The  $H_2S$  remains in the condensable phase. The production of ethylene, propylene and  $C_4$ 's is considerable greater for T1 and P2 than achieved with the nickel pellets.

The diffraction results obtained were compared with those listed in the "J.C.P.D.S." powder diffraction file. This showed a good correlation and from this it was deduced that the formulated compounds had the following structures:

T1	( $0.5 < x < 0.8$ )	Tetragonal
T2	( $x = 0.25$ )	Hexagonal
P2		Hollandite

### Thermal analysis data for P2.

The DTA trace (fig.8) does not show much detailed structure, except for a sharp peak corresponding to a temperature of 360 °C due to loss of bound water from the compound. The TG trace shows a small amount of weight loss of  $\approx 6\%$  over the temperature range of 35–800 °C. These results show that the compound is stable to high temperatures and does not undergo a large weight loss. Therefore, this compound is suitable for use in the radiofrequency reactor.

### Thermal analysis data for T2.

The TG trace (fig.9) shows no apparent weight loss, indicating that this compound does not undergo any chemical reaction with an increase in temperature of up to 800 °C. A broad endothermic DTA curve is observed, which has a maximum at  $\approx 300$  °C. This is probably due to the migration of potassium ions within the hexagonal cage. A similar phenomenon is observed at  $\approx 700$  °C but this is not pronounced. XRD studies were carried out by heating the compound to correspond to temperature values of interest on the DTA curve (e.g.  $\approx 300$  °C) in a furnace and their XRD pattern was recorded. On comparing the XRD data in conjunction with the DTA trace, it appears that at higher temperatures the compound goes through a definite structural distortion as evident from the appearance of new peaks in the XRD traces. This distortion is probably associated with the hexagonal cage.

### Thermal analysis data for T1.

The DTA and TG traces (fig.10) show similar changes as observed for T2. But

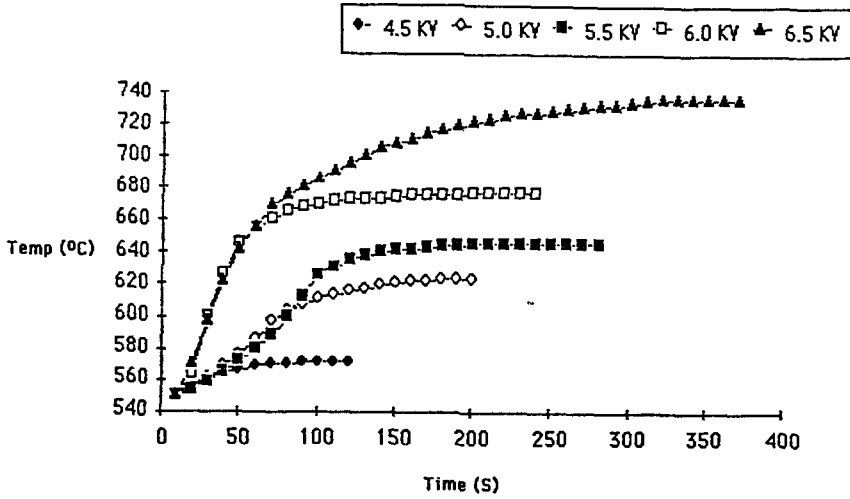

Figure 6: Curves showing rates of heating for T1.

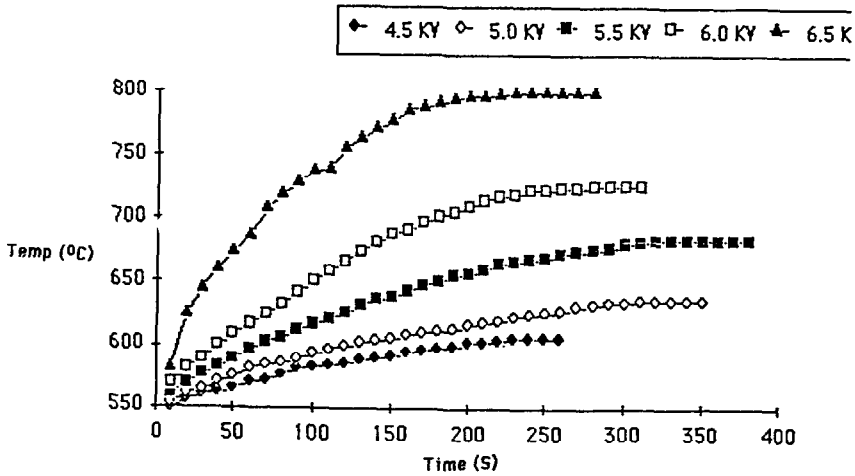

Figure 7: Curves showing rates of heating for P2.



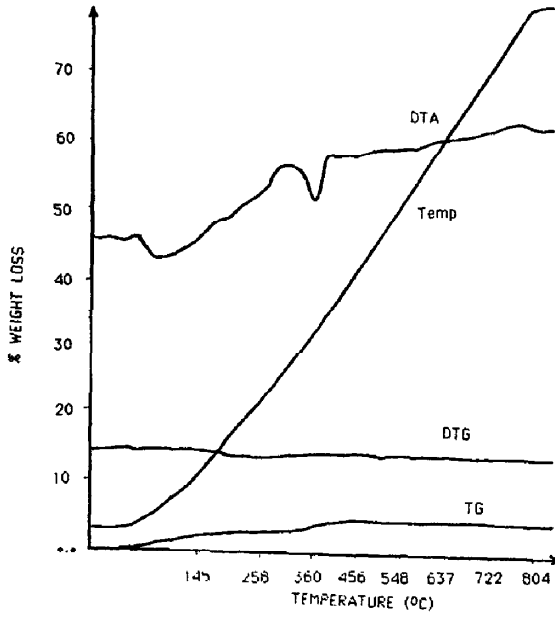

Figure 8: Thermal analysis traces for P2.

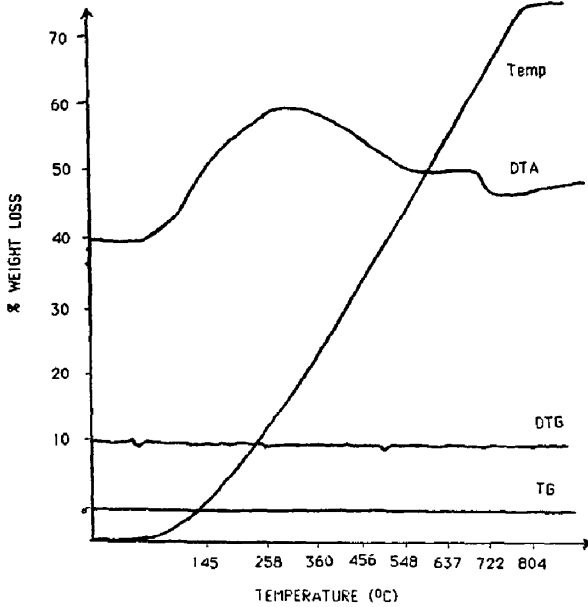

Figure 9: Thermal analysis traces for T2.

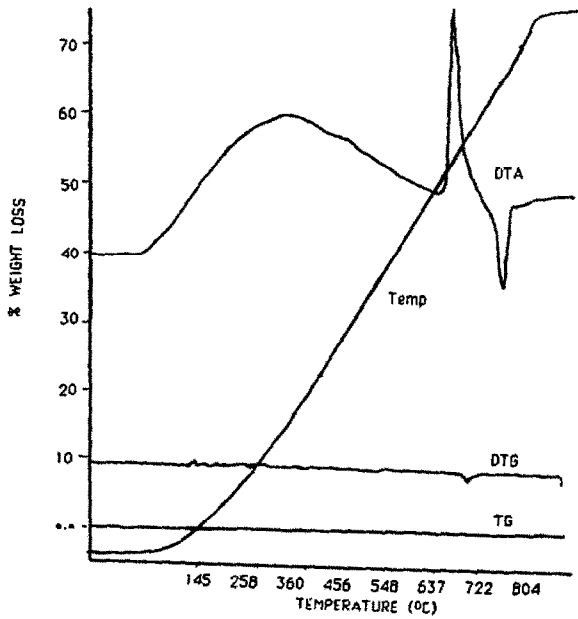

Figure 10: Thermal analysis traces for T1.

wt%	Fe <sub>3</sub> O <sub>4</sub>	Ni	KMgTiO <sub>2</sub>	K <sub>0.5</sub> WO <sub>3</sub>
H <sub>2</sub>	2.81	4.65	5.6	3.45
CO	16.13	9.99	-----	-----
CH <sub>4</sub>	2.62	2.85	3.4	4.32
CO <sub>2</sub>	42.41	32.82	7.71	0.72
C <sub>2</sub> H <sub>4</sub>	5.9	10.43	24.29	20.75
C <sub>2</sub> H <sub>6</sub>	1.76	1.44	2.19	3.05
H <sub>2</sub> S	0.37	1.33	-----	-----
C <sub>3</sub> H <sub>6</sub>	1.55	9.13	24.67	25.68
C <sub>3</sub> H <sub>8</sub>	6.10	-----	2.06	1.85
C <sub>4</sub> 's	9.82	10.77	15.31	30.17
>C <sub>4</sub> 's	10.53	16.63	14.74	9.99
Temp (°C)	671	717	680	700

Table 1: Product distribution results obtained in steam reforming Kuwait Wax Distillate.

here, the changes reflected in the DTA are sharp and well defined at the top end of the temperature range. XRD data also indicate definite structural changes are involved. The other point of interest is the change in the peaks from being endothermic to exothermic at  $\approx 680$  °C and 750 °C respectively.

Conductivity experiments (ref.9) have shown that changes in conductivity occur at similar temperatures as those observed on the DTA curves, corresponding to the changes in the structure of the support materials.

#### CONCLUSIONS

The prepared catalyst supports have shown to be suitable materials for use in the catalytic reactor powered by electromagnetic radiation with different micrometric properties yet to be explored in fuller detail.

#### ACKNOWLEDGEMENT

One of us (MTM) wishes to acknowledge the award of a studentship from the Science and Engineering Research Council.

#### REFERENCES

- 1 Nithiananthan V. PhD. Thesis, Teesside Polytechnic, 1978.
- 2 Encyclopedia of Chemical Technology, vol 23, 131-141.
- 3 A. Magnali, Arkiv Kemi, 1, (1949), 213.
- 4 L.E. Conroy and G. Podolsky, Inorgan. Chem. 7, (1968), 164.
- 5 T.A. Bither, J.L. Gillson and H.S. Young, Inorgan. Chem. 5, (1966), 1559.
- 6 M.E. Straumanis, J.Amer.Chem.Soc, 73, (1951), 5427.
- 7 J. Lee, PhD Thesis, Teesside Polytechnic, 1984.
- 8 S. Acey, PhD Thesis, Teesside Polytechnic, 1986.
- 9 A. Ovenston, private communication.