

## ON CONTINUOUS OXIDE SUPERCONDUCTOR WIRE PREPARATION BY MELT FAST SOLIDIFICATION AND GLASS FORMATION

ZDENĚK STRNAD

*Glass Research Institute of the Glass Works "Sklounion" Teplice, Primátorská 51,  
180 00 Praha 8 (Czechoslovakia)*

JAROSLAV ŠESTÁK

*Institute of Physics of the Czechoslovak Academy of Sciences, Na Slovance 2,  
180 40 Praha 8 (Czechoslovakia)*

(Received 18 September 1989)

### ABSTRACT

Processes for the fabrication of superconducting oxide wires are reviewed by stressing the methods for fibre drawing and/or coating from melts. Solidification studies are discussed as applied to the bismuth–strontium–copper–oxygen (BSCO) and yttrium–barium–copper–oxygen (YBCO) systems, the latter analysed in the framework of phase diagrams. The  $\text{Bi}_2\text{CaSr}_2\text{Cu}_2\text{O}_x$  composition was found to be suitable for forming glass (applying melt–splats quenching at about  $10^3 \text{ K s}^{-1}$ ), exhibiting a glass transition at about  $395^\circ\text{C}$ , crystallization at  $450\text{--}570^\circ\text{C}$  and producing an 80 K superconductor when annealed at about  $810^\circ\text{C}$ .  $\text{YBa}_2\text{Cu}_3\text{O}_x$  and  $\text{Bi}_2\text{CaSr}_2\text{Cu}_2\text{O}_x$  with  $\text{SiO}_2$  and  $\text{B}_2\text{O}_3$  added were used for wire preparation by melt stepwise cooling and dip coating, respectively.

### INTRODUCTION

With respect to subsequent engineering applications the ceramic pellets prepared conventionally via solid state reactions must be assumed to be a necessary preliminary to the development of a technology capable of large-scale and continuous production. Ceramic materials obtained so far are porous and brittle, making fabrication by ordinary mechanical processing difficult, and so are relatively intractable as regards manufacturability. A few other essentially related methods are also reported in recent literature [1], one of the most important utilizing high-temperature reactions to partly or completely liquefy the feed mixture. Advantages of the high-temperature melt process include the capability to make dense specimens and to obtain either the single-crystalline superconducting or partly-crystalline precursor platelets, sheets, ribbons, wires or fibres depending on the cooling rate

applied. We present here some aspects of the ultrafast cooling techniques [2,3] originally developed for the preparation of magnetic glasses [2,4]. A critical survey of the methods for producing glass ceramics, completed by our own data obtained while studying YBCO [5] and BSCO [6] systems, is also presented.

## PROCESSES FOR MAKING OXIDE SUPERCONDUCTING WIRES

Various methods have been proposed and investigated [3,7–10] regarding possible methods for the continuous production of superconducting samples. They can be distinguished as follows:

(1) Metal-clad wires: superconducting ceramic powder is packed into a metal tube, mechanically drawn to the required size and then annealed.

(2) Extruded wires: superconducting powder plus binder is extruded, fired and annealed or directly hot-press formed.

(3) Melt spinning: a melted alloy of predetermined stoichiometry is quenched by spinning on a rotating wheel to form ribbons which are surface-oxidized and annealed.

(4) Metal-core composites: superconducting material is deposited in the form of thin or thick films onto a metal surface, densified, fired and annealed.

(5) Non-metallic-core composites: glassy or glass ceramic fibres are used for coating (and possibly capillaries for filling).

(6) Shock compression: explosive compaction of superconducting powders inside or with metal is used to form a monolith.

(7) Precursor-formed wires: the starting mixture of nitrates, citrates etc. is dehydrated to form viscous melts at relatively low temperatures and drawn prior to crystallization, firing and annealing.

(8) Sol-gel methods: a homogeneous metal alkoxide or salt solution is converted to a viscous sol from which gel fibres are pulled to be transformed to ceramic or glass fibres by heat treatment.

(9) Melt textured growth based on partial melting of sintered preforms during drawing, followed by cooling with a temperature gradient and consequent annealing.

(10) Heating of glass preforms above the glass softening temperature and fibre formation by mechanical drawing followed by thermal treatment.

(11) Melt pulling where the feed mixture (possibly containing modifying and glass-forming additives) is high-temperature melted; drawn filaments are then subjected to controlled solidification, recrystallization and annealing.

Among many others some examples are shown as follows. Method (1) was used early on in the production of usable YBCO superconducting wires and ribbons [8,11–13] as developed by several companies for commercial use.

Recent advances include silver-clad composites of the YBCO mixture with 20 wt.% Ag [13] (to employ the so-called proximity effect where the superconducting state is superimposed into the neighbouring surface of silver grains) or the BSCO materials enriched by 10 mol% of PbO. Suspension spinning [14] has been used to generate wires by extruding YBCO powders mixed with polymers (e.g. PUC) into a precipitating medium. Metallic-core composites [15,16] and laser-heated pedestal growth of BSCO fibres [16] were the focus of much early interest. Rods of BSCO source material were also prepared with a hole along the long axis. Through this hole the support wire was continuously threaded. The rod-top was melted using an annularly focused laser beam to coat the running wire [16]. Less traditional preparative methods have been transferred from such other fields of science as oxide [7] and metallic [2] glasses. For example, the ribbons of metallic glasses prepared by melt spinning of alloy melts of suitable stoichiometry (i.e. the preselected ratio Y : Ba : Cu) were exposed to surface oxidation so as to form layers of YBCO [17–19], which, however, are still too rough for further utilization. The application of sol-gel methods in the preparation of YBCO fibres is also in progress [20,21], but is troubled by the low solubility of cuprates and the porous microstructure of the resulting fibres.

The problem of low current density in traditionally sintered polycrystalline samples ( $I_C \approx 10^2 \text{ A cm}^{-2}$ ) led to increased interest in oriented thin films ( $\gg 10^3 \text{ A cm}^{-1}$ ) [22] and textured growth [23]. This method (9) can produce 100%-dense structures containing oriented crystals (as long as 500  $\mu\text{m}$ ) [9], in which  $I_C$  exceeds  $10^4 \text{ A cm}^{-2}$ . The slow cooling rate requires a temperature gradient of about  $50 \text{ K cm}^{-1}$  down to  $900^\circ\text{C}$  which is too low, however, for large-scale production. The dip-coating technique has been reported to be capable of speeds of up to  $10^3 \text{ mm min}^{-1}$  for withdrawing the coated wires or sheets from melts. Finite lengths were made [15] in which the length limit was determined by the crucible depth used for such a stepwise process.

Instead of a convenient melt, a suspension of superconductor in a suitable carrier can be used (or alternatively replaced by a solid mixture of superconductor with glass or superconductor glass ceramics [8,10]) and subsequently heat-treated to sinter, densify and stick better on the core surface.

#### MELT QUENCHING PROCEDURES

One of the most promising methods (10) is based on a liquid phase process for the solidification [2] of samples capable of exhibiting superconductivity upon suitable thermal treatment [7–10], i.e. (see also Fig. 4)

(i) solidification by self-cooling to room temperature to form 100%-dense polycrystalline material followed by regular two-stage heat treatment to produce the desired superconducting phase;

- (ii) vitrification by ultra-fast cooling to form glass which is then recrystallized; the glass ceramic thus obtained is again subjected to annealing;
- (iii) stepwise crystallization, permitting the material to be annealed during cooling by gradual stopping at the required temperatures.

The first procedure was investigated early on [24–30] and examined with respect to the continuous preparation of thick films [31] and wires [5,23]. Method (ii) was applied to a greater extent to the novel family of BSCO materials [6,26,27,29,32–34], while the third method was suggested for the exploratory production of YBCO wires [8,10].

The cooling rates achieved by individual techniques [2] to freeze-in the high temperature state are very important:

The self-cooling rate of a melt layer adhering on the wall of the sample holder is in the order of  $10 \text{ K s}^{-1}$ .

Liquid immersion or melt pouring onto a metallic plate achieves a rate of about  $10^2 \text{ K s}^{-1}$ .

Splat quenching between two metallic plates gives a maximum of  $10^3 \text{ K s}^{-1}$  [10,24,26,28].

Melt-spinning or roller quenching [10,29,33,34] can provide  $10^4$ – $10^5 \text{ K s}^{-1}$ . The very effective but short-lasting cooling contact between two rotating wheels may cause sample recrystallization due to cooling at lower temperatures after disconnecting the cooling contact [2]. This may be facilitated by subsequently immersing the sample in liquid (e.g. oxygen to ensure simultaneous oxidation [5,10]).

Piston-and-anvil techniques are capable of reaching  $10^6 \text{ K s}^{-1}$ , but provide only low-quality flakes [25].

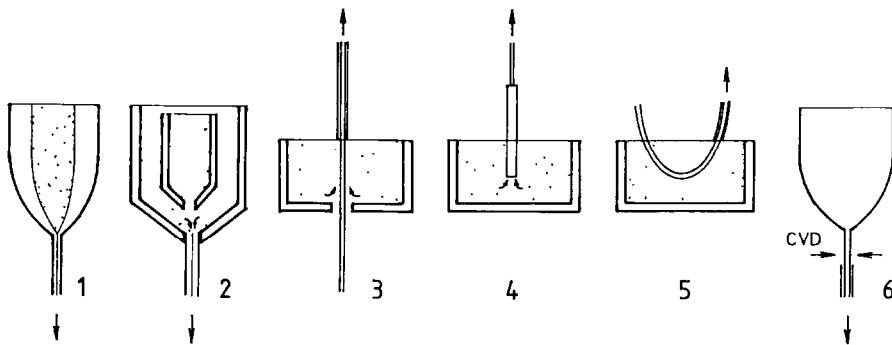

Fig. 1. Methods for the preparation of superconducting wires. (1) Fibre drawing from locally melted or softened solid preform; (2) fibre pulling from melts in a double crucible system; (3) continuous coating of a substrate wire running through the melt-path (or through a hole in locally melted solid preform); (4) wire casting through hollow cylinders (drawing melt up into the warmed tube); (5) dip-coating of substrate wire in discontinuous (finite length) or continuous manner; (6) just-drawn substrate fibres immediately coated by chemical deposition (CVD, MOCVD etc.) or spray pyrolysis.

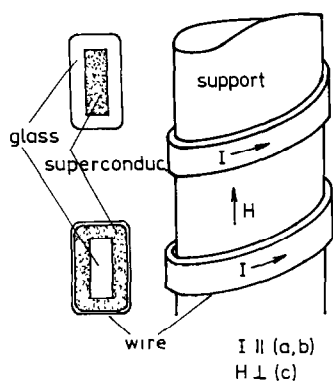

Fig. 2. Superconducting wire profile and mounting. The following characteristics are required for practical applications [9]: high ductility (to be drawn into long lengths); chemical stability (but easy to deposit and protect); mechanical stability; thermal stability (but easy to anneal); rectangular shape with textured microstructure; high critical parameters, such as current  $I_c \approx 10^5 \text{ A cm}^{-2}$  at temperature  $T_c \approx 80 \text{ K}$  and magnetic field  $H_c \approx 2 \text{ T}$ ; not expensive and continuously preparable.

Very effective cooling is achieved during filament pulling, in the order of  $10^3\text{--}10^4 \text{ K s}^{-1}$ , depending on the filament diameter and the cooling fluid stream intensity.

For the continuous preparation of wires we can assume one of the following techniques [5] (see Fig. 1)

- (i) re-melting or softening of pre-solidified glassy or glass-ceramic pre-forms;
- (ii) direct processing of melts;
- (iii) coating of ready-to-use glassy fibres.

The desirable forms of wires for use in superconducting devices are illustrated in Fig. 2. The current passes along the basal ( $a$ - $b$ ) plane while the magnetic field would be perpendicular to the  $c$ -axis. The cross-section of such wires should be as rectangular as possible. The active superconducting material can form either the wire core or mantle.

The annealing process usually requires a free oxygen intake which can only be assured by a certain porosity of mantle glass (e.g. Vycor glass [5]) or by an increased oxygen content (e.g. by excess oxygen dissolved in glass). Moreover the glass must be inert against possible reaction with adhering superconductor where YBCO is particularly reactive due to a high content of BaO and BSCO can easily be contaminated by  $\text{SiO}_2$ . Thus the invert type of glasses (rich in BaO) seems to be the most suitable [10] in this respect. For coating glass fibres (9) a great variety of methods can be used to form thick or thin layers (thin film techniques fall beyond the scope of this article). The core composites (4 and 5) evidently require additional surface protection (e.g. by polymers) after the annealing of mantle superconductor is accomplished.

## SOLIDIFICATION STUDIES APPLIED TO YBCO SYSTEMS

An enormous number of studies (refs. 8 and 35 are reviews) have already been devoted to YBCO systems, including their formation kinetics [29,36,37], conventionally starting from feed mixtures of oxides or carbonates (see Fig.

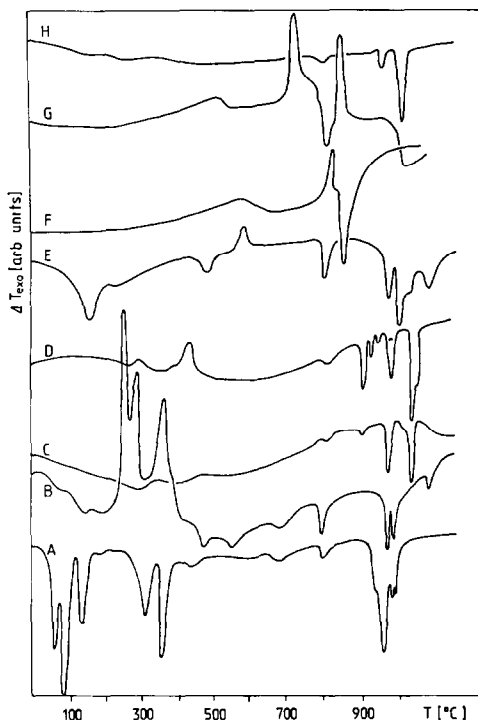

Fig. 3. Thermal properties of  $(\text{YO}_{1.5}) + 2(\text{BaO}_x) + 3(\text{CuO}_x)$  compositions studied by DTA (apparatus by Netzsch, 150 mg samples, heating rate  $5 \text{ K min}^{-1}$ , flowing oxygen, separate platinum cells using  $\text{Al}_2\text{O}_3$  as a reference). (A) Well-homogenised mechanical mixture of  $\text{Ba}(\text{OH})_2/\text{BaO}_2/\text{BaO}$  with  $\text{CuO}$  and  $\text{Y}_2\text{O}_3$  in the required stoichiometric ratio to form  $\text{YBa}_2\text{Cu}_3\text{O}_x$ . Note the formation of liquid phases at around  $100^\circ\text{C}$  and  $400^\circ\text{C}$  [38]. (B) Oxalates coprecipitated from acetate salts in  $\text{C}_2\text{H}_5\text{OH}$  solution to yield stoichiometric  $\text{YBa}_2\text{Cu}_3\text{O}_x$ . Endothermic peak near  $800^\circ\text{C}$  is characteristic for the  $\text{BaCO}_3$  transition [38]. (C) Pre-sintered  $\text{YBa}_2\text{Cu}_3\text{O}_x$  melted at  $1450^\circ\text{C}$  for 1 hr and then splat-quenched. Exothermics at  $300$  and  $500^\circ\text{C}$  are characteristic of copper oxidation [28]. (D) Pre-reacted  $\text{YBa}_2\text{Cu}_3\text{O}_x$  fired at  $1200^\circ\text{C}$  for 48 hrs and self-quenched. Peritectic reactions are evident above  $900^\circ\text{C}$  [28]. (E) Carbonate coprecipitate (from aqueous nitrate solution by adding  $\text{NaHCO}_3$  at pH 5.5 to yield stoichiometric  $\text{YBa}_2\text{Cu}_3\text{O}_x$ ) shows low temperature oxidation of copper ions and complex melting, probably on account of the  $\text{BaO}\cdot\text{BaCO}_3$  compound formed. (F) Well-homogenized mixture of pre-reacted  $\text{YBa}_2\text{Cu}_3\text{O}_x$  with 40 mol%  $\text{SiO}_2$  melted at  $1100^\circ\text{C}$  for 1 hr and poured onto metallic plate to form glass. Crystallization above  $800^\circ\text{C}$  is followed by partial melting [5,10]. (G) Same as (F) but with the addition of 40 mol%  $\text{B}_2\text{O}_3$  and 10 mol%  $\text{SiO}_2$  [5,10]. (H) Pre-reacted  $\text{YBa}_2\text{Cu}_3\text{O}_x$  melted at  $1450^\circ\text{C}$  for 1 hr, self-quenched to  $950^\circ\text{C}$ , annealed for 2 hrs followed by self-cooling in oxygen [10]. Endothermic peaks above  $900^\circ\text{C}$  are characteristic of  $\text{YBa}_2\text{Cu}_3\text{O}_x$  compound [39,40].

3). The resulting superconductors are always contaminated by oxycarbonates [35]. According to phase diagrams [35,41–44] the desired  $\text{YBa}_2\text{Cu}_3\text{O}_x$  phase can exist anywhere below its decomposition temperature of about  $1000^\circ\text{C}$ . Any as-quenched samples from above this temperature cannot show the desired superconductivity because of lack of the  $\text{YBa}_2\text{Cu}_3\text{O}_x$  phase [24,26,28], which can only be formed by solid state reaction above  $800^\circ\text{C}$  [26–28].

It was found, however, that some as yet unidentified phases were formed during ultra-fast quenching ( $10^3\text{--}10^5\text{ K s}^{-1}$ ) and recrystallization [24,28]. Microanalysis and resistivity measurements of quenched and reheated samples [28] showed a positive trend attributed to the development of a phase or phases close to the composition of another (likely superconducting) phase,  $\text{YBa}_4\text{Cu}_2\text{O}_x$  [28,35], but possibly identical to the phase  $\text{YBa}_4\text{Cu}_3\text{O}_x$  [46]

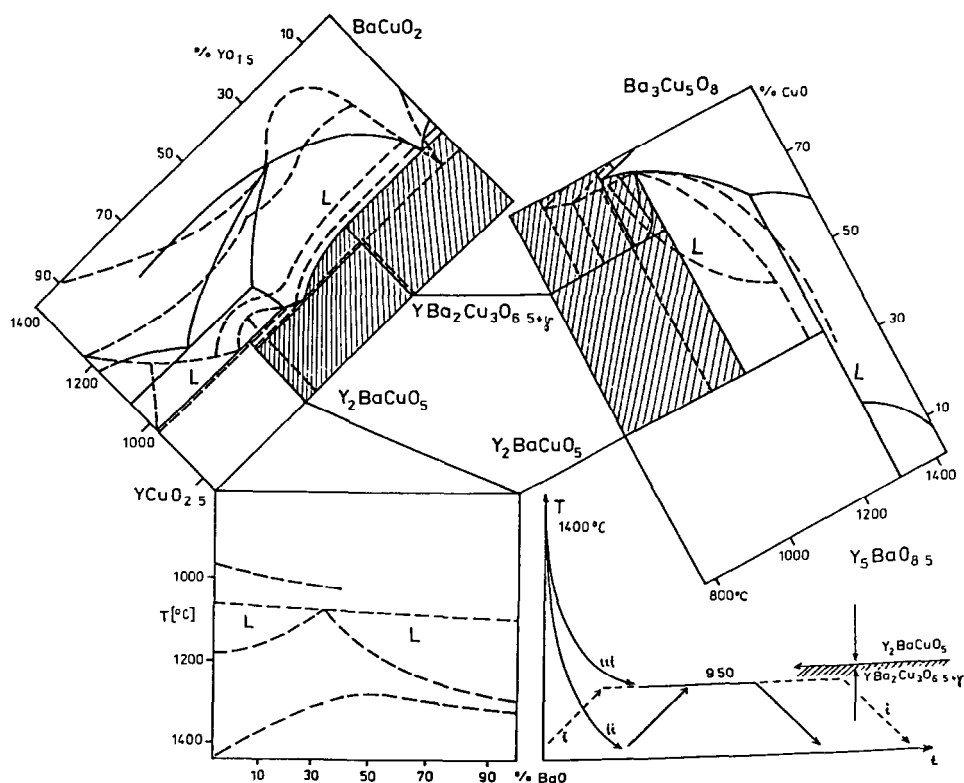

Fig. 4. Pseudo-binary cuts in the central part of  $\text{YO}_{1.5}\text{--BaO--CuO}$  system in air. The region of existence of the superconducting phase  $\text{YBa}_2\text{Cu}_3\text{O}_{6.5+y}$  is hatched. The dashed phase boundary lines are redrawn from ref. 44 with superposed solid lines according to ref. 35. Apparent disagreement in the position of high-temperature phase boundaries demonstrates well the present uncertainty of the YBCO phase determinations [43]. Liquid phase (L) is marked just above  $1000^\circ\text{C}$ . In the bottom right corner the three possible sample thermal treatments are illustrated in the temperature vs. time plots.

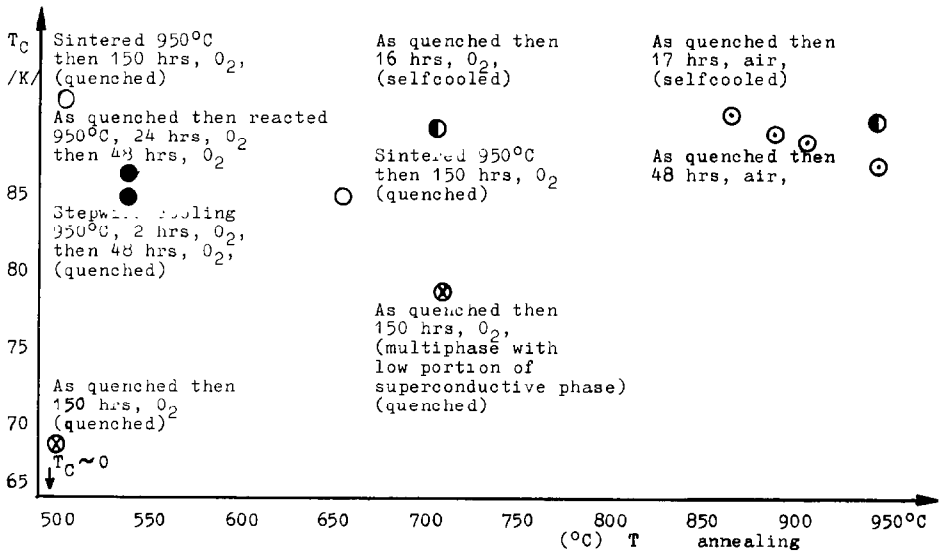

Fig. 5. Critical temperatures ( $T_c$ ) vs. annealing temperatures ( $T$ ) of YBCO samples heat-treated differently.  $\otimes$ , ref. 24;  $\bullet$ , ref. 25;  $\odot$ , refs. 26 and 27; and  $\circ$ ,  $\bullet$ , our measurements.

which is apparently non-superconducting. The variability of the glassy matrix composition does not exclude the possibility of developing a suitable composition to provide a phase exhibiting the desired superconductivity by changing preparation conditions: quenching, reheating, additives. Without the addition of glass-forming oxides, however, attempts to attain glassy  $\text{YBa}_2\text{Cu}_3\text{O}_x$  by the melt extraction of pre-sintered pellets melted by means of an  $\text{H}_2\text{-O}_2$  torch flame rich in  $\text{O}_2$  [24], melt solidification by a modified piston-and-anvil technique [25] or by roller quenching techniques [10,25], even followed by immersion in liquid  $\text{O}_2$  [8], were unsuccessful. This is because the quenching rates remained lower than the required rate of about  $10^6 \text{ K s}^{-1}$  [5]. The only method for the direct preparation of  $\text{YBa}_2\text{Cu}_3\text{O}_x$  superconductor via the melting process is based on its stepwise cooling, whereby the sample temperature is stopped at the temperature required for  $\text{YBa}_2\text{Cu}_3\text{O}_x$  formation, i.e. about  $950^\circ\text{C}$  [45]. Samples treated in this way show critical temperatures comparable with that obtained by ordinary ceramic processing (see Fig. 5).

From the melt quenching method it is evident that the valence state of copper is very important for the subsequent formation of superconductive phases [43]. Oxide additives and feed precursors [38,54] can either increase or decrease the dissociation stability of copper ions. For doped solidified melts good crystal contacts between superconductive components will be essential to retain superconductivity (according to percolation theory the amount of non-superconducting matrix cannot exceed 2/3 of the total [45]). No less important will be the possible incorporation of cations into the



TABLE 1

Phases and glass transformation and critical temperatures [5,47] of the system  $\text{YBa}_2\text{Cu}_3\text{O}_x$  added  $\text{Al}_2\text{O}_3$ ,  $\text{SiO}_2$  and  $\text{B}_2\text{O}_3$ 

| Additives<br>(mol%) | Equilibrated polycrystalline samples |  |                |  | Quenched glassy samples |                   |                   |                |  |
|---------------------|--------------------------------------|--|----------------|--|-------------------------|-------------------|-------------------|----------------|--|
|                     | $\text{AlO}_{1.5}$                   |  | $\text{SiO}_2$ |  | $\text{SiO}_2$          |                   | $\text{BO}_{1.5}$ |                |  |
|                     | $T_c$<br>(K)                         | % of foreign phase<br>$\text{BaAlO}_4$ | $T_c$<br>(K)   | % of foreign phase<br>$\text{Y}_2\text{BaCuO}_5$ | $T_g$<br>(°C)           | $T_{cr1}$<br>(°C) | $T_{cr2}$<br>(°C) | $T_g$<br>(°C)  |  |
| 0.0                 | 91                                   | -                                      | 91             | -  | -                       | -                 | -                 | -              |  |
| 5.66                | 91                                   | -                                      | 91             | -  | -                       | -                 | -                 | - <sup>b</sup> |  |
| 13.0                | 91                                   | -                                      | 92             | -  | -                       | -                 | -                 | -              |  |
| 23.1                | 91                                   | 4                                      | 89             | 8  | 10                      | -                 | -                 | -              |  |
| 37.5                | 91                                   | 9                                      | 91             | 13   | 28                      | 531               | 842               | 914            |  |
| 45.0                | 91                                   | -                                      | -              | -  | -                       | 592               | 846               | 910            |  |
| 54.5                | 91                                   | 18                                     | -              | 17   | 43 <sup>a</sup> (16)    | 584               | 803               | 840            |  |
| 65.0                | -                                    | -                                      | -              | -  | 32 <sup>a</sup>         | 563               | 793               | 840            |  |

<sup>a</sup> Disappearance of the  $\text{YBa}_2\text{Cu}_3\text{O}_x$  phase and the precipitation of  $\text{CuO}$  ( $\text{Cu}_2\text{O}$ ).<sup>b</sup> Although a better glass-formation is generally achieved with the increasing contents of  $\text{B}_2\text{O}_3$  some melting difficulty and immiscibility problems arise at its low contents [56].<sup>c</sup> The glasses become gradually less crystallizable with respect to the desired compounds and also less stable (taking into account the  $T_x - T_g$  values detected by DTA [55]) which is even more effective for the BSCO systems [56].

YBCO structure. Table 1 shows that the addition of  $\text{Al}_2\text{O}_3$  up to 54 mol% or  $\text{SiO}_2$  up to 37.5 mol% [37] does not perturb  $T_c$  (about 91 K) of ceramic mixtures (showing also the ready formation of compounds  $\text{BaAlO}_4$  and  $\text{Y}_2\text{SiO}_7$ , which removes a certain portion of  $\text{BaO}$  or  $\text{Y}_2\text{O}_3$  from the original stoichiometry). In the most heavily doped sample (54.5 mol%  $\text{SiO}_2$ ) the superconduction phase was not formed.

For the formation of the glasses from the melt quenching experiments in air it was found that the addition of 50 mol%  $\text{B}_2\text{O}_3$  or 40 mol%  $\text{SiO}_2$  is necessary when applying a cooling rate of  $10^2$ – $10^3$   $\text{K s}^{-1}$ . When smaller quantities of  $\text{B}_2\text{O}_3$  or  $\text{SiO}_2$  are added the  $\text{Cu}_2\text{O}$  crystallizes out during quenching as the only precipitating phase. It is clear that a large amount of  $\text{Cu}^+$  exists in the melt. The valence state of the copper in the melt is strongly dependent on the melting atmosphere and the melting temperature, usually above  $1300^\circ\text{C}$ , is too high to suppress  $\text{Cu}_2\text{O}$  formation.

For facilitating the pulling out of filaments the problems of melt workability and the relatively low density of as-quenched samples ( $\approx 5.5$   $\text{g cm}^{-3}$ ) must be considered. In Fig. 3 (F and G) two compositions are shown which are workable but unsatisfactory with respect to superconducting phase formation. During annealing of these samples in oxygen (necessary for the formation of  $\text{YBa}_2\text{Cu}_3\text{O}_{6.5+y}$ ) their density increased slightly although holes (pores) up to 10  $\mu\text{m}$  were created, necessary for oxygen intake. On the other hand the polycrystalline superconducting wires fabricated by stepwise molten YBCO processing showed a density as high as  $6.2$   $\text{g cm}^{-3}$  [23,30].

## SOLIDIFICATION STUDIES APPLIED TO THE BSCO SYSTEMS

In general the BSCO system is more easily freeze-in to form glass [29,32,55], on account of the multiple constituents and the presence of  $\text{Bi}_2\text{O}_3$  which is known to act as a glass-former. The system  $\text{Bi}_2(\text{Ca}, \text{Sr})_3\text{Cu}_2\text{O}_8$  shows relatively good compatibility towards modifying additives of oxides, e.g. for a melting temperature of about  $1100^\circ\text{C}$  the addition of up to 5 mol% results [48] in the following changes of critical temperatures  $T_{\text{onset}}$  and  $T_{\text{crit}}$  (90 and 60 K),  $\text{Al}_2\text{O}_3$  (100 and 68 K),  $\text{SiO}_2$  (90 and 36 K),  $\text{B}_2\text{O}_3$  (100 and 66 K),  $\text{P}_2\text{O}_5$  (100 and 81) and  $\text{PbO}$  (115 and 52).

The recently studied compositions  $\text{Bi}_{1.5}\text{CaSrCu}_2\text{O}_x$ ,  $\text{Bi}_{1.5}\text{Ca}_{1.5}\text{SrCu}_2\text{O}_x$  and  $\text{BiAl}_{0.3}\text{CaSrCu}_2\text{O}_x$  exhibited [26,27] the glassy state for splat-quenched samples which annealed (24 hrs at  $820^\circ\text{C}$ ) and showed a higher  $T_c$  and sharper transition than the slowly cooled samples with comparable annealing. Preparation of roller-quenched glassy samples of  $\text{Bi}_2(\text{Ca}, \text{Sr})_3\text{Cu}_2\text{O}_x$  [29,32] showed a more heterogeneous state characterized by two  $T_g$ s [32] and crystallizing at  $500^\circ\text{C}$  to yield the phase  $\text{Bi}_2(\text{Ca}, \text{Sr})_2\text{CuO}_6$  followed at about  $830^\circ\text{C}$  by its dissolution and recrystallization of superconducting

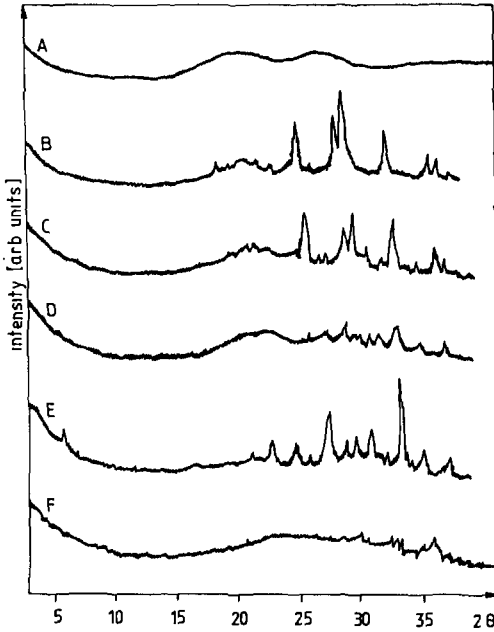

Fig. 6. X-ray powder diffraction patterns of  $\text{Bi}_2\text{CaSr}_2\text{Cu}_2\text{O}_x$  samples. (A) as quenched; (B), (C), (D) and (E) heated to 600, 700, 750 and 800 °C respectively at a heating rate of 2 °C  $\text{min}^{-1}$ ; (F) annealed at 810 °C for 24 hrs.

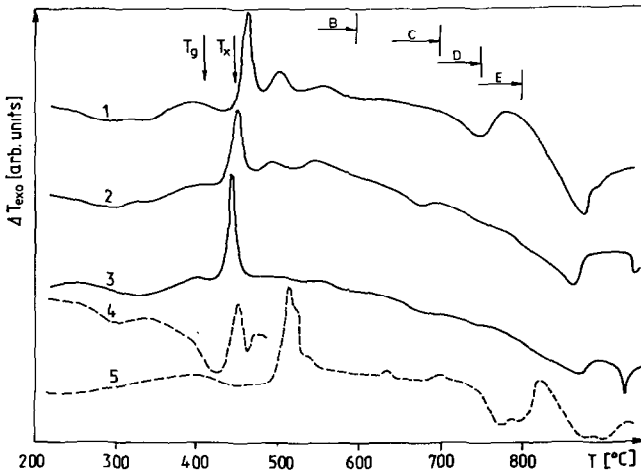

Fig. 7. DTA curves of as-quenched samples (A) with different grain size: (1) 1–1.6 mm, (2) 0.04–0.4 mm and (3) less than 0.04 mm (heating rate 10 °C  $\text{min}^{-1}$ ). Curve (4) corresponds approximately to the DSC of roller-quenched  $\text{Bi}_2\text{CaSr}_2\text{Cu}_2\text{O}_x$  [31] (with unspecified heating rate) while curve (5) corresponds to DTA of  $\text{Bi}_{1.5}\text{CaSrCu}_2\text{O}_x$  [26,27] (heating rate 5 °C  $\text{min}^{-1}$ ).

$\text{Bi}_2(\text{Ca}, \text{Sr})_3\text{Cu}_2\text{O}_8$ . The twin-roller technique was also used to prepare thin sheets (about  $20 \mu\text{m}$ ) of  $\text{Bi}_2\text{Sr}_2\text{CaCu}_2\text{O}_x$  superconductor [34]. Glassy flakes produced by the twin-roller technique were used to check glass-forming regions of the  $\text{Bi}_2\text{O}_3\text{-CuO-(CaO/SrO = 1)}$  system [33]. Glassy coils were prepared by the wire-casting technique (Figs. 1–4) by pumping the  $\text{Bi-SrCaCu}_2\text{O}_x$  melt into quartz tubes [49]. The compositions of  $\text{Bi}_4\text{Sr}_3\text{Ca}_3\text{Cu}_4\text{O}_x$  [50],  $\text{Bi}_2\text{Sr}_2\text{Ca}_3\text{Cu}_4\text{O}_x$  [51] and  $\text{Bi}_{1.6}\text{Pb}_{0.4}\text{Sr}_2\text{Ca}_2\text{Cu}_3\text{O}_x$  [52,53] were studied, the latter exhibiting a  $T_c$  exceeding 100 K.

In our studies [5,6] we investigated the splat-quenched  $\text{Bi}_2\text{CaSr}_2\text{Cu}_2\text{O}_x$  system which exhibited the glassy state (see Fig. 6) and which upon heating (see Fig. 7) showed the glass transition at  $T_g$  and crystallization at  $T_x$ . When heat-treated ( $2^\circ \text{min}^{-1}$ ) up to a given temperature the samples showed a gradual build-up of crystallinity ( $600^\circ\text{C}$  and  $700^\circ\text{C}$ ) followed, however, by the loss of crystallinity, which was associated with indistinct melting (revealed on DTA curves at  $750\text{--}750^\circ\text{C}$ ). The formation of the 202 diffraction line ( $2\theta \approx 5.8^\circ$ , see Fig. 6) at  $800^\circ\text{C}$  indicates the formation of the orthorhombic superconducting phase (lattice parameter  $C \approx 30.8 \text{ \AA}$ ), which is associated with the endothermic effect seen on DTA curves above  $800^\circ\text{C}$  (see Fig. 7). Although the subsequent isothermal annealing at  $810^\circ\text{C}$  is associated with an apparent loss of crystallinity (Fig. 6 (F)), the superconductive glass-ceramic is formed with a value for  $T_{\text{onset}}$  of 100 K and a  $T_c$  value of 80 K. The development of individual states during heat treatments was also studied by complementary four-probe measurements of electrical resistivity (Fig. 8) and scanning electron microscopy (Fig. 9). It can be seen that low temperature crystallization yields a non-superconducting phase which later re-reacts with the remaining glassy matrix to form first the low temperature phase ( $T_c \approx 30 \text{ K}$ ) followed by the development of the high temperature phase ( $T_c \approx 80 \text{ K}$ ). The DTA curves of the powdered samples of different surface areas showed different reactivities, probably attributable to

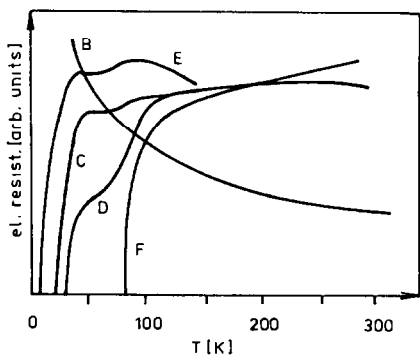

Fig. 8. Temperature dependence of electrical resistivity of the heat treated samples characterized by semiconductor (B) up to low (C and D) and high (F) superconductor behaviour (c.f. Figs. 6 and 7).

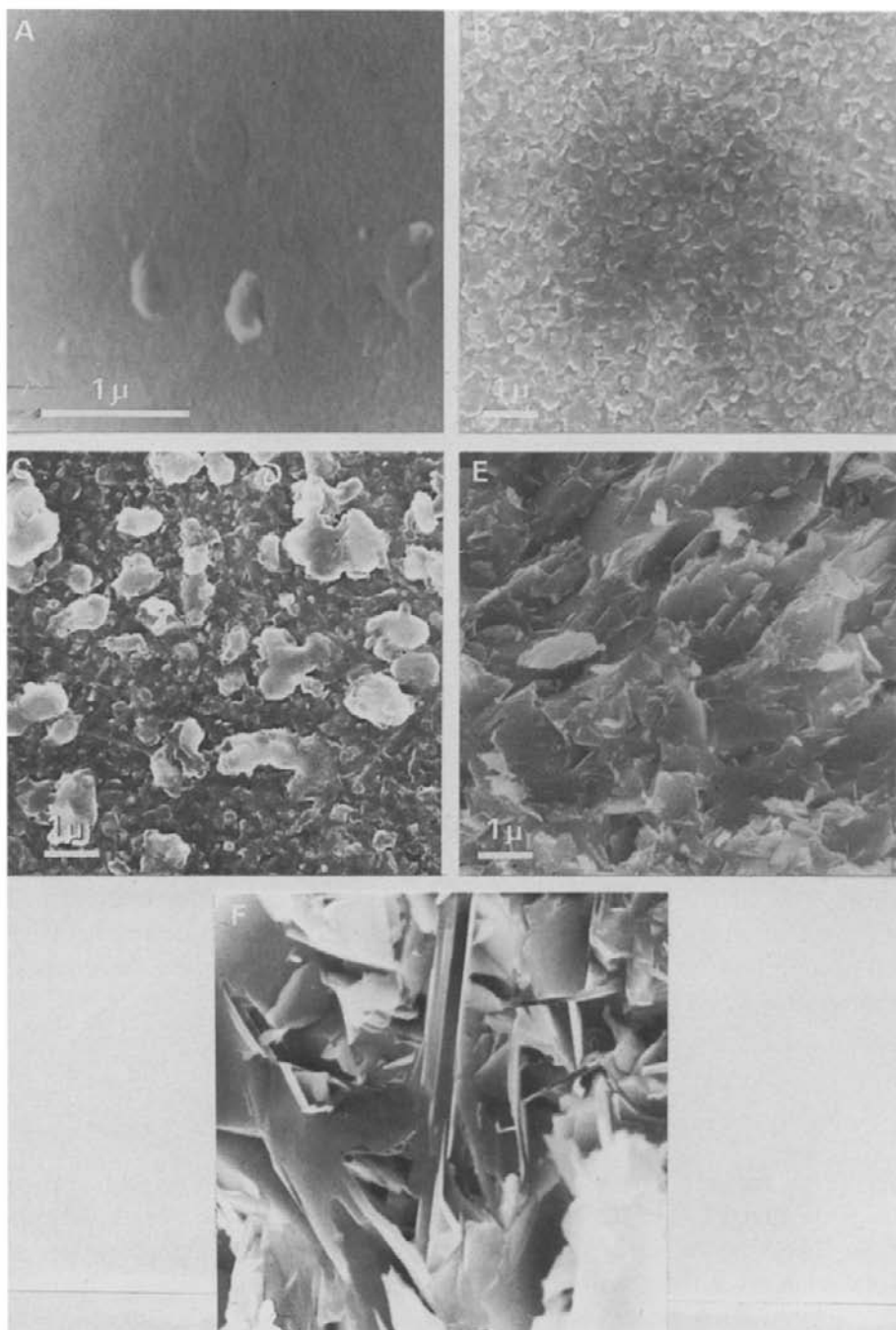

Fig. 9. Electron micrographs of the surfaces of the sample series (A), (B), (C), (E) and (F), c.f. Fig. 6.

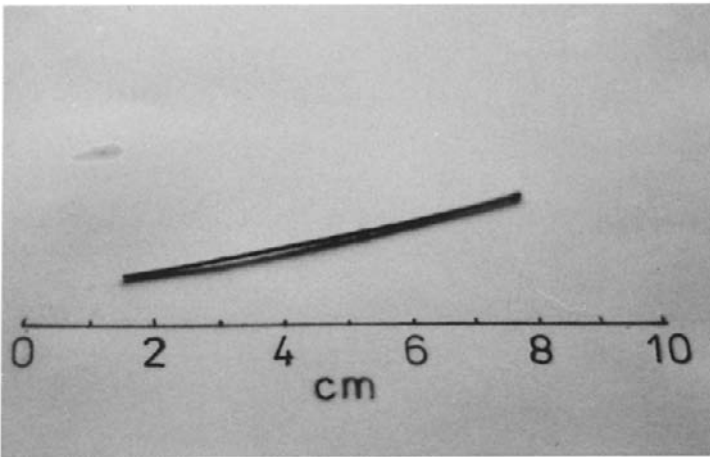

Fig. 10. Picture of a superconducting wire: silver core coated by melt of  $\text{Bi}_2\text{CaSr}_2\text{Cu}_2\text{O}_x$  doped by 10 mol% ( $\text{SiO}_2 + \text{B}_2\text{O}_3 + \text{PbO}$ ) and annealed at  $810^\circ\text{C}$  for 24 hrs.  $T_{\text{onset}} \approx 100\text{ K}$ ,  $T_c \approx 80\text{ K}$ .

different abilities to precipitate, the surface or bulk nucleation possibly producing crystalline phases of different composition. This also becomes the main problem when comparing various DTA curves while having no further details on the sample (e.g. mechanical) treatment (Fig. 6).

The system we investigated showed applicability for trial use in wire production. For direct filament pulling, however, the melts were too fluid (viscosity less than  $10^5\text{ Pa s}$ ). Better workability was achieved by the addition of  $\text{SiO}_2$  and  $\text{B}_2\text{O}_3$  but this destroyed superconductivity. So far the only successful attempt has been the result of dipping silver wire into a melt containing 10%  $\text{SiO}_2$ , in accordance with dip coating experiments described in ref. 15. The wires thus obtained (Fig. 10) were superconducting, with  $T_c \approx 80\text{ K}$  and  $I_c \approx 10^2\text{ A cm}^{-3}$ ; the latter value increased when the method of textured growth in a temperature gradient was applied.

## CONCLUSION

One of the regions where controlled glass crystallization would appear promising is that of the preparation of high-temperature superconducting materials. The advantages of the glass-ceramic route for the preparation of these materials over the common sintering method are not only in shaping, but also in producing materials with increased mechanical strength, uniform structure and zero porosity.

An important precondition for the use of this approach is glass-forming ability in the original melt. The critical cooling rate for glass formation in the  $\text{YBa}_2\text{Cu}_3\text{O}_x$  and  $\text{Bi}_2\text{CaSr}_2\text{Cu}_2\text{O}_x$  systems which were studied in detail in this work are about  $10^6$  and  $10^3\text{ K s}^{-1}$  respectively. The glassy samples in

the BSCO system exhibited glass transition temperatures  $T_g$  of about 395 °C and glass crystallization in the temperature range 450–570 °C, involving first the precipitation of non-superconductive crystalline phases (and also  $\text{Cu}_2\text{O}$ ). Their partial melting occurs in the temperature range 700–750 °C, with the formation of a superconducting phase with a  $T_c$  value of 30 K and later 80 K. The weight increase of the samples heated from room temperature to 750 °C is about 1.4 wt.% as a result of an increase in the oxygen content.

## REFERENCES

- 1 J. Šesták, Z. Strnad and A. Tříska, Special crystalline and noncrystalline materials and their progressive technologies, Academie/Elsevier, Prague/Amsterdam, in print, 1991.
- 2 J. Šesták, *Thermochim. Acta*, 98 (1986) 339 and 110 (1987) 427.
- 3 J. Šesták, *Thermophysical Properties of Solids*, Elsevier, Amsterdam, 1984.
- 4 J. Šesták, V. Šestáková, A. Tříska and K. Závěta, *J. Therm. Anal.*, 33 (1987) 789.
- 5 J. Šesták and Z. Strnad, in O.V. Mazurin (Ed.), *Proc. XVth Congress on Glass Vol. 26*, Nauka Leningrad, 1989, p. 112.
- 6 Z. Strnad and P. Pospíšil, *Phys. Chem. Glasses*, submitted (1990).
- 7 Z. Strnad, *Glass-Ceramic Materials*, Elsevier, Amsterdam, 1987.
- 8 Z. Strnad and J. Šesták, *Oxide ceramic superconductors, a review*, *Sklář a keramik (Prague)*, 38 (1988) 50.
- 9 K. Zannella, lecture at 1st Italian-Czechoslovak Symp. on Superconductivity, Lecco, Italy, June 1989.
- 10 J. Šesták, Z. Strnad and A. Tříska, lecture at 1st Italian-Czechoslovak Symp. on Superconductivity, Lecco, Italy, June 1989.
- 11 R. Flukiger, *Physica C*, 153–155 (1988) 1574.
- 12 H. Sekina, K. Inone, H. Maeda, N. Namata, K. Mori and H. Yamamoto, *Appl. Phys. Lett.*, 52 (1988) 2261.
- 13 V. Pecháček, Z. Trejbalová and I. Snejder, in M. Frumar, V. Černý and L. Tichý (Eds.), *Material Science Monographs*, Elsevier, Amsterdam, 1989.
- 14 T. Gotto and M. Kada, *J. Mater. Res.*, 3 (1988) 1291; *Jpn. J. Appl. Phys.*, 27 (1988) 680.
- 15 T.F. Ciszek and C.D. Evans, in B. McConnet and S. Wolf (Eds.), *Science and Thin-Film Superconductors*, Plenum, New York, 1988.
- 16 D. Gazit, P.N. Deszkin, R.S. Feigelson and T.H. Geballe, *J. Cryst. Growth*, 91 (1988) 467; *Mater. Res. Bull.*, 24 (1989) 467.
- 17 R. Haldar, Y.Z. Lu and B.C. Giessen, *Appl. Phys. Lett.*, 51 (1987) 538.
- 18 V. Hajko, S. Molokáč, P. Diko and K. Czech, *Czech. J. Phys. B*, 37 (1987) 1205.
- 19 H.S. Chen, S.H. Lion, A.R. Kortan, L.C. Kimerling and M. Hong, *Appl. Phys. Lett.*, 53 (1988) 705, 1339; *Phys. Rev. B*, 37 (1988) 9834.
- 20 S. Sakka, H. Kozuka and T. Umeda, *Nippon Ceram.*, 96 (1988) 468.
- 21 T. Umeda, H. Kozuka and S. Sakka, *Advanced Ceram. Mater.*, 3 (1988) 520; *J. Ceram. Soc. Jpn.*, 96 (1988) 355.
- 22 F.H. Chen, H.S. Koo, R.Y. Tseng, R.S. Liu and P.T. Wu, *Mater. Lett.*, 8 (1989) 228; *Chin. J. Phys.*, 26 (1988) S 125.
- 23 J. Jin, T.H. Tiefel, R.C. Sherwood, G.W. Kammlot, M.E. Davies and S.M. Zahurak, *Appl. Phys. Lett.*, 51 (1987) 993, 2074; *Phys. Rev. B*, 1337 (1988) 2074.
- 24 Y. McKittrick, L.Q. Chen, S. Sasayma, M.E. McHenry, G. Kolonji and R.C. O'Handley, in W.Y. Smothers (ed.), *Ceramic Oxide Superconductors I*, *Advanced Ceram. Mater.*, 2 (1987) 353; *J. Appl. Phys.*, 65 (1989) L 41.

- 25 G.V.S. Sastry, R. Wördenweber, K. Heinemann and H.C. Freyhardt, *Physica C*, 153–155 (1988) 1574.
- 26 T. Komatsu, K. Imai, K. Matusita, M. Takata, Y. Iwai, R. Sato, Y. Kaneko and T. Yamashita, *Jpn. J. Appl. Phys.* 26 (1987) L 1148, L 1272, L 1310, L 1384; 27 (1988) L 550.
- 27 T. Komatsu, T. Ohki, K. Imai and K. Matusita, *J. Mater. Sci. Lett.*, 8 (1989) 1; *J. Ceram. Soc. Jpn.*, 97 (1989) 334.
- 28 J. Šesták, M. Nevřiva, E. Pollert, J. Hejtmánek and A. Tříska, *Thermochim. Acta*, 132 (1988) 35.
- 29 M. Tatsumisago, C.A. Augell, Y. Akamatsu, T. Tsuboi, N. Tohge and T. Minami, *Appl. Phys. Lett.*, 54 (1989) 2268, 55 (1989) 600; *Jpn. J. Appl. Phys.*, 27 (1988) L 777; *Ceram. Soc. Jpn.*, 97 (1989) 334.
- 30 D.G. Hinks, L. Soderholm, D.W. Copone, B. Dobrowski, A.W. Mitchell and D. Shi, *Appl. Phys. Lett.*, 53 (1988) 423.
- 31 K. Matsuzaki, A. Inoue, H. Kimura, K. Shimizu and T. Masumoto, *Jpn. J. Appl. Phys.*, 26 (1987) L 1384.
- 32 K.B.R. Warma, K.Y. Rao and C.N.R. Rao, *Appl. Phys. Lett.*, 54 (1989) 69.
- 33 N. Toghe, S. Tsuboi, Y. Akamatsu, M. Tatsumisago and T. Minami, *J. Ceram. Soc. Jpn.*, 97 (1987) 334.
- 34 M. Yoshima, T.H. Sung, Z. Nakagawa and T. Nakagawa, *Jpn. J. Appl. Phys.*, 27 (1988) L 1817.
- 35 J. Šesták, *Thermochim. Acta*, 148 (1989) 235.
- 36 T. Ozawa, *Thermochim. Acta*, 133 (1988) 11.
- 37 A.M. Gadalla and T. Hegg, *Thermochim. Acta*, 145 (1989) 149.
- 38 J. Šesták, T. Hanslík, M. Nevřiva, E. Pollert and A. Tříska, *J. Therm. Anal.*, 33 (1988) 947.
- 39 M. Nevřiva, E. Pollert, J. Šesták and A. Tříska, *Thermochim. Acta*, 127 (1988) 395.
- 40 D. Noël and L. Parent, *Thermochim. Acta*, 147 (1989) 109.
- 41 M. Nevřiva, E. Pollert, J. Šesták, L. Matějková and A. Tříska, *Thermochim. Acta*, 136 (1988) 263.
- 42 G. Krabbes, M. Ritschel, U. Wiesner, E. Wolf and N. Mattern, *J. Therm. Anal.*, 33 (1988) 875.
- 43 J. Šesták, J. Kamarád, P. Holba, A. Tříska, E. Pollert and M. Nevřiva, *Thermochim. Acta*, 174 (1991) 99.
- 44 P.G. Grebeschnikov, G.A. Mikirtischeva, O.G. Schigareva, V.I. Schitova, L.J. Graborenko and S.K. Kuscheva, in N.P. Ljakichev (Ed.), *Proc. Phys. Chemistry and Technology of HTS*, Nauka, Moscow, 1989, p. 51 (in Russian).
- 45 J. Šesták, *Thermochim. Acta*, 148 (1989) 79.
- 46 D.M. de Leeuw, *Physica C*, 158 (1989) 391.
- 47 P.K. Gallagher, in W.Y. Smothers (Ed.), *Ceramic Superconductors I*, *Advanced Cer. Mat.*, 2 (1987) 632, 640, 648.
- 48 J.D. Mackenzie, poster at the XVth Congress on Glass, Leningrad, 1989.
- 49 Y. Abe, H. Hasono, M. Hasoe and Y. Kubo, *Appl. Phys. Lett.*, 53 (1988) 1341.
- 50 H. Zheng and J.D. Mackenzie, *Phys. Rev. B*, 38 (1988) 7166.
- 51 D. Shi, M. Tang, K. Vandervoort and H. Claus, *Phys. Rev. B*, 39 (1989) 9091.
- 52 T. Komatsu, R. Sato, C. Hirose, K. Matusita and T. Yamashita, *Jpn. J. Appl. Phys.*, 27 (1988) L 1839, L 2293; *Appl. Phys. Lett.*, 54 (1989) 1169.
- 53 H. Sato, W. Zhu, M.M. Miller, T. Ishiguro, A.I. Schindler and C.S. Calhoun, *J. Solid State Chem.*, 79 (1989) 146.
- 54 G. Braun, G. Schuster, H. Ullmann, W. Matz and K. Henkel, *Thermochim. Acta*, 165 (1990) 261.
- 55 J. Šesták, Oxide melt fast solidification as a route to prepare HTS, in V. Narlicar (Ed.), *Studies on High  $T_c$  Superconductors*, Vol. 8, Nova, New York, in press.
- 56 A. Bhargava, L. Snijder, K. Varshneya, *Mater. Lett.* 7 (1988) 185 and 8 (1989) 425.