

## Theory of power-compensated DSC

Satohiro Tanaka

*National Chemical Laboratory for Industry, 1-1 Higashi, Tsukuba, Ibaraki 305 (Japan)*

(Received 12 March 1992)

### Abstract

Theoretical analysis of two systems of power-compensated DSC is presented; one is a system with proportional temperature control of the sample holder and the other is with PID (proportional, integral and differential) temperature control of the sample holder.

Power-compensated DSC is designed to measure directly and exactly the enthalpy change of the sample holder as a function of time. However, the measured output signal in both systems is not exactly equal to the enthalpy change of the sample holder. When there is an input signal, the enthalpy change of the sample holder is a step function of time, and the output signals in both systems are examined. The output signal in the system with proportional temperature control of the sample holder gradually approaches the input signal as time increases but does not converge uniformly to the input signal. The output signal in the system with PID temperature control of the sample holder shows time delay and an overshoot or damped vibration depending on the values of control parameters.

A proportionality relation between total enthalpy change of the sample holder and peak area of the output signal is valid in both systems.

### INTRODUCTION

Two types of differential scanning calorimeter (DSC) are widely used in studying thermal properties of materials: heat-flux DSC and power-compensated DSC [1]. Heat-flux DSC measures the temperature difference  $T_s - T_r$ , where  $T_s$  is the temperature of the outside surface of the sample holder and  $T_r$  is that of the reference holder. A schematic representation of heat-flux DSC is shown in Fig. 1. Power-compensated DSC measures the differential electric power  $p_s - p_r$  required to keep both sample and reference holders at the same temperature throughout the entire analysis, where  $p_s$  is the electric power fed to the sample holder and  $p_r$  is that fed to the reference holder. Figure 2 shows a schematic representation of a power-compensated DSC system. The difference between the operational principles of the two types of DSC is easily seen in Figs. 1 and 2.

Watson et al. described the system of power-compensated DSC [2] and

---

*Correspondence to:* S. Tanaka, National Chemical Laboratory for Industry, 1-1 Higashi, Tsukuba, Ibaraki 305, Japan.

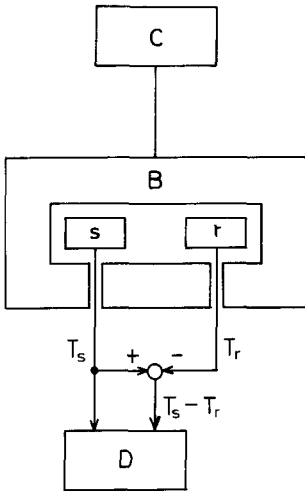

Fig. 1. Schematic diagram of heat-flux DSC system: s, sample holder; r, reference holder; C, programmed temperature controller; B, surrounding block; D, display;  $T_s$ , temperature of the sample holder;  $T_r$ , temperature of the reference holder.

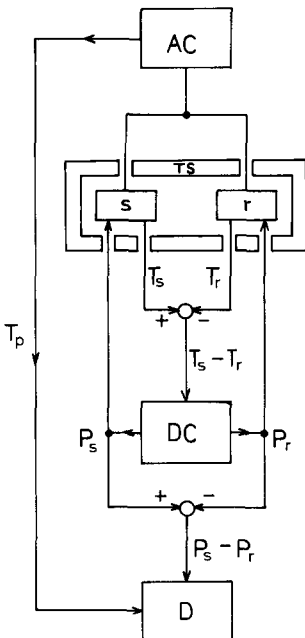

Fig. 2. Schematic diagram of power-compensated DSC system: s, r,  $T_s$ ,  $T_r$  and D are the same as in Fig. 1;  $p_s$ , electric power fed to the sample holder;  $p_r$ , electric power fed to the reference holder;  $T_p$ , programmed average temperature of the sample holder and the reference holder; AC, programmed average temperature controller; DC, difference temperature controller; TS, thermal shield.

O'Neill treated theoretically the system with proportional temperature control of the sample holder surface [3]. After O'Neill's theoretical treatment, no author has elucidated the behavior of the control system, while some authors presented generalized theories of both types of DSC without providing any insights into the control system [4–6]. Here, we treat the control system of power-compensated DSC described by Watson et al. [2] and O'Neill [3] and investigate the response behavior of the output signal in DSC when a thermal change occurs in the sample holder.

### PROPORTIONAL TEMPERATURE CONTROL OF SAMPLE HOLDER

We now consider a system of sample holder with power compensation control under constant environment temperature  $T_E$  similar to the one investigated by O'Neill [3]; a block diagram of the system is shown in Fig. 3.

For an infinitesimal time interval  $dt$ , application of the first law of thermodynamics to the sample holder gives

$$\frac{dH}{dt} = \frac{dQ}{dt} + \frac{dW}{dt} \quad (1)$$

where  $H$  is the enthalpy of the sample holder,  $Q$  is the heat transferred to the sample holder and  $W$  is the electrical work done on the sample holder. In our discussion, "sample holder" refers to the sample and the holder taken together.

The enthalpy of the sample holder  $H$  is determined by two thermodynamic variables, namely the extent of reaction  $\xi$  and the temperature  $T$ .

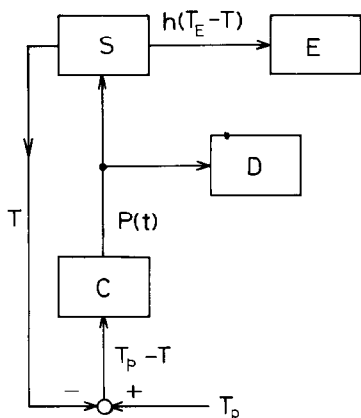

Fig. 3. Block diagram of power-compensated sample holder system: S, sample holder; C, temperature controller; D, display; E, environment;  $T$ , temperature of the sample holder;  $T_p$ , programmed temperature;  $T_E$ , temperature of the environment;  $h$ , heat transfer coefficient;  $P(t)$ , electric power fed to the sample holder.

Then, we have  $H = H(\xi, T)$  and

$$\begin{aligned} \frac{dH}{dt} &= \frac{\partial H}{\partial \xi} \frac{d\xi}{dt} + \frac{\partial H}{\partial T} \frac{dT}{dt} \\ &= v(t) + C \frac{dT}{dt} \end{aligned} \quad (2)$$

where

$$v(t) = \frac{\partial H}{\partial \xi} \frac{d\xi}{dt} \quad (3)$$

is the rate of enthalpy change caused by chemical reaction or physical phase change of the sample, and

$$C = \partial H / \partial T \quad (4)$$

is the heat capacity of the sample holder.  $dQ/dt$  is the rate of heat flow to the sample holder and is given by

$$dQ/dt = h(T_E - T) \quad (5)$$

where  $h$  is the heat transfer coefficient and  $T_E$  is the temperature of the environment.  $dW/dt$  is the electric power  $P(t)$  which compensates the thermal change of the sample holder and is assumed to be

$$dW/dt = P(t) = K(T_p - T) \quad T_p > T \quad (6)$$

$$= 0 \quad T_p < T \quad (7)$$

where  $K$  is constant and  $T_p$  is the programmed temperature. Because the electric power is always positive,  $P(t)$  should be set to be zero for  $T_p < T$ . Thus, when the temperature of the sample holder  $T$  is lower than the programmed temperature  $T_p$ ,  $T$  approaches  $T_p$  by losing energy to the environment with heat flow rate of  $h(T_E - T)$ . From eqns (1)–(5), we have

$$v(t) + C \frac{dT}{dt} = h(T_E - T) + P(t) \quad (8)$$

We investigate here the system in the case where the programmed temperature  $T_p$  changes linearly with time  $t$  at a rate  $\alpha$

$$T_p = T_{p0} + \alpha t \quad (9)$$

and

$$T_p > T > T_E = \text{constant} \quad (10)$$

When no chemical and physical change of the sample occurs, we assume that the system is in a steady state and the temperature of the sample holder changes linearly with time at the same rate  $\alpha$  as the

programmed temperature. In the steady state, eqns (6) and (8) become

$$P_{ss}(t) = K(T_p - T_{ss}) \quad (11)$$

$$C \frac{dT_{ss}}{dt} = h(T_E - T_{ss}) + P_{ss}(t) \quad (12)$$

where the subscript ss denotes the quantity in the steady state. Subtracting eqn. (12) from eqn. (8), and eqn. (11) from eqn. (6), we have

$$v(t) + C \frac{d\theta}{dt} = -h\theta + p(t) \quad (13)$$

and

$$p(t) = -K\theta \quad (14)$$

where

$$\theta = T - T_{ss} \quad (15)$$

$$p(t) = P(t) - P_{ss}(t) \quad (16)$$

Eliminating  $\theta$  from (13) and (14), we get

$$v(t) = \frac{C}{K} \frac{dp(t)}{dt} + \frac{(h + K)}{K} p(t) \quad (17)$$

When  $p(t)$  is recorded as a function of time, the recorded curve deviates from zero line position to form a peak or a step due to the enthalpy change of the sample  $v(t)$ . Hereafter,  $v(t)$  refers to the input signal of the DSC system and  $p(t)$  to the output signal of the system.

The objective of power-compensated DSC is to measure directly the enthalpy change of the sample as a function of time. It is desired that the output signal  $p(t)$  of the DSC follows the input signal  $v(t)$  as precisely as possible. Then, it is necessary to compare input signal  $v(t)$  and output signal  $p(t)$  as a function of time. In the problem of analysis of a measuring system, a test input signal is applied to the system, and the performance of the system is evaluated by studying the output response of the system as a function of time. The step function

$$\begin{aligned} v(t) &= v_0 & t > 0 \\ &= 0 & t < 0 \end{aligned} \quad (18)$$

where  $v_0$  is a constant, is useful as a test signal since the response to such an initial instantaneous jump reveals a great deal about the rate at which a system responds.

Starting at the initial condition

$$p(t) = 0 \quad t < 0 \quad (19)$$

and solving eqn. (16) when  $v(t)$  is given by eqn. (18), we get the step

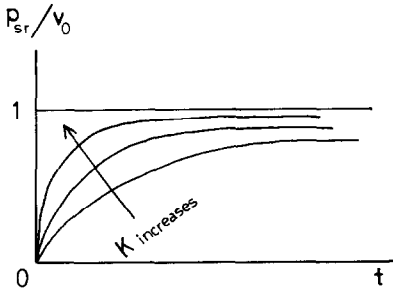

Fig. 4. Illustrative behavior of output response signal (20) to step input signal (18). The response approaches the input signal as  $K$  increases but does not converge uniformly to the input signal.

response of the system  $p_{sr}(t)$

$$p_{sr}(t) = \frac{v_0 K}{K + h} (1 - e^{-t/\tau}) \quad (20)$$

where

$$\tau = C/(K + h) \quad (21)$$

Figure 4 illustrates the behavior of response (20) to step input signal (18). The response cannot follow a sudden change in the input instantaneously; it shows transient behavior and approaches the steady state as the time becomes very large.

$$\begin{aligned} \lim_{t \rightarrow \infty} p_{sr}(t) &= p_{sr}(\infty) \\ &= K v_0 / (K + h) \end{aligned} \quad (22)$$

The output response approaches the level of the input signal as  $K$  increases but it does not converge uniformly to the input signal.

#### PID CONTROL OF TEMPERATURE OF SAMPLE HOLDER

No authors describe any method of temperature control other than proportional temperature control in DSC. PID temperature control is widely used in practise, where PID stands for proportional integral derivative. It is thus necessary to examine PID control in DSC.

Instead of proportional temperature control given by eqns (6) and (7), the following PID control is assumed

$$P(t) = K_P(T_p - T) + K_I \int_0^t (T_p - T) dt + K_D \frac{d(T_p - T)}{dt} \quad T_p > T \quad (23)$$

$$= 0 \quad T_p < T \quad (24)$$

where  $K_P$ ,  $K_I$  and  $K_D$  are constant.

Condition (10) is also assumed here.

When  $v(t) = 0$ , a steady state given by eqn. (12) and

$$P_{ss}(t) = K_P(T_p - T_{ss}) + K_I \int_0^t (T_p - T_{ss}) dt + K_D \frac{d(T_p - T_{ss})}{dt} \quad T_p > T_{ss} > T_E \quad (25)$$

is assumed. Then we have

$$\begin{aligned} p(t) &= P(t) - P_{ss}(t) \\ &= -K_P \theta - K_I \int_0^t \theta dt - K_D \frac{d\theta}{dt} \end{aligned} \quad (26)$$

where  $\theta$  is given by eqn. (15). Equation (13) is also valid here for PID control.

It is necessary to obtain a relation between input signal  $v(t)$  and output recording signal  $p(t)$  by eliminating  $\theta$  from eqns (13) and (26). To eliminate variable  $\theta$  from the differential integral equations, it is useful to apply the Laplace transform method [7]. Applying the Laplace transform to eqns (13) and (26) with zero initial conditions (i.e. the related functions  $v(t)$ ,  $p(t)$  and their derivatives  $v'(t)$ ,  $p'(t)$  are all zero at  $t = 0$ )

$$\bar{v}(s) + Cs\bar{\theta}(s) = -h\bar{\theta}(s) + \bar{p}(s) \quad (27)$$

$$\bar{p}(s) = -K_P\bar{\theta}(s) - K_I\bar{\theta}(s)/s - K_Ds\bar{\theta}(s) \quad (28)$$

where  $s$  is a parameter in the Laplace transform, and  $\bar{v}(s)$ ,  $\bar{\theta}(s)$  and  $\bar{p}(s)$  are the Laplace transforms of  $v(t)$ ,  $\theta(t)$  and  $p(t)$  respectively. Eliminating  $\bar{\theta}(s)$  from eqns. (27) and (28), we get

$$\bar{p}(s) = \frac{K_Ds^2 + K_Ps + K_I}{(K_D + C)s^2 + (K_P + h)s + K_I} \bar{v}(s) \quad (29)$$

For step function input (18),  $\bar{v}(s) = v_0/s$ , eqn. (29) becomes

$$\bar{p}_{sr}(s) = \frac{K_Ds^2 + K_Ps + K_I}{(K_D + C)s^2 + (K_P + h)s + K_I} \frac{v_0}{s} \quad (30)$$

where  $\bar{p}_{sr}(s)$  is the Laplace transform of step response  $p_{sr}(t)$ .

The values of  $p_{sr}(0)$  and  $p_{sr}(\infty)$  can be obtained easily from eqn. (30) by applying the initial-value theorem and the final-value theorem [8]

$$p_{sr}(0) = \lim_{s \rightarrow \infty} s\bar{p}_{sr}(s) = \frac{K_D}{K_D + C} v_0 \quad (31)$$

$$p_{sr}(\infty) = \lim_{s \rightarrow 0} \bar{p}_{sr}(s) = v_0 \quad (32)$$

Equation (32) shows that the limiting value of  $p_{sr}(t)$  as time goes to infinity is identical with the input signal  $v_0$ .

To obtain detailed information on how output signal  $p_{sr}(t)$  varies with time, it is necessary to carry out the inverse Laplace transform of eqn.

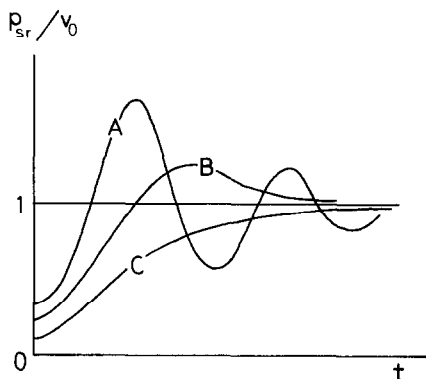

Fig. 5. Three typical curves of step response  $p_{sr}(t)$  of which the Laplace transform is given by eqn. (30). When the two roots of characteristic eqn. (33) are imaginary,  $p_{sr}(t)$  shows damped vibration (curve A). When the two roots are real, it shows gradual approach to input signal (18) with or without an overshoot as  $t$  increases (curves B and C).

(30) with the help of the Laplace transform table [9]. The result of carrying out the inverse Laplace transform of eqn. (30) is not simple and the behavior of the resulting output signal  $p_{sr}(t)$  varies to a great extent depending on the values of the parameters  $K_P$ ,  $K_I$  and  $K_D$ . We cannot determine exactly the variation of the output signal as a function of time, because the values of the parameters have not been described in the literature. However, the system of which the Laplace transform is given by eqn. (29) is called a second-order system and the important features of the behavior of the output signal  $p_{sr}(t)$  are studied in relation to the characteristic eqn. (33) of the system [10]

$$\Delta = (K_D + C)s^2 + (K_P + h)s + K_I = 0 \quad (33)$$

When the two roots of eqn. (33) are imaginary,  $p_{sr}(t)$  shows damped vibration. When the roots are real, it gradually approaches  $v_0$  with or without an overshoot. Figure 5 illustrates three typical curves of  $p_{sr}(t)$ .

#### PROPORTIONALITY RELATION BETWEEN TOTAL ENTHALPY CHANGE AND PEAK AREA

By assuming the condition

$$p(0) = p(\infty) = 0 \quad (34)$$

and that the integrals take finite values, we get eqn. (35) by integrating eqn. (17)

$$\Delta H = \int_0^{\infty} v(t) dt = \frac{(h + K)}{K} \int_0^{\infty} p(t) dt \quad (35)$$

where  $\Delta H$  is the overall enthalpy change and  $\int_0^{\infty} p(t) dt$  is the peak area in a chart recording variation of output signal  $p(t)$ .



Rewriting eqn. (29), we have

$$K_D s^2 \bar{v}(s) + K_P s \bar{v}(s) + K_I \bar{v}(s) = (K_D + C) s^2 \bar{p}(s) + (K_P + h) s \bar{p}(s) + K_I \bar{p}(s) \quad (36)$$

Applying the inverse Laplace transform to the both sides of eqn. (36) under zero initial conditions, we obtain

$$K_D \frac{d^2 v(t)}{dt^2} + K_P \frac{dv(t)}{dt} + K_I v(t) = (K_D + C) \frac{d^2 p(t)}{dt^2} + (K_P + h) \frac{dp}{dt} + K_I p(t) \quad (37)$$

Assuming conditions

$$v(0) = v'(0) = v(\infty) = v'(\infty) = 0 \quad (38)$$

$$p(0) = p'(0) = p(\infty) = p'(\infty) = 0 \quad (39)$$

and that the integrals take finite values, we get eqn. (40) by integrating both sides of eqn. (37)

$$\Delta H = \int_0^\infty v(t) dt = \int_0^\infty p(t) dt \quad (40)$$

Both eqns. (35) and (40) show that the peak area of the output signal is proportional to the enthalpy change. Equation (40) shows that the peak area of the output signal from a PID temperature controlled sample holder is exactly equal to the enthalpy change, while eqn. (35) shows that the peak area of the output signal from a proportional temperature controlled sample holder is not exactly equal to the enthalpy change and that a calibration experiment is required for exact measurement of the enthalpy change from observed peak area in the proportional temperature controlled system.

When the input signal and the output signal are not continuous at  $t = 0$ , for example if there is a pulse or step function of  $t$ , a more sophisticated treatment has to be given and the proportional relation is also valid in a system represented by a linear ordinary differential equation with constant coefficients [11].

## REFERENCES

- 1 W.W. Wendlandt, *Thermal Methods of Analysis*, Wiley-Interscience, New York, 3rd edn., 1985, p. 266.
- 2 E.S. Watson, M.J. O'Neill, J. Justin and N. Brenner, *Anal. Chem.*, 36 (1964) 1233.
- 3 M.J. O'Neill, *Anal. Chem.*, 36 (1964) 1238.
- 4 A.P. Gray, in R.F. Porter and J.M. Johnson (Eds.), *Analytical Calorimetry*, Plenum, New York, 1968, p. 209.
- 5 S.C. Mraw, *Rev. Sci. Instrum.*, 53 (1982) 228.
- 6 Y. Saito, K. Saito and T. Atake, *Thermochim. Acta*, 99 (1986) 299.

- 7 R.V. Churchill, *Operational Mathematics*, McGraw-Hill, New York, 3rd edn., 1972, Chap. 1.
- 8 B.C. Kuo, *Automatic Control System*, Prentice-Hall, Englewood Cliffs, NJ, 4th edn., 1982, p. 26.
- 9 B.C. Kuo, *Automatic Control System*, Prentice-Hall, Englewood Cliffs, NJ, 4th edn., 1982, p. 714.
- 10 B.C. Kuo, *Automatic Control System*, Prentice-Hall, Englewood Cliffs, NJ, 4th edn., 1982, Chap. 6.
- 11 S. Tanaka, *Thermochim. Acta*, 141 (1989) 181.